

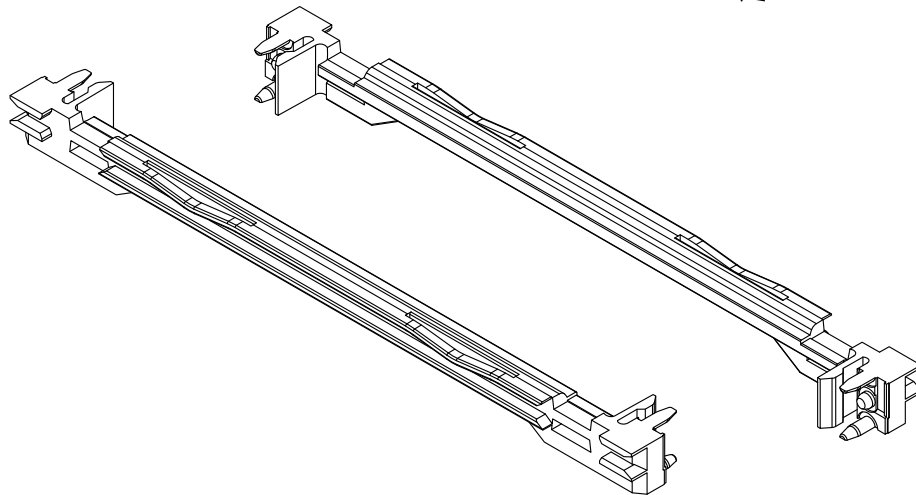

REV.	DESCRIPTION	DATE	APPROVED
B	Engineering Release.	11/19/14	J. C.

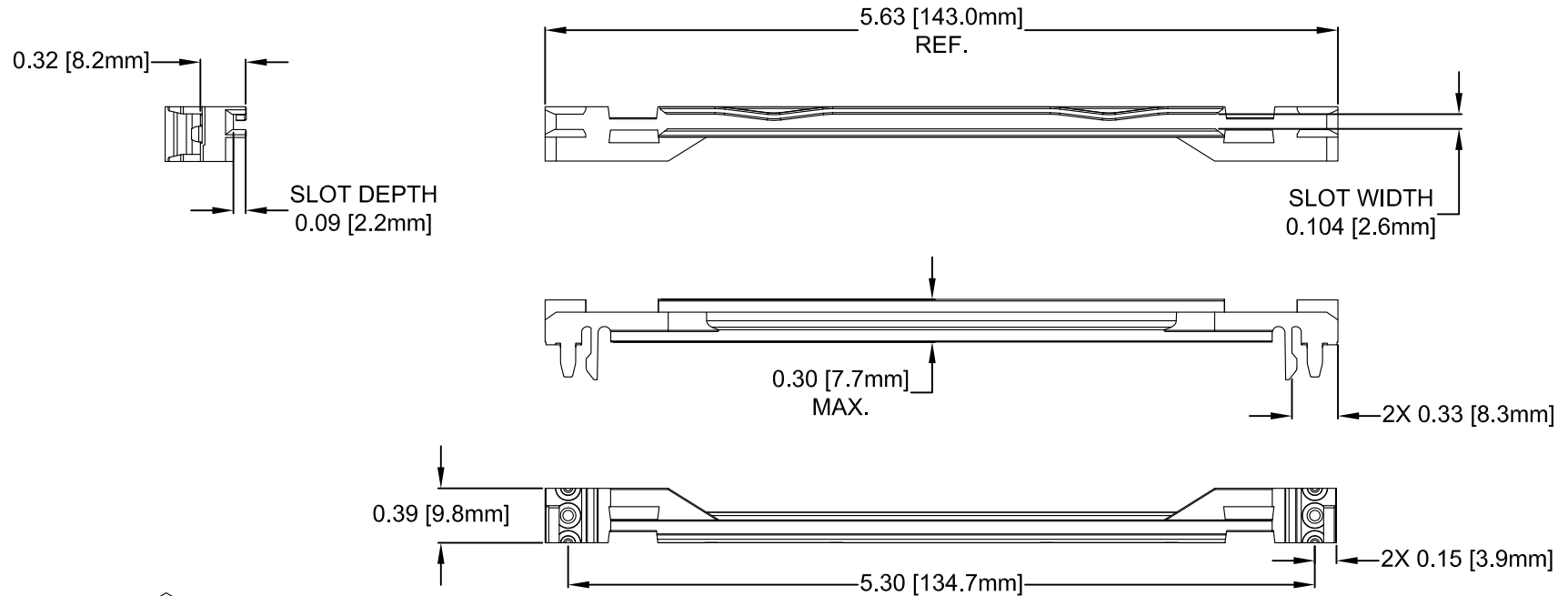

- 2. MATERIAL: POLYCARBONATE, 20% GLASS FILLED & ALUMINUM BODY
- 1. GENERAL SPECIFICATIONS: BIVAR MOLDED COMPONENT SPECIFICATION BV00-E101.

STANDARD TOLERANCE (UNLESS OTHERWISE SPECIFIED)		 BIVAR [®] 4 THOMAS, IRVINE, CA. 92618 TEL: (949) 951-8808 FAX: (949) 951-3974	
DECIMALS	ANGULAR		
.X ±.1	X° ± 1°	TITLE: VME CARD GUIDE	
.XX ±.01			
.XXX ±.005			
DESIGNED: Alex Wright	DATE: 08/21/14	PART NO: CPCI-MV160	REVISION: B
CHECKED: Brian Oliver	DATE: 08/21/14	CAGE CODE : 32559	SHEET # 1 OF 1
CAD GENERATED DOCUMENT, DO NOT MEASURE DRAWING.			