

FEATURES

Input voltage range: 2.5 V to 5.5 V

Output current range: 0 mA to 200 mA per output

Output voltage accuracy: $\pm 1\%$

Operating temperature range: -40°C to $+125^{\circ}\text{C}$

GENERAL DESCRIPTION

The ADP220/ADP221 evaluation boards are used to demonstrate the functionality of the ADP220/ADP221 series of linear regulators.

Simple device measurements such as line and load regulation, dropout, and ground current can be demonstrated with just a single voltage supply, a voltmeter, a current meter, and load resistors.

For more details about the ADP220/ADP221 linear regulator, see the ADP220/ADP221 data sheet.

EVALUATION BOARD DIGITAL PICTURE

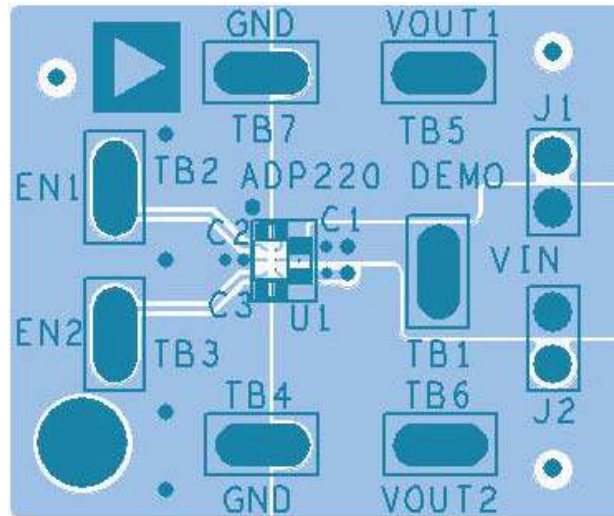

Figure 1. ADP220/ADP221 Evaluation Board

Rev. 0

Evaluation boards are only intended for device evaluation and not for production purposes. Evaluation boards are supplied "as is" and without warranties of any kind, express, implied, or statutory including, but not limited to, any implied warranty of merchantability or fitness for a particular purpose. No license is granted by implication or otherwise under any patents or other intellectual property by application or use of evaluation boards. Information furnished by Analog Devices is believed to be accurate and reliable. However, no responsibility is assumed by Analog Devices for its use, nor for any infringements of patents or other rights of third parties that may result from its use. Analog Devices reserves the right to change devices or specifications at any time without notice. Trademarks and registered trademarks are the property of their respective owners. Evaluation boards are not authorized to be used in life support devices or systems.

TABLE OF CONTENTS

Features	1	Dropout Voltage	5
General Description	1	Ground Current Measurements	6
Evaluation Board Digital Picture.....	1	Ground Current Consumption	6
Revision History	2	Printed Circuit Board Layout Considerations.....	7
Evaluation Board Hardware and Schematic	3	Ordering Information.....	8
Evaluation Board Configurations	3	Bill of Materials.....	8
Output Voltage Measurements	4	Ordering Guide	8
Line Regulation.....	5	ESD Caution.....	8
Load Regulation.....	5		

REVISION HISTORY

10/08—Revision 0: Initial Version

EVALUATION BOARD HARDWARE AND SCHEMATIC

EVALUATION BOARD CONFIGURATIONS

The ADP220/ADP221 evaluation boards are supplied with different components, depending on which version is ordered. Components common to all versions are C1, C2, C3, J1, and J2. Figure 2 shows the schematic of this evaluation board configuration.

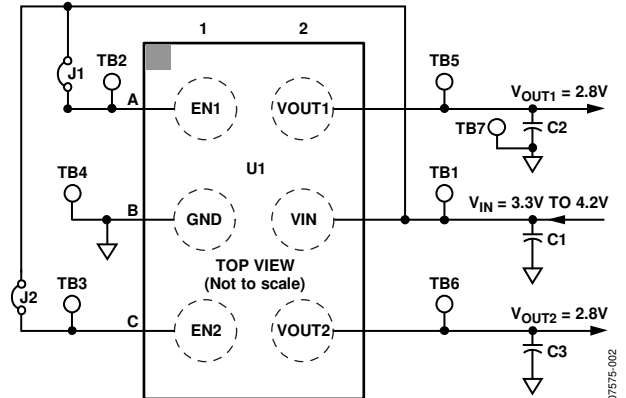

Figure 2. Evaluation Board Schematic

Table 1. Evaluation Board Hardware Components

Component	Function	Description
U1 ¹	Linear regulator	ADP220/ADP221 low dropout linear regulator.
C1	Input capacitor	1 μ F input bypass capacitor, 0402 case.
C2, C3	Output capacitors	2.2 μ F output capacitors; 0402 case. Required for stability and transient performance.
J1, J2	Jumper	These jumpers connect EN1 and EN2 to VIN for automatic startup.

¹ Component varies depending on the evaluation board type ordered.

OUTPUT VOLTAGE MEASUREMENTS

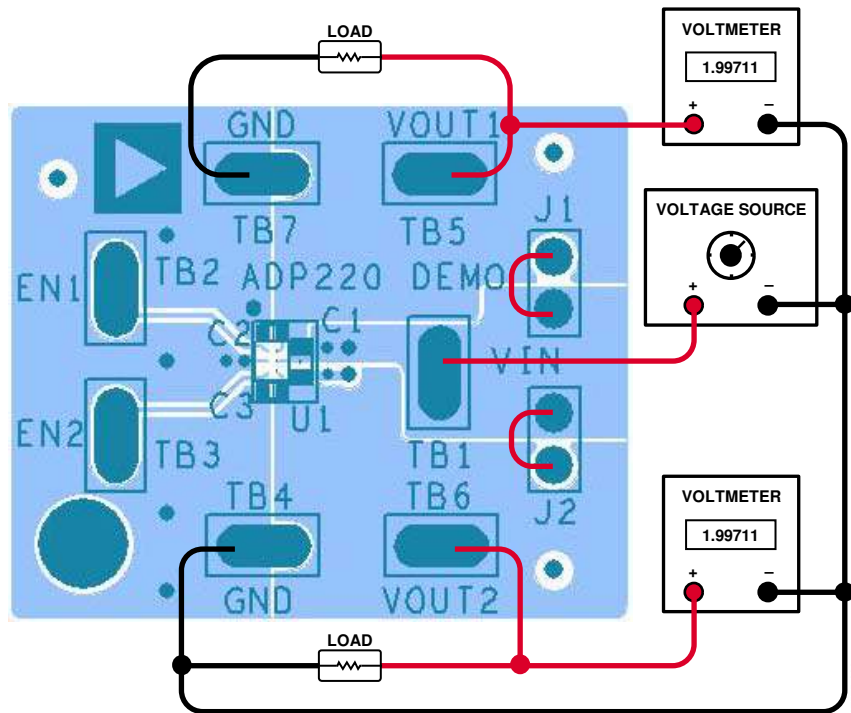

Figure 3. Output Voltage Measurement Setup

Figure 3 shows the evaluation board can be connected to a voltage source and voltmeters for basic output voltage accuracy measurements. A resistor can be used as the load for the regulator. Ensure that the resistor has a power rating adequate to handle the power expected to be dissipated across it. An electronic load can also be used as an alternative. In addition, ensure that the voltage source can supply enough current for the expected load levels.

Follow these steps to connect to a voltage source and voltmeters:

1. Connect the negative terminal (–) of the voltage source to one of the GND pads on the evaluation board.
2. Connect the positive terminal (+) of the voltage source to the VIN pad of the evaluation board.
3. Connect a load between VOUT1 or VOUT2 and one of the GND pads.
4. Connect the negative terminal (–) of the voltmeter to one of the GND pads.
5. Connect the positive terminals (+) of the voltmeters TB5 (VOUT1) or TB6 (VOUT2).

The voltage source can now be turned on. If J1 or J2 is inserted (connecting EN1 or EN2 to VIN for automatic startup), the regulator powers up.

LINE REGULATION

For line regulation measurements, the regulator’s outputs are monitored while its input is varied. For good line regulation, the outputs must change as little as possible with varying input levels. To ensure that the device is not in dropout mode during this measurement, V_{IN} must be varied between $V_{OUTNOM} + 0.5\text{ V}$ (or 2.5 V, whichever is greater) and V_{INMAX} . For example, for an ADP220/ADP221 with fixed 2.8 V output, V_{IN} needs to be varied between 3.3 V and 5.5 V. This measurement can be repeated under different load conditions. Figure 4 shows the typical line regulation performance of an ADP220/ADP221 with fixed 2.8 V output.

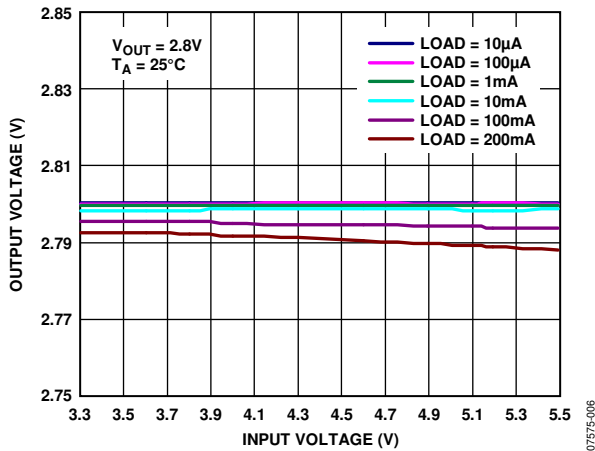

Figure 4. Output Voltage vs. Input Voltage

LOAD REGULATION

For load regulation measurements, the regulator’s outputs are monitored while the loads are varied. For good load regulation, the outputs must change as little as possible with varying loads. The input voltage must be held constant during this measurement. The load currents can be varied from 0 mA to 200 mA per output. Figure 5 shows the typical load regulation performance of a single 2.8 V output of the ADP220/ADP221 for an input voltage of 3.3 V.

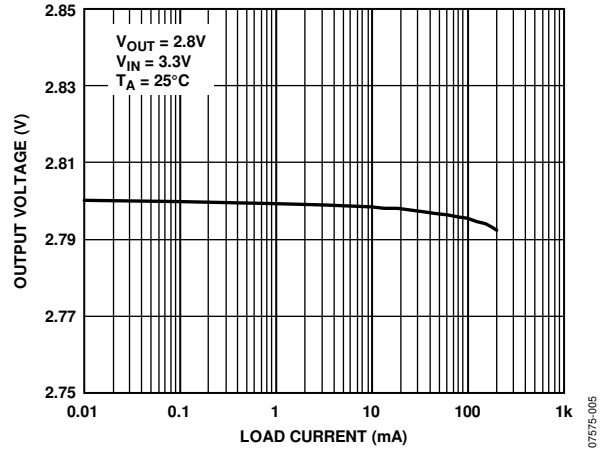

Figure 5. Output Voltage vs. Load Current

DROPOUT VOLTAGE

Dropout voltage can be measured using the configuration shown in Figure 3. Dropout voltage is defined as the input-to-output voltage differential when the input voltage is set to the nominal output voltage. This applies only for output voltages above 2.5 V. Dropout voltage increases with larger loads. For more accurate measurements, a second voltmeter can be used to monitor the input voltage across the input capacitor. The input supply voltage may need to be adjusted to account for IR drops, especially if large load currents are used. Figure 6 shows the typical curve of the dropout voltage measurement with different load currents.

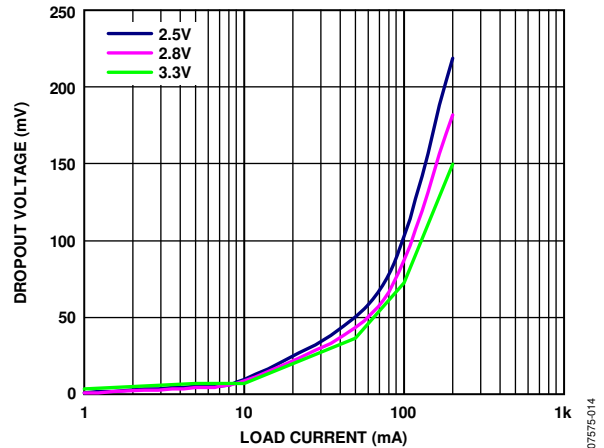

Figure 6. Dropout Voltage vs. Load Current, $V_{OUT} = 2.8\text{ V}$

GROUND CURRENT MEASUREMENTS

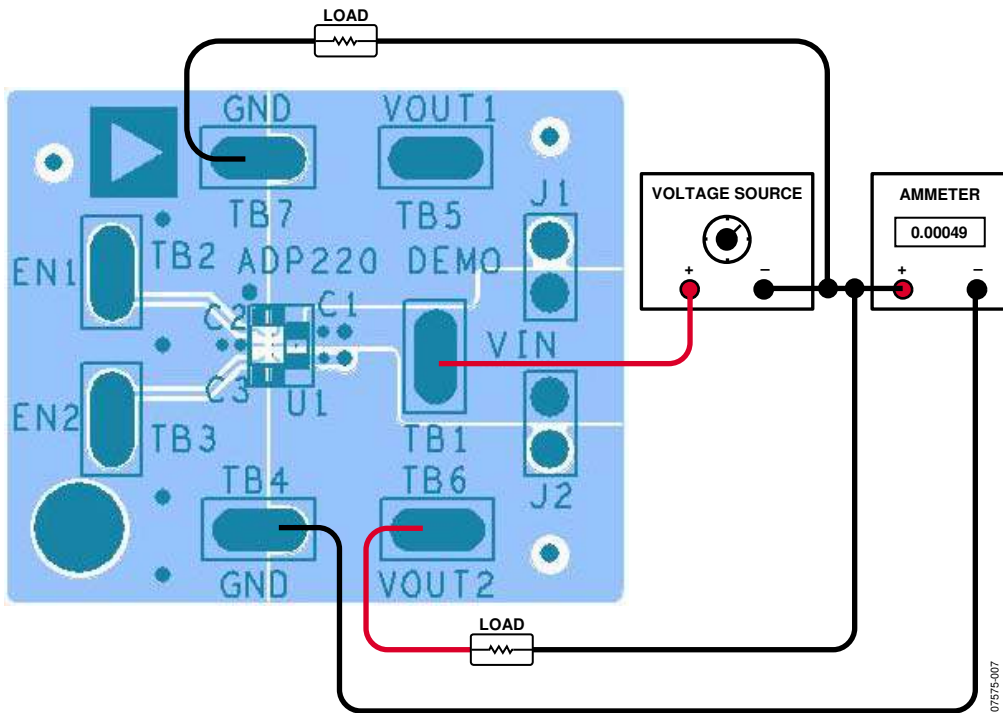

Figure 7. Ground Current Measurement

Figure 7 shows how the evaluation board can be connected to a voltage source and an ammeter for ground current measurements. A resistor can be used as the load for the regulator. Ensure that the resistor has a power rating adequate to handle the power expected to be dissipated across it. An electronic load can be used as an alternative. Ensure that the voltage source used can supply enough current for the expected load levels.

Use the following steps to connect to a voltage source and ammeter:

1. Connect the positive terminal (+) of the voltage source to the VIN pad on the evaluation board.
2. Connect the positive terminal (+) of the ammeter to one of the GND pads of the evaluation board.
3. Connect the negative terminal (-) of the ammeter to the negative (-) terminal of the voltage source.
4. Connect a load between VOUT1 and/or VOUT2 of the evaluation board and the negative (-) terminal of the voltage source.

The voltage source can now be turned on. If J1 or J2 is inserted (connecting EN1 or EN2 to VIN for automatic startup), the regulator powers up.

GROUND CURRENT CONSUMPTION

Ground current measurements can determine how much current the regulator's internal circuits are consuming while the circuits perform the regulation function. To be efficient, the regulator needs to consume as little current as possible. Typically, the regulator uses the maximum current when supplying its largest load level (200 mA per output). Figure 8 shows the typical ground current consumption for various load levels at an input voltage of 3.3 V for a single output.

When the device is disabled (EN1 and EN2 = GND), ground current drops to less than 1 μ A.

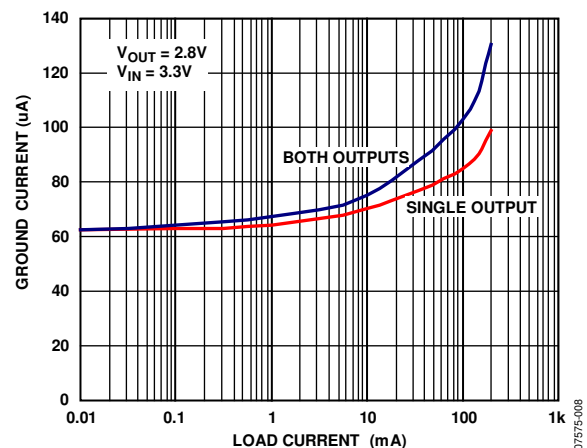

Figure 8. Ground Current vs. Load Current

PRINTED CIRCUIT BOARD LAYOUT CONSIDERATIONS

Heat dissipation from the package can be improved by increasing the amount of copper attached to the pins of the ADP220/ADP221.

Here are a few general tips when designing PCBs:

- Place the input capacitor as close as possible to the VIN and GND pins.
- Place the output capacitors as close as possible to the VOUT1, VOUT2, and GND pins.
- Use 0402 or 0603 size capacitors and resistors to achieve the smallest possible footprint solution on boards where area is limited.

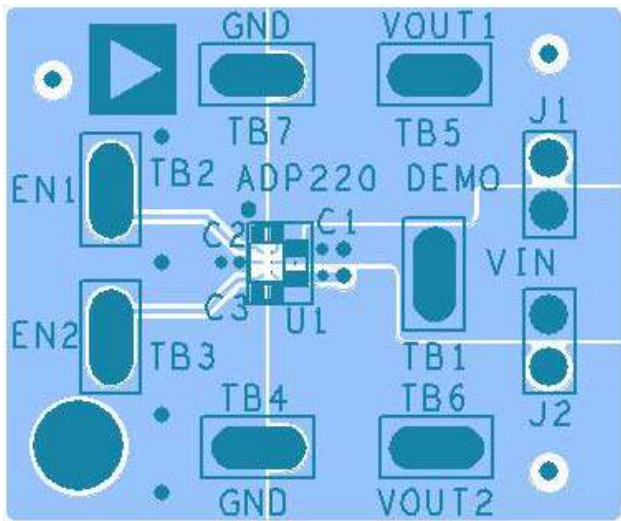

Figure 9. Typical Board Layout, Top Side

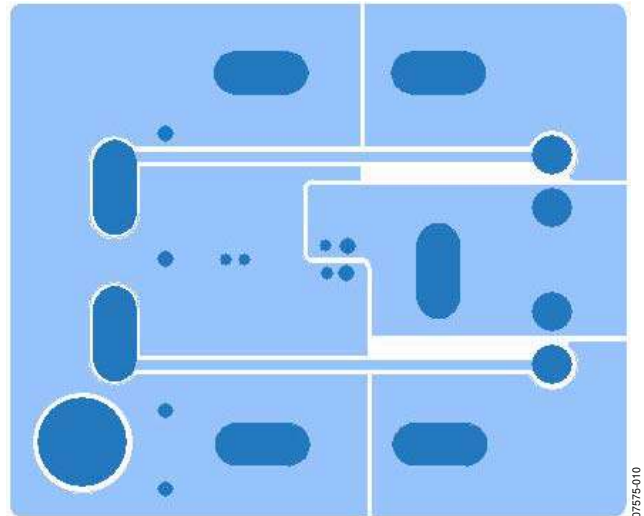

Figure 10. Typical Board Layout, Bottom Side

EVAL-ADP220/ADP221

ORDERING INFORMATION

BILL OF MATERIALS

Table 2.

Qty	Reference Designator	Description	Manufacturer/Vendor	Vendor Part No.
1	C1	Capacitor, MLCC, 1.0 μ F, 10 V, 0402, X5R	Murata or equivalent	GRM155R61A105KE15
2	C2, 3	Capacitor, MLCC, 2.2 μ F, 4 V, 0402, X5R	Murata or equivalent	GRM155R60G225ME15
2	J1, J2	Header, single, STR, 2 pins	Digi-Key Corp.	S1012E-36-ND
1	U1	IC, LDO regulator	Analog Devices, Inc.	ADP220ACBZ-2828R7 ADP221ACBZ-2828R7

ORDERING GUIDE

Model	Output Voltage (V)	Description
ADP220-2828-EVALZ ¹	2.8/2.8	2.8 V/2.8 V evaluation board
ADP221-2828-EVALZ ¹	2.8/2.8	2.8 V/2.8 V with output discharge evaluation board

¹ Z = RoHS Compliant Part.

ESD CAUTION



ESD (electrostatic discharge) sensitive device. Charged devices and circuit boards can discharge without detection. Although this product features patented or proprietary protection circuitry, damage may occur on devices subjected to high energy ESD. Therefore, proper ESD precautions should be taken to avoid performance degradation or loss of functionality.