

**STRAIGHT MALE CONNECTOR SMOOTHBORE**  
**SOLDER CABLE .085**

**R201.223.700**

Series : SMPM

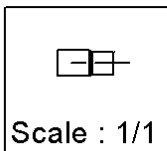
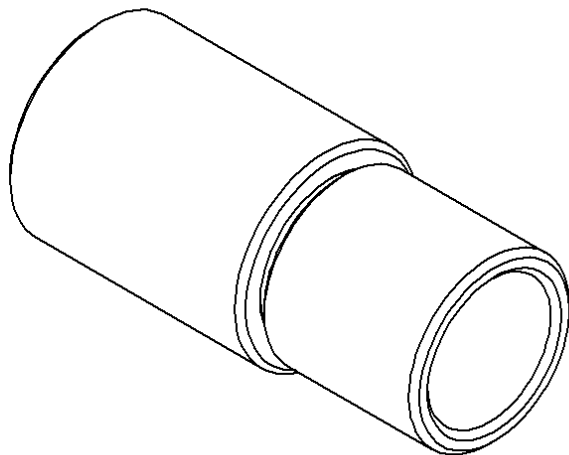
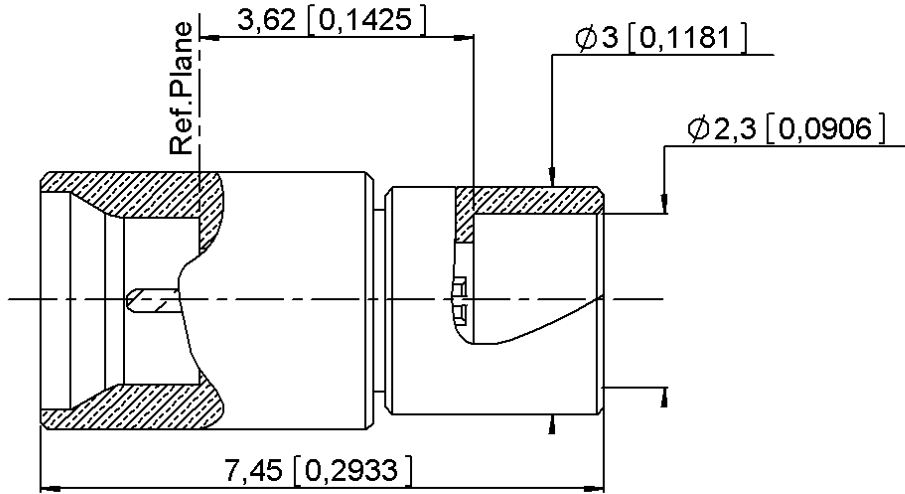

All dimensions are in mm.

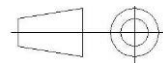

COMPONENTS	MATERIALS	PLATING (µm)
BODY	BERYLLIUM COPPER	GOLD 0.5 OVER NICKEL 2
CENTER CONTACT	BERYLLIUM COPPER	GOLD 1.3 OVER NICKEL 2
OUTER CONTACT	-	-
INSULATOR	PEEK	-
GASKET	-	-
OTHERS PARTS	BRASS	GOLD 0.5 OVER NICKEL 2
-	-	-
-	-	-

Issue : 05-01-16A A

In the effort to improve our products, we reserve the right to make changes judged to be necessary.



**STRAIGHT MALE CONNECTOR SMOOTHBORE**

**R201.223.700**

**SOLDER CABLE .085**

Series : **SMPM**

**PACKAGING**

Standard	Unit	Other
<b>100</b>	<b>'W' option</b>	<b>Contact us</b>

**SPECIFICATION**

**ELECTRICAL CHARACTERISTICS**

Impedance	<b>50</b>	$\Omega$
Frequency	<b>0-40</b>	GHz
VSWR	<b>*1.35 + 0,0000</b>	x F(GHz) Maxi
Insertion loss	<b>0.12</b>	$\sqrt{F}$ (GHz) dB Maxi
RF leakage	- ( <b>NA</b> )	- F(GHz)) dB Maxi
Voltage rating	<b>335</b>	Veff Maxi
Dielectric withstanding voltage	<b>500</b>	Veff mini
Insulation resistance	<b>5000</b>	M $\Omega$ mini

**CABLE ASSEMBLY**

Stripping	a	b	c	d	e	f
mm	1,30	0,00	0,00	0,00	0,00	0,00

Assembly instruction :

Recommended cable(s)  
RG 405

Characteristics indicated on this data sheet are those that can be achieved with the highest performance cable. Intrinsic limitations of the cable may diminish the performance of the assembly

Cable retention

- pull off **130** N mini
- torque **NA** N.cm

**MECHANICAL CHARACTERISTICS**

Center contact retention		
Axial force – Mating end	<b>6.7</b>	N mini
Axial force – Opposite end	<b>6.7</b>	N mini
Torque	<b>NA</b>	N.cm mini

Recommended torque		
Mating	<b>NA</b>	N.cm
Panel nut	<b>NA</b>	N.cm
Clamp nut	<b>NA</b>	N.cm
A/F clamp nut	<b>0,0000</b>	mm

Mating life	<b>500</b>	Cycles mini
Weight	<b>0,3300</b>	g

**TOOLING**

Part Number	Description	Hexagon
R282740020	SOLDERING MOUNTING	
R282743130	POSITIONER FOR SOLDERING SMPM	

**OTHER CHARACTERISTICS**

\*VSWR 1.15 TO 26.5 GHz

**ENVIRONMENTAL**

Operating temperature	<b>-40/+125</b>	$^{\circ}$ C
Hermetic seal	<b>NA</b>	Atm.cm3/s
Panel leakage	<b>NA</b>	

Issue : **05-01-16A A**

In the effort to improve our products, we reserve the right to make changes judged to be necessary.



**STRAIGHT MALE CONNECTOR SMOOTHBORE**  
**SOLDER CABLE .085**

**R201.223.700**

Series : SMPM

**COMPONENT**

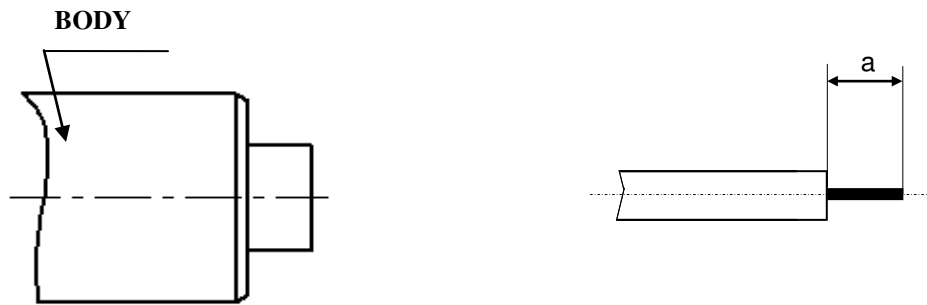

**We recommend a cable thermal preconditioning before assembly**

1

- Strip the cable.
- Trim the cable inner conductor.
- Clean the cable

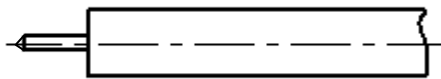

2

- Slide body into the positioner.
- Introduce the cable into the connector body until it stops.
- Place the sub assembly into the assembly and tighten it .
- Solder the body onto the cable.
- After cooling remove cable assembly from the jig.

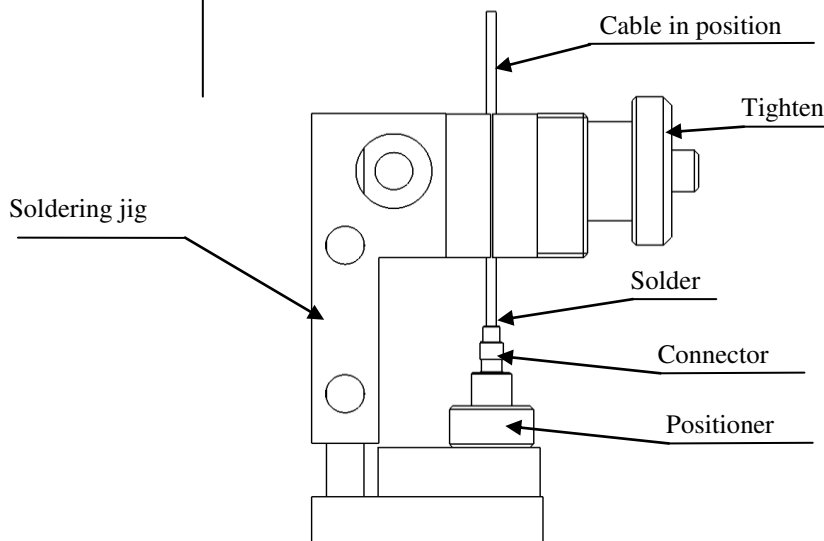

Issue : 05-01-16A A

In the effort to improve our products, we reserve the right to make changes judged to be necessary.

