

PRODUCT CODE:- **ENP-LD5-30** CATEGORY:- **NEMA TWIST LOCK PLUG**

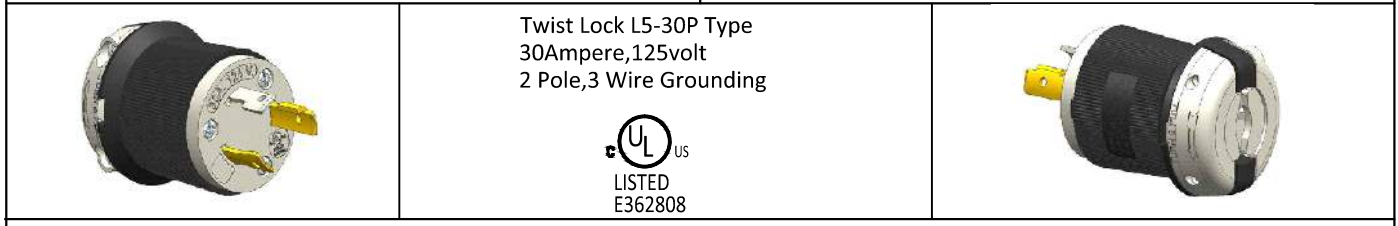

Twist Lock L5-30P Type
30Ampere,125volt
2 Pole,3 Wire Grounding



BASIC DIMENSIONS:-

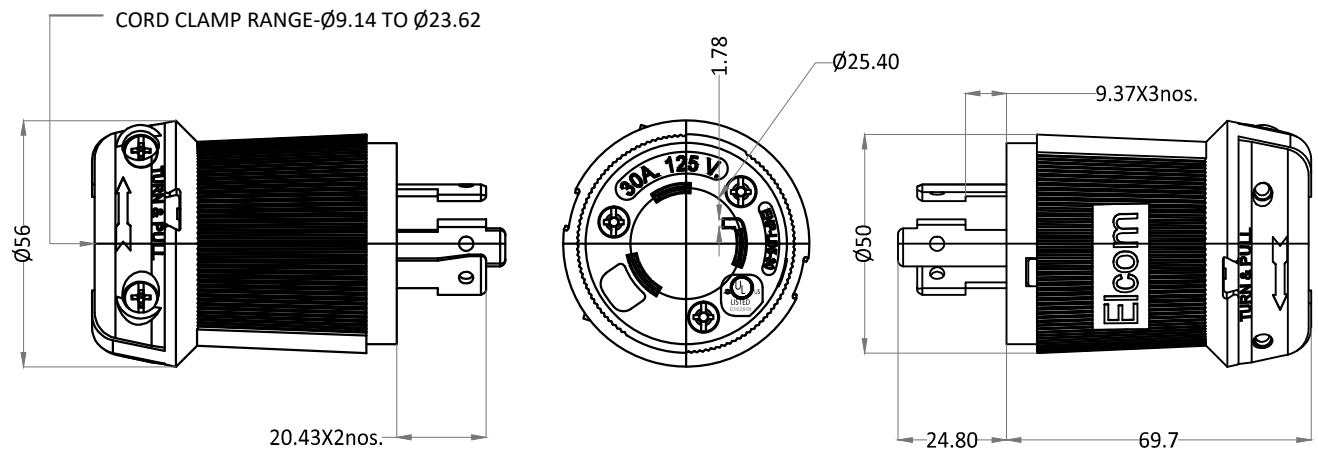

SPECIFICATION TABLE:-

SR.NO.	PARAMETER		SPECIFICATION
1	Connector Type		Twist lock L5-30P type
2	V/A Rating		125Vac, 30A
3	Insulation Resistance At 500 V DC		100 Mohms min.
4	H.V.Break Down Test (For 1-Minute)		2 KVAC
5	Terminals		Screw-type 10 AWG
6	Permissible Temp.	(a) With/Without Load	0°C TO 75°C
7	Material	(a) Body	Nylon, Black
		(b) Cord Clamp	Nylon, Natural (White) Tightening Torque : 18-21 Kg-cm.
		(c) Contact Holder	Nylon, Natural (White)
		(d) Retainer	PolyCarbonate, Clear
		(e) Contact Blades	Copper Alloy, Nickel plated/Unplated
		(f) Terminal screws	Brass Tightening Torque : 12 Kg-cm min.
8	Reference Standard		UL-498, UL-486E, NEMA WD 6 CAN/CSA C22.2 No.0-M91, CSA C22.2 No.42-99
9	Approvals		File no.E362808 (UL LISTED)
10	Flammability		UL 94, V-0

APP	12.04.14	GJG	Plot E-4, Kagal Five Star MIDC, Kagal, Kolhapur, MH - 416236, India Elcom International Pvt. Ltd. www.elcom-in.com												
CHK	12.04.14	KAK													
DRN	12.04.14														
REV	IS	WAS	DATE	SIGN	APP.	BY	DATE	SIGN							
UNSP.TOLERANCE		DIMNS. IN	WT(Gm)	SCALE:-	PROJECTION	SHEET	DRAWING NUMBER								
OVER	- 1 10	mm	Max.	NTS.		1 OF 1	P	E	N	P	2	5	3	0	REVISION
UP TO	1 10 -	Moulding, plating details as per Bill of Material													0
±	0.2 0.3 0.5	Unspecified colour is Black, GF:Glass filled.													

F:ENG-08.00

Note: Technical specifications are subject to change without prior notice

Copyright © 2019 by Elcom International Pvt.Ltd, India. All rights reserved