

**RECOMMENDED PCB LAYOUT: COMPONENT SIDE**

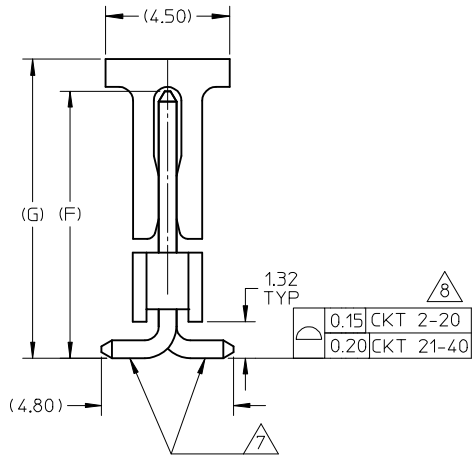

**NOTES:**

1. MATERIAL:
  - HSG: NYLON, GLASS-FILLED, UL94V-0, COLOR: BLACK
  - CAP: NYLON, GLASS-FILLED, UL94V-0, COLOR: BLACK
  - PIN: 0.64MM SQ, COPPER ALLOY
2. PLATING TYPE:
  - (1) GOLD FLASH OVER  
1.25µm MIN. NICKEL OVERALL.
  - (2) GOLD FLASH ON CONTACT AND  
2.50µm MIN. TIN ON SOLDER TAIL OVER  
1.25µm MIN. NICKEL OVERALL.
  - (4) 0.38µm MIN. GOLD PLATE ON CONTACT AND  
2.00µm MIN. TIN ON SOLDER TAIL OVER  
1.25µm MIN. NICKEL OVERALL.
  - (5) 0.75µm MIN. GOLD PLATE ON CONTACT AND  
2.00µm MIN. TIN ON SOLDER TAIL OVER  
1.25µm MIN. NICKEL OVERALL.
  - (6) 2.50µm MIN. TIN OVERALL  
1.25µm MIN. NICKEL OVERALL
3. PRODUCT SPECIFICATION: PS-87920-019
4. PACKAGING TYPE: SEE TABLE
5. PACKAGING SPEC:
  - TUBE WITH CAP VERSION: PK-89990-558
  - TUBE W/O CAP VERSION: PK-89990-545
  - EMBOSS TAPE WITH CAP: PK-89990-486
6. WAFER TO BE FLAT WITHIN 0.003 mm/mm
7. BEND DEPRESSION IS ACCEPTED SO LONG AS IT DOES NOT AFFECT THE OVERALL COPLANARITY OF TAIL
8. COPLANARITY IS TO BE MEASURED BY RESTING THE SOLDER TAIL ON A FLAT SURFACE
9. IRREGULAR CIRCUIT CUTOFF WITHIN BREAKAWAY SECTION IS PERMISSIBLE. CUTTING OR CHIPPING OF THE MAIN BODY IS NOT ACCEPTABLE
10. CAP LOCATION IS CENTERED ALONG THE MATING ENDS AS SHOWN. TOP SURFACE OF CAP TO BE FLAT FOR THE PURPOSE OF PICK & PLACE BY VACUUM SUCTION NOZZLE
11. RECOMMENDED PCB THICKNESS IS 1.60mm±0.10
12. THE ABOVE CKT 6 IS FOR ILLUSTRATION PURPOSE ONLY
13. TUBE LENGTH AS PER STANDARD 560mm

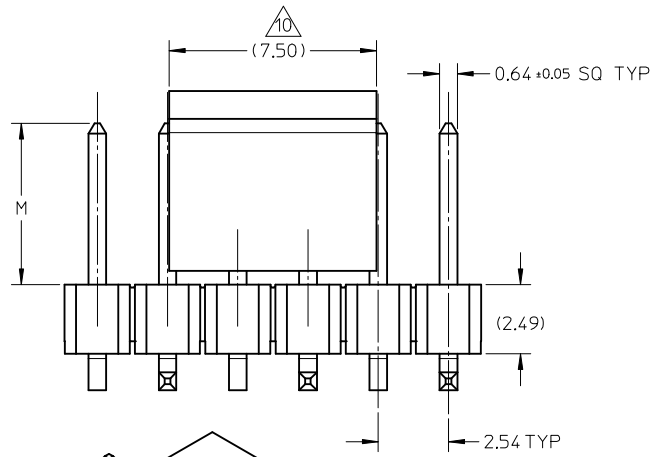
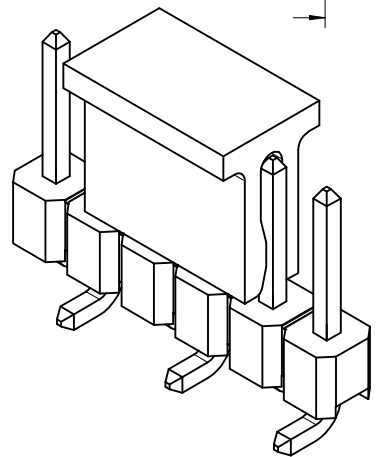

SHT2.+87898-0315 EC NO: S2014-0976 DRWN:ATSEE 2014/04/14 CHKDF:ANNYWONG 2014/04/14 APPR:LBLEE 2014/09/11	REV DESCRIPTION B12	QUALITY SYMBOLS	GENERAL TOLERANCES (UNLESS SPECIFIED)		DIMENSION STYLE		SCALE	DESIGN UNITS	THIRD ANGLE PROJECTION		
		$\nabla_{\sqrt{R}}=0$ $\nabla_{\sqrt{R}}=0$ $\nabla_{\sqrt{R}}=0$	mm	INCH	MM ONLY	NTS	METRIC	DRAWN BY: YLQIAO DATE: 2005/03/14 CHECKED BY: PTLIM DATE: 2005/03/29 APPROVED BY: MLONG DATE: 2010/10/04		TITLE: CUSTOM HEADER 2.54MM PITCH SINGLE ROW SINGLE WAFER SMT HEADER	
		4 PLACES ± --- ± ---	3 PLACES ± --- ± ---	2 PLACES ± 0.2 ± ---	1 PLACE ± --- ± ---	ANGULAR ± 3 °		MATERIAL NO. SEE TABLE		DOCUMENT NO. SD-87898-001	
		DRAFT WHERE APPLICABLE MUST REMAIN WITHIN DIMENSIONS			SIZE: A3	THIS DRAWING CONTAINS INFORMATION THAT IS PROPRIETARY TO MOLEX INCORPORATED AND SHOULD NOT BE USED WITHOUT WRITTEN PERMISSION					

10 9 8 7 6 5 4 3 2 1

PACKAGING OPTION PART NO.						CKT SIZE	VOID POSITION	PLATING TYPE	DIMENSION				
TRAY WITHOUT CAP	TRAY WITH CAP	TUBE WITHOUT CAP	TUBE WITH CAP	TAPE & REEL WITHOUT CAP	TAPE & REEL WITH CAP				A	B	G	F	M
87898-0204	-----	-----	-----	-----	87898-0214	2	----	4	5.08	2.54	10.81	9.65	5.84
87898-0207	-----	-----	-----	-----	-----	2	----	5	5.08	2.54	10.81	9.65	5.84
-----	-----	-----	87898-0208	-----	87898-0209	2	----	6	5.08	2.54	10.81	9.65	5.84
87898-0301	-----	-----	-----	-----	-----	3	----	1	7.62	5.08	10.81	9.65	5.84
87898-0302	-----	-----	-----	-----	-----	3	----	2	7.62	5.08	10.81	9.65	5.84
87898-0304	-----	-----	-----	-----	87898-0314	3	----	4	7.62	5.08	10.81	9.65	5.84
87898-0305	-----	-----	-----	-----	87898-0315	3	----	5	7.62	5.08	10.81	9.65	5.84
87898-0306	-----	-----	-----	-----	87898-0316	3	----	6	7.62	5.08	10.81	9.65	5.84

D  
C  
B

SHT2.+87898-0315 EC NO: S2014-0976 DRW:ATSEE 2014/04/14 CHKD:FANNYWONG 2014/04/14 APPR:LBLEE 2014/09/11	B12	DESCRIPTION REV	QUALITY SYMBOLS	GENERAL TOLERANCES (UNLESS SPECIFIED)	DIMENSION STYLE	SCALE	DESIGN UNITS	THIRD ANGLE PROJECTION	TITLE			
			$\nabla_A = 0$ $\nabla_C = 0$ $\nabla_P = 0$	mm    INCH 4 PLACES ± --- ± --- 3 PLACES ± --- ± --- 2 PLACES ± 0.2 ± --- 1 PLACE ± --- ± --- ANGULAR ± 3 °	MM ONLY	NTS	METRIC	DRAWN BY: YLQIAO    DATE: 2005/03/14 CHECKED BY: PTLIM    DATE: 2005/03/29 APPROVED BY: MLONG    DATE: 2010/10/04	CUSTOM HEADER 2.54MM PITCH SINGLE ROW SINGLE WAFER SMT HEADER			
			DRAFT WHERE APPLICABLE MUST REMAIN WITHIN DIMENSIONS			SEE TABLE	MOLEX INCORPORATED DOCUMENT NO. SD-87898-001		SHEET NO. 2 OF 20			
						THIS DRAWING CONTAINS INFORMATION THAT IS PROPRIETARY TO MOLEX INCORPORATED AND SHOULD NOT BE USED WITHOUT WRITTEN PERMISSION						

9 8 7 6 5 4 3 2 1

10 9 8 7 6 5 4 3 2 1

PACKAGING OPTION PART NO.						CKT SIZE	VOID POSITION	PLATING TYPE	DIMENSION				
TRAY WITHOUT CAP	TRAY WITH CAP	TUBE WITHOUT CAP	TUBE WITH CAP	TAPE & REEL WITHOUT CAP	TAPE & REEL WITH CAP				A	B	G	F	M
-----	-----	87898-0421	87898-0431	-----	87898-0451	4	-----	1	10.16	7.62	10.81	9.65	5.84
-----	-----	87898-0422	87898-0432	-----	87898-0452	4	-----	2	10.16	7.62	10.81	9.65	5.84
-----	-----	87898-0424	87898-0434	-----	87898-0454	4	-----	4	10.16	7.62	10.81	9.65	5.84
-----	-----	87898-0425	87898-0435	-----	87898-0455	4	-----	5	10.16	7.62	10.81	9.65	5.84
-----	-----	87898-0426	87898-0436	-----	87898-0456	4	-----	6	10.16	7.62	10.81	9.65	5.84
-----	-----	87898-0521	87898-0531	-----	87898-0551	5	-----	1	12.70	10.16	10.81	9.65	5.84
-----	-----	87898-0522	87898-0532	-----	87898-0552	5	-----	2	12.70	10.16	10.81	9.65	5.84
-----	-----	87898-0524	87898-0534	-----	87898-0554	5	-----	4	12.70	10.16	10.81	9.65	5.84
-----	-----	87898-0525	87898-0535	-----	87898-0555	5	-----	5	12.70	10.16	10.81	9.65	5.84
-----	-----	87898-0526	87898-0536	-----	87898-0556	5	-----	6	12.70	10.16	10.81	9.65	5.84
-----	-----	87898-0621	87898-0631	-----	87898-0651	6	-----	1	15.24	12.70	10.81	9.65	5.84
-----	-----	87898-0622	87898-0632	-----	87898-0652	6	-----	2	15.24	12.70	10.81	9.65	5.84
-----	-----	87898-0624	87898-0634	-----	87898-0654	6	-----	4	15.24	12.70	10.81	9.65	5.84
-----	-----	87898-0625	87898-0635	-----	87898-0655	6	-----	5	15.24	12.70	10.81	9.65	5.84
-----	-----	87898-0626	87898-0636	-----	87898-0656	6	-----	6	15.24	12.70	10.81	9.65	5.84
87898-0607	-----	-----	-----	-----	87898-0657	6	-----	6	15.24	12.70	16.47	15.31	11.50

B

SHT2.+87898-0315 EC NO: S2014-0976 DRW:ATSEE 2014/04/14 CHKD:FANNYWONG 2014/04/14 APPR:LBLEE 2014/09/11	QUALITY SYMBOLS F=0 F=0 F=0	GENERAL TOLERANCES (UNLESS SPECIFIED)		DIMENSION STYLE MM ONLY		SCALE NTS	DESIGN UNITS METRIC	THIRD ANGLE PROJECTION		
				DRAWN BY YLQIAO	DATE 2005/03/14		TITLE CUSTOM HEADER 2.54MM PITCH SINGLE ROW SINGLE WAFER SMT HEADER			
				CHECKED BY PTLIM	DATE 2005/03/29		MOLEX INCORPORATED			
				APPROVED BY MLONG	DATE 2010/10/04		MATERIAL NO. SEE TABLE		DOCUMENT NO. SD-87898-001	
		DRAFT WHERE APPLICABLE MUST REMAIN WITHIN DIMENSIONS		THIS DRAWING CONTAINS INFORMATION THAT IS PROPRIETARY TO MOLEX INCORPORATED AND SHOULD NOT BE USED WITHOUT WRITTEN PERMISSION						

A

PACKAGING OPTION PART NO.						CKT SIZE	VOID POSITION	PLATING TYPE	DIMENSION				
TRAY WITHOUT CAP	TRAY WITH CAP	TUBE WITHOUT CAP	TUBE WITH CAP	TAPE & REEL WITHOUT CAP	TAPE & REEL WITH CAP				A	B	G	F	M
-----	-----	87898-0721	87898-0731	-----	87898-0751	7	-----	1	17.78	15.24	10.81	9.65	5.84
-----	-----	87898-0722	87898-0732	-----	87898-0752	7	-----	2	17.78	15.24	10.81	9.65	5.84
-----	-----	87898-0724	87898-0734	-----	87898-0754	7	-----	4	17.78	15.24	10.81	9.65	5.84
-----	-----	87898-0725	87898-0735	-----	87898-0755	7	-----	5	17.78	15.24	10.81	9.65	5.84
-----	-----	87898-0726	87898-0736	-----	87898-0756	7	-----	6	17.78	15.24	10.81	9.65	5.84
-----	-----	87898-0821	87898-0831	-----	87898-0851	8	-----	1	20.32	17.78	10.81	9.65	5.84
-----	-----	87898-0822	87898-0832	-----	87898-0852	8	-----	2	20.32	17.78	10.81	9.65	5.84
-----	-----	87898-0824	87898-0834	-----	87898-0854	8	-----	4	20.32	17.78	10.81	9.65	5.84
-----	-----	87898-0825	87898-0835	-----	87898-0855	8	-----	5	20.32	17.78	10.81	9.65	5.84
-----	-----	87898-0826	87898-0836	-----	87898-0856	8	-----	6	20.32	17.78	10.81	9.65	5.84
-----	-----	87898-0921	87898-0931	-----	87898-0951	9	-----	1	22.86	20.32	10.81	9.65	5.84
-----	-----	87898-0922	87898-0932	-----	87898-0952	9	-----	2	22.86	20.32	10.81	9.65	5.84
-----	-----	87898-0924	87898-0934	-----	87898-0954	9	-----	4	22.86	20.32	10.81	9.65	5.84
-----	-----	87898-0925	87898-0935	-----	87898-0955	9	-----	5	22.86	20.32	10.81	9.65	5.84
-----	-----	87898-0926	87898-0936	-----	87898-0956	9	-----	6	22.86	20.32	10.81	9.65	5.84

<b>SHT2+87898-0315</b> EC NO: S2014-0976 DRWN:ATSEE 2014/04/14 CHKD:FANNY WONG 2014/04/14 APPR: LBLEE 2014/09/11	REV DESCRIPTION B12	QUALITY SYMBOLS	GENERAL TOLERANCES (UNLESS SPECIFIED)	DIMENSION STYLE	SCALE	DESIGN UNITS	THIRD ANGLE PROJECTION																							
		$\nabla_A = 0$ $\nabla_C = 0$ $\nabla_P = 0$	<table border="1"> <tr><th colspan="2">mm</th><th>INCH</th></tr> <tr><td>4 PLACES</td><td>± ---</td><td>± ---</td></tr> <tr><td>3 PLACES</td><td>± ---</td><td>± ---</td></tr> <tr><td>2 PLACES</td><td>± 0.2</td><td>± ---</td></tr> <tr><td>1 PLACE</td><td>± ---</td><td>± ---</td></tr> </table>	mm		INCH	4 PLACES	± ---	± ---	3 PLACES	± ---	± ---	2 PLACES	± 0.2	± ---	1 PLACE	± ---	± ---	MM ONLY	NTS	METRIC									
		mm		INCH																										
		4 PLACES	± ---	± ---																										
3 PLACES	± ---	± ---																												
2 PLACES	± 0.2	± ---																												
1 PLACE	± ---	± ---																												
	<table border="1"> <tr><td>4 PLACES</td><td>± ---</td><td>± ---</td></tr> <tr><td>3 PLACES</td><td>± ---</td><td>± ---</td></tr> <tr><td>2 PLACES</td><td>± 0.2</td><td>± ---</td></tr> <tr><td>1 PLACE</td><td>± ---</td><td>± ---</td></tr> </table>	4 PLACES	± ---	± ---	3 PLACES	± ---	± ---	2 PLACES	± 0.2	± ---	1 PLACE	± ---	± ---	<table border="1"> <tr><td>DRAWN BY</td><td>DATE</td></tr> <tr><td>YLOIAO</td><td>2005/03/14</td></tr> <tr><td>CHECKED BY</td><td>DATE</td></tr> <tr><td>PTLIM</td><td>2005/03/29</td></tr> <tr><td>APPROVED BY</td><td>DATE</td></tr> <tr><td>MLONG</td><td>2010/10/04</td></tr> </table>	DRAWN BY	DATE	YLOIAO	2005/03/14	CHECKED BY	DATE	PTLIM	2005/03/29	APPROVED BY	DATE	MLONG	2010/10/04	TITLE			CUSTOM HEADER 2.54MM PITCH SINGLE ROW SINGLE WAFER SMT HEADER
4 PLACES	± ---	± ---																												
3 PLACES	± ---	± ---																												
2 PLACES	± 0.2	± ---																												
1 PLACE	± ---	± ---																												
DRAWN BY	DATE																													
YLOIAO	2005/03/14																													
CHECKED BY	DATE																													
PTLIM	2005/03/29																													
APPROVED BY	DATE																													
MLONG	2010/10/04																													
		ANGULAR ± 3 °  DRAFT WHERE APPLICABLE MUST REMAIN WITHIN DIMENSIONS	SEE TABLE	MOLEX INCORPORATED	DOCUMENT NO. SD-87898-001	SHEET NO. 4 OF 20																								

PACKAGING OPTION PART NO.										DIMENSION				
TRAY WITHOUT CAP	TRAY WITH CAP	TUBE WITHOUT CAP	TUBE WITH CAP	TAPE & REEL WITHOUT CAP	TAPE & REEL WITH CAP	CKT SIZE	VOID POSITION	PLATING TYPE	A	B	G	F	M	
-----	-----	87898-1021	87898-1031	-----	87898-1051	10	-----	1	25.40	22.86	10.81	9.65	5.84	
-----	-----	87898-1022	87898-1032	-----	87898-1052	10	-----	2	25.40	22.86	10.81	9.65	5.84	
-----	-----	87898-1024	87898-1034	-----	87898-1054	10	-----	4	25.40	22.86	10.81	9.65	5.84	
-----	-----	87898-1025	87898-1035	-----	87898-1055	10	-----	5	25.40	22.86	10.81	9.65	5.84	
-----	-----	87898-1026	87898-1036	-----	87898-1056	10	-----	6	25.40	22.86	10.81	9.65	5.84	
-----	-----	87898-1121	87898-1131	-----	87898-1151	11	-----	1	27.94	25.40	10.81	9.65	5.84	
-----	-----	87898-1122	87898-1132	-----	87898-1152	11	-----	2	27.94	25.40	10.81	9.65	5.84	
-----	-----	87898-1124	87898-1134	-----	87898-1154	11	-----	4	27.94	25.40	10.81	9.65	5.84	
-----	-----	87898-1125	87898-1135	-----	87898-1155	11	-----	5	27.94	25.40	10.81	9.65	5.84	
-----	-----	87898-1126	87898-1136	-----	87898-1156	11	-----	6	27.94	25.40	10.81	9.65	5.84	
-----	-----	87898-1221	87898-1231	-----	87898-1251	12	-----	1	30.48	27.94	10.81	9.65	5.84	
-----	-----	87898-1222	87898-1232	-----	87898-1252	12	-----	2	30.48	27.94	10.81	9.65	5.84	
-----	-----	87898-1224	87898-1234	-----	87898-1254	12	-----	4	30.48	27.94	10.81	9.65	5.84	
-----	-----	87898-1225	87898-1235	-----	87898-1255	12	-----	5	30.48	27.94	10.81	9.65	5.84	
-----	-----	87898-1226	87898-1236	-----	87898-1256	12	-----	6	30.48	27.94	10.81	9.65	5.84	

<b>SHT 2,+87898-0315</b> IEC NO: S2014-0976 DRWN:ATSEE 2014/04/14 CH'KD:FANNYWONG 2014/04/14 APPR:LBLEE 2014/09/11	QUALITY SYMBOLS $\nabla_A = 0$ $\nabla_B = 0$ $\nabla_C = 0$	GENERAL TOLERANCES (UNLESS SPECIFIED)		DIMENSION STYLE <b>MM ONLY</b>		SCALE NTS	DESIGN UNITS METRIC	THIRD ANGLE PROJECTION			
				mm	INCH	DRAWN BY YLQIAO	DATE 2005/03/14	TITLE <b>CUSTOM HEADER 2.54MM PITCH SINGLE ROW SINGLE WAFER SMT HEADER</b>			
				4 PLACES $\pm$ --- $\pm$ ---	3 PLACES $\pm$ --- $\pm$ ---	CHECKED BY PTLIM	DATE 2005/03/29				
				2 PLACES $\pm$ 0.2 $\pm$ ---	1 PLACE $\pm$ --- $\pm$ ---	APPROVED BY MLONG	DATE 2010/10/04	MOLEX MOLEX INCORPORATED			
		ANGULAR $\pm$ 3 °		MATERIAL NO. <b>SEE TABLE</b>		DOCUMENT NO. SD-87898-001		SHEET NO. 5 OF 20			
		DRAFT WHERE APPLICABLE MUST REMAIN WITHIN DIMENSIONS				THIS DRAWING CONTAINS INFORMATION THAT IS PROPRIETARY TO MOLEX INCORPORATED AND SHOULD NOT BE USED WITHOUT WRITTEN PERMISSION					

PACKAGING OPTION PART NO.						CKT SIZE	VOID POSITION	PLATING TYPE	DIMENSION				
TRAY WITHOUT CAP	TRAY WITH CAP	TUBE WITHOUT CAP	TUBE WITH CAP	TAPE & REEL WITHOUT CAP	TAPE & REEL WITH CAP				A	B	G	F	M
-----	-----	87898-1321	87898-1331	-----	87898-1351	13	-----	1	33.02	30.48	10.81	9.65	5.84
-----	-----	87898-1322	87898-1332	-----	87898-1352	13	-----	2	33.02	30.48	10.81	9.65	5.84
-----	-----	87898-1324	87898-1334	-----	87898-1354	13	-----	4	33.02	30.48	10.81	9.65	5.84
-----	-----	87898-1325	87898-1335	-----	87898-1355	13	-----	5	33.02	30.48	10.81	9.65	5.84
-----	-----	87898-1326	87898-1336	-----	87898-1356	13	-----	6	33.02	30.48	10.81	9.65	5.84
-----	-----	87898-1421	87898-1431	-----	87898-1451	14	-----	1	35.56	33.02	10.81	9.65	5.84
-----	-----	87898-1422	87898-1432	-----	87898-1452	14	-----	2	35.56	33.02	10.81	9.65	5.84
-----	-----	87898-1424	87898-1434	-----	87898-1454	14	-----	4	35.56	33.02	10.81	9.65	5.84
-----	-----	87898-1425	87898-1435	-----	87898-1455	14	-----	5	35.56	33.02	10.81	9.65	5.84
-----	-----	87898-1426	87898-1436	-----	87898-1456	14	-----	6	35.56	33.02	10.81	9.65	5.84
-----	-----	87898-1521	87898-1531	-----	87898-1551	15	-----	1	38.10	35.56	10.81	9.65	5.84
-----	-----	87898-1522	87898-1532	-----	87898-1552	15	-----	2	38.10	35.56	10.81	9.65	5.84
-----	-----	87898-1524	87898-1534	-----	87898-1554	15	-----	4	38.10	35.56	10.81	9.65	5.84
-----	-----	87898-1525	87898-1535	-----	87898-1555	15	-----	5	38.10	35.56	10.81	9.65	5.84
-----	-----	87898-1526	87898-1536	-----	87898-1556	15	-----	6	38.10	35.56	10.81	9.65	5.84

-----	-----	-----	-----	-----	-----	-----	-----	-----	-----	-----	-----	-----	-----
-------	-------	-------	-------	-------	-------	-------	-------	-------	-------	-------	-------	-------	-------

SHT 2.+87898-0315 IEC NO: S2014-0976 DRWN:ATSEE 2014/04/14 CH'KD:FANNYWONG 2014/04/14 APPR:LBLEE 2014/09/11	DESCRIPTION REV	QUALITY SYMBOLS	GENERAL TOLERANCES (UNLESS SPECIFIED)	DIMENSION STYLE	SCALE	DESIGN UNITS	THIRD ANGLE PROJECTION	
		$\nabla_A = 0$ $\nabla_C = 0$ $\nabla_P = 0$	mm    INCH 4 PLACES ± --- ± --- 3 PLACES ± --- ± --- 2 PLACES ± 0.2 ± --- 1 PLACE ± --- ± --- ANGULAR ± 3 °	MM ONLY	NTS	METRIC	DRAWN BY: YLQIAO    DATE: 2005/03/14 CHECKED BY: PTLIM    DATE: 2005/03/29 APPROVED BY: MLONG    DATE: 2010/10/04 MATERIAL NO.	TITLE: CUSTOM HEADER 2.54MM PITCH SINGLE ROW SINGLE WAFER SMT HEADER MOLEX MOLEX INCORPORATED DOCUMENT NO. SD-87898-001
		DRAFT WHERE APPLICABLE MUST REMAIN WITHIN DIMENSIONS	SEE TABLE	SHEET NO. 6 OF 20 THIS DRAWING CONTAINS INFORMATION THAT IS PROPRIETARY TO MOLEX INCORPORATED AND SHOULD NOT BE USED WITHOUT WRITTEN PERMISSION				
		B12	SIZE A3					

PACKAGING OPTION PART NO.						CKT SIZE	VOID POSITION	PLATING TYPE	DIMENSION				
TRAY WITHOUT CAP	TRAY WITH CAP	TUBE WITHOUT CAP	TUBE WITH CAP	TAPE & REEL WITHOUT CAP	TAPE & REEL WITH CAP				A	B	G	F	M
-----	-----	87898-1621	87898-1631	-----	87898-1651	16	----	1	40.64	38.10	10.81	9.65	5.84
-----	-----	87898-1622	87898-1632	-----	87898-1652	16	----	2	40.64	38.10	10.81	9.65	5.84
-----	-----	87898-1624	87898-1634	-----	87898-1654	16	----	4	40.64	38.10	10.81	9.65	5.84
-----	-----	87898-1625	87898-1635	-----	87898-1655	16	----	5	40.64	38.10	10.81	9.65	5.84
-----	-----	87898-1626	87898-1636	-----	87898-1656	16	----	6	40.64	38.10	10.81	9.65	5.84
-----	-----	87898-1721	87898-1731	-----	87898-1751	17	----	1	43.18	40.64	10.81	9.65	5.84
-----	-----	87898-1722	87898-1732	-----	87898-1752	17	----	2	43.18	40.64	10.81	9.65	5.84
-----	-----	87898-1724	87898-1734	-----	87898-1754	17	----	4	43.18	40.64	10.81	9.65	5.84
-----	-----	87898-1725	87898-1735	-----	87898-1755	17	----	5	43.18	40.64	10.81	9.65	5.84
-----	-----	87898-1726	87898-1736	-----	87898-1756	17	----	6	43.18	40.64	10.81	9.65	5.84
-----	-----	87898-1821	87898-1831	-----	87898-1851	18	----	1	45.72	43.18	10.81	9.65	5.84
-----	-----	87898-1822	87898-1832	-----	87898-1852	18	----	2	45.72	43.18	10.81	9.65	5.84
-----	-----	87898-1824	87898-1834	-----	87898-1854	18	----	4	45.72	43.18	10.81	9.65	5.84
-----	-----	87898-1825	87898-1835	-----	87898-1855	18	----	5	45.72	43.18	10.81	9.65	5.84
-----	-----	87898-1826	87898-1836	-----	87898-1856	18	----	6	45.72	43.18	10.81	9.65	5.84

<b>SHT2,+87898-0315</b> IEC NO: S2014-0976 DRWN:ATSEE 2014/04/14 CHK'D:FANNYWONG 2014/04/14 APPR:LBLEE 2014/09/11	QUALITY SYMBOLS $\nabla_A = 0$ $\nabla_C = 0$ $\nabla_B = 0$	GENERAL TOLERANCES (UNLESS SPECIFIED)		DIMENSION STYLE <b>MM ONLY</b>		SCALE NTS	DESIGN UNITS METRIC	THIRD ANGLE PROJECTION			
				mm	INCH	DRAWN BY YLOIAO	DATE 2005/03/14	TITLE <b>CUSTOM HEADER 2.54MM PITCH SINGLE ROW SINGLE WAFER SMT HEADER</b>			
						CHECKED BY PTLIM	DATE 2005/03/29				
				ANGULAR $\pm 3^\circ$		APPROVED BY MLONG	DATE 2010/10/04	 <b>MOLEX INCORPORATED</b>			

DRAFT WHERE APPLICABLE MUST REMAIN WITHIN DIMENSIONS

MATERIAL NO. **SEE TABLE** DOCUMENT NO. **SD-87898-001** SHEET NO. **7 OF 20**

SIZE **A3** THIS DRAWING CONTAINS INFORMATION THAT IS PROPRIETARY TO MOLEX INCORPORATED AND SHOULD NOT BE USED WITHOUT WRITTEN PERMISSION

PACKAGING OPTION PART NO.						CKT SIZE	VOID POSITION	PLATING TYPE	DIMENSION				
TRAY WITHOUT CAP	TRAY WITH CAP	TUBE WITHOUT CAP	TUBE WITH CAP	TAPE & REEL WITHOUT CAP	TAPE & REEL WITH CAP				A	B	G	F	M
-----	-----	87898-1921	87898-1931	-----	87898-1951	19	----	1	48.26	45.72	10.81	9.65	5.84
-----	-----	87898-1922	87898-1932	-----	87898-1952	19	----	2	48.26	45.72	10.81	9.65	5.84
-----	-----	87898-1924	87898-1934	-----	87898-1954	19	----	4	48.26	45.72	10.81	9.65	5.84
-----	-----	87898-1925	87898-1935	-----	87898-1955	19	----	5	48.26	45.72	10.81	9.65	5.84
-----	-----	87898-1926	87898-1936	-----	87898-1956	19	----	6	48.26	45.72	10.81	9.65	5.84
-----	-----	87898-2021	87898-2031	-----	87898-2051	20	----	1	50.80	48.26	10.81	9.65	5.84
-----	-----	87898-2022	87898-2032	-----	87898-2052	20	----	2	50.80	48.26	10.81	9.65	5.84
-----	-----	87898-2024	87898-2034	-----	87898-2054	20	----	4	50.80	48.26	10.81	9.65	5.84
-----	-----	87898-2025	87898-2035	-----	87898-2055	20	----	5	50.80	48.26	10.81	9.65	5.84
-----	-----	87898-2026	87898-2036	-----	87898-2056	20	----	6	50.80	48.26	10.81	9.65	5.84
-----	-----	87898-2121	87898-2131	-----	87898-2151	21	----	1	53.34	50.80	10.81	9.65	5.84
-----	-----	87898-2122	87898-2132	-----	87898-2152	21	----	2	53.34	50.80	10.81	9.65	5.84
-----	-----	87898-2124	87898-2134	-----	87898-2154	21	----	4	53.34	50.80	10.81	9.65	5.84
-----	-----	87898-2125	87898-2135	-----	87898-2155	21	----	5	53.34	50.80	10.81	9.65	5.84
-----	-----	87898-2126	87898-2136	-----	87898-2156	21	----	6	53.34	50.80	10.81	9.65	5.84

-----	-----	-----	-----	-----	-----	-----	-----	-----	-----	-----	-----	-----	-----
-------	-------	-------	-------	-------	-------	-------	-------	-------	-------	-------	-------	-------	-------

SHT 2,+87898-0315 EC NO: S2014-0976 DRWN:ATSEE 2014/04/14 CH'KD:FANNYWONG 2014/04/14 APPR:LBLEE 2014/09/11	QUALITY SYMBOLS	GENERAL TOLERANCES (UNLESS SPECIFIED)	DIMENSION STYLE	SCALE	DESIGN UNITS	THIRD ANGLE PROJECTION
	$\nabla_A = 0$ $\nabla_C = 0$ $\nabla_P = 0$	mm INCH 4 PLACES $\pm$ --- $\pm$ --- 3 PLACES $\pm$ --- $\pm$ --- 2 PLACES $\pm 0.2$ $\pm$ --- 1 PLACE $\pm$ --- $\pm$ --- ANGULAR $\pm 3^\circ$	MM ONLY	NTS	METRIC	
		DRAFT WHERE APPLICABLE MUST REMAIN WITHIN DIMENSIONS	DRAWN BY: YLQIAO DATE: 2005/03/14 CHECKED BY: PTLIM DATE: 2005/03/29 APPROVED BY: MLONG DATE: 2010/10/04 MATERIAL NO. SEE TABLE	TITLE: CUSTOM HEADER 2.54MM PITCH SINGLE ROW SINGLE WAFER SMT HEADER MOLEX MOLEX INCORPORATED		
	B12		SIZE: A3 THIS DRAWING CONTAINS INFORMATION THAT IS PROPRIETARY TO MOLEX INCORPORATED AND SHOULD NOT BE USED WITHOUT WRITTEN PERMISSION	DOCUMENT NO. SD-87898-001	SHEET NO. 8 OF 20	



10 9 8 7 6 5 4 3 2 1

PACKAGING OPTION PART NO.						CKT SIZE	VOID POSITION	PLATING TYPE	DIMENSION				
TRAY WITHOUT CAP	TRAY WITH CAP	TUBE WITHOUT CAP	TUBE WITH CAP	TAPE & REEL WITHOUT CAP	TAPE & REEL WITH CAP				A	B	G	F	M
-----	-----	87898-2221	87898-2231	-----	-----	22	----	1	55.88	53.34	10.81	9.65	5.84
-----	-----	87898-2222	87898-2232	-----	-----	22	----	2	55.88	53.34	10.81	9.65	5.84
-----	-----	87898-2224	87898-2234	-----	-----	22	----	4	55.88	53.34	10.81	9.65	5.84
-----	-----	87898-2225	87898-2235	-----	-----	22	----	5	55.88	53.34	10.81	9.65	5.84
-----	-----	87898-2226	87898-2236	-----	-----	22	----	6	55.88	53.34	10.81	9.65	5.84
-----	-----												
-----	-----	87898-2321	87898-2331	-----	-----	23	----	1	58.42	55.88	10.81	9.65	5.84
-----	-----	87898-2322	87898-2332	-----	-----	23	----	2	58.42	55.88	10.81	9.65	5.84
-----	-----	87898-2324	87898-2334	-----	-----	23	----	4	58.42	55.88	10.81	9.65	5.84
-----	-----	87898-2325	87898-2335	-----	-----	23	----	5	58.42	55.88	10.81	9.65	5.84
-----	-----	87898-2326	87898-2336	-----	-----	23	----	6	58.42	55.88	10.81	9.65	5.84
-----	-----												
-----	-----	87898-2421	87898-2431	-----	-----	24	----	1	60.96	58.42	10.81	9.65	5.84
-----	-----	87898-2422	87898-2432	-----	-----	24	----	2	60.96	58.42	10.81	9.65	5.84
-----	-----	87898-2424	87898-2434	-----	-----	24	----	4	60.96	58.42	10.81	9.65	5.84
-----	-----	87898-2425	87898-2435	-----	-----	24	----	5	60.96	58.42	10.81	9.65	5.84
-----	-----	87898-2426	87898-2436	-----	-----	24	----	6	60.96	58.42	10.81	9.65	5.84

B

SHT2.+87898-0315 EIC NO: S2014-0976 DRW:NATSEE 2014/04/14 CHK:D-FANNYWONG 2014/04/14 APPR:LBLEE 2014/09/11	QUALITY SYMBOLS ▽=0 ▽=0 ▽=0	GENERAL TOLERANCES (UNLESS SPECIFIED)		DIMENSION STYLE <b>MM ONLY</b>		SCALE NTS	DESIGN UNITS METRIC	THIRD ANGLE PROJECTION	
		4 PLACES ± --- ± --- 3 PLACES ± --- ± --- 2 PLACES ± 0.2 ± --- 1 PLACE ± --- ± ---	mm INCH ± --- ± --- ± 0.2 ± --- ± --- ± ---	DRAWN BY YLQIAO	DATE 2005/03/14	TITLE CUSTOM HEADER 2.54MM PITCH SINGLE ROW SINGLE WAFER SMT HEADER			
		ANGULAR ± 3 °		CHECKED BY PTLIM	DATE 2005/03/29	MOLEX INCORPORATED			
		DRAFT WHERE APPLICABLE MUST REMAIN WITHIN DIMENSIONS		APPROVED BY MLONG	DATE 2010/10/04	MATERIAL NO. SEE TABLE	DOCUMENT NO. SD-87898-001	SHEET NO. 9 OF 20	

A

10 9 8 7 6 5 4 3 2 1

PACKAGING OPTION PART NO.						CKT SIZE	VOID POSITION	PLATING TYPE	DIMENSION				
TRAY WITHOUT CAP	TRAY WITH CAP	TUBE WITHOUT CAP	TUBE WITH CAP	TAPE & REEL WITHOUT CAP	TAPE & REEL WITH CAP				A	B	G	F	M
-----	-----	87898-2521	87898-2531	-----	-----	25	----	1	63.50	60.96	10.81	9.65	5.84
-----	-----	87898-2522	87898-2532	-----	-----	25	----	2	63.50	60.96	10.81	9.65	5.84
-----	-----	87898-2524	87898-2534	-----	-----	25	----	4	63.50	60.96	10.81	9.65	5.84
-----	-----	87898-2525	87898-2535	-----	-----	25	----	5	63.50	60.96	10.81	9.65	5.84
-----	-----	87898-2526	87898-2536	-----	-----	25	----	6	63.50	60.96	10.81	9.65	5.84
-----	-----	87898-2621	87898-2631	-----	-----	26	----	1	66.04	63.50	10.81	9.65	5.84
-----	-----	87898-2622	87898-2632	-----	-----	26	----	2	66.04	63.50	10.81	9.65	5.84
-----	-----	87898-2624	87898-2634	-----	-----	26	----	4	66.04	63.50	10.81	9.65	5.84
-----	-----	87898-2625	87898-2635	-----	-----	26	----	5	66.04	63.50	10.81	9.65	5.84
-----	-----	87898-2626	87898-2636	-----	-----	26	----	6	66.04	63.50	10.81	9.65	5.84
-----	-----	87898-2721	87898-2731	-----	-----	27	----	1	68.58	66.04	10.81	9.65	5.84
-----	-----	87898-2722	87898-2732	-----	-----	27	----	2	68.58	66.04	10.81	9.65	5.84
-----	-----	87898-2724	87898-2734	-----	-----	27	----	4	68.58	66.04	10.81	9.65	5.84
-----	-----	87898-2725	87898-2735	-----	-----	27	----	5	68.58	66.04	10.81	9.65	5.84
-----	-----	87898-2726	87898-2736	-----	-----	27	----	6	68.58	66.04	10.81	9.65	5.84

B

<b>SHT2+87898-0315</b> EC NO: S2014-0976 DRW:ATSE 2014/04/14 CHK:D-FANNYWONG 2014/04/14 APPR:BLEE 2014/09/11	QUALITY SYMBOLS $\nabla_F = 0$ $\nabla_F = 0$ $\nabla_F = 0$	GENERAL TOLERANCES (UNLESS SPECIFIED)		DIMENSION STYLE <b>MM ONLY</b>		SCALE NTS	DESIGN UNITS METRIC	THIRD ANGLE PROJECTION			
				mm	INCH	DRAWN BY YLOIAO	DATE 2005/03/14	TITLE CUSTOM HEADER			
		4 PLACES	$\pm$ ---	$\pm$ ---	CHECKED BY PTLIM	DATE 2005/03/29	SINGLE WAFER SMT HEADER				
		3 PLACES	$\pm$ ---	$\pm$ ---	APPROVED BY MLONG	DATE 2010/10/04	MOLEX INCORPORATED				
2 PLACES	$\pm$ 0.2	$\pm$ ---	ANGULAR $\pm 3^\circ$		MATERIAL NO. <b>SEE TABLE</b>	DOCUMENT NO. SD-87898-001	SHEET NO. 10 OF 20				
1 PLACE	$\pm$ ---	$\pm$ ---	DRAFT WHERE APPLICABLE MUST REMAIN WITHIN DIMENSIONS		THIS DRAWING CONTAINS INFORMATION THAT IS PROPRIETARY TO MOLEX INCORPORATED AND SHOULD NOT BE USED WITHOUT WRITTEN PERMISSION						

A

9 8 7 6 5 4 3 2 1

PACKAGING OPTION PART NO.						CKT SIZE	VOID POSITION	PLATING TYPE	DIMENSION				
TRAY WITHOUT CAP	TRAY WITH CAP	TUBE WITHOUT CAP	TUBE WITH CAP	TAPE & REEL WITHOUT CAP	TAPE & REEL WITH CAP				A	B	G	F	M
-----	-----	87898-2821	87898-2831	-----	-----	28	----	1	71.12	68.58	10.81	9.65	5.84
-----	-----	87898-2822	87898-2832	-----	-----	28	----	2	71.12	68.58	10.81	9.65	5.84
-----	-----	87898-2824	87898-2834	-----	-----	28	----	4	71.12	68.58	10.81	9.65	5.84
-----	-----	87898-2825	87898-2835	-----	-----	28	----	5	71.12	68.58	10.81	9.65	5.84
-----	-----	87898-2826	87898-2836	-----	-----	28	----	6	71.12	68.58	10.81	9.65	5.84
-----	-----	87898-2921	87898-2931	-----	-----	29	----	1	73.66	71.12	10.81	9.65	5.84
-----	-----	87898-2922	87898-2932	-----	-----	29	----	2	73.66	71.12	10.81	9.65	5.84
-----	-----	87898-2924	87898-2934	-----	-----	29	----	4	73.66	71.12	10.81	9.65	5.84
-----	-----	87898-2925	87898-2935	-----	-----	29	----	5	73.66	71.12	10.81	9.65	5.84
-----	-----	87898-2926	87898-2936	-----	-----	29	----	6	73.66	71.12	10.81	9.65	5.84
-----	-----	87898-3021	87898-3031	-----	-----	30	----	1	76.20	73.66	10.81	9.65	5.84
-----	-----	87898-3022	87898-3032	-----	-----	30	----	2	76.20	73.66	10.81	9.65	5.84
-----	-----	87898-3024	87898-3034	-----	-----	30	----	4	76.20	73.66	10.81	9.65	5.84
-----	-----	87898-3025	87898-3035	-----	-----	30	----	5	76.20	73.66	10.81	9.65	5.84
-----	-----	87898-3026	87898-3036	-----	-----	30	----	6	76.20	73.66	10.81	9.65	5.84

SHT2.+87898-0315 EC NO: S2014-0976 DRW:ATSEE 2014/04/14 CHKD:FANNY WONG 2014/04/14 APPR: LBLEE 2014/09/11	REV DESCRIPTION B12	QUALITY SYMBOLS	GENERAL TOLERANCES (UNLESS SPECIFIED)	DIMENSION STYLE MM ONLY		SCALE NTS	DESIGN UNITS METRIC	THIRD ANGLE PROJECTION																										
		$\nabla_A = 0$ $\nabla_G = 0$ $\nabla_P = 0$	<table border="1"> <tr><th colspan="2">mm</th><th>INCH</th></tr> <tr><td>4 PLACES</td><td>± ---</td><td>± ---</td></tr> <tr><td>3 PLACES</td><td>± ---</td><td>± ---</td></tr> <tr><td>2 PLACES</td><td>± 0.2</td><td>± ---</td></tr> <tr><td>1 PLACE</td><td>± ---</td><td>± ---</td></tr> </table>	mm		INCH	4 PLACES	± ---	± ---	3 PLACES	± ---	± ---	2 PLACES	± 0.2	± ---	1 PLACE	± ---	± ---	<table border="1"> <tr><td>DRAWN BY</td><td>DATE</td></tr> <tr><td>YLQIAO</td><td>2005/03/14</td></tr> <tr><td>CHECKED BY</td><td>DATE</td></tr> <tr><td>PTLIM</td><td>2005/03/29</td></tr> <tr><td>APPROVED BY</td><td>DATE</td></tr> <tr><td>MLONG</td><td>2010/10/04</td></tr> </table>	DRAWN BY	DATE	YLQIAO	2005/03/14	CHECKED BY	DATE	PTLIM	2005/03/29	APPROVED BY	DATE	MLONG	2010/10/04	TITLE	CUSTOM HEADER 2.54MM PITCH SINGLE ROW SINGLE WAFER SMT HEADER	
		mm		INCH																														
		4 PLACES	± ---	± ---																														
3 PLACES	± ---	± ---																																
2 PLACES	± 0.2	± ---																																
1 PLACE	± ---	± ---																																
DRAWN BY	DATE																																	
YLQIAO	2005/03/14																																	
CHECKED BY	DATE																																	
PTLIM	2005/03/29																																	
APPROVED BY	DATE																																	
MLONG	2010/10/04																																	
DRAFT WHERE APPLICABLE MUST REMAIN WITHIN DIMENSIONS			SEE TABLE	MATERIAL NO.		DOCUMENT NO.		SHEET NO.																										
			SIZE A3	THIS DRAWING CONTAINS INFORMATION THAT IS PROPRIETARY TO MOLEX INCORPORATED AND SHOULD NOT BE USED WITHOUT WRITTEN PERMISSION																														

PACKAGING OPTION PART NO.

F

E

D

C

B

A

F

E

D

C

B

A

TRAY WITHOUT CAP	TRAY WITH CAP	TUBE WITHOUT CAP	TUBE WITH CAP	TAPE & REEL WITHOUT CAP	TAPE & REEL WITH CAP	CKT SIZE	VOID POSITION	PLATING TYPE	DIMENSION				
									A	B	G	F	M
-----	-----	87898-3121	87898-3131	-----	-----	31	----	1	78.74	76.20	10.81	9.65	5.84
-----	-----	87898-3122	87898-3132	-----	-----	31	----	2	78.74	76.20	10.81	9.65	5.84
-----	-----	87898-3124	87898-3134	-----	-----	31	----	4	78.74	76.20	10.81	9.65	5.84
-----	-----	87898-3125	87898-3135	-----	-----	31	----	5	78.74	76.20	10.81	9.65	5.84
-----	-----	87898-3126	87898-3136	-----	-----	31	----	6	78.74	76.20	10.81	9.65	5.84
-----	-----												
-----	-----	87898-3221	87898-3231	-----	-----	32	----	1	81.28	78.74	10.81	9.65	5.84
-----	-----	87898-3222	87898-3232	-----	-----	32	----	2	81.28	78.74	10.81	9.65	5.84
-----	-----	87898-3224	87898-3234	-----	-----	32	----	4	81.28	78.74	10.81	9.65	5.84
-----	-----	87898-3225	87898-3235	-----	-----	32	----	5	81.28	78.74	10.81	9.65	5.84
-----	-----	87898-3226	87898-3236	-----	-----	32	----	6	81.28	78.74	10.81	9.65	5.84
-----	-----												
-----	-----	87898-3321	87898-3331	-----	-----	33	----	1	83.82	81.28	10.81	9.65	5.84
-----	-----	87898-3322	87898-3332	-----	-----	33	----	2	83.82	81.28	10.81	9.65	5.84
-----	-----	87898-3324	87898-3334	-----	-----	33	----	4	83.82	81.28	10.81	9.65	5.84
-----	-----	87898-3325	87898-3335	-----	-----	33	----	5	83.82	81.28	10.81	9.65	5.84
-----	-----	87898-3326	87898-3336	-----	-----	33	----	6	83.82	81.28	10.81	9.65	5.84

SHT 2.+87898-0315 EC NO: S2014-0976 DRWN:ATSEE 2014/04/14 CH'KD:FANNYWONG 2014/04/14 APPR:LBLEE 2014/09/11	DESCRIPTION REV	QUALITY SYMBOLS	GENERAL TOLERANCES (UNLESS SPECIFIED)	DIMENSION STYLE	SCALE	DESIGN UNITS	THIRD ANGLE PROJECTION	
		$\nabla_A = 0$ $\nabla_C = 0$ $\nabla_P = 0$	mm    INCH	MM ONLY	NTS	METRIC	TITLE	
		4 PLACES ± --- ± --- 3 PLACES ± --- ± --- 2 PLACES ± 0.2 ± --- 1 PLACE ± --- ± --- ANGULAR ± 3 °	DRAWN BY: YLQIAO    DATE: 2005/03/14 CHECKED BY: PTLIM    DATE: 2005/03/29 APPROVED BY: MLONG    DATE: 2010/10/04	CUSTOM HEADER 2.54MM PITCH SINGLE ROW SINGLE WAFER SMT HEADER				
		DRAFT WHERE APPLICABLE MUST REMAIN WITHIN DIMENSIONS	MATERIAL NO. SEE TABLE	MOLEX INCORPORATED DOCUMENT NO. SD-87898-001	SHEET NO. 12 OF 20			

PACKAGING OPTION PART NO.										CKT SIZE	VOID POSITION	PLATING TYPE	DIMENSION				
TRAY WITHOUT CAP	TRAY WITH CAP	TUBE WITHOUT CAP	TUBE WITH CAP	TAPE & REEL WITHOUT CAP	TAPE & REEL WITH CAP	A	B	G	F				M				
-----	-----	87898-3421	87898-3431	-----	-----	34	----	1	86.36	83.82	10.81	9.65	5.84				
-----	-----	87898-3422	87898-3432	-----	-----	34	----	2	86.36	83.82	10.81	9.65	5.84				
-----	-----	87898-3424	87898-3434	-----	-----	34	----	4	86.36	83.82	10.81	9.65	5.84				
-----	-----	87898-3425	87898-3435	-----	-----	34	----	5	86.36	83.82	10.81	9.65	5.84				
-----	-----	87898-3426	87898-3436	-----	-----	34	----	6	86.36	83.82	10.81	9.65	5.84				
-----	-----																
-----	-----	87898-3521	87898-3531	-----	-----	35	----	1	88.90	86.36	10.81	9.65	5.84				
-----	-----	87898-3522	87898-3532	-----	-----	35	----	2	88.90	86.36	10.81	9.65	5.84				
-----	-----	87898-3524	87898-3534	-----	-----	35	----	4	88.90	86.36	10.81	9.65	5.84				
-----	-----	87898-3525	87898-3535	-----	-----	35	----	5	88.90	86.36	10.81	9.65	5.84				
-----	-----	87898-3526	87898-3536	-----	-----	35	----	6	88.90	86.36	10.81	9.65	5.84				
-----	-----																
-----	-----	87898-3621	87898-3631	-----	-----	36	----	1	91.44	88.90	10.81	9.65	5.84				
-----	-----	87898-3622	87898-3632	-----	-----	36	----	2	91.44	88.90	10.81	9.65	5.84				
-----	-----	87898-3624	87898-3634	-----	-----	36	----	4	91.44	88.90	10.81	9.65	5.84				
-----	-----	87898-3625	87898-3635	-----	-----	36	----	5	91.44	88.90	10.81	9.65	5.84				
-----	-----	87898-3626	87898-3636	-----	-----	36	----	6	91.44	88.90	10.81	9.65	5.84				

--	--	--	--	--	--	--	--	--	--	--	--	--	--	--

SHT2.+87898-0315 IEC NO: S2014.-0976 DRWN:ATSEE 2014/04/14 CH'KD:FANNYWONG 2014/04/14 APPR:LBLEE 2014/09/11	QUALITY SYMBOLS $\nabla_F = 0$ $\nabla_F = 0$ $\nabla_F = 0$	GENERAL TOLERANCES (UNLESS SPECIFIED)		DIMENSION STYLE MM ONLY		SCALE NTS	DESIGN UNITS METRIC	THIRD ANGLE PROJECTION				
				mm	INCH	DRAWN BY YLOIAO	DATE 2005/03/14	TITLE CUSTOM HEADER 2.54MM PITCH SINGLE ROW SINGLE WAFER SMT HEADER				
				4 PLACES	$\pm$ ---	$\pm$ ---	CHECKED BY PTLIM	DATE 2005/03/29	APPROVED BY MLONG			
				3 PLACES	$\pm$ ---	$\pm$ ---	DATE 2010/10/04	MATERIAL NO. SEE TABLE				
		2 PLACES	$\pm$ 0.2	$\pm$ ---			MOLEX INCORPORATED		DOCUMENT NO. SD-87898-001	SHEET NO. 13 OF 20		
		1 PLACE	$\pm$ ---	$\pm$ ---			THIS DRAWING CONTAINS INFORMATION THAT IS PROPRIETARY TO MOLEX INCORPORATED AND SHOULD NOT BE USED WITHOUT WRITTEN PERMISSION					
		ANGULAR $\pm 3^\circ$		DRAFT WHERE APPLICABLE MUST REMAIN WITHIN DIMENSIONS								

PACKAGING OPTION PART NO.

F	TRAY WITHOUT CAP		TRAY WITH CAP		TUBE WITHOUT CAP	TUBE WITH CAP	TAPE & REEL WITHOUT CAP	TAPE & REEL WITH CAP	CKT SIZE	VOID POSITION	PLATING TYPE	DIMENSION				
	A	B	G	F								M				
	-----	-----	87898-3721	87898-3731	-----	-----	-----	-----	37	-----	1	93.98	91.44	10.81	9.65	5.84
	-----	-----	87898-3722	87898-3732	-----	-----	-----	-----	37	-----	2	93.98	91.44	10.81	9.65	5.84
	-----	-----	87898-3724	87898-3734	-----	-----	-----	-----	37	-----	4	93.98	91.44	10.81	9.65	5.84
	-----	-----	87898-3725	87898-3735	-----	-----	-----	-----	37	-----	5	93.98	91.44	10.81	9.65	5.84
	-----	-----	87898-3726	87898-3736	-----	-----	-----	-----	37	-----	6	93.98	91.44	10.81	9.65	5.84
E																
	-----	-----	87898-3821	87898-3831	-----	-----	-----	-----	38	-----	1	96.52	93.98	10.81	9.65	5.84
	-----	-----	87898-3822	87898-3832	-----	-----	-----	-----	38	-----	2	96.52	93.98	10.81	9.65	5.84
	-----	-----	87898-3824	87898-3834	-----	-----	-----	-----	38	-----	4	96.52	93.98	10.81	9.65	5.84
	-----	-----	87898-3825	87898-3835	-----	-----	-----	-----	38	-----	5	96.52	93.98	10.81	9.65	5.84
D																
	-----	-----	87898-3826	87898-3836	-----	-----	-----	-----	38	-----	6	96.52	93.98	10.81	9.65	5.84
	-----	-----	87898-3921	87898-3931	-----	-----	-----	-----	39	-----	1	99.06	96.52	10.81	9.65	5.84
	-----	-----	87898-3922	87898-3932	-----	-----	-----	-----	39	-----	2	99.06	96.52	10.81	9.65	5.84
	-----	-----	87898-3924	87898-3934	-----	-----	-----	-----	39	-----	4	99.06	96.52	10.81	9.65	5.84
C																
	-----	-----	87898-3925	87898-3935	-----	-----	-----	-----	39	-----	5	99.06	96.52	10.81	9.65	5.84
	-----	-----	87898-3926	87898-3936	-----	-----	-----	-----	39	-----	6	99.06	96.52	10.81	9.65	5.84

SHT2.+87898-0315 EC NO: S2014-0976 DRW:ATSEE 2014/04/14 CHK:D-FANNY WONG 2014/04/14 APPR: LBLEE 2014/09/11	REV DESCRIPTION B12	QUALITY SYMBOLS	GENERAL TOLERANCES (UNLESS SPECIFIED)	DIMENSION STYLE	SCALE	DESIGN UNITS	THIRD ANGLE PROJECTION
		$F_A=0$ $F_G=0$ $F_P=0$	mm INCH	MM ONLY	NTS	METRIC	
		4 PLACES $\pm$ --- $\pm$ --- 3 PLACES $\pm$ --- $\pm$ --- 2 PLACES $\pm$ 0.2 $\pm$ --- 1 PLACE $\pm$ --- $\pm$ --- ANGULAR $\pm$ 3 °	DRAWN BY YLQIAO DATE 2005/03/14 CHECKED BY PTLIM DATE 2005/03/29 APPROVED BY MLONG DATE 2010/10/04 MATERIAL NO.	TITLE CUSTOM HEADER 2.54MM PITCH SINGLE ROW SINGLE WAFER SMT HEADER MOLEX INCORPORATED			
		DRAFT WHERE APPLICABLE MUST REMAIN WITHIN DIMENSIONS	SEE TABLE THIS DRAWING CONTAINS INFORMATION THAT IS PROPRIETARY TO MOLEX INCORPORATED AND SHOULD NOT BE USED WITHOUT WRITTEN PERMISSION	DOCUMENT NO. SD-87898-001 SHEET NO. 14 OF 20			

PACKAGING OPTION PART NO.						CKT SIZE	VOID POSITION	PLATING TYPE	DIMENSION				
TRAY WITHOUT CAP	TRAY WITH CAP	TUBE WITHOUT CAP	TUBE WITH CAP	TAPE & REEL WITHOUT CAP	TAPE & REEL WITH CAP				A	B	G	F	M
-----	-----	87898-4021	87898-4031	-----	-----	40	----	1	101.6	99.06	10.81	9.65	5.84
-----	-----	87898-4022	87898-4032	-----	-----	40	----	2	101.6	99.06	10.81	9.65	5.84
-----	-----	87898-4024	87898-4034	-----	-----	40	----	4	101.6	99.06	10.81	9.65	5.84
-----	-----	87898-4025	87898-4035	-----	-----	40	----	5	101.6	99.06	10.81	9.65	5.84
-----	-----	87898-4026	87898-4036	-----	-----	40	----	6	101.6	99.06	10.81	9.65	5.84

<b>SHT 2,+87898-0315</b> EC NO: S2014-0976 DRWN:ATSEE 2014/04/14 CHK'D:FANNYWONG 2014/04/14 APPR:LBLLEE 2014/09/11	QUALITY SYMBOLS	GENERAL TOLERANCES (UNLESS SPECIFIED)		DIMENSION STYLE <b>MM ONLY</b>		SCALE NTS	DESIGN UNITS METRIC	THIRD ANGLE PROJECTION	
	$\nabla_A = 0$	4 PLACES	mm	INCH	DRAWN BY YLQ1A0	DATE 2005/03/14	TITLE CUSTOM HEADER		
	$\nabla_C = 0$	3 PLACES	$\pm$ ---	$\pm$ ---	CHECKED BY PTLIM	DATE 2005/03/29	2.54MM PITCH SINGLE ROW SINGLE WAFER SMT HEADER		
	$\nabla_F = 0$	2 PLACES	$\pm$ 0.2	$\pm$ ---	APPROVED BY MLONG	DATE 2010/10/04	MOLEX INCORPORATED		
	1 PLACE	$\pm$ ---	$\pm$ ---	ANGULAR $\pm$ 3 °		MATERIAL NO. <b>SEE TABLE</b>	DOCUMENT NO. SD-87898-001	SHEET NO. 15 OF 20	
	DRAFT WHERE APPLICABLE MUST REMAIN WITHIN DIMENSIONS		THIS DRAWING CONTAINS INFORMATION THAT IS PROPRIETARY TO MOLEX INCORPORATED AND SHOULD NOT BE USED WITHOUT WRITTEN PERMISSION						

10 9 8 7 6 5 4 3 2 1

**PART WITHOUT CAP  
IN TUBE ORIENTATION**

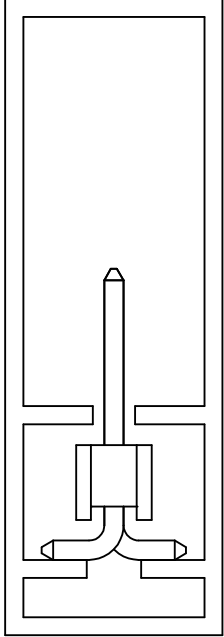

**PART WITH CAP  
IN TUBE ORIENTATION**

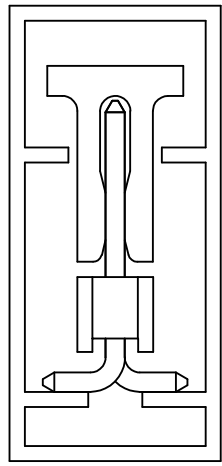

SHT2.+87898-0315 IEC NO: S2014-0976 DRWN:ATSEE 2014/04/14 CHY:KDF:ANNYWONG 2014/04/14 APPR:LBLEE 2014/09/11	DESCRIPTION REV	QUALITY SYMBOLS	GENERAL TOLERANCES (UNLESS SPECIFIED)		DIMENSION STYLE MM ONLY		SCALE NTS	DESIGN UNITS METRIC	THIRD ANGLE PROJECTION	
		$\nabla_F = 0$ $\nabla_{F_1} = 0$ $\nabla_{F_2} = 0$	4 PLACES ± --- ± --- 3 PLACES ± --- ± --- 2 PLACES ± 0.2 ± --- 1 PLACE ± --- ± ---	mm    INCH	DRAWN BY YLO1AO	DATE 2005/03/14	TITLE CUSTOM HEADER 2.54MM PITCH SINGLE ROW SINGLE WAFER SMT HEADER			
			ANGULAR ± 3 °		CHECKED BY PTLIM	DATE 2005/03/29	APPROVED BY MLONG			
			DRAFT WHERE APPLICABLE MUST REMAIN WITHIN DIMENSIONS		MATERIAL NO. SEE TABLE	DATE 2010/10/04	MOLEX INCORPORATED DOCUMENT NO. SD-87898-001		SHEET NO. 16 OF 20	

9 8 7 6 5 4 3 2 1



CKT	DIMENSION				
	Bo	Ao	Ko	F	W
2	8.02	5.20	13.60	11.50	24.00
3	8.02	5.20	13.60	11.50	24.00
4	10.55	5.20	11.30	11.50	24.00

### EMBOSSED CARRIER TYPE 'A'

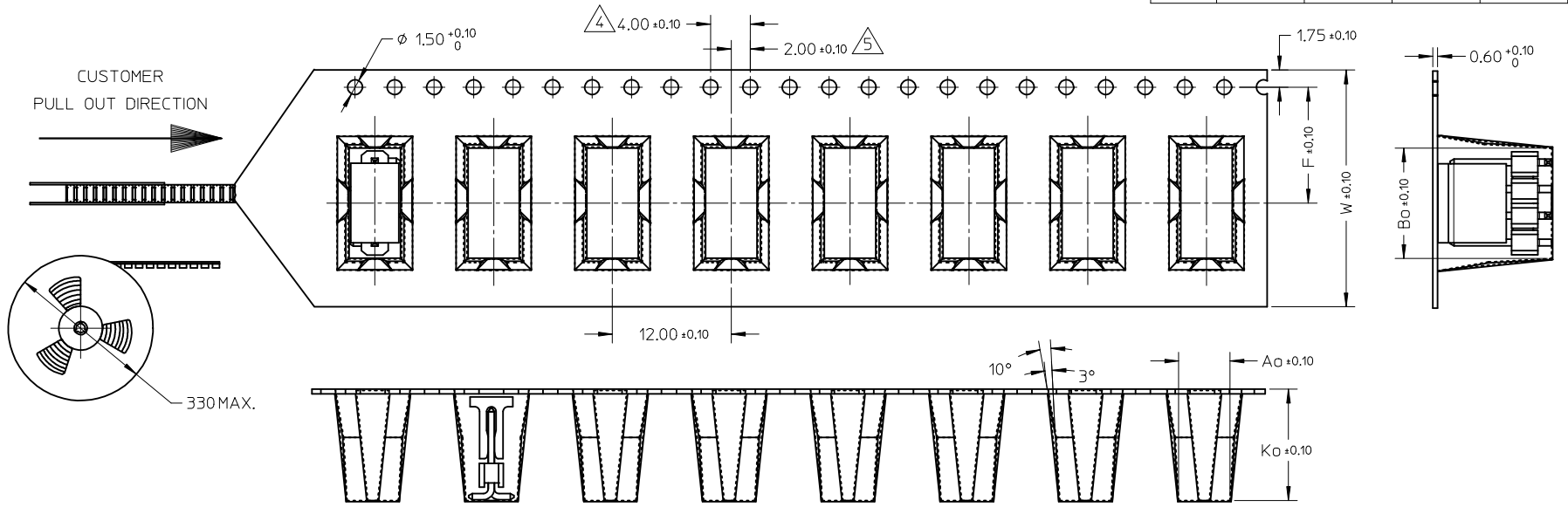

**PART PACK  
IN E/TAPE  
ORIENTATION  
(FOR REF USE)**

**NOTES:**

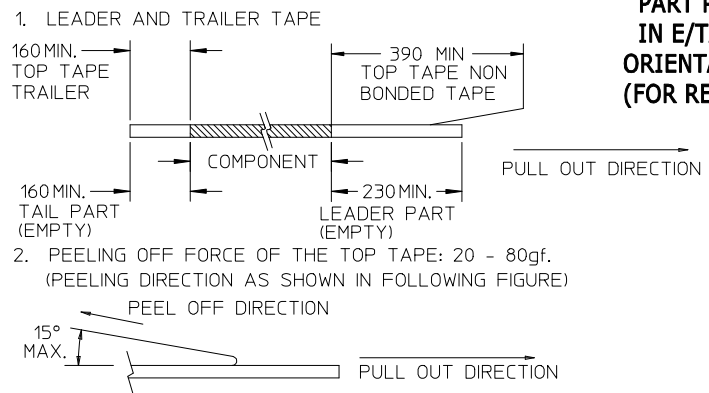

- 3. MATERIAL: BLACK P.S CONDUCTIVE, BLACK
- 4. MEASURED FROM CENTRELINE OF SPROCKET HOLE TO CENTRELINE OF SPOCKET
- 5. CUMULATIVE TOLERANCE OF 10 SPROCKET HOLE IS ±0.20mm
- 6. A0 AND B0 ARE MEASURED FROM ABOVE POCKET BASE 0.30mm
- 7. TAPE AND REEL SPECIFICATION IS AS PER EIA-481.
- 8. TAPE AND REEL QUANTITY : 440PCS/REEL
- 9. THE TAPE IS TREATED FOR ANTI-STATIC.
- 10. ALL RADIUS ARE 0.30MM UNLESS SPECIFY
- 11. SURFACE RESISTIVITY 10<sup>3</sup> TO 10 OHMS.

SHT2.+87898-0315 EC NO: S2014-0976 DRW:NAT/SEE CHK'D:FANNY/MONG APPR:LBLEE 2014/04/14 2014/04/14 2014/09/11	QUALITY SYMBOLS	GENERAL TOLERANCES (UNLESS SPECIFIED)	DIMENSION STYLE	SCALE	DESIGN UNITS	THIRD ANGLE PROJECTION	
	$\nabla_A = 0$ $\nabla_C = 0$ $\nabla_B = 0$	mm    INCH 4 PLACES ± --- ± --- 3 PLACES ± --- ± --- 2 PLACES ± 0.2 ± --- 1 PLACE ± --- ± --- ANGULAR ± 3 °	MM ONLY	NTS	METRIC		
		DRAFT WHERE APPLICABLE MUST REMAIN WITHIN DIMENSIONS	DRAWN BY: YLQ1A0    DATE: 2005/03/14 CHECKED BY: PTLIM    DATE: 2005/03/29 APPROVED BY: MLONG    DATE: 2010/10/04	TITLE	CUSTOM HEADER 2.54MM PITCH SINGLE ROW SINGLE WAFER SMT HEADER		
		SEE TABLE	MATERIAL NO.	DOCUMENT NO.	MOLEX INCORPORATED SD-87898-001		

CKT	DIMENSION				
	Bo	Ao	Ko	F	W
5	13.10	5.20	11.30	11.50	24.00

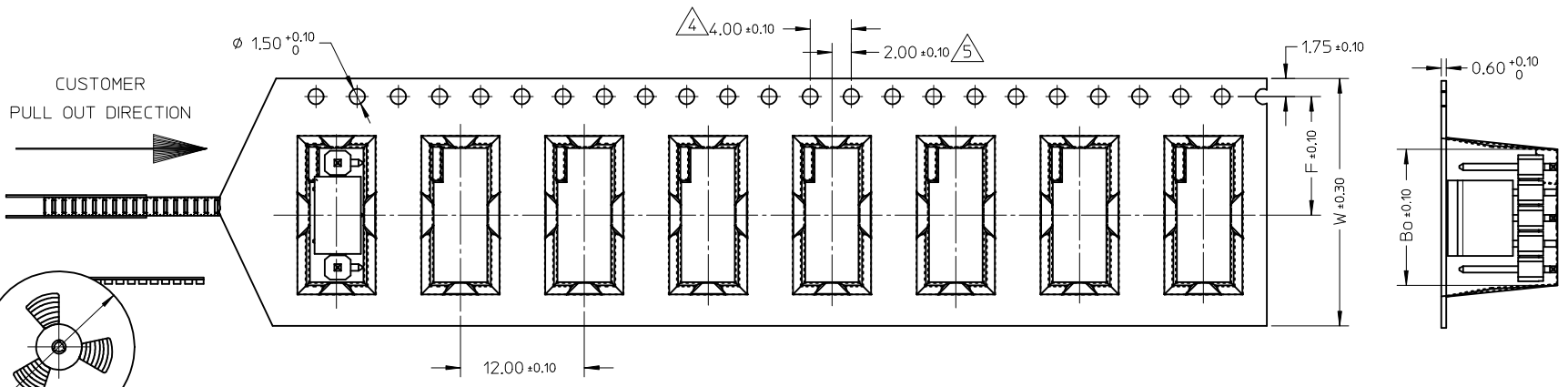

NOTES:

1. LEADER AND TRAILER TAPE

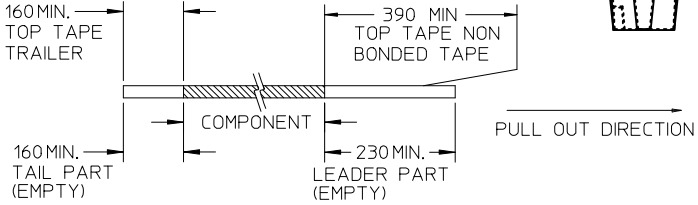

2. PEELING OFF FORCE OF THE TOP TAPE: 20 - 80gf. (PEELING DIRECTION AS SHOWN IN FOLLOWING FIGURE)



- 3. MATERIAL: BLACK P.S CONDUCTIVE, BLACK
- 4. MEASURED FROM CENTRELINE OF SPROCKET HOLE TO CENTRELINE OF SPOCKET
- 5. CUMULATIVE TOLERANCE OF 10 SPROCKET HOLE IS  $\pm 0.20\text{mm}$
- 6. A0 AND B0 ARE MEASURED FROM ABOVE POCKET BASE 0.30mm
- 7. TAPE AND REEL SPECIFICATION IS AS PER EIA-481.
- 8. TAPE AND REEL QUANTITY : 440PCS/REEL
- 9. THE TAPE IS TREATED FOR ANTI-STATIC.
- 10. ALL RADIUS ARE 0.30MM UNLESS SPECIFY
- 11. SURFACE RESISTIVITY  $10^3$  TO  $10^8$  OHMS.

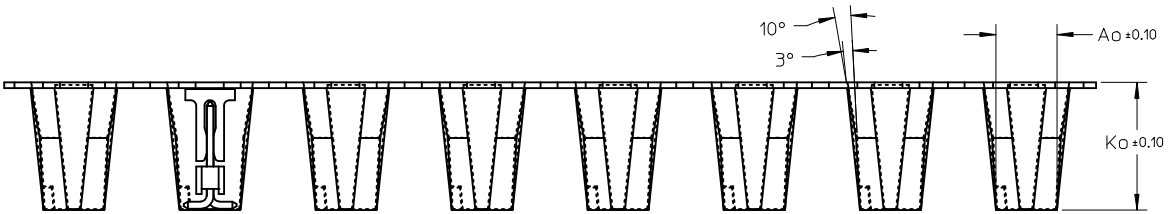

**PART PACK IN E/TAPE ORIENTATION (FOR REF USE)**

SHT2+87898-0315 EC NO: S2014-0976 DRWN:ATSEE 2014/04/14 CHKD:FANNYWONG 2014/04/14 APPR:BLEE 2014/09/11	QUALITY SYMBOLS	GENERAL TOLERANCES (UNLESS SPECIFIED)	DIMENSION STYLE	SCALE	DESIGN UNITS	THIRD ANGLE PROJECTION														
	$\nabla F = 0$ $\nabla E = 0$ $\nabla A = 0$	<table border="1"> <tr> <th></th> <th>mm</th> <th>INCH</th> </tr> <tr> <td>4 PLACES</td> <td><math>\pm</math> ---</td> <td><math>\pm</math> ---</td> </tr> <tr> <td>3 PLACES</td> <td><math>\pm</math> ---</td> <td><math>\pm</math> ---</td> </tr> <tr> <td>2 PLACES</td> <td><math>\pm 0.2</math></td> <td><math>\pm</math> ---</td> </tr> <tr> <td>1 PLACE</td> <td><math>\pm</math> ---</td> <td><math>\pm</math> ---</td> </tr> </table>		mm	INCH	4 PLACES	$\pm$ ---	$\pm$ ---	3 PLACES	$\pm$ ---	$\pm$ ---	2 PLACES	$\pm 0.2$	$\pm$ ---	1 PLACE	$\pm$ ---	$\pm$ ---	MM ONLY	NTS	METRIC
	mm	INCH																		
4 PLACES	$\pm$ ---	$\pm$ ---																		
3 PLACES	$\pm$ ---	$\pm$ ---																		
2 PLACES	$\pm 0.2$	$\pm$ ---																		
1 PLACE	$\pm$ ---	$\pm$ ---																		

REV	DESCRIPTION	DRAWN BY	DATE	TITLE
	B12	YLO1A0	2005/03/14	CUSTOM HEADER 2.54MM PITCH SINGLE ROW SINGLE WAFER SMT HEADER
		CHECKED BY	DATE	
		PTL IM	2005/03/29	
		APPROVED BY	DATE	
		MLONG	2010/10/04	
		MATERIAL NO.	DOCUMENT NO.	
		SEE TABLE		SD-87898-001
		SIZE	THIS DRAWING CONTAINS INFORMATION THAT IS PROPRIETARY TO MOLEX INCORPORATED AND SHOULD NOT BE USED WITHOUT WRITTEN PERMISSION	
		A3		

4 PLACES	$\pm$ ---	$\pm$ ---
3 PLACES	$\pm$ ---	$\pm$ ---
2 PLACES	$\pm 0.2$	$\pm$ ---
1 PLACE	$\pm$ ---	$\pm$ ---
ANGULAR $\pm 3^\circ$		

DRAWN BY		DATE	TITLE
YLO1A0		2005/03/14	CUSTOM HEADER 2.54MM PITCH SINGLE ROW SINGLE WAFER SMT HEADER
CHECKED BY		DATE	
PTL IM		2005/03/29	
APPROVED BY		DATE	
MLONG		2010/10/04	
MATERIAL NO.		DOCUMENT NO.	
SEE TABLE			SD-87898-001
SIZE			SHEET NO.
A3			18 OF 20

CKT	DIMENSION							TYPE	QTY/ REEL
	M	Bo	So	Ao	Ko	F	W		
6	11.50	15.65	28.40	5.20	16.90	14.20	32.00	A	150
6	5.84	15.65	28.40	5.20	11.30	14.20	32.00	B	440
8		20.70	40.40	5.20	11.30	20.20	44.00		
10		25.80	40.40	5.20	11.30	20.20	44.00		
12		30.90	52.40	5.20	11.30	26.20	56.00		
14		35.95	52.40	5.20	11.30	26.20	56.00		
16		41.05	52.40	5.20	11.30	26.20	56.00		
18		46.20	68.40	5.20	11.30	34.20	72.00		
20	51.20	68.40	5.20	11.30	34.20	72.00			

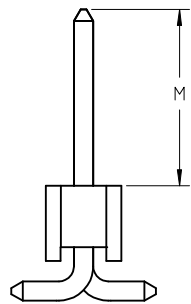
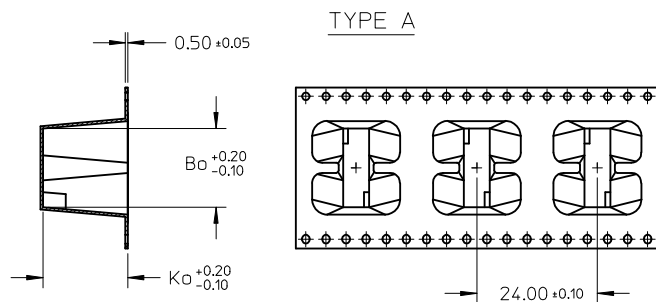

FOR ILLUSTRATION ONLY

NOTES:

1. LEADER AND TRAILER TAPE

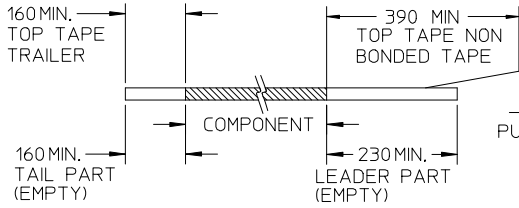

2. PEELING OFF FORCE OF THE TOP TAPE: 20 - 80gf. (PEELING DIRECTION AS SHOWN IN FOLLOWING FIGURE)



- 3. MATERIAL: BLACK P.S CONDUCTIVE, BLACK
- 4. MEASURED FROM CENTRELINE OF SPROCKET HOLE TO CENTRELINE OF SPOCKET
- 5. CUMULATIVE TOLERANCE OF 10 SPROCKET HOLE IS  $\pm 0.20\text{mm}$
- 6. A0 AND B0 ARE MEASURED FROM ABOVE POCKET BASE 0.30mm
- 7. TAPE AND REEL SPECIFICATION IS AS PER EIA-481.
- 8. TAPE AND REEL QUANTITY : SEE TABLE
- 9. THE TAPE IS TREATED FOR ANTI-STATIC.
- 10. ALL RADIUS ARE 0.30MM UNLESS SPECIFY
- 11. SURFACE RESISTIVITY  $10^3$  TO  $10$  OHMS.

330MAX.

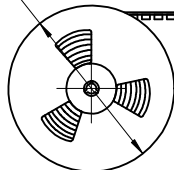

PULL OUT DIRECTION

TYPE B

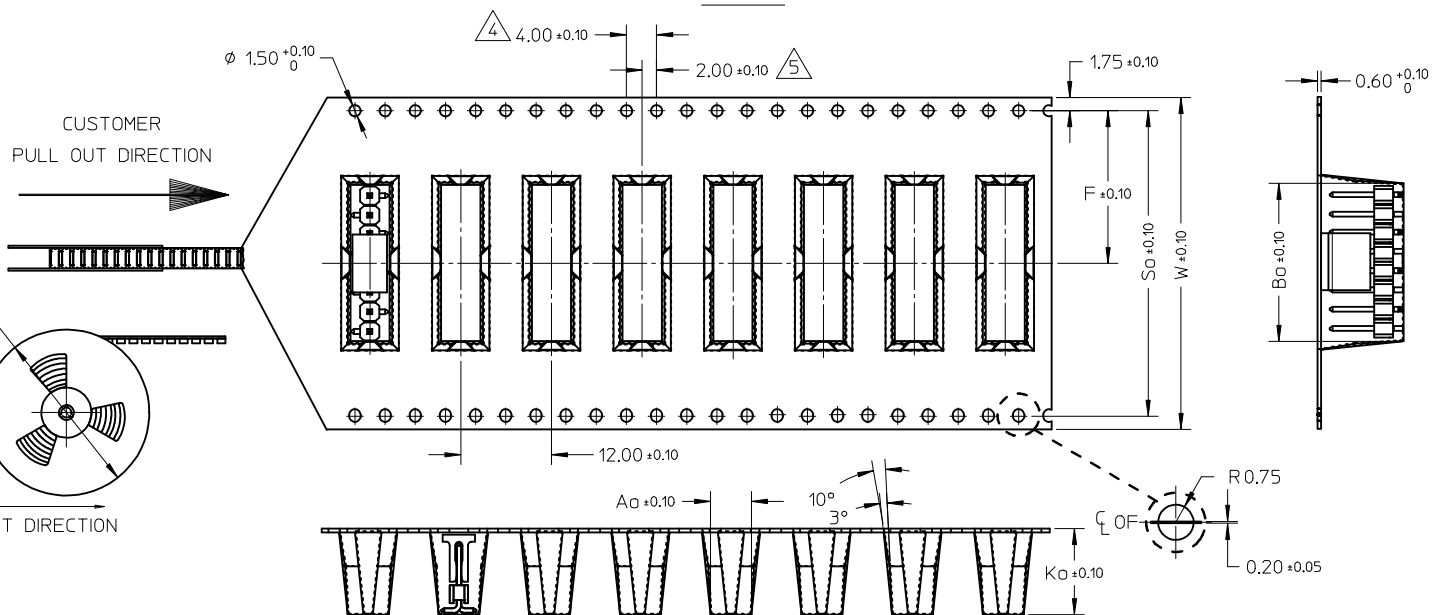

PART PACK IN E/TAPE ORIENTATION(FOR REF USE)

SHT2.+87898-0315 EC NO: S2014-0976 DRW:NATSEE 2014/04/14 CHK:D-FANNYWONG 2014/04/14 APPR:LBLEE 2014/09/11 REV B12	QUALITY SYMBOLS $\nabla F=0$ $\nabla F=0$ $\nabla F=0$	GENERAL TOLERANCES (UNLESS SPECIFIED) <table border="1"> <tr> <th></th> <th>mm</th> <th>INCH</th> </tr> <tr> <td>4 PLACES</td> <td><math>\pm</math>---</td> <td><math>\pm</math>---</td> </tr> <tr> <td>3 PLACES</td> <td><math>\pm</math>---</td> <td><math>\pm</math>---</td> </tr> <tr> <td>2 PLACES</td> <td><math>\pm 0.2</math></td> <td><math>\pm</math>---</td> </tr> <tr> <td>1 PLACE</td> <td><math>\pm</math>---</td> <td><math>\pm</math>---</td> </tr> </table>		mm	INCH	4 PLACES	$\pm$ ---	$\pm$ ---	3 PLACES	$\pm$ ---	$\pm$ ---	2 PLACES	$\pm 0.2$	$\pm$ ---	1 PLACE	$\pm$ ---	$\pm$ ---	DIMENSION STYLE <b>MM ONLY</b> DRAWN BY: YLQ1A0 DATE: 2005/03/14 CHECKED BY: PTL IM DATE: 2005/03/29 APPROVED BY: MLONG DATE: 2010/10/04	SCALE <b>NTS</b> DESIGN UNITS <b>METRIC</b>	THIRD ANGLE PROJECTION
		mm	INCH																	
	4 PLACES	$\pm$ ---	$\pm$ ---																	
	3 PLACES	$\pm$ ---	$\pm$ ---																	
2 PLACES	$\pm 0.2$	$\pm$ ---																		
1 PLACE	$\pm$ ---	$\pm$ ---																		
DRAFT WHERE APPLICABLE MUST REMAIN WITHIN DIMENSIONS		MATERIAL NO. <b>SEE TABLE</b>	TITLE <b>CUSTOM HEADER          2.54MM PITCH SINGLE ROW          SINGLE WAFER SMT HEADER</b>	MOLEX INCORPORATED	SHEET NO. 19 OF 20															
		SIZE <b>A3</b>	THIS DRAWING CONTAINS INFORMATION THAT IS PROPRIETARY TO MOLEX INCORPORATED AND SHOULD NOT BE USED WITHOUT WRITTEN PERMISSION																	
		DOCUMENT NO. <b>SD-87898-001</b>																		

10 9 8 7 6 5 4 3 2 1

CKT	DIMENSION					
	Bo	So	Ao	Ko	F	W
7	18.20	40.40	5.20	11.30	20.20	44.00
9	23.25	40.40	5.20	11.30	20.20	44.00
11	28.35	40.40	5.20	11.30	20.20	44.00
13	33.40	52.40	5.20	11.30	26.20	56.00
15	38.50	52.40	5.20	11.30	26.20	56.00
17	43.60	68.40	5.20	11.30	34.20	72.00
19	48.70	68.40	5.20	11.30	34.20	72.00
21	53.80	68.40	5.20	11.30	34.20	72.00

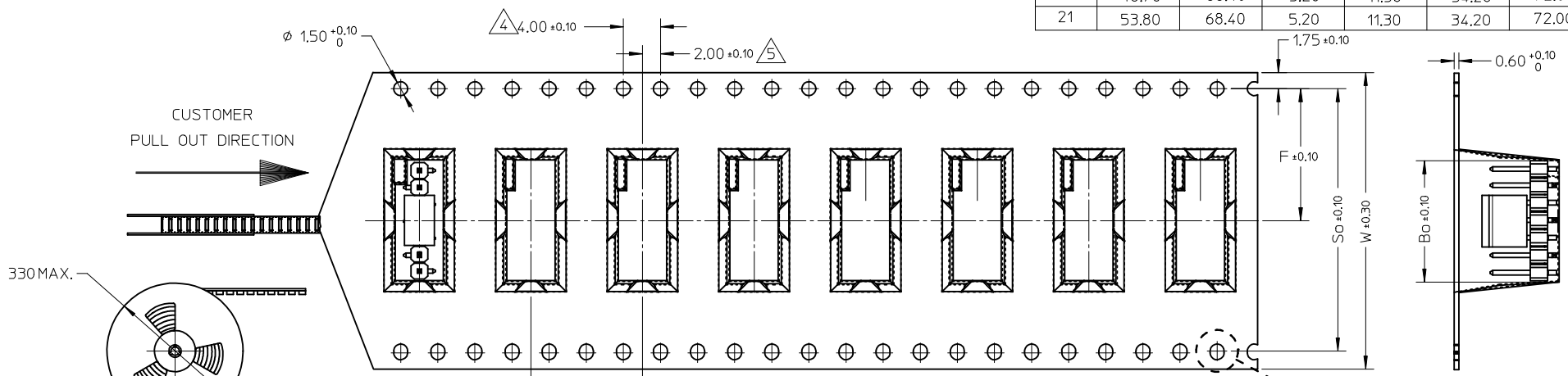

NOTES:

- LEADER AND TRAILER TAPE  
 160MIN. TOP TAPE TRAILER  
 390 MIN TOP TAPE NON BONDED TAPE  
 160MIN. TAIL PART (EMPTY)  
 230MIN. LEADER PART (EMPTY)  
 PULL OUT DIRECTION
- PEELING OFF FORCE OF THE TOP TAPE: 20 - 80gf.  
 (PEELING DIRECTION AS SHOWN IN FOLLOWING FIGURE)  
 PEEL OFF DIRECTION  
 15° MAX.

**PART PACK  
IN E/TAPE  
ORIENTATION  
(FOR REF USE)**

- MATERIAL: BLACK P.S CONDUCTIVE, BLACK MEASURED FROM CENTRELINE OF SPROCKET TO CENTRELINE OF SPOCKET
- CUMULATIVE TOLERANCE OF 10 SPROCKET HOLE IS ±0.20mm
- A0 AND B0 ARE MEASURE FROM ABOVE POCKET BASE 0.30mm
- TAPE AND REEL SPECIFICATION IS AS PER EIA-481.
- TAPE AND REEL QUANTITY : 440PCS/REEL
- THE TAPE IS TREATED FOR ANTI-STATIC.
- ALL RADII ARE 0,30MM UNLESS SPECIFY
- SURFACE RESISTIVITY 10<sup>3</sup> TO 10 OHMS.

SHT2.+87898-0315 EC NO: S2014-0976 DRWN:ATSE 2014/04/14 CHKD:FANNYWONG 2014/04/14 APPR:BLLEE 2014/09/11	QUALITY SYMBOLS F=0 E=0 E=0	GENERAL TOLERANCES (UNLESS SPECIFIED)		DIMENSION STYLE MM ONLY		SCALE NTS	DESIGN UNITS METRIC	THIRD ANGLE PROJECTION
		mm	INCH	DRAWN BY YLQIAO	DATE 2005/03/14	TITLE CUSTOM HEADER 2.54MM PITCH SINGLE ROW SINGLE WAFER SMT HEADER		
B12	DESCRIPTION REV	4 PLACES	± ---	± ---	CHECKED BY PTLIM	DATE 2005/03/29	MOLEX INCORPORATED	
		3 PLACES	± ---	± ---	APPROVED BY MLONG	DATE 2010/10/04	DOCUMENT NO. SD-87898-001	SHEET NO. 20 OF 20
DRAFT WHERE APPLICABLE MUST REMAIN WITHIN DIMENSIONS		ANGULAR ± 3 °		SEE TABLE		THIS DRAWING CONTAINS INFORMATION THAT IS PROPRIETARY TO MOLEX INCORPORATED AND SHOULD NOT BE USED WITHOUT WRITTEN PERMISSION		

9 8 7 6 5 4 3 2 1