

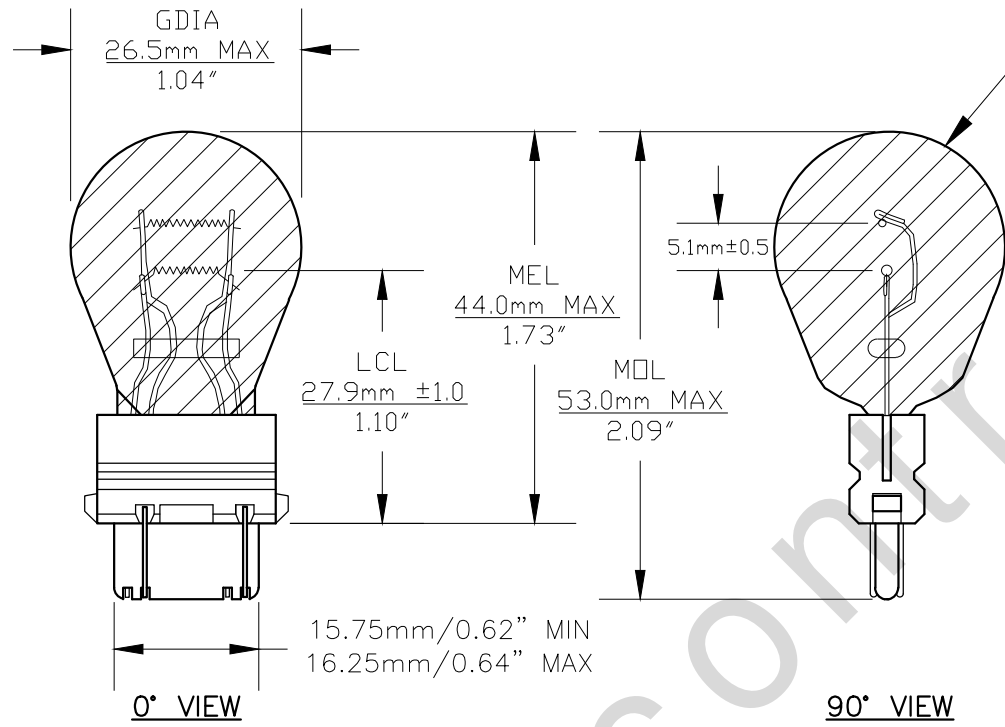

PART NO.	BASE TYPE	DESIGN VOLTS	DESIGN AMPS	MSCD	FILAMENT TYPE	AVERAGE LIFE HOURS
3457NALL	D.F. Plastic Wedge W2.5X16q	12.8V 14.0V	2.23±5% 0.59±8%	30±30% 2.2±30%	C-6 C-6	800 10000

REVISIONS			
REV #	DESCRIPTION	DATE	APPROVED
1	ISSUED	10/30/2008	D.C.
2	ADDED FILAMENT DISTANCE DIMENSIONS	10/04/2018	R.M.
3	ADDED BASE MATERIAL	03/05/2020	R.M.



S-8 BULB SHAPE
Natural Amber Glass

Plastic Base, Color: BLACK
Base Material: AMODEL

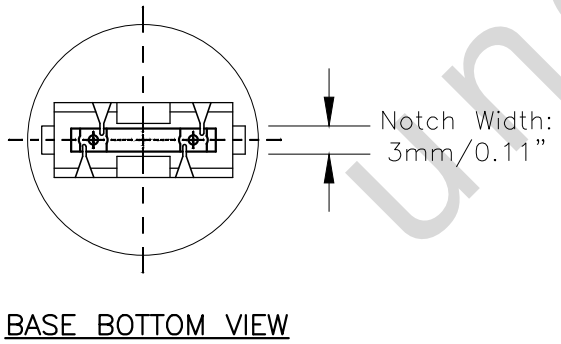
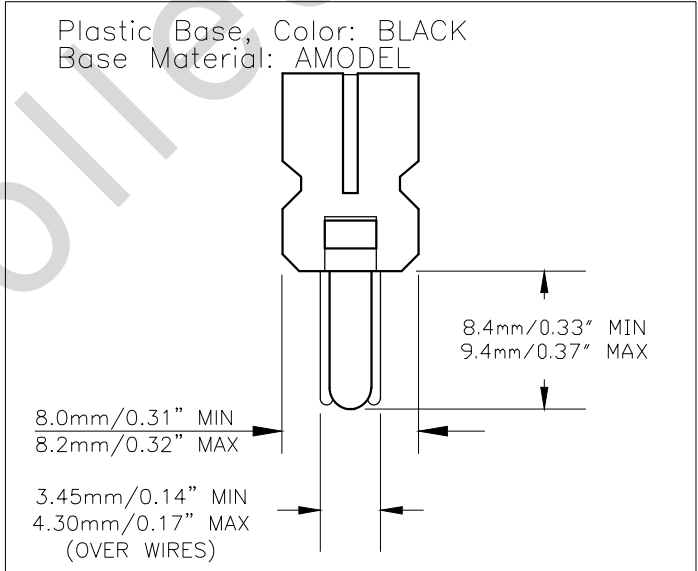

Note: Made according to SAE specifications



UNLESS OTHERWISE SPECIFIED: DIMENSIONS ARE IN INCHES TOLERANCES		CEC INDUSTRIES LTD	
DECIMALS	ANGULAR	599 BOND STREET LINCOLNSHIRE, IL 60069	
.XX ± .05	± 0.5°		
.XXX ± .010			
FRACTIONAL	± 1/64		
DRAWN D. C.	DATE 10/30/2008	TITLE LIGHT BULB NO. 3457NALL	
CHECKED	SIZE A	FSCM NO.	DWG NO. 3457NALL
DESIGN	SCALE	PLOT SCALE	REV 3
MATERIAL	FILE 3457NALL.pdf	SHEET 1 OF 1	DRAWING NOT TO SCALE