

MODEL 25SP – PROGRAMMABLE INCREMENTAL SHAFT ENCODER



FEATURES

- Industry Standard Size 25 Package (2.5" x 2.5" / 63.5 mm)
- Fully Programmable with Optional USB Module or Factory Configured
- Optical Technology for High Accuracy
- Resolutions from 1 to 65,536 CPR (262,144 quadrature counts)
- Servo and Flange Mounting
- IP67 Sealing Available

The Model 25SP Programmable Size 25 Accu-CoderPro™ shaft encoder is specifically designed for the challenges of an industrial environment. But don't let the tough exterior fool you – contained within the rugged, industrial housing is an advanced set of electronics that allow the encoder to be programmed to your exact application needs. Using EPC's optional programming module, users may select the output type, 32 different waveforms, and any resolution from 1 to 65,536 CPR – that's 262,144 counts using 4x quadrature counting. These programming features allow a single encoder to be configured for multiple applications, enabling one encoder to replace many different part numbers – and that provides cost savings on inventory and down-time replacement. The 25SP can also be configured and shipped with specs pre-programmed, with no on-site programming needed. The Model 25SP Accu-CoderPro™ comes standard with dual bearings rated 80lbs axial or radial, and may be specified with up to IP67 sealing.

COMMON APPLICATIONS

Motion Control Feedback, Conveyors, Elevator Controls, Machine Control, Food Processing, Process Control, Robotics, Material Handling, Textile Machines

Ø2.5"

MODEL 25SP ORDERING GUIDE

Blue type indicates price adder options. Not all configuration combinations may be available. Contact Customer Service for details.

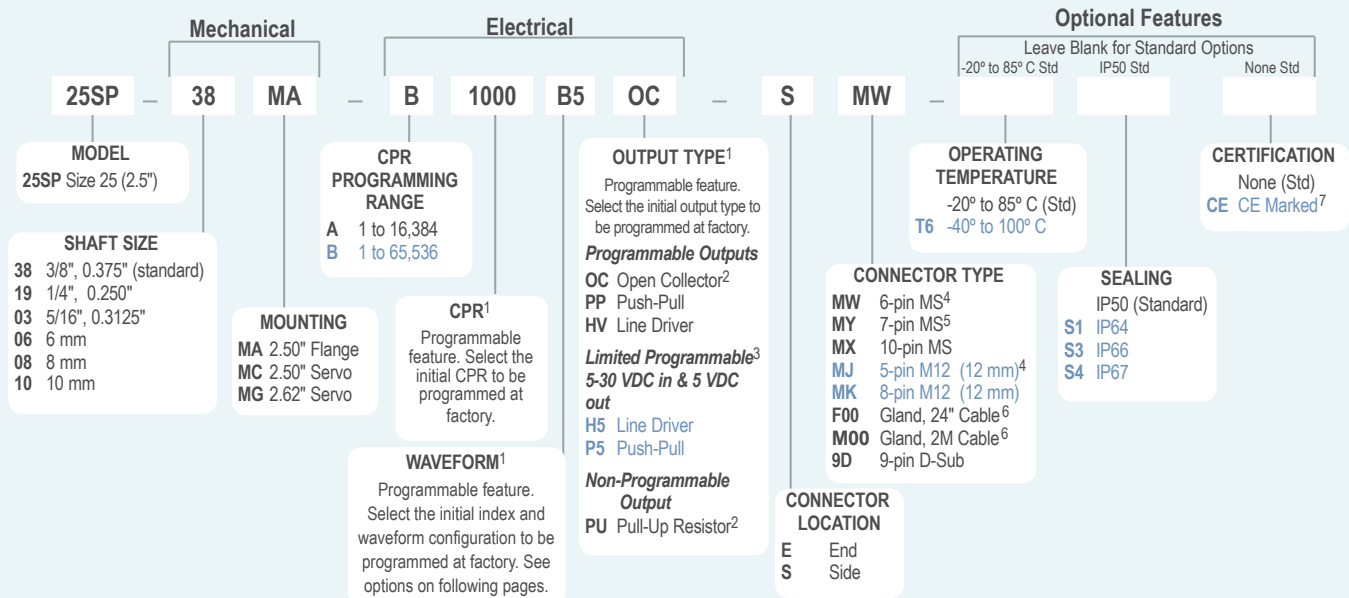

NOTES:

- 1 Programmable feature using Field Programming Software, USB Programming Module, and Interface Cable.
- 2 Open Collector (OC) and Pull-Up Resistor (PU) outputs not recommended for CPR > 8192 and/or frequencies > 150 KHz.
- 3 If ordered with initial output type of either H5 or P5, encoder cannot be programmed to OC, PP, or HV output types.
- 4 6-pin MS and 5-pin M12 Connectors only available with Pull-Up, Open Collector, and Push-Pull output types.
- 5 7-pin MS Connector does not provide Index Pulse Z when selected output is Line Driver (HV or H5).
- 6 For non-standard English cable lengths enter 'F' plus cable length expressed in feet. Example: F06 = 6 feet of cable. For non-standard metric cable lengths enter 'M' plus cable length expressed in meters. Example: M06 = 6 meters of cable. Frequency above 300 kHz standard cable lengths only.
- 7 Please refer to Technical Bulletin **TB100: When to Choose the CE Mark** at encoder.com.

ACCU-CODERPRO™
by Encoder Products Company

MODEL 25SP SPECIFICATIONS

Electrical

Input Voltage.....	4.75 to 30 VDC max. See Output Types for limitations
Input Current.....	100 mA max with no output load (65 mA typical)
Output Format.....	Incremental, Programmable. See Waveforms on following page for options.
Output Types.....	<p>Line Driver* (HV) – 20 mA max per channel, max freq 1.0 MHz, 5 VDC max at 100° C or 24 VDC max at 85° C.</p> <p>Line Driver* (H5) – 5-30 VDC in/5 VDC out, 20 mA max per channel, max freq 2.7 MHz, 5 VDC max at 100° C.</p> <p>Push-Pull (PP) – 20 mA max per channel, max frequency 1.0 MHz, 5 VDC max at 100° C or 24 VDC max at 85° C.</p> <p>Push-Pull (P5) – 5-30 VDC in/5 VDC out, 20 mA max per channel, max frequency 2.7 MHz, 5 VDC max at 100° C.</p> <p>Open Collector (OC) – 100 mA max per channel, 200 KHz max freq recommended</p> <p>Pull-Up (PU) – 2.2K ohm internal resistors, 100 mA max per channel, 150 KHz max freq recommended, max temp 85° C at > 24 VDC</p> <p>*Meets RS 422 at 5 VDC supply</p>
Index	Once per revolution, programmable. EPC standard is 180° gated to output A (waveform B5). See <i>Waveform Diagrams</i> for additional options.
Index Teach.....	Index location adjustable via programming interface.
Max Frequency	2.7 MHz subject to RPM restrictions for high resolution (CPR): 5000 RPM max for CPR 16385 to 32768 and 2500 RPM max for CPR 32769 to 65536 NOTE: Use 5 VDC Line Driver (H5 or HV output type) to obtain high frequencies.
Electrical Protection	Overvoltage, reverse voltage, and output short circuit protected. NOTE: Sustained over or reverse voltage may result in permanent damage.
Min Edge Sep	1 to 16384 CPR: 36° electrical min, 63° or better typical 16385 to 65536 CPR: 20° electrical min, 36° or better typical
Rise Time	Less than 1 microsecond
Accuracy.....	Better than 0.013° or 47 arc-sec from true position
Diagnostic	LED located on encoder housing and error report available via programming Interface.

Mechanical

Max Shaft Speed.....	8000 RPM. Higher shaft speeds may be achievable, contact Customer Service.
Shaft Material	303 Stainless Steel
Shaft Rotation	Bi-directional
Radial Shaft Load.....	80 lb max. Rated load of 20 to 40 lb for rated life of 1.5x10 ⁹ revs
Axial Shaft Load	80 lb max. Rated load of 20 to 40 lb for rated life of 1.5x10 ⁹ revs
Starting Torque	1.0 oz-in typical with IP64 seal or no seal 3.0 oz-in typical with IP66 shaft seal 7.0 oz-in typical with IP67 shaft seal
Moment of Inertia	5.6 x 10 ⁻⁴ oz-in-sec ²
Housing	Black non-corrosive finish
Bearings.....	Precision ABEC ball bearings
Weight.....	20 oz typical

Environmental

Operating Temp	-20° to 85° C for standard models -40° to 100° C for extended temp option
Humidity.....	95% RH non-condensing
Vibration.....	20 g @ 5 to 2000 Hz
Shock.....	80 g @ 11 ms duration
Sealing.....	IP50 standard; IP64, IP66 or IP67 optional

MODEL 25SP FLANGE MOUNT (MA)

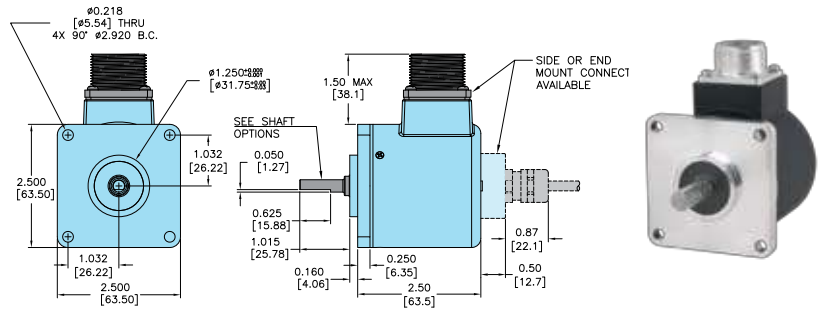

MODEL 25SP 2.5" SERVO MOUNT (MC)

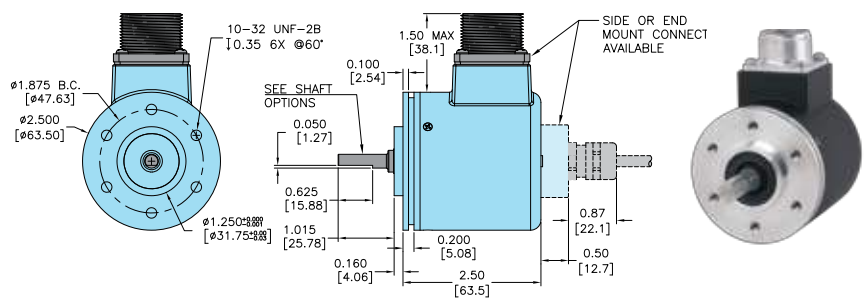

MODEL 25SP 2.62" SERVO MOUNT (MG)

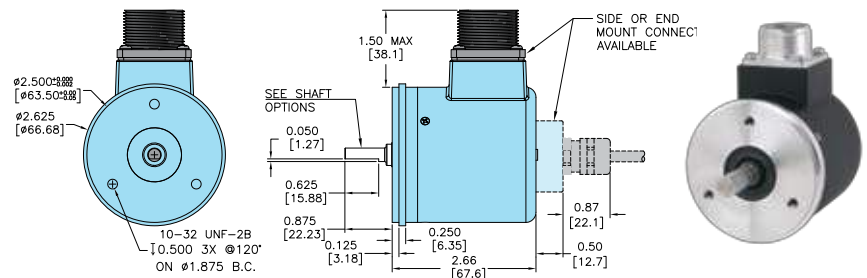

All dimensions are in inches with a tolerance of ±0.005" or ±0.01" unless otherwise specified.

ENCODER WIRING TABLE

For EPC-supplied mating cables, wiring table is provided with cable. Trim back and insulate unused wires.

Function	Gland Cable† Wire Color	5-pin M12**	8-pin M12**	10-pin MS	7-pin MS HV,H5	7-pin MS PU,PP, OC,P5	6-pin MS PU,PP, OC,P5	9-pin D-sub
Com	Black	3	7	F	F	F	A	9
+VDC	Red	1	2	D	D	D	B	1
A	White	4	1	A	A	A	D	2
A'	Brown	--	3	H	C	--	--	3
B	Blue	2	4	B	B	B	E	4
B'	Violet	--	5	I	E	--	--	5
Z	Orange	5	6	C	--	C	C	6
Z'	Yellow	--	8	J	--	--	--	7
Case	Green	--	--	G	G	G	F	8
Shield	Bare*	--	--	--	--	--	--	--

*CE Option: Cable shield (bare wire) is connected to internal case.

†Standard cable is 24 AWG conductors with foil and braid shield.

**CE Option: Use cable cordset with shield connected to M12 connector coupling nut.



An EPC Size 25 Encoder in a common application

EPC STANDARD WAVEFORM (B5)

Additional waveforms available. See below for other options.

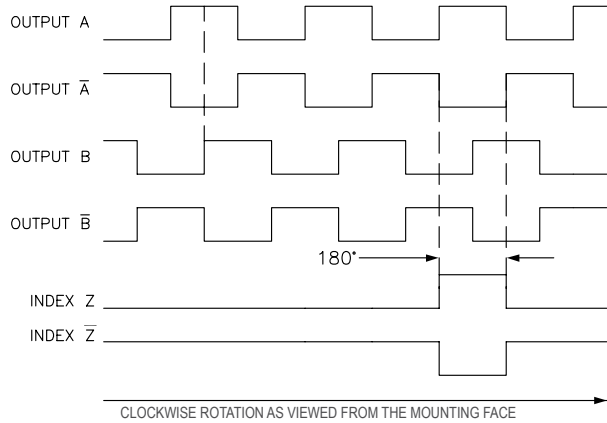

NOTE: ALL DEGREE REFERENCES ARE ELECTRICAL DEGREES.
COMPLEMENTARY SIGNALS \bar{A} , \bar{B} , \bar{Z} APPLY TO LINE DRIVER (HV & HS) OUTPUTS ONLY.

WAVEFORMS

Choose any of these waveforms when ordering. May be changed using the Field Programming Software, USB programming module, and interface cable (see following page).

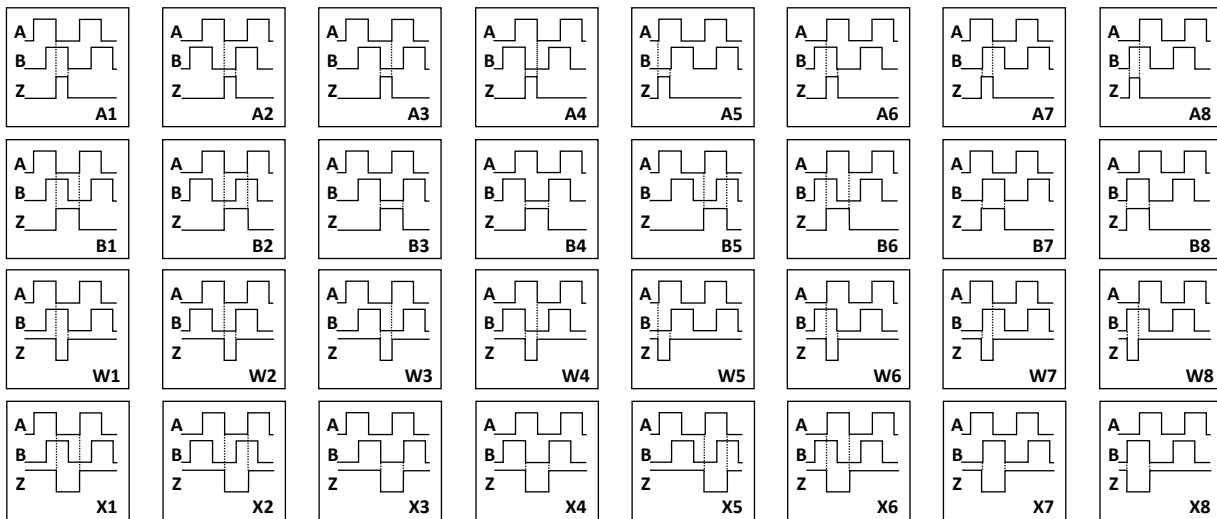

Odd numbers - A leads B
Even numbers - B leads A

A and B - High Going Index
W and X - Low Going Index

A and W - 90 Degree Index
B and X - 180 Degree Index

FIELD PROGRAMMING SOFTWARE

With the easy to use, point-and-click interface, programming is quick and straight-forward. The number of possible configurations makes this Size 25 programmable shaft encoder incredibly versatile. Anywhere a Size 25 encoder goes, the Model 25SP can get the job done.

Available on USB drive or by download.

System requirements:

- Windows 7 or higher operating systems
- USB 2.0 port required for USB Programming Module (see below)

✓ CPR – any resolution from 1 to 65,536

That's 262,144 counts using 4x quadrature counting.

✓ Waveform – choose from 32 options

See previous page for waveform choices.

✓ Output type – 6 different output types

All output types are 5V to 30V in/out except H5 Line Driver and P5 Push-Pull output types, which are 5-30VDC in and 5VDC out.



USB PROGRAMMING KIT

Kit includes Field Programming Software, USB Programming Module, and 2-meter Interface Cable with specified connector. See Accessories for individual Interface Cables.



Model 25SP assembled with programming accessories

USB Programming Module

Interface Cable

CONNECTOR TYPE	ITEM #
6-pin MS	PR1-001-06
7-pin MS	PR1-001-07
10-pin MS	PR1-001-10
5-pin M12	PR1-001-J
8-pin M12	PR1-001-K
9-pin D-Sub	PR1-001-09
Gland Cable	PR1-001-G