

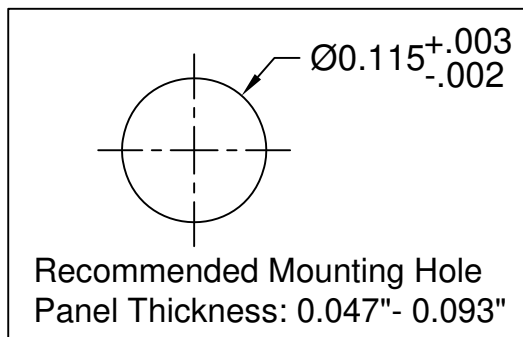

REV.	DESCRIPTION	DATE	APPROVED
T	Added Panel Thickness.	05/01/15	J. C.
U	Added .100", .188", .313" Lengths to Offering List.	05/27/15	J. C.
V	Added Metric Lengths to Offering List.	07/15/15	J. C.
W	Added Color Options, Sheet #2.	02/02/16	J. C.
Y	Updated Color Options	07/06/18	G.O.

Part No.	X = Body Length
PLP2-100	0.100 ( 2.5mm )
PLP2-125	0.125 ( 3.2mm )
PLP2-188	0.188 ( 4.8mm )
PLP2-215	0.215 ( 5.5mm )
PLP2-250	0.250 ( 6.4mm )
PLP2-313	0.313 ( 7.9mm )
PLP2-350	0.350 ( 8.9mm )
PLP2-375	0.375 ( 9.5mm )
PLP2-500	0.500 ( 12.7mm )
PLP2-625	0.625 ( 15.9mm )
PLP2-750	0.750 ( 19.0mm )
PLP2-1000	1.000 ( 25.4mm )
PLP2-1200	1.200 ( 30.5mm )
PLP2-3MM	3mm ( 0.118" )
PLP2-4MM	4mm ( 0.157" )
PLP2-5MM	5mm ( 0.197" )
PLP2-6MM	6mm ( 0.236" )
PLP2-7MM	7mm ( 0.276" )
PLP2-8MM	8mm ( 0.315" )
PLP2-9MM	9mm ( 0.354" )
PLP2-10MM	10mm ( 0.394" )

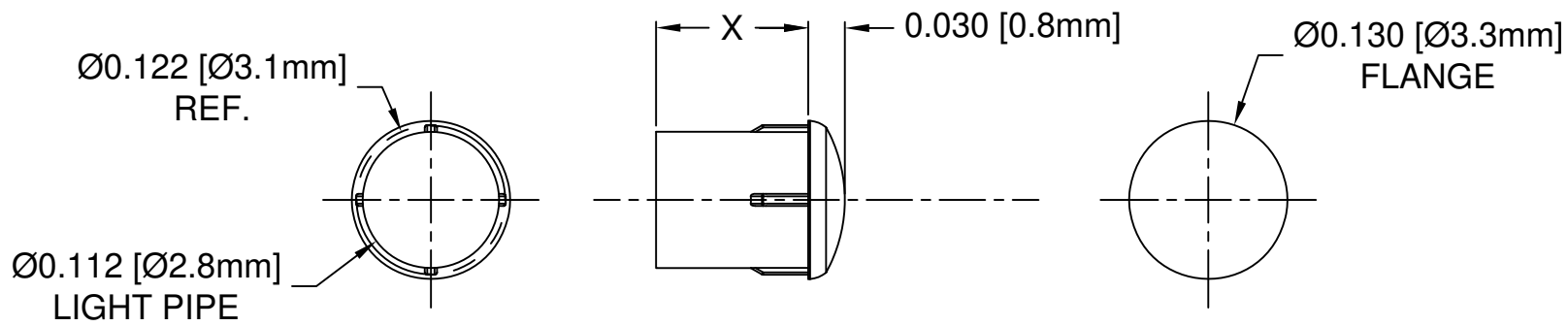

2. MATERIAL: POLYCARBONATE, 94V-0, CLEAR.

1. GENERAL SPECIFICATIONS: BIVAR MOLDED COMPONENT SPECIFICATION BV00-E101 and BSMC-1001.

STANDARD TOLERANCE (UNLESS OTHERWISE SPECIFIED)		 <b>BIVAR</b> <sup>®</sup> 4 THOMAS, IRVINE, CA. 92618 TEL: (949) 951-8808 FAX: (949) 951-3974	
DECIMALS	ANGULAR		
.X ± .1 .XX ± .01 .XXX ± .005	X° ± 1°		
DESIGNED: M. CHEN	DATE: 01/16/02	TITLE: PRESS-FIT, PANEL MOUNT, LIGHT PIPE, FRONT MOUNT	REVISION: Y
REVISOR: K. BARON	DATE: 07/06/18	PART NO: PLP2-XXX	CAGE CODE: 32559
CHECKED: TD. NGUYEN	DATE: 07/06/18	SCALE: 1:1	SHEET # 1 OF 2
CAD GENERATED DOCUMENT, DO NOT MEASURE DRAWING			

OTHER AVAILABLE COLORS  
 \* SEE TABLE FOR ORDERING INFORMATION

REV.	DESCRIPTION	DATE	APPROVED
	SEE SHEET #1		

## AVAILABLE COLOR OPTIONS

PLP2 -      -

RIGID LIGHT PIPE  
SERIES

LENGTH

PART NUMBER	BODY LENGTH
PLP2-100	0.100" (2.5mm)
PLP2-125	0.125" (3.2mm)
PLP2-2.5mm	2.5mm (0.100")
PLP2-3mm	3mm (0.118")

COLOR	Order Code
TINTED BLUE	BE
TINTED GREEN	GN
TINTED RED	RD
TINTED YELLOW	YW

PLP2 -      -

RIGID LIGHT PIPE  
SERIES

LENGTH

PART NUMBER	BODY LENGTH
PLP2-100	0.100" (2.5mm)
PLP2-125	0.125" (3.2mm)
PLP2-2.5mm	2.5mm (0.100")
PLP2-3mm	3mm (0.118")

COLOR	Order Code
DIFFUSED	D
SMOKED	S

**BIVAR**<sup>®</sup>

PART NO: PLP2-XXX	REVISION: Y
----------------------	----------------

SCALE: NONE	SHEET # 2 OF 2
-------------	----------------

CAD GENERATED DOCUMENT. DO NOT MEASURE DRAWING