



LB1947

Monolithic Digital IC PWM Current Control Type Bidirectional Motor Driver

Overview

The LB1947 is a PWM current control type bidirectional motor driver IC.

Features

- PWM current control (fixed OFF time)
- Selectable current decay pattern (FAST, SLOW, and MIX DECAY modes)
- Simultaneous ON prevention function (feed-through current prevention)
- Built-in thermal shutdown circuit
- Built-in noise canceler

Specifications

Absolute Maximum Ratings at $T_a = 25^\circ\text{C}$

Parameter	Symbol	Conditions	Ratings	Unit
Maximum motor supply voltage	V_{BB} max		50	V
Output peak current	I_O peak	$t_w \leq 20\mu\text{s}$	2.25	A
Output continuous current	I_O max		2.0	A
Logic supply voltage	V_{CC} max		7.0	V
Logic input voltage range	V_{IN}		-0.3 to V_{CC}	V
Emitter output voltage	V_E max		1.1	V
Reference voltage	V_{REF}		-0.3 to V_{CC}	V
Allowable power dissipation	P_d max		1.6	W
Operating temperature	T_{opr}		-20 to +85	$^\circ\text{C}$
Storage temperature	T_{stg}		-55 to +150	$^\circ\text{C}$

■ Any and all SANYO Semiconductor Co.,Ltd. products described or contained herein are, with regard to "standard application", intended for the use as general electronics equipment (home appliances, AV equipment, communication device, office equipment, industrial equipment etc.). The products mentioned herein shall not be intended for use for any "special application" (medical equipment whose purpose is to sustain life, aerospace instrument, nuclear control device, burning appliances, transportation machine, traffic signal system, safety equipment etc.) that shall require extremely high level of reliability and can directly threaten human lives in case of failure or malfunction of the product or may cause harm to human bodies, nor shall they grant any guarantee thereof. If you should intend to use our products for applications outside the standard applications of our customer who is considering such use and/or outside the scope of our intended standard applications, please consult with us prior to the intended use. If there is no consultation or inquiry before the intended use, our customer shall be solely responsible for the use.

■ Specifications of any and all SANYO Semiconductor Co.,Ltd. products described or contained herein stipulate the performance, characteristics, and functions of the described products in the independent state, and are not guarantees of the performance, characteristics, and functions of the described products as mounted in the customer's products or equipment. To verify symptoms and states that cannot be evaluated in an independent device, the customer should always evaluate and test devices mounted in the customer's products or equipment.

LB1947

Allowable Operating Ranges at $T_a = 25^\circ\text{C}$

Parameter	Symbol	Conditions	Ratings	Unit
Motor supply voltage	V_{BB}		10 to 45	V
Logic supply voltage	V_{CC}		4.75 to 5.25	V
Reference voltage	V_{REF}		0 to $V_{CC}-2$	V

Electrical Characteristics at $T_a = 25^\circ\text{C}$, $V_{CC} = 5\text{V}$

Parameter	Symbol	Conditions	Ratings			Unit
			min	typ	max	
Output Block						
Output stage supply current	$I_{BB\ ON}$	No-load state, Forward	0.4	0.6	1.0	mA
	$I_{BB\ BR}$	No-load state, Brake	0.2	0.4	0.8	mA
	$I_{BB\ OFF}$	No-load state, Output off	0.2	0.4	0.8	mA
	$I_{BB\ wt}$	No-load state, Standby mode			0.1	mA
Output saturation voltage	$V_{O\ sat1}$	$I_O = +1.0\text{A}$, Sink		1.2	1.5	V
	$V_{O\ sat2}$	$I_O = +2.0\text{A}$, Sink		1.6	1.9	V
	$V_{O\ sat3}$	$I_O = -1.0\text{A}$, Source		1.8	2.2	V
	$V_{O\ sat4}$	$I_O = -2.0\text{A}$, Source		2.1	2.4	V
Output leak current	$I_{O1(leak)}$	$V_O = V_{BB}$, Sink			50	μA
	$I_{O2(leak)}$	$V_O = 0\text{V}$, Source	-50			μA
Output sustain voltage	V_{SUS}	$L = 3.9\text{mH}$, $I_O = 2.0\text{A}$, Design guarantee value*	50			V
Logic Block						
Logic supply current	$I_{CC\ ON}$	IN1: High, IN2: Low, ST: High	11	16	21	mA
	$I_{CC\ BR}$	IN1: Low, IN2: High, ST: High	11	16	21	mA
	$I_{CC\ OFF}$	IN1: Low, IN2: Low, ST: High	11	16	21	mA
	$I_{CC\ wt}$	ST: Low	1.0	2	3.0	mA
Input voltage	$V_{IN\ H}$		2			V
	$V_{IN\ L}$				0.8	V
Input current	$I_{IN\ H}$	$V_{IN} = 5\text{V}$	60	90	120	μA
	$I_{IN\ L}$	$V_{IN} = 0.8\text{V}$	6	10	13	μA
Sensing voltage	V_E		0		1.1	V
Sensing voltage 25H	V_{EH25}	$V_I = \text{High}$, $V_{REF} = 2.5\text{V}$	0.970	1.0	1.030	V
Sensing voltage 25L	V_{EL25}	$V_I = \text{Low}$, $V_{REF} = 2.5\text{V}$	0.483	0.5	0.513	V
Sensing voltage 15H	V_{EH15}	$V_I = \text{High}$, $V_{REF} = 1.5\text{V}$	0.385	0.4	0.410	V
Sensing voltage 15L	V_{EL15}	$V_I = \text{Low}$, $V_{REF} = 1.5\text{V}$	0.190	0.2	0.210	V
Sensing voltage 05H	V_{EH05}	$V_I = \text{High}$, $V_{REF} = 0.5\text{V}$	0.190	0.2	0.210	V
Sensing voltage 05L	V_{EL05}	$V_I = \text{Low}$, $V_{REF} = 0.5\text{V}$	0.092	0.1	0.108	V
Reference current	I_{ref}	$V_{REF} = 1.0\text{V}$	-0.5		+0.5	μA
CR pin current	I_{CR}		-1.56	-1.3	-1.04	mA
MD pin voltage	$V_{MD\ H}$		$V_{CC}-0.3$			V
	$V_{MD\ M}$		$0.3V_{CC}$		$V_{CC}-1.0$	V
	$V_{MD\ L}$.04	V
MD input current	$I_{MD\ H}$	$MD = V_{CC}-0.5\text{V}$, $CR = 1.0\text{V}$	-1.0		+1.0	μA
	$I_{MD\ L}$	$MD = 0.4\text{V}$, $CR = 2.0\text{V}$	-5.0			μA
Thermal shutdown temperature	TSD	Design guarantee value*		170		$^\circ\text{C}$

* Design guarantee value, Do not measurement.

LB1947

Package Dimensions

unit : mm (typ)
3249

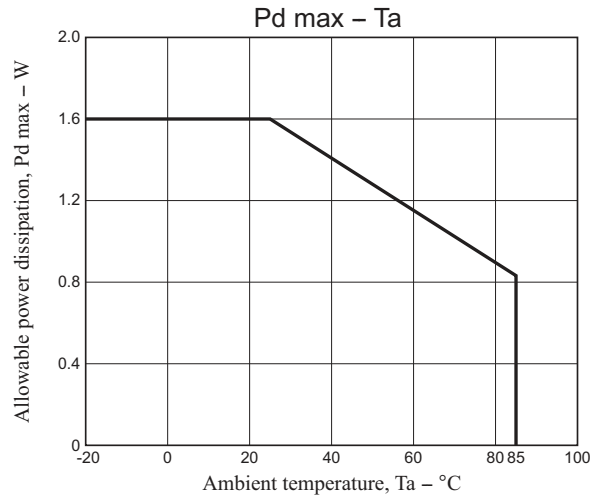
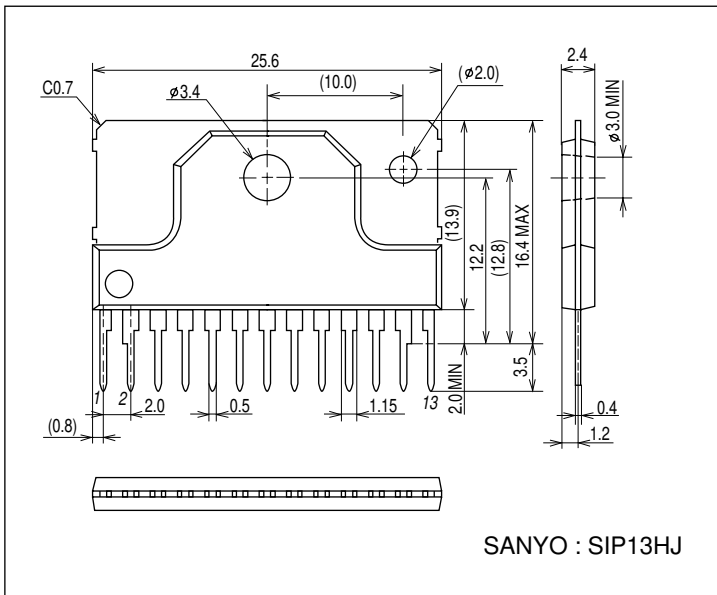

Pin Assignment

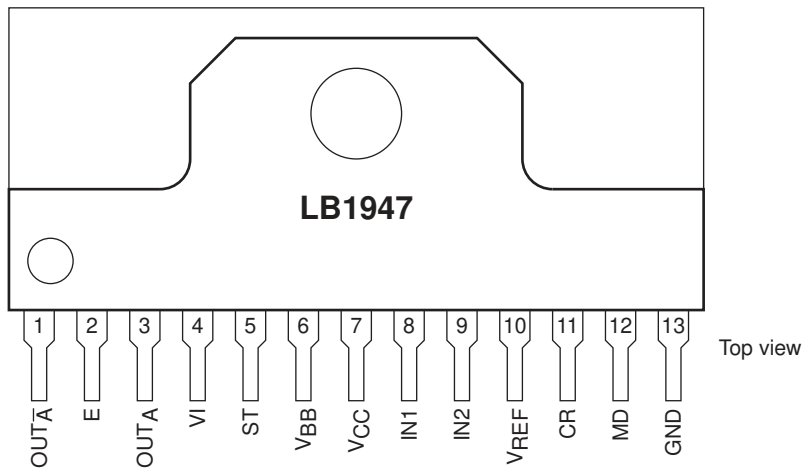

Block Diagram

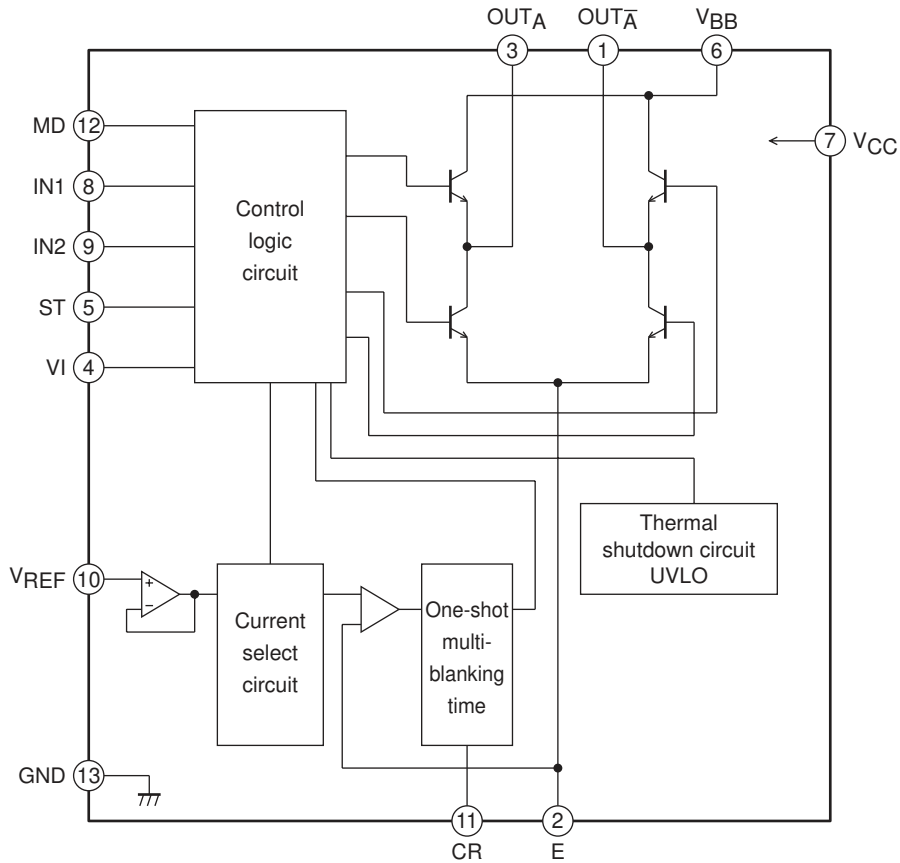

Truth Table

IN1	IN2	ST	VI	MD	OUT _A	OUT _A [̄]	Operating mode
H	L	H	H	L	H	L	Forward, 2/5 times, FAST
H	L	H	H	M	H	L	Forward, 2/5 times, MIX
H	L	H	H	H	H	L	Forward, 2/5 times, SLOW
H	L	H	L	L	H	L	Forward, 1/5 times, FAST
H	L	H	L	M	H	L	Forward, 1/5 times, MIX
H	L	H	L	H	H	L	Forward, 1/5 times, SLOW
H	H	H	H	L	L	H	Reverse, 2/5 times, FAST
H	H	H	H	M	L	H	Reverse, 2/5 times, MIX
H	H	H	H	H	L	H	Reverse, 2/5 times, SLOW
H	H	H	L	L	L	H	Reverse, 1/5 times, FAST
H	H	H	L	M	L	H	Reverse, 1/5 times, MIX
H	H	H	L	H	L	H	Reverse, 1/5 times, SLOW
L	H	H	H	L	L	L	Brake, 2/5 times, FAST
L	H	H	H	M	L	L	Brake, 2/5 times, MIX
L	H	H	L	L	L	L	Brake, 1/5 times, FAST
L	H	H	L	M	L	L	Brake, 1/5 times, MIX
L	H	H	X	H	L	L	Brake, no current limiting
L	L	H	X	X	OFF	OFF	Output OFF
X	X	L or OPEN	X	X	OFF	OFF	Standby mode (circuit OFF)

Except for MD pin, Low at input OPEN.

MD M: determined by external voltage.

LB1947

Pin Function

Pin No.	Pin name	Function	Equivalent circuit
1 3	OUT _A OUT _A	Output pin.	
2	E	Sense voltage control pin.	
4	VI	High: sense voltage is 2/5 of V _{REF} Low: sense voltage is 1/5 of V _{REF}	
5	ST	High: circuit operation ON Low: standby mode	
8	IN1	High: rotation mode Low: brake mode	
9	IN2	High: reverse mode Low: forward mode	
6	V _{BB}	Motor power supply voltage.	
7	V _{CC}	Logic power supply voltage.	
10	V _{REF}	Output current setting reference pin. Setting range: 0 to (V _{CC} -2V)	
11	CR	Oscillator with self-excitation.	
12	MD	Current attenuation switching pin. Low : FAST DECAY High: SLOW DECAY M : MIX DECAY M is set by external power supply voltage. Range : 1.1 to 4.0V	
13	GND	Ground pin	

Sample Application Circuits

1. Forward/reverse motor with current limiter

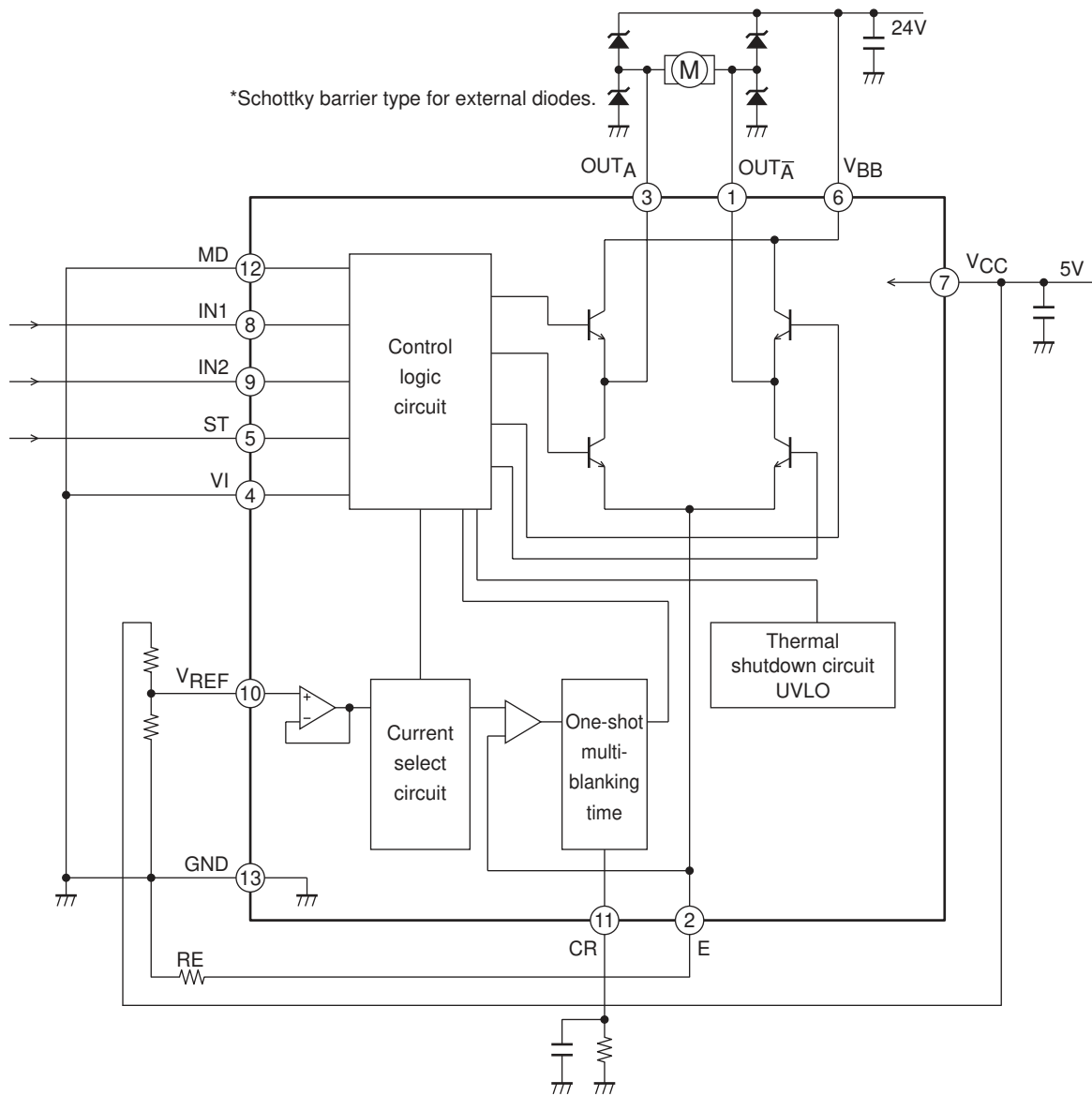

Limiter current setting method

$$I = V_{REF} / (5 \times RE)$$

IN1	IN2	ST	OUT _A	OUT _A [̄]	Mode
H	L	H	H	L	Forward
H	H	H	L	H	Reverse
L	H	H	L	L	Brake
L	L	H	OFF	OFF	Output OFF
-	-	L	OFF	OFF	Standby mode

LB1947

2. Forward/reverse motor

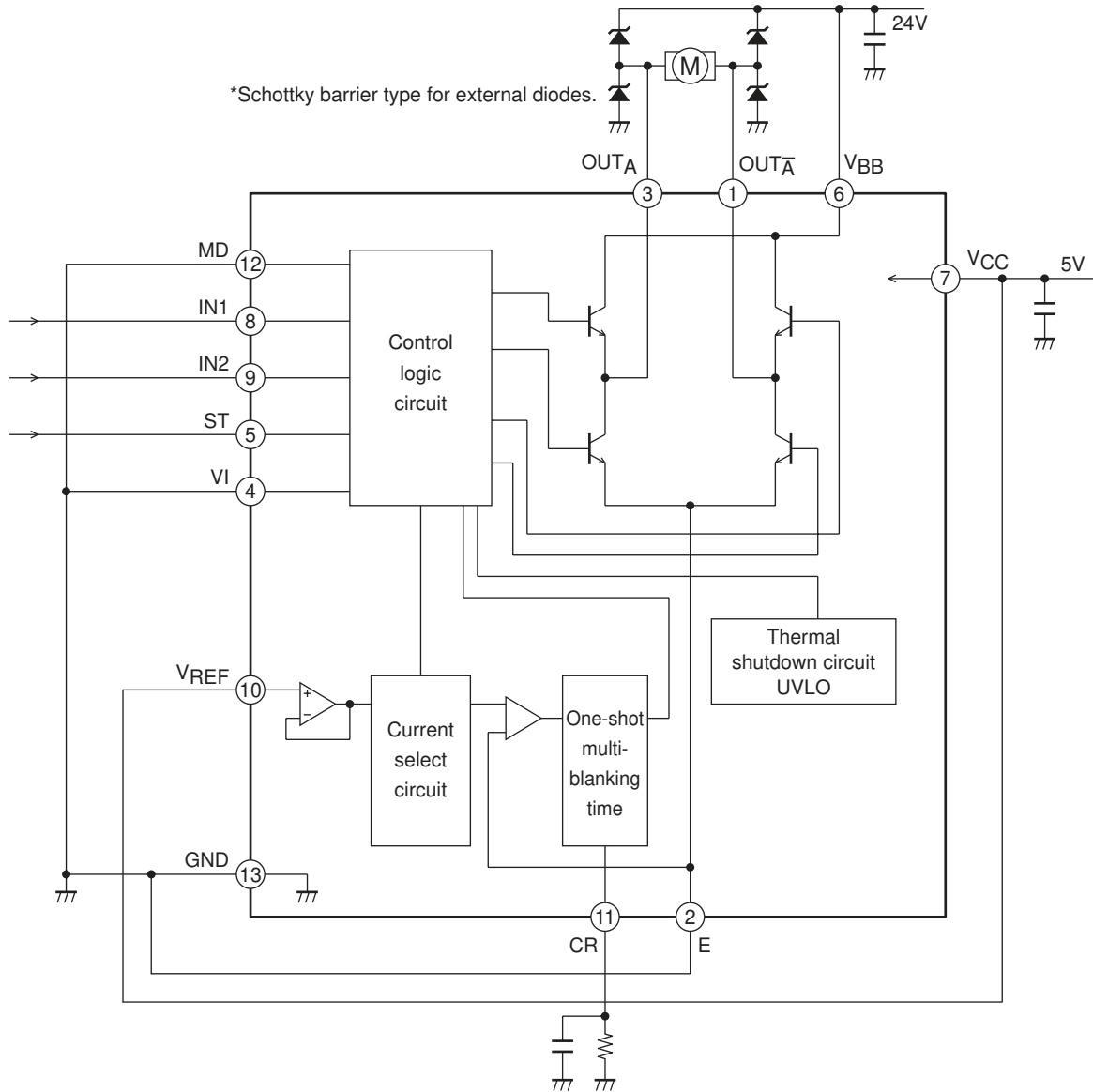

IN1	IN2	ST	OUT _A	OUT _A [̄]	Mode
H	L	H	H	L	Forward
H	H	H	L	H	Reverse
L	H	H	L	L	Brake
L	L	H	OFF	OFF	Output OFF
-	-	L	OFF	OFF	Standby mode

LB1947

3. PWM current control forward/reverse motor (MIX DECAAY)

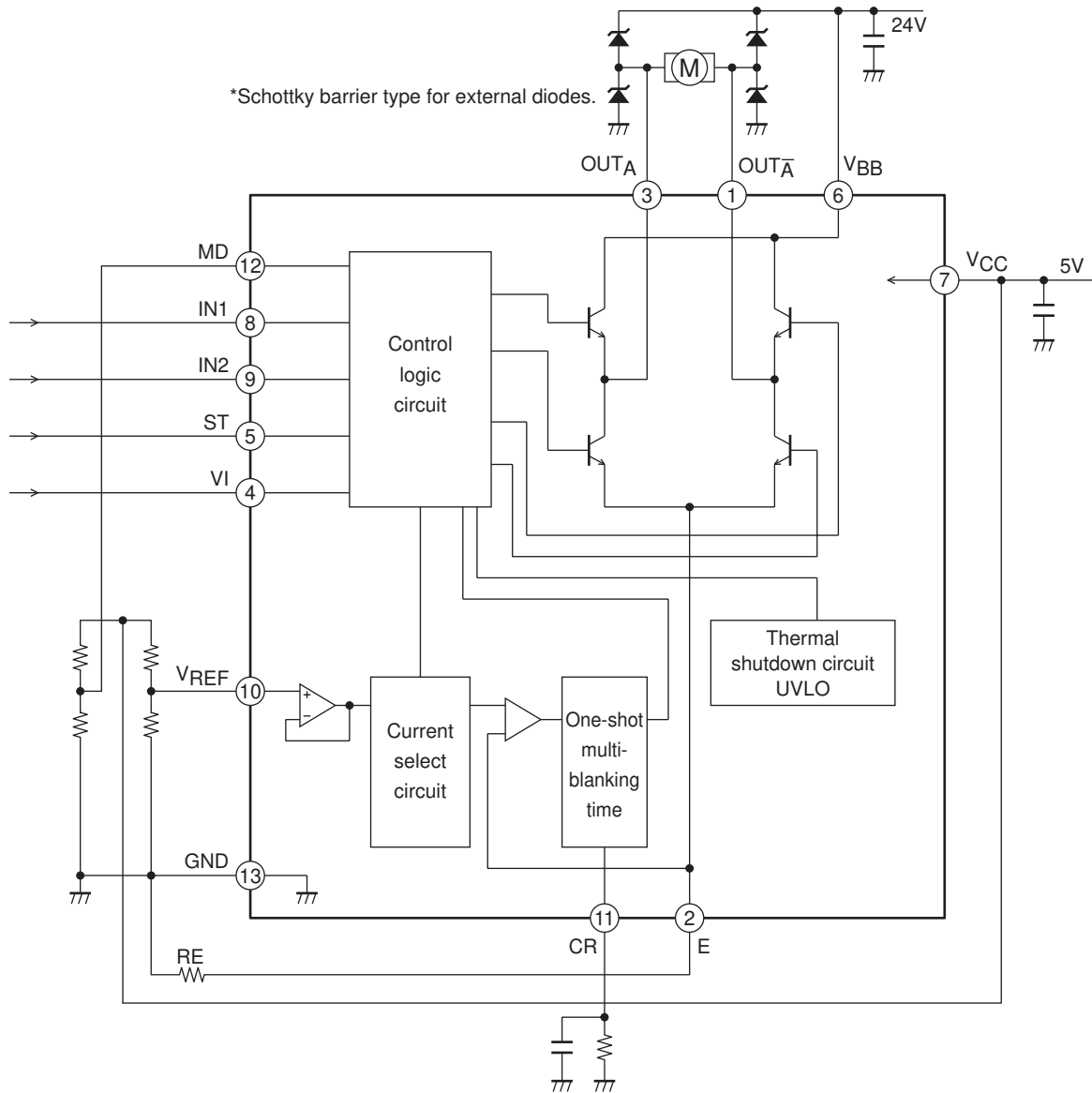

Notes on Usage

1. VREF pin

Because the VREF pin serves for input of the set current reference voltage, precautions against noise must be taken.

2. GND pin

The ground circuit for this IC must be designed so as to allow for high-current switching. Blocks where high current flows must use low-impedance patterns and must be removed from small-signal lines. Especially the ground connection for the sensing resistor RE at pin E, and the ground connection for the Schottky barrier diodes should be in close proximity to the IC ground.

The capacitors between VCC and ground, and VBB and ground should be placed close to the VCC and VBB pins, respectively.

3. CR pin setting (Switching off time, Noise cancel time)

The noise cancel time (Tn) and the switching off time (Toff) are set by the following expressions:

Noise cancel time: $T_n \approx C \times R \times \ln \{ (1.0 - RI) / (4.0 - RI) \}$ [sec]

CR charge current: 1.3mA

Switching off time: $T_{off} \approx -C \times R \times \ln (1.0 / 4.8)$ [sec]

Internal configuration at CR pin

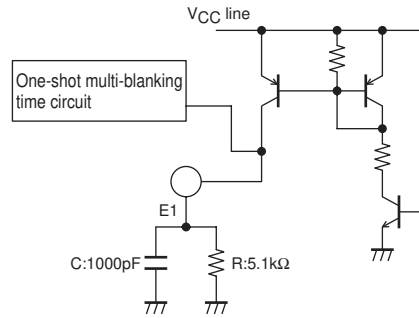

CR constant range: R = 4.7k to 100kΩ

C = 330pF to 2200pF

- SANYO Semiconductor Co.,Ltd. assumes no responsibility for equipment failures that result from using products at values that exceed, even momentarily, rated values (such as maximum ratings, operating condition ranges, or other parameters) listed in products specifications of any and all SANYO Semiconductor Co.,Ltd. products described or contained herein.
- SANYO Semiconductor Co.,Ltd. strives to supply high-quality high-reliability products, however, any and all semiconductor products fail or malfunction with some probability. It is possible that these probabilistic failures or malfunction could give rise to accidents or events that could endanger human lives, trouble that could give rise to smoke or fire, or accidents that could cause damage to other property. When designing equipment, adopt safety measures so that these kinds of accidents or events cannot occur. Such measures include but are not limited to protective circuits and error prevention circuits for safe design, redundant design, and structural design.
- In the event that any or all SANYO Semiconductor Co.,Ltd. products described or contained herein are controlled under any of applicable local export control laws and regulations, such products may require the export license from the authorities concerned in accordance with the above law.
- No part of this publication may be reproduced or transmitted in any form or by any means, electronic or mechanical, including photocopying and recording, or any information storage or retrieval system, or otherwise, without the prior written consent of SANYO Semiconductor Co.,Ltd.
- Any and all information described or contained herein are subject to change without notice due to product/technology improvement, etc. When designing equipment, refer to the "Delivery Specification" for the SANYO Semiconductor Co.,Ltd. product that you intend to use.
- Information (including circuit diagrams and circuit parameters) herein is for example only; it is not guaranteed for volume production.
- Upon using the technical information or products described herein, neither warranty nor license shall be granted with regard to intellectual property rights or any other rights of SANYO Semiconductor Co.,Ltd. or any third party. SANYO Semiconductor Co.,Ltd. shall not be liable for any claim or suits with regard to a third party's intellectual property rights which has resulted from the use of the technical information and products mentioned above.

This catalog provides information as of February, 2009. Specifications and information herein are subject to change without notice.