

PART NUMBER	REVISION	DESCRIPTION	FEED TYPE
2151434-2	G	FINE CRIMP HEIGHT ADJUST	PNEUMATIC
7-2151434-2	G	PNEUMATIC AND CRIMP TOOLING KIT	PNEUMATIC
7-2151434-7	A	CRIMP TOOLING KIT	-

ATLANTIC VERSION TERMINATOR INTERFACE ADAPTER

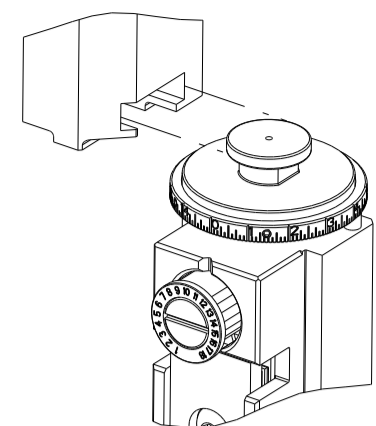

APPLICATOR DATA		
CRIMP	SIZE	TYPE
WIRE	1.37 mm [.054]	F
INSUL	1.96 mm [.077]	F

APPLICATOR INSTRUCTIONS 408-35042

TERMINAL DATA: MOLEX TERMINAL MOLEX CRIMP SPECIFICATION			
TERMINAL NAME: KK CRIMP TERMINAL			
WIRE STRIP LENGTH	INSULATION DIAMETER RANGE		
2.54-3.18 mm [.100-.125 IN]	Ø1.09-1.57 mm [.043-.062 IN]		
TERMINAL APPLICATION SPECIFICATION			
TERMINALS APPLIED			
TE TERMINAL	MOLEX TERMINAL	TE TERMINAL	MOLEX TERMINAL
286698-1	08-50-0113	286698-2	08-55-0101
286698-3	08-56-0109		

TERMINAL DATA: MOLEX TERMINAL MOLEX CRIMP SPECIFICATION			
TERMINAL NAME: KK CRIMP TERMINAL			
WIRE STRIP LENGTH	INSULATION DIAMETER RANGE		
2.54-3.18 mm [.100-.125 IN]	Ø1.09-1.57 mm [.043-.062 IN]		
TERMINAL APPLICATION SPECIFICATION			
TERMINALS APPLIED			
TE TERMINAL	MOLEX TERMINAL	TE TERMINAL	MOLEX TERMINAL
286698-4	08-52-0101	286698-5	08-65-0815
286698-6	08-65-0813	286698-7	97-00-0444
286698-8	08-55-0102	286698-9	08-70-0046
1-286698-0	08-52-0118	1-286698-1	08-52-0121
1-286698-2	08-50-0321	1-286698-3	08-65-0804
1-286698-4	08-65-0801	1-286698-5	08-65-0811
1-286698-6	08-65-0817	1-286698-7	40-07-0815
1-286698-8	97-00-0920		

TERMINAL DATA: MOLEX TERMINAL MOLEX CRIMP SPECIFICATION			
TERMINAL NAME: KK CRIMP TERMINAL			
WIRE STRIP LENGTH	INSULATION DIAMETER RANGE		
2.54-3.18 mm [.100-.125 IN]	Ø1.20-1.70 mm [.047-.067 IN]		
TERMINAL APPLICATION SPECIFICATION			
TERMINALS APPLIED			
TE TERMINAL	MOLEX TERMINAL	TE TERMINAL	MOLEX TERMINAL
1949741-1	08-70-0048	1949741-2	08-70-0064

WIRE SIZE	CRIMP HEIGHT mm [INCH]	CRIMP HEIGHT REFERENCE SETTING
22 AWG	0.815+/-0.025 [.032+/- .001]	6.2
24 AWG	0.760+/-0.030 [.030+/- .001]	6.4
26 AWG	0.735+/-0.025 [.029+/- .001]	6.6
28 AWG	0.705+/-0.025 [.028+/- .001]	6.8
30 AWG	0.685+/-0.025 [.027+/- .001]	7.0

WIRE SIZE	CRIMP HEIGHT mm [INCH]	CRIMP HEIGHT REFERENCE SETTING
22 AWG	0.815+/-0.025 [.032+/- .001]	6.2
24 AWG	0.765+/-0.025 [.030+/- .001]	6.4
26 AWG	0.710+/-0.030 [.028+/- .001]	6.6
28 AWG	0.685+/-0.025 [.027+/- .001]	6.8
30 AWG	0.645+/-0.015 [.0265+/- .0005]	7.0

WIRE SIZE	CRIMP HEIGHT mm [INCH]	CRIMP HEIGHT REFERENCE SETTING
22 AWG	0.815+/-0.025 [.032+/- .001]	6.2
24 AWG	0.765+/-0.025 [.030+/- .001]	6.4
26 AWG	0.710+/-0.030 [.028+/- .001]	6.6
28 AWG	0.685+/-0.025 [.027+/- .001]	6.8

LOC	DIST	REVISIONS					
		P	LTN	DESCRIPTION	DATE	OWN	APPD
A	66	D1		ECR-19-000561	14JAN2019	MZ	YY
		E		ECR-19-009011	08JUN2019	TB	TE
		F		ECR-22-148341	03AUG2022	TB	GB
		G		ECR-23-180161	04JUL2023	FZ	JAH

-	1	1	23238-1	INSERT, COUPLING	278
-	1	1	2030758-3	TUBING, POLYURETHANE	277
-	1	1	5018030-2	NUT, HEX, REG, RoHS, M4	276
-	1	1	986220-3	CLAMP, CABLE, BLACK	275
-	1	1	1-2168083-0	SCR, SKT HD CAP, RoHS, M4 X 10	274
-	1	1	2217068-1	BRACKET, AIR BLAST	273
-	1	1	2119641-1	FEED CAM, AIR FEED	248
-	1	1	2119082-5	CAM, SNAIL, INSULATION ADJUSTMENT	244
-	1	1	2079764-1	WASHER, WAVE SPRING, CREST-TO-CREST	243
-	1	1	2119083-1	RETAINER, INSULATION DIAL	242
-	1	1	2844940-1	AIR FEED MODULE	238
-	1	1	2391993-1	PLATE, REAR SHEAR	233
-	1	1	1803174-3	BLADE, SLUG	232
-	REF	REF	994970-2	COUNTER, MAGNETIC	164
-	2	2	2031943-1	SPACER, CRIMPER, SPECIAL	156
-	1	1	1-22281-8	SPRING, COMPRESSION	121
-	1	1	2119955-1	ASSY, LUBRICATOR, SIDE FEED	113
-	1	1	2844908-1	SCREW, LOCKING	99
-	1	1	2844907-1	POST, LOCKING	98
-	1	1	2-690487-2	GUIDE, FRONT STRIP	96
-	2	2	2168083-1	SCR, SKT HD CAP, RoHS, M3 X 8.0	95
-	1	1	2168083-6	SCR, SKT HD CAP, RoHS, M5 X 6.5	93
-	1	1	2168083-8	SCR, SKT HD CAP, RoHS, M4 X 16	88
-	1	1	455888-7	SPACER, CRIMPER	82
-	1	1	1803607-3	DOCUMENTATION PACKAGE	71
-	1	1	2119791-9	DEPRESSOR, WIRE	70
-	1	1	2119740-1	TAG, IDENTIFICATION	67
-	2	2	2168078-1	SCREW, DRIVE, RH, RoHS, 2 x .188	66
-	2	2	2-18032-5	SCR, SET, FLT PNT, M5 X 20.0	61
-	1	1	2168083-2	SCR, SKT HD CAP, RoHS, M4 X 8.0	60
-	1	1	5-18022-5	SCR, HEX HD CAP, M4 X 6.0	59
-	1	1	1338685-1	PAWL, FEED	56
-	1	1	18023-9	SCR, SKT HD CAP M4 X 6.0	49
-	1	1	1803583-9	APPLICATOR BASIC ASSEMBLY, SF	46
-	1	1	1803515-1	RAM ASSEMBLY, SF ATLANTIC	44
-	1	1	1803602-1	SCR, BHSC, RoHS (M8 X 25)	41
-	2	2	2079383-5	SCR, BHSC, RoHS (M4 X 20)	33
-	2	2	1-2844962-3	SPACER, CYLINDRICAL, STRIP GUIDE	30
-	1	1	2-2844938-9	PLATE, STRIP GUIDE	29
-	2	2	22280-1	SPRING, COMPRESSION	27
-	1	1	356835-1	LEVER, DRAG RELEASE	26
-	1	1	1-690754-5	DRAG, SPECIAL	25
-	1	1	1320928-2	STRIP GUIDE	24
-	1	1	980371-4	SCR, SKT HD SHLDR 5.0 DIA X 6.0	23
-	1	1	2168083-2	SCR, SKT HD CAP, RoHS, M4 X 8.0	21
-	4	4	1-18028-2	WASHER, FLAT, REG M4	20
-	1	1	1-2119533-1	STRIPPER, SIDE FEED	19
-	-	-	-	-	10
-	-	-	-	-	9
-	-	-	-	-	7
-	-	-	-	-	6
-	-	-	-	-	5
-	1	1	1803409-8	BLOCK, CRIMPER SPACER	4
-	1	2	1-3-1803017-6	CRIMPER, INSULATION F	3
-	-	-	-	-	2
-	1	2	1-1803173-1	CRIMPER, WIRE	1

- RECOMMENDED SPARE PARTS
- REFER TO SUPPLIED INSTRUCTION SHEET FOR CLEANING, LUBRICATION AND STORAGE OF APPLICATOR.
- APPLY PART NUMBER 2-23419-6 LOCTITE TO THREADS OF ITEM 242.
- CRIMP HEIGHT REFERENCE SETTING WAS THE SETTING USED WHEN THE APPLICATOR WAS QUALIFIED AT THE FACTORY. ADJUSTMENT MAY BE NECESSARY WHEN RUNNING APPLICATOR IN THE FIELD.
- TERMINAL PITCH NOT COMPATIBLE WITH MECHANICAL FEED.
- UNLESS SPECIFIED OTHERWISE TORQUE VALUES SHALL BE USED PER DOCUMENT, 101-35000.
- PLEASE REFER TO MOLEX APPLICATION TOOLING SPECIFICATION SHEET FOR COMPLETE TERMINAL LISTING.
- TERMINAL LUBRICANT IS RECOMMENDED.

***WARNING**
ON INSTALLATION, SET WIRE DISC TO CRIMP HEIGHT REFERENCE SETTING FOR LARGEST WIRE SIZE. CRIMP HEIGHT REFERENCE SETTINGS GREATER THAN THE VALUE SHOWN MAY CAUSE DAMAGE TO THE CRIMP TOOLING, REFER TO THE INSTRUCTION SHEET FOR PROPER SETUP AND ADJUSTMENTS.

ATLANTIC VERSION
Shown on sheets 1 of 4 & 2 of 4
(Pacific version shown on sheets 3 of 4 & 4 of 4)

DIMENSIONS:		TOLERANCES UNLESS OTHERWISE SPECIFIED:		MATERIAL:	
mm	0 PLC ±	1 PLC ±	2 PLC ±	3 PLC ±	4 PLC ±
	ANGLES ±	FINISH ±			

OWN	CHK	DATE	NAME	SIZE	CAGE CODE	DRAWING NO	RESTRICTED TO
L. ZHANG	L. ZHANG	18DEC2012		A1	00779	2151434	
L. ZHANG	L. ZHANG	18DEC2012					

Customer Accessible Production Drawing SCALE 1:2 SHEET 1 OF 4 REV G

LOC	DIST	REVISIONS			
P	LTN	DESCRIPTION	DATE	OWN	APVD
A	66	SEE SHEET 1	-	-	-

FEED TYPE

PNEUMATIC

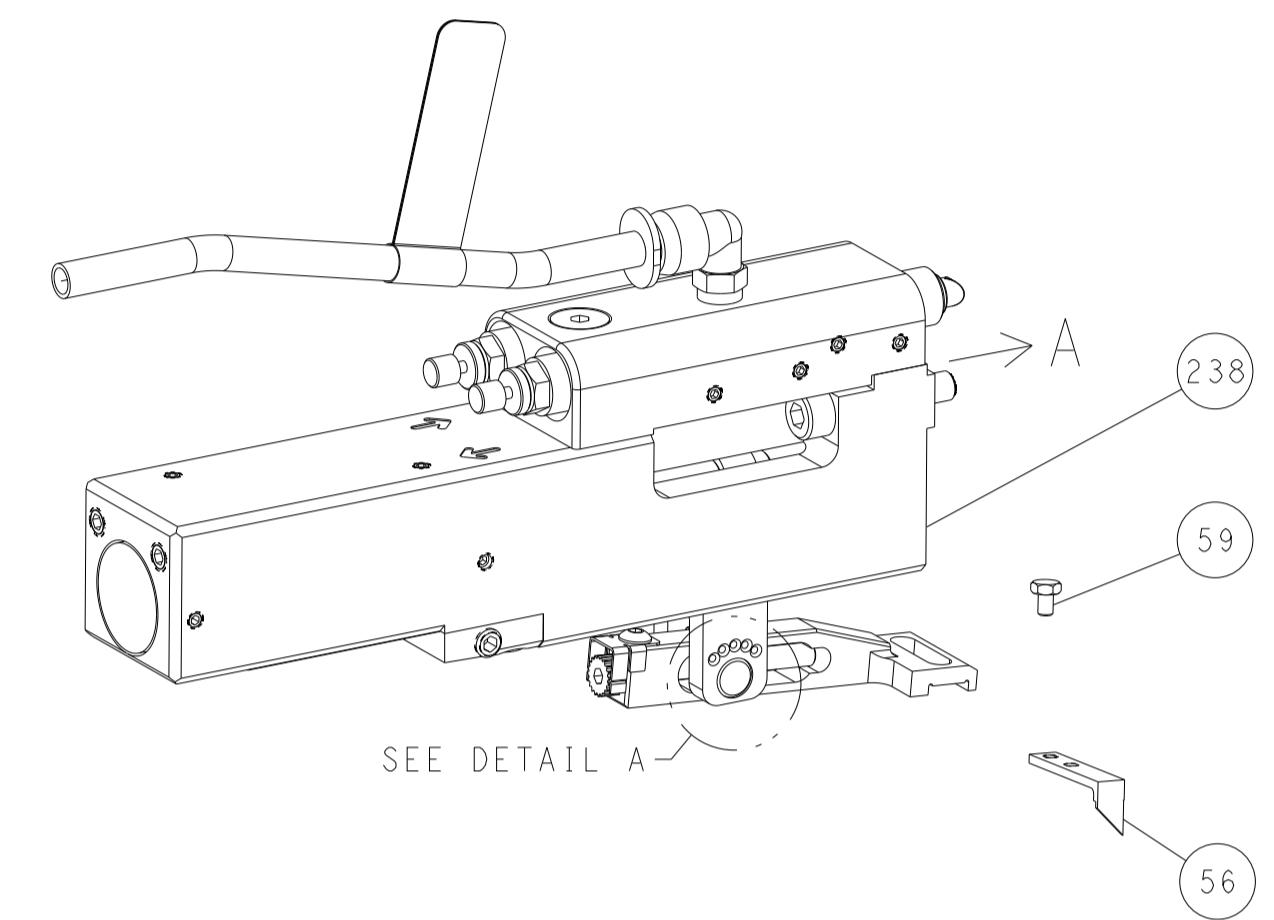

FEED SPRING SETTING POSITION
(SHOWN FROM REAR SIDE)

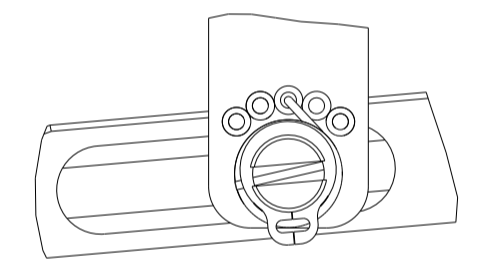

DETAIL A

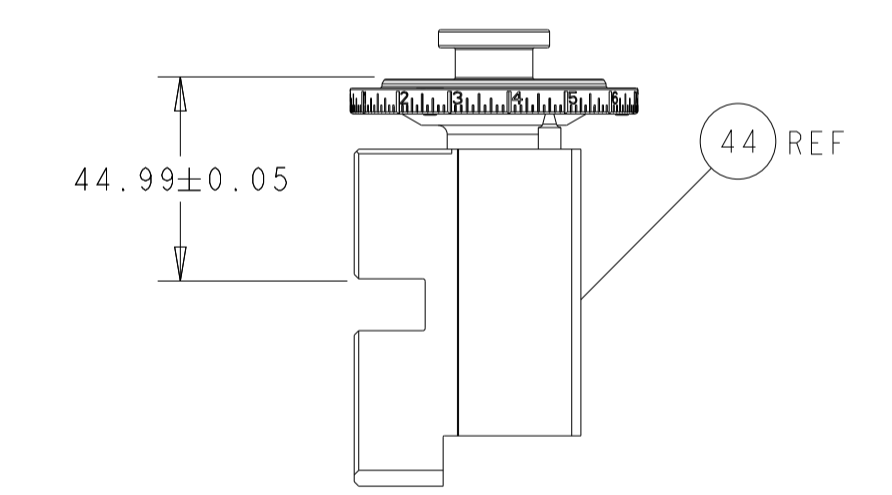
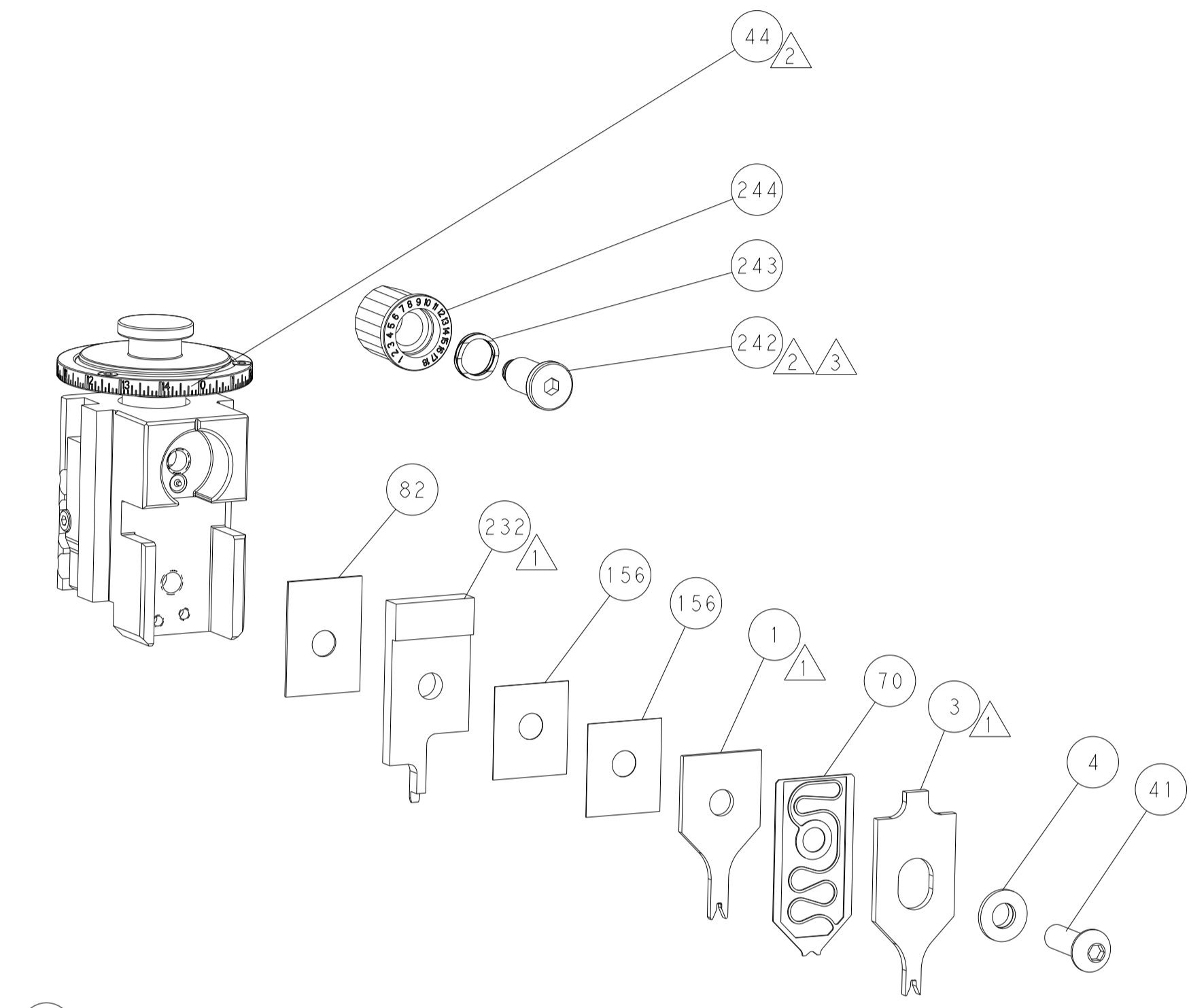

RAM SET-UP

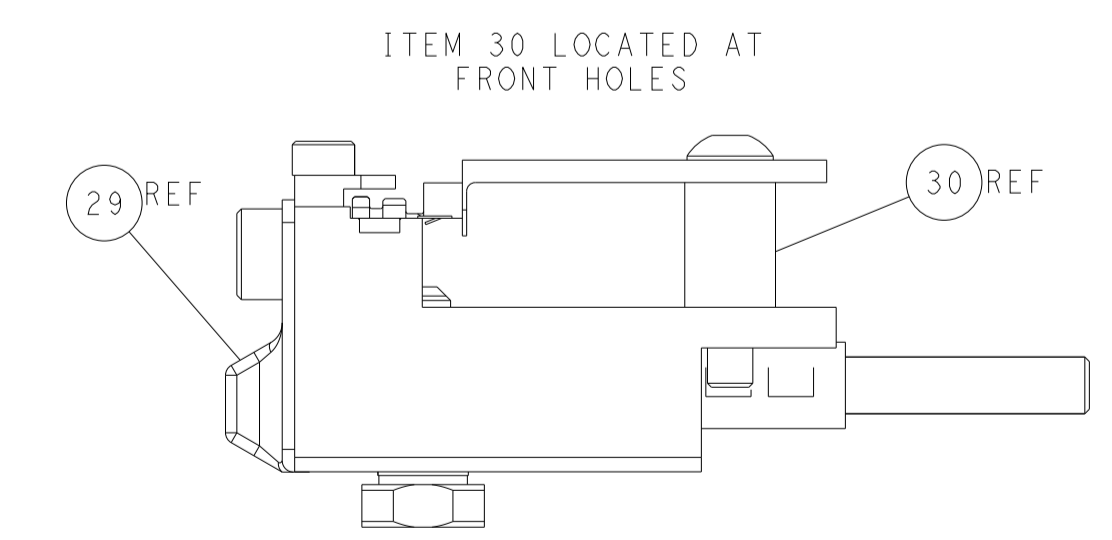
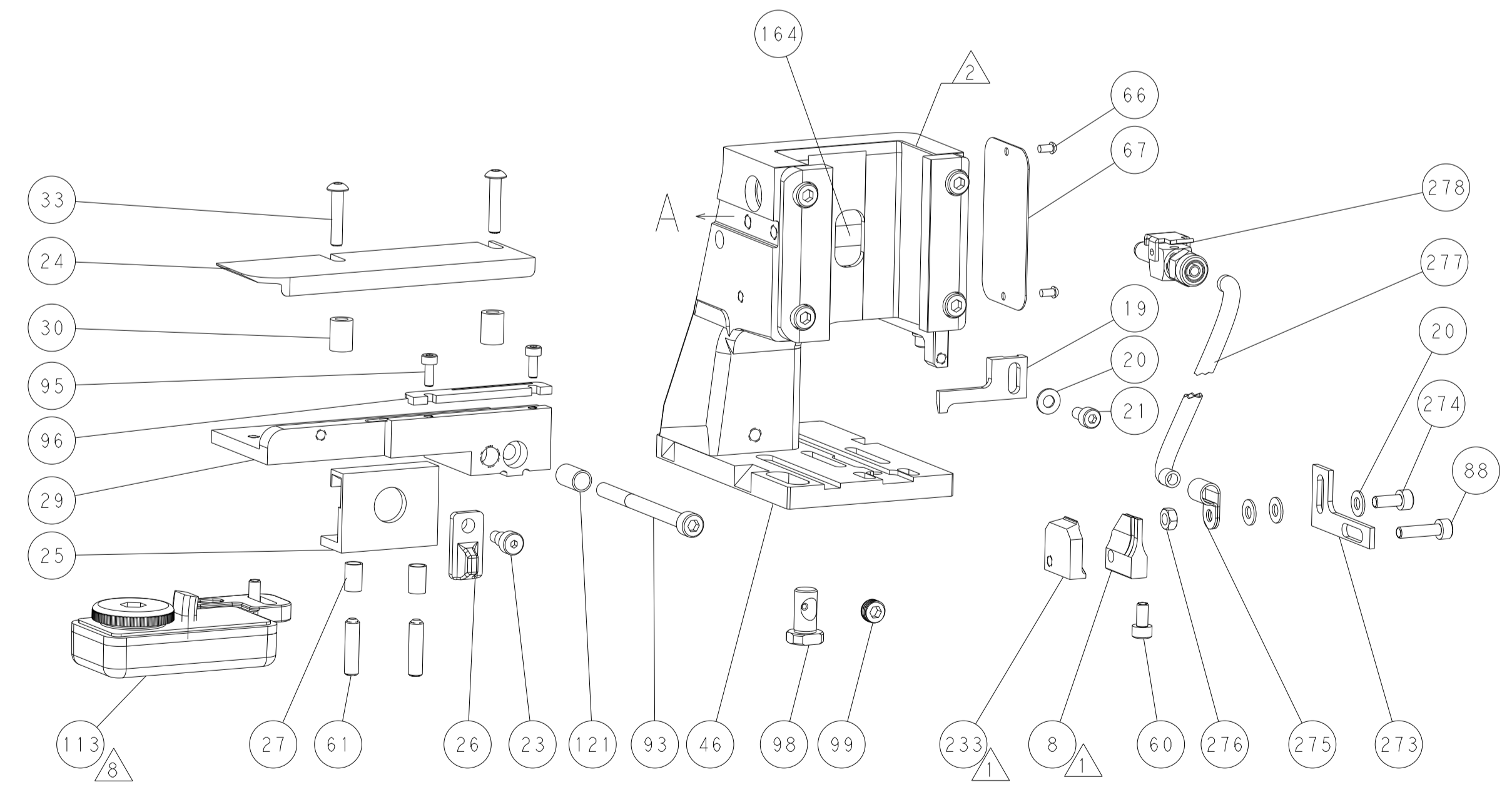

FEED TRACK POSITION
GUIDE BY TERMINAL BODY

CAM POSITION

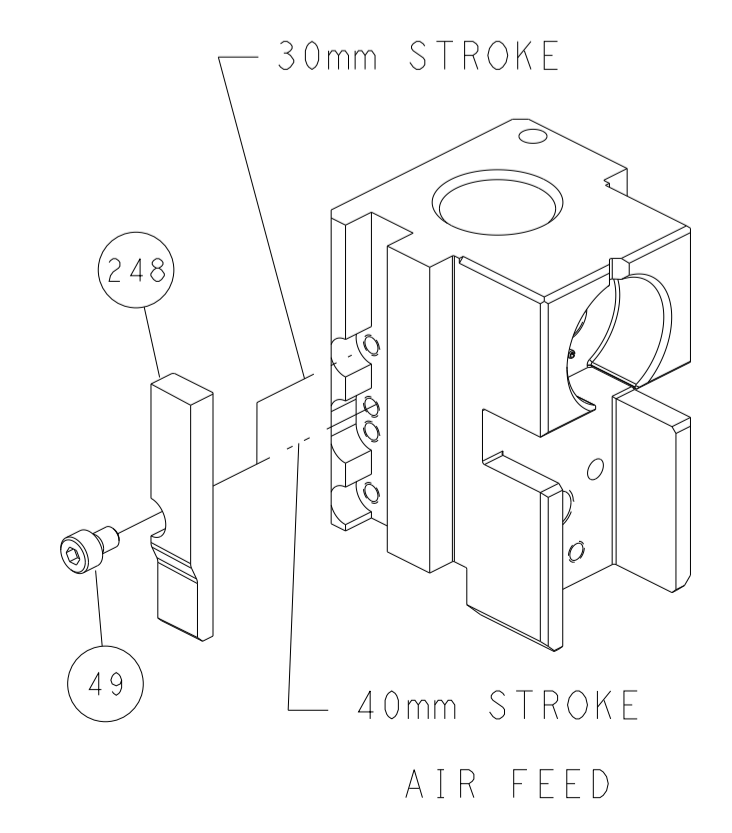

AIR FEED

ATLANTIC VERSION
 Shown on sheets 1 of 4 & 2 of 4
 (Pacific version shown on sheets 3 of 4 & 4 of 4)

<small>THIS DRAWING IS A CONTROLLED DOCUMENT FOR TYCO ELECTRONICS CORPORATION. IT IS THE PROPERTY OF COMPANY AND IS NOT TO BE REPRODUCED OR TRANSMITTED IN ANY FORM OR BY ANY MEANS, ELECTRONIC OR MECHANICAL, INCLUDING PHOTOCOPYING, RECORDING, OR BY ANY INFORMATION STORAGE AND RETRIEVAL SYSTEM, WITHOUT THE WRITTEN PERMISSION OF TYCO ELECTRONICS CORPORATION.</small>		DWN L. ZHANG 18DEC2012 CHK L. ZHANG 18DEC2012 APVD S. XI 18DEC2012	NAME Ocean Side Feed Applicator
DIMENSIONS: mm 	TOLERANCES UNLESS OTHERWISE SPECIFIED: 0 PLC ± 1 PLC ± 2 PLC ± 3 PLC ± 4 PLC ± ANGLES ± FINISH	SIZE A1 CAGE CODE 00779 DRAWING NO C=2151434	RESTRICTED TO G
MATERIAL:		WEIGHT:	SCALE: 1:2 SHEET: 2 OF 4 REV: G

PART NUMBER	REVISION	DESCRIPTION	FEED TYPE
2-2151434-2	G	FINE CRIMP HEIGHT ADJUST	PNEUMATIC
7-2151434-7	A	CRIMP TOOLING KIT	-

PACIFIC VERSION TERMINATOR
INTERFACE ADAPTER



APPLICATOR DATA		
CRIMP	SIZE	TYPE
WIRE	1.37 mm [.054]	F
INSUL	1.96 mm [.077]	F
APPLICATOR INSTRUCTIONS 408-35042		

TERMINAL DATA: MOLEX TERMINAL MOLEX CRIMP SPECIFICATION			
TERMINAL NAME: KK CRIMP TERMINAL			
WIRE STRIP LENGTH	INSULATION DIAMETER RANGE		
2.54-3.18 mm [.100-.125 IN]	Ø1.09-1.57 mm [.043-.062 IN]		
TERMINAL APPLICATION SPECIFICATION	ATS-638882000 REV E	-	-
TERMINALS APPLIED Δ 5/8			
TE TERMINAL	MOLEX TERMINAL	TE TERMINAL	MOLEX TERMINAL
286698-1	08-50-0113	286698-2	08-55-0101
286698-3	08-56-0109		

TERMINAL DATA: MOLEX TERMINAL MOLEX CRIMP SPECIFICATION			
TERMINAL NAME: KK CRIMP TERMINAL			
WIRE STRIP LENGTH	INSULATION DIAMETER RANGE		
2.54-3.18 mm [.100-.125 IN]	Ø1.09-1.57 mm [.043-.062 IN]		
TERMINAL APPLICATION SPECIFICATION	ATS-638882000 REV E	-	-
TERMINALS APPLIED Δ 5/8			
TE TERMINAL	MOLEX TERMINAL	TE TERMINAL	MOLEX TERMINAL
286698-4	08-52-0101	286698-5	08-65-0815
286698-6	08-65-0813	286698-7	97-00-0444
286698-8	08-55-0102	286698-9	08-70-0046
1-286698-0	08-52-0118	1-286698-1	08-52-0121
1-286698-2	08-50-0321	1-286698-3	08-65-0804
1-286698-4	08-65-0801	1-286698-5	08-65-0811
1-286698-6	08-65-0817	1-286698-7	40-07-0815
1-286698-8	97-00-0920		

TERMINAL DATA: MOLEX TERMINAL MOLEX CRIMP SPECIFICATION			
TERMINAL NAME: KK CRIMP TERMINAL			
WIRE STRIP LENGTH	INSULATION DIAMETER RANGE		
2.54-3.18 mm [.100-.125 IN]	Ø1.20-1.70 mm [.047-.067 IN]		
TERMINAL APPLICATION SPECIFICATION	ATS-638882000 REV E	-	-
TERMINALS APPLIED Δ 5/8			
TE TERMINAL	MOLEX TERMINAL	TE TERMINAL	MOLEX TERMINAL
1949741-1	08-70-0048	1949741-2	08-70-0064

WIRE SIZE	CRIMP HEIGHT mm [INCH]	CRIMP HEIGHT REFERENCE SETTING Δ 4
22 AWG	0.815+/-0.025 [.032+/- .001]	6.2
24 AWG	0.760+/-0.030 [.030+/- .001]	6.4
26 AWG	0.735+/-0.025 [.029+/- .001]	6.6
28 AWG	0.705+/-0.025 [.028+/- .001]	6.8
30 AWG	0.685+/-0.025 [.027+/- .001]	7.0

WIRE SIZE	CRIMP HEIGHT mm [INCH]	CRIMP HEIGHT REFERENCE SETTING Δ 4
22 AWG	0.815+/-0.025 [.032+/- .001]	6.2
24 AWG	0.765+/-0.025 [.030+/- .001]	6.4
26 AWG	0.710+/-0.030 [.028+/- .001]	6.6
28 AWG	0.685+/-0.025 [.027+/- .001]	6.8
30 AWG	0.645+/-0.015 [.026+/- .0005]	7.0

WIRE SIZE	CRIMP HEIGHT mm [INCH]	CRIMP HEIGHT REFERENCE SETTING Δ 4
22 AWG	0.815+/-0.025 [.032+/- .001]	6.2
24 AWG	0.765+/-0.025 [.030+/- .001]	6.4
26 AWG	0.710+/-0.030 [.028+/- .001]	6.6
28 AWG	0.685+/-0.025 [.027+/- .001]	6.8

- RECOMMENDED SPARE PARTS
- REFER TO SUPPLIED INSTRUCTION SHEET FOR CLEANING, LUBRICATION AND STORAGE OF APPLICATOR.
- APPLY PART NUMBER 2-23419-6 LOCTITE TO THREADS OF ITEM 242.
- CRIMP HEIGHT REFERENCE SETTING WAS THE SETTING USED WHEN THE APPLICATOR WAS QUALIFIED AT THE FACTORY. ADJUSTMENT MAY BE NECESSARY WHEN RUNNING APPLICATOR IN THE FIELD.
- TERMINAL PITCH NOT COMPATIBLE WITH MECHANICAL FEED.
- 6. UNLESS SPECIFIED OTHERWISE TORQUE VALUES SHALL BE USED PER DOCUMENT, 101-35000.
- 7. PLEASE REFER TO MOLEX APPLICATION TOOLING SPECIFICATION SHEET FOR COMPLETE TERMINAL LISTING.
- TERMINAL LUBRICANT IS RECOMMENDED.

***WARNING**
ON INSTALLATION, SET WIRE DISC TO CRIMP HEIGHT REFERENCE SETTING FOR LARGEST WIRE SIZE. CRIMP HEIGHT REFERENCE SETTINGS GREATER THAN THE VALUE SHOWN MAY CAUSE DAMAGE TO THE CRIMP TOOLING, REFER TO THE INSTRUCTION SHEET FOR PROPER SETUP AND ADJUSTMENTS.

PACIFIC VERSION
Shown on sheets 3 of 4 & 4 of 4
(Atlantic version shown on sheets 1 of 4 & 2 of 4)

LOC	DIST	REVISIONS					
A	66	P	LTN	DESCRIPTION	DATE	OWN	APVD
		-		SEE SHEET 1	-	-	-

-	1	23238-1	INSERT, COUPLING	278	
-	1	2030758-3	TUBING, POLYURETHANE	277	
-	1	5018030-2	NUT, HEX, REG, RoHS, M4	276	
-	1	986220-3	CLAMP, CABLE, BLACK	275	
-	1	1-2168083-0	SCR, SKT HD CAP, RoHS, M4 X 10	274	
-	1	2217068-1	BRACKET, AIR BLAST	273	
-	1	2119082-5	CAM, SNAIL, INSULATION ADJUSTMENT	244	
-	1	2079764-1	WASHER, WAVE SPRING, CREST-TO-CREST	243	
-	1	2119083-1	RETAINER, INSULATION DIAL	242	
-	1	2844940-1	AIR FEED MODULE	238	
-	1	2391993-1	PLATE, REAR SHEAR	233	
-	1	1803174-3	BLADE, SLUG	232	
-	REF	994970-2	COUNTER, MAGNETIC	164	
-	2	2031943-1	SPACER, CRIMPER, SPECIAL	156	
-	1	2119641-2	FEED CAM, AIR FEED	151	
-	1	2168083-8	SCR, SKT HD CAP, RoHS, M4 X 16	144	
-	1	1-1803583-0	APPLICATOR BASIC ASSEMBLY, SF	141	
-	1	1803516-1	RAM ASSEMBLY, SF PACIFIC	140	
-	1	1-22281-8	SPRING, COMPRESSION	121	
-	1	2119955-1	ASSY, LUBRICATOR, SIDE FEED	113	
-	1	2844908-1	SCREW, LOCKING	99	
-	1	2844907-1	POST, LOCKING	98	
-	1	2-690487-2	GUIDE, FRONT STRIP	96	
-	2	2168083-1	SCR, SKT HD CAP, RoHS, M3 X 8.0	95	
-	1	2168083-6	SCR, SKT HD CAP, RoHS, M5 X 65	93	
-	1	2168083-8	SCR, SKT HD CAP, RoHS, M4 X 16	88	
-	1	455888-7	SPACER, CRIMPER	82	
-	1	1803607-3	DOCUMENTATION PACKAGE	71	
-	1	2119791-9	DEPRESSOR, WIRE	70	
-	1	2119740-1	TAG, IDENTIFICATION	67	
-	2	2168078-1	SCREW, DRIVE, RH, RoHS, 2 x .188	66	
-	2	2-18032-5	SCR, SET, FLT PNT, M5 X 20.0	61	
-	1	5-18022-5	SCR, HEX HD CAP, M4 X 6.0	59	
-	1	1338685-1	PAWL, FEED	56	
-	1	18023-9	SCR, SKT HD CAP M4 X 6.0	49	
-	1	1803602-1	SCR, BHSC, RoHS (M8 X 25)	41	
-	2	2079383-5	SCR, BHSC, RoHS (M4 X 20)	33	
-	2	1-2844962-3	SPACER, CYLINDRICAL, STRIP GUIDE	30	
-	1	2-2844938-9	PLATE, STRIP GUIDE	29	
-	2	22280-1	SPRING, COMPRESSION	27	
-	1	356835-1	LEVER, DRAG RELEASE	26	
-	1	1-690754-5	DRAG, SPECIAL	25	
-	1	1320928-2	STRIP GUIDE	24	
-	1	980371-4	SCR, SKT HD SHLDR 5.0 DIA X 6.0	23	
-	1	2168083-2	SCR, SKT HD CAP, RoHS, M4 X 8.0	21	
-	4	1-18028-2	WASHER, FLAT, REG M4	20	
-	1	1-2119533-1	STRIPPER, SIDE FEED	19	
-	-	-	-	10	
-	-	-	-	9	
Δ 1	1	1	2031312-3	ANVIL, SPECIAL	8
-	-	-	-	7	
-	-	-	-	6	
-	-	-	-	5	
-	1	1	1803409-8	BLOCK, CRIMPER SPACER	4
Δ 1	1	1	3-1803017-6	CRIMPER, INSULATION F	3
-	-	-	-	2	
Δ 1	1	1	1803173-1	CRIMPER, WIRE	1

DIMENSIONS:		TOLERANCES UNLESS OTHERWISE SPECIFIED:		DWG		REV	
mm	0 PLC ±	1 PLC ±	2 PLC ±	3 PLC ±	4 PLC ±	5 PLC ±	6 PLC ±
	ANGLES	FINISH		DATE	DATE	DATE	DATE
MATERIAL				18DEC2012	18DEC2012	18DEC2012	18DEC2012
Customer Accessible Production Drawing				SCALE	SHEET	OF	REV
				1:2	3	4	G

LOC	DIST	REVISIONS					
		P	LTN	DESCRIPTION	DATE	DWN	APVD
A	66	-	-	SEE SHEET 1	-	-	-

FEED TYPE PNEUMATIC

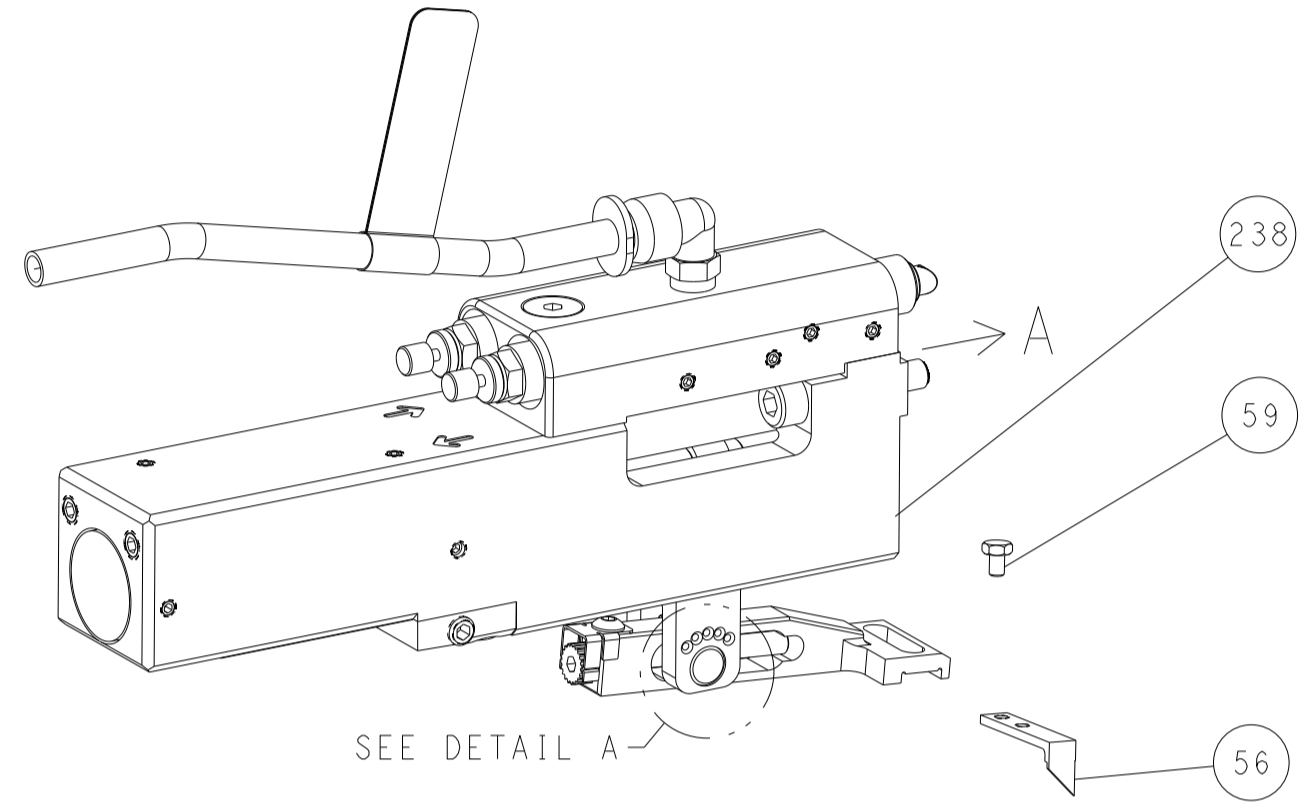

FEED SPRING SETTING POSITION (SHOWN FROM REAR SIDE)

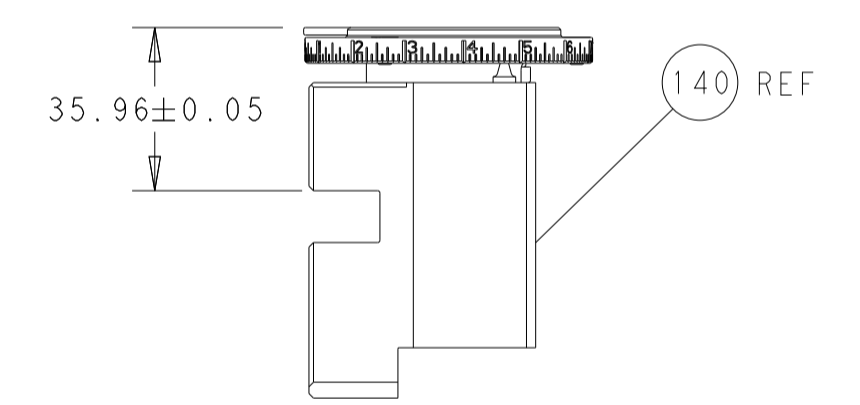
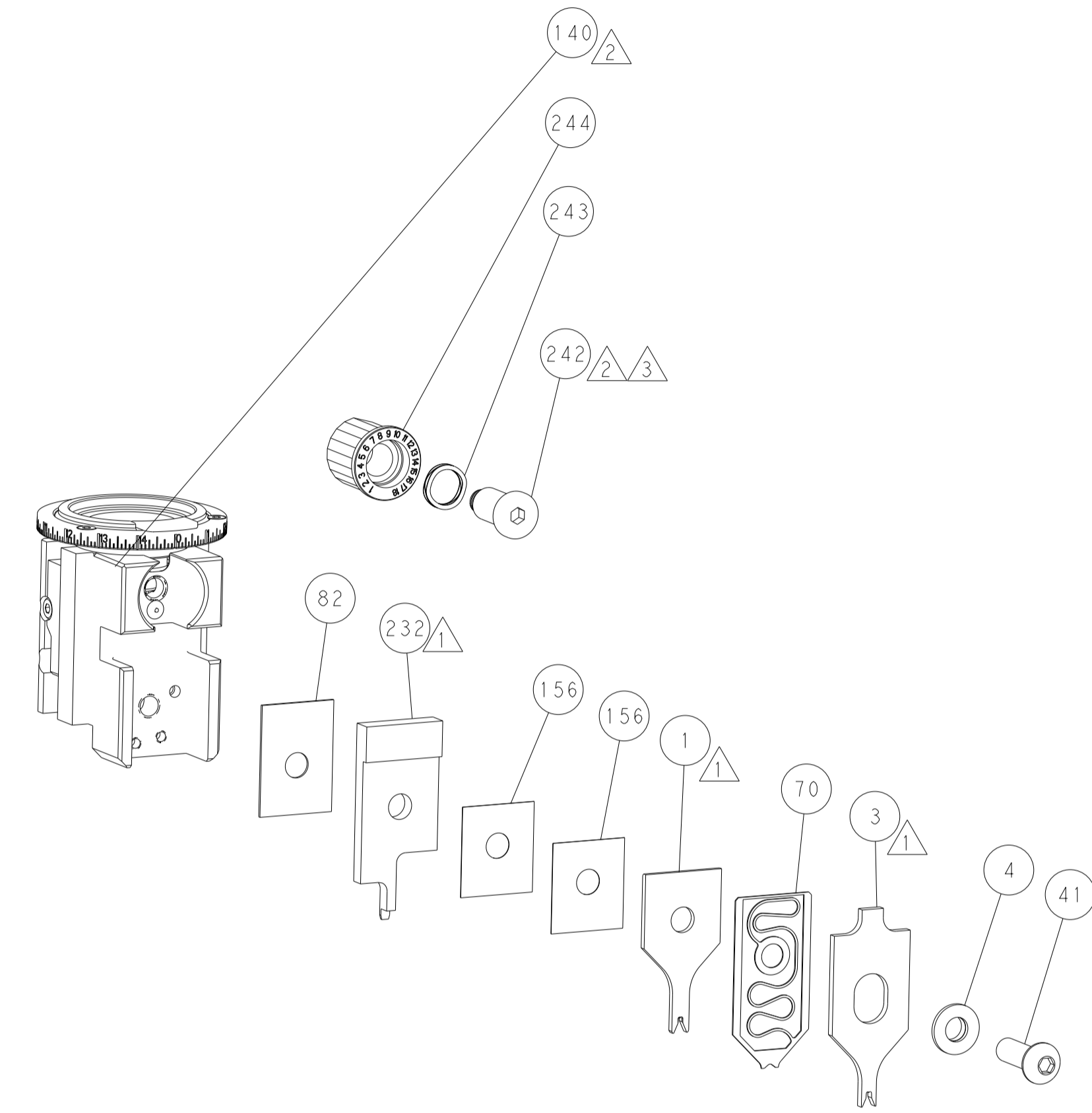
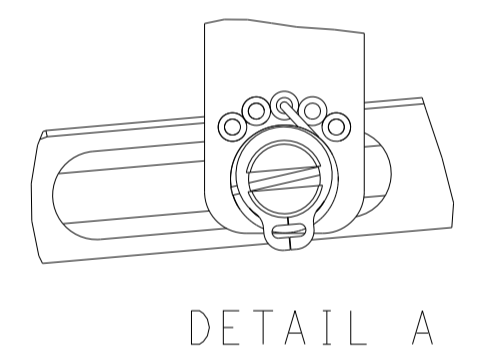

CAM POSITION

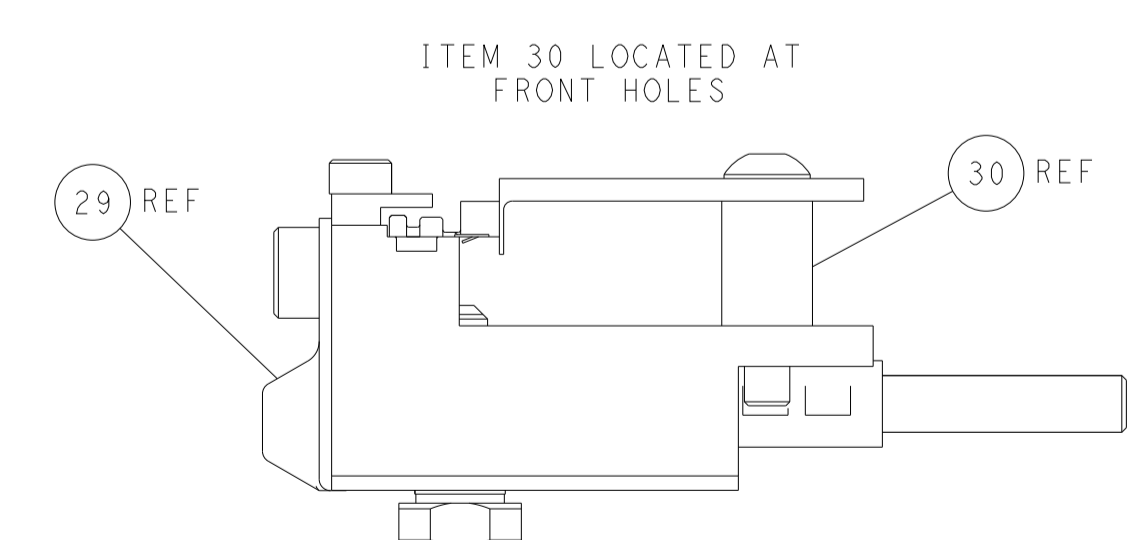
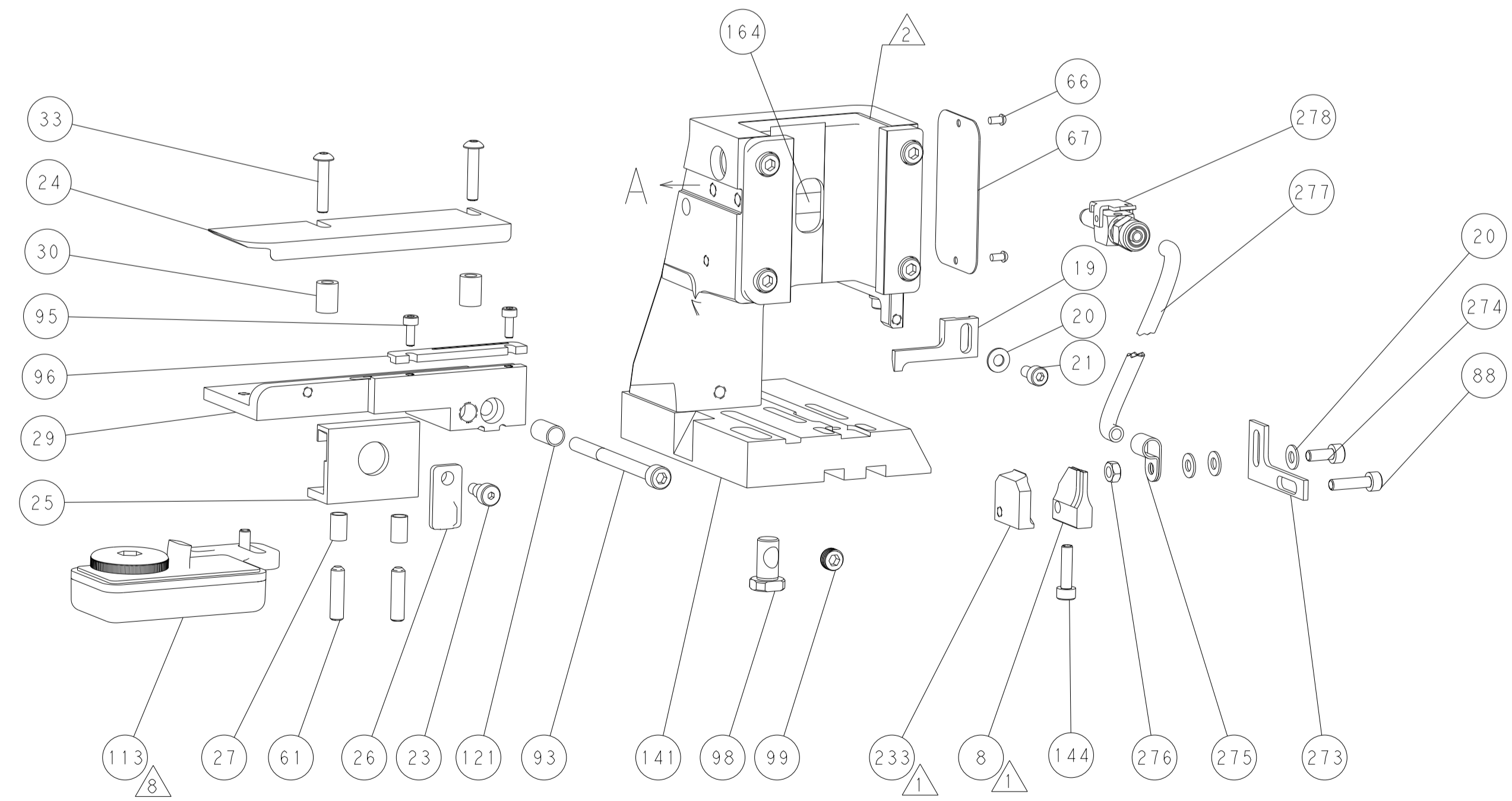
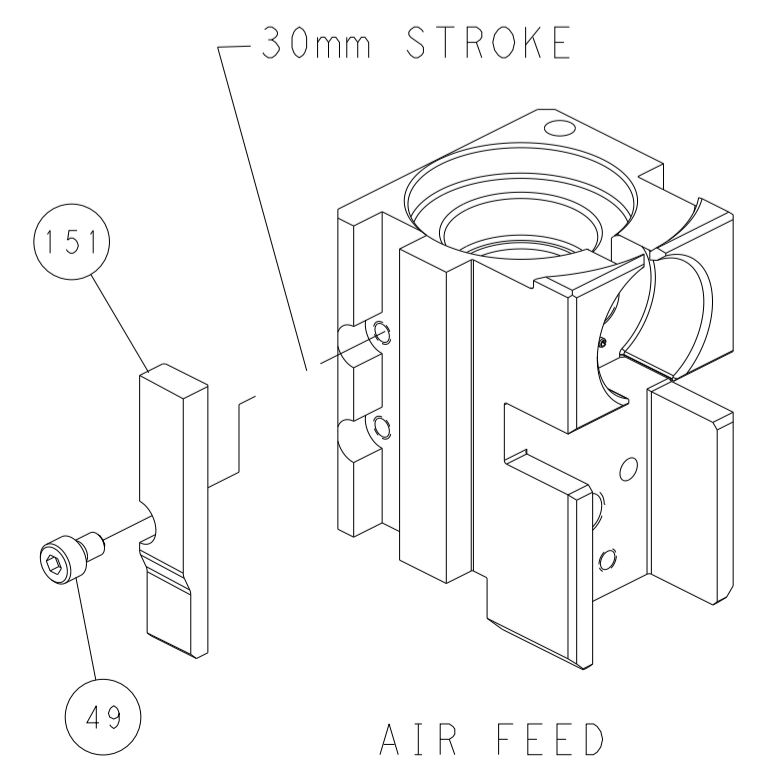

PACIFIC VERSION
 Shown on sheets 3 of 4 & 4 of 4
 (Atlantic version shown on sheets 1 of 4 & 2 of 4)

<small>THIS DRAWING IS UNPUBLISHED. RELEASED FOR PUBLICATION 20. COPYRIGHT 20 BY TYCO ELECTRONICS CORPORATION. ALL RIGHTS RESERVED.</small>		DWN: L. ZHANG 18DEC2012 CHK: L. ZHANG 18DEC2012 S. XI 18DEC2012 APVD: S. XI 18DEC2012	TE Connectivity Harrisburg, PA 17105-3608
DIMENSIONS: mm TOLERANCES UNLESS OTHERWISE SPECIFIED: 0 PLC ± 1 PLC ± 2 PLC ± 3 PLC ± 4 PLC ± ANGLES ± FINISH		NAME: Ocean Side Feed Applicator APPLICATION SPEC: - PRODUCT SPEC: - SIZE: A1 CAGE CODE: 00779 DRAWING NO: 2151434 SCALE: 1:2 SHEET: 4 of 4 REV: G	RESTRICTED TO: - CUSTOMER ACCESSIBLE PRODUCTION DRAWING