

Recommended PCB Layout
As viewed from component side

▨ Solder Area □ Component Outline

Specifications

Material
Housing: LCP,UL 94V-0, Natural
Actuator: LCP,UL 94V-0, Black
Contact: Phosphor Bronze
Fitting Nail: Phosphor Bronze

Plating
Contact: See Ordering Grid
Fitting Nail: Matte Tin Plating over Nickel

Electrical
Voltage Rating: 30V AC/DC
Current Rating : 0.2A AC/DC

Mechanical & Environmental
Durability: 20 Cycles
Operating Temperature: -55°C to +85°C
Solder Profile:
Peak Temp 260°C (+0/-5°C) max. (5 seconds)

Ordering Grid

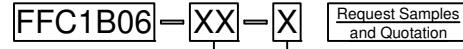

No. of Contacts
13 - 51
(see dimension table)

Contact Plating
G = Gold Flash over all (Standard)
T = Tin Plating over all

No. of Contacts	Dimensions				
	A	B	C	D	E
* 13	5.40	3.00	3.60	4.25	4.90
14	5.70	3.30	3.90	4.55	5.20
* 15	6.00	3.60	4.20	4.85	5.50
16	6.30	3.90	4.50	5.15	5.80
* 17	6.60	4.20	4.80	5.45	6.10
18	6.90	4.50	5.10	5.75	6.40
* 19	7.20	4.80	5.40	6.05	6.70
20	7.50	5.10	5.70	6.35	7.00
* 21	7.80	5.40	6.00	6.65	7.30
22	8.10	5.70	6.30	6.95	7.60
* 23	8.40	6.00	6.60	7.25	7.90
24	8.70	6.30	6.90	7.55	8.20
* 25	9.00	6.60	7.20	7.85	8.50
26	9.30	6.90	7.50	8.15	8.80
* 27	9.60	7.20	7.80	8.45	9.10
28	9.90	7.50	8.10	8.75	9.40
* 29	10.20	7.80	8.40	9.05	9.70
30	10.50	8.10	8.70	9.35	10.00
* 31	10.80	8.40	9.00	9.65	10.30
32	11.10	8.70	9.30	9.95	10.60
* 33	11.40	9.00	9.60	10.25	10.90
34	11.70	9.30	9.90	10.55	11.20
* 35	12.00	9.60	10.20	10.85	11.50
36	12.30	9.90	10.50	11.15	11.80
* 37	12.60	10.20	10.80	11.45	12.10
38	12.90	10.50	11.10	11.75	12.40
* 39	13.20	10.80	11.40	12.05	12.70
40	13.50	11.10	11.70	12.35	13.00
* 41	13.80	11.40	12.00	12.65	13.30
42	14.10	11.70	12.30	12.95	13.60
43	14.40	12.00	12.60	13.25	13.90
44	14.70	12.30	12.90	13.55	14.20
* 45	15.00	12.60	13.20	13.85	14.50
46	15.30	12.90	13.50	14.15	14.80
47	15.60	13.20	13.80	14.45	15.10
48	15.90	13.50	14.10	14.75	15.40
* 49	16.20	13.80	14.40	15.05	15.70
50	16.50	14.10	14.70	15.35	16.00
* 51	16.80	14.40	15.00	15.65	16.30

* = Tooled Parts
Please contact GCT for non-tooled parts

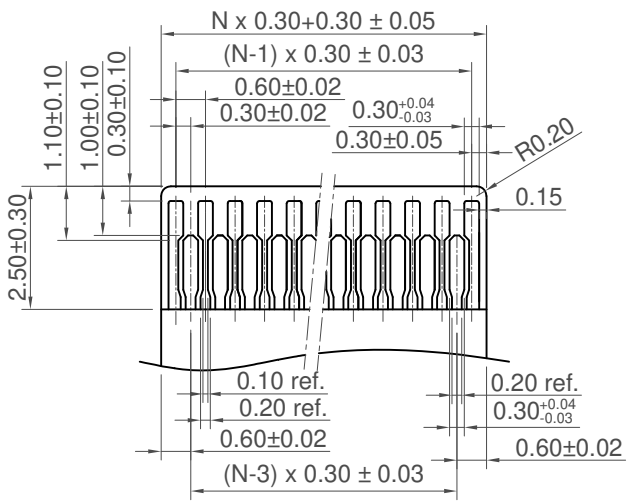

Recommended FFC/FPC Dimensions

Part Number		Product Description	
FFC1B06		FPC 0.3mm Pitch, Side Entry, Bottom Contact, SMT, Height=1.0mm, Front Flip	
Drawing Date		5th August 2019	
By	CC	Tolerances (Except as Noted)	Units:
Detail	Drawing Release	Length	Metric (mm)
Revision	A1	Angle	3rd Angle Projection
Date	13/08/19	X.X ± 0.30	X.X° ± 5°
		X.XX ± 0.20	X.XX° ± 2°
		X.XXX ± 0.10	X.XXX° ± 1°



This drawing is confidential and copyright of Global Connector Technology, Ltd (GCT). This drawing must not be copied or disclosed without written consent. E & OE



Not to Scale	Drawn By CC	Sheet No. 1/2
--------------	-------------	---------------

H
G
F
E
D
C
B
A

1 2 3 4 5 6 7 8

H
G
F
E
D
C
B
A

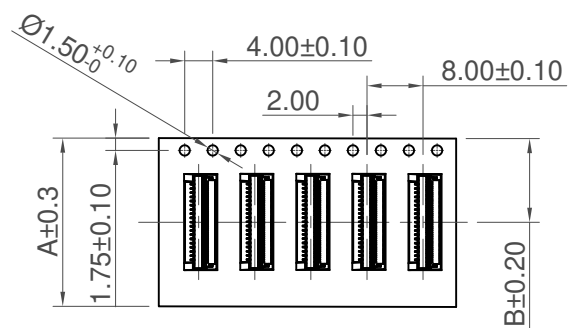
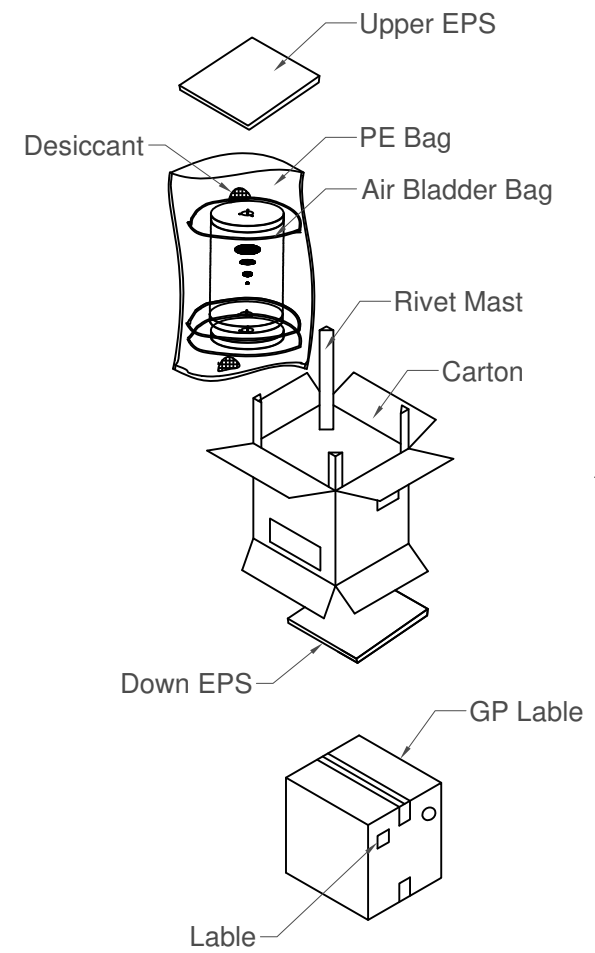
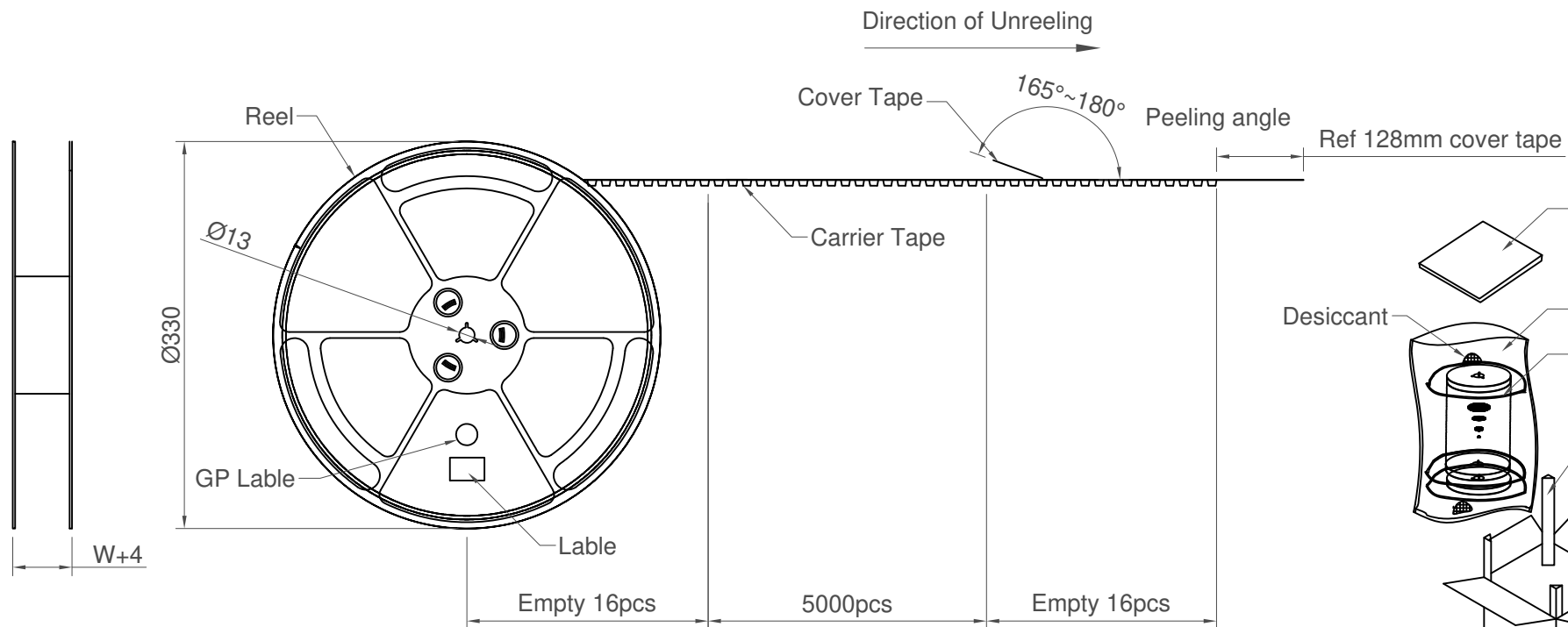

Direction of Unreeling
16mm&24mm Carrier

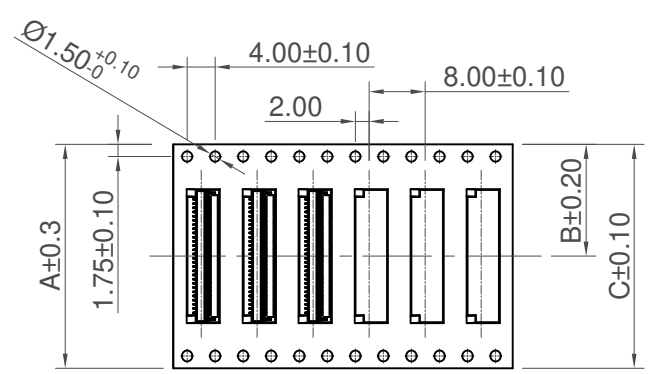

Direction of Unreeling
32mm Carrier

No. of Contacts	Dimensions				Pcs./Reel	Reels/Carton	Pcs./Carton
	W	A	B	C			
13 ~ 25	20.5	16	7.5	/	5000	14	65000
26 ~ 49	28.5	24	11.5	/	5000	10	50000
50 ~ 51	36.5	32	14.2	28.4	5000	8	40000

Part Number		Product Description	
FFC1B06		FPC 0.3mm Pitch, Side Entry, Bottom Contact, SMT, Height=1.0mm, Front Flip	
Drawing Date		5th August 2019	
By	CC	Tolerances (Except as Noted)	Units:
Detail	Drawing Release	Length	Metric (mm)
Revision	A1	X.X ± 0.30	X.X° ± 5°
Date	13/08/19	X.XX ± 0.20	X.XX° ± 2°
		X.XXX ± 0.10	X.XXX° ± 1°



This drawing is confidential and copyright of Global Connector Technology, Ltd (GCT). This drawing must not be copied or disclosed without written consent. E & OE



Not to Scale	Drawn By CC	Sheet No. 2/2
--------------	-------------	---------------

1 2 3 4 5 6 7 8