

OBSOLETE – PART DISCONTINUED

Description

The AP3409/A is a current mode, PWM synchronous buck DC/DC converter, capable of driving a 3A load with high efficiency, excellent line and load regulation. It operates in continuous PWM mode.

The AP3409/A integrates synchronous P-channel and N-channel power MOSFET switches with low on-resistance. It is ideal for portable applications powered from a single Li-ion battery. 100% duty cycle and low on-resistance P-channel internal power MOSFET can maximize the battery life.

The switching frequency of AP3409/A can be programmable from 300kHz to 4MHz, which allows small-sized components, such as capacitors and inductors. A standard series of inductors from several different manufacturers are available. This feature greatly simplifies the design of switch-mode power supplies.

The AP3409/A is available in U-DFN3030-10 package.

Features

- Input Voltage Range: 2.6V to 5.5V
- Adjustable Output from 0.8V to 5V
- 0.8V Reference Voltage with $\pm 2\%$ Precision
- Output Current: 3A
- High Efficiency up to 95%
- Low $R_{DS(ON)}$ Internal Switches
- Programmable Frequency: 300kHz to 4MHz
- Current Mode Control
- Forced Continuous-mode Operation
- 100% Duty Cycle
- Built-in Soft-start
- Built-in Short Circuit Protection
- Built-in Thermal Shutdown Protection
- Built-in Current Limit Function
- PGOOD Output Voltage Monitoring (For AP3409A)
- U-DFN3030-10 package
- **Totally Lead-free & Fully RoHS Compliant (Note 1 & 2)**
- **Halogen and Antimony Free. "Green" Device (Note 3)**

- Notes:
1. No purposely added lead. Fully EU Directive 2002/95/EC (RoHS) & 2011/65/EU (RoHS 2) compliant.
 2. See http://www.diodes.com/quality/lead_free.html for more information about Diodes Incorporated's definitions of Halogen- and Antimony-free, "Green" and Lead-free.
 3. Halogen- and Antimony-free "Green" products are defined as those which contain <900ppm bromine, <900ppm chlorine (<1500ppm total Br + Cl) and <1000ppm antimony compounds.

Pin Assignments

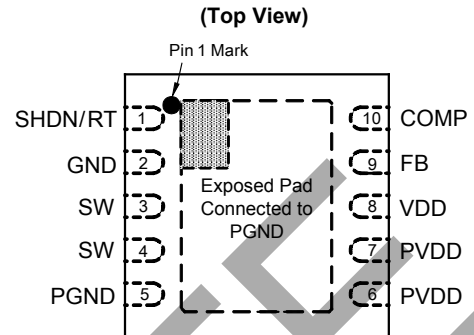

**U-DFN3030-10 (DN Package)
For AP3409**

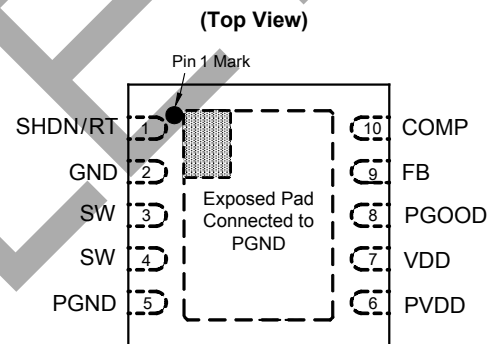

**U-DFN3030-10 (DN Package)
For AP3409A**

Applications

- Portable Media Player
- Digital Still and Video Cameras
- Notebook

Typical Applications Circuit (Note 4)

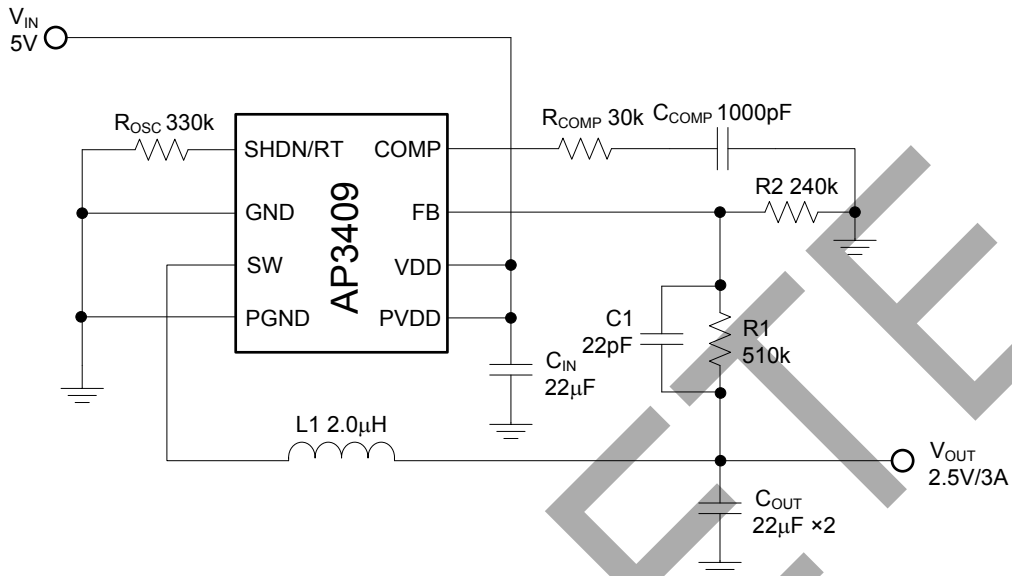

Typical Application of AP3409

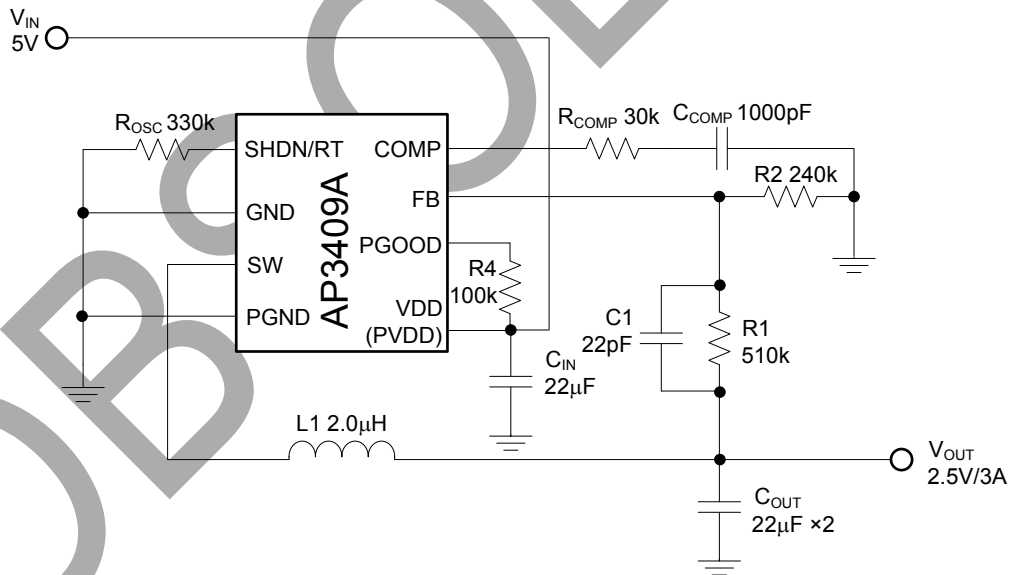

Typical Application of AP3409A

Notes 4: $V_{OUT} = \frac{V_{FB} \times (R1 + R2)}{R2}$

OBSOLETE - PART DISCONTINUED

Pin Descriptions

Pin Number		Pin Name	Function
AP3409	AP3409A		
1	1	SHDN/RT	Oscillator resistor input. Connect a resistor to GND from this pin to set the switching frequency. Forcing this pin to V_{DD} to shutdown the device
2	2	GND	Signal ground. All small-signal ground, such as the compensation components and exposed pad should be connected to this, which in turn connects to PGND at one point
3, 4	3, 4	SW	Internal power switch output. Connect this pin with one terminal of the inductor
5	5	PGND	Power ground. Connect this pin as close as possible to C_{IN} and C_{OUT}
6, 7	6	PVDD	Power Input Supply. Decouple this pin to PGND with a capacitor
8	7	VDD	Signal input supply. Decouple this pin to GND with a capacitor. Normally V_{DD} is equal to V_{PVDD}
-	8	PGOOD	Power good indicator. This pin is open-drain logic output that is pulled to ground when the output voltage is not within $\pm 12.5\%$ of regulation point
9	9	FB	Feedback voltage. This pin is the inverting input of internal error amplifier. It senses the converter output voltage through an external resistor divider. The internal reference voltage is 0.8V, which determines the output voltage through the resistor divider
10	10	COMP	Compensation input. This pin is the output of internal error amplifier. Connect external compensation elements to this pin to stabilize the control loop

Functional Block Diagram

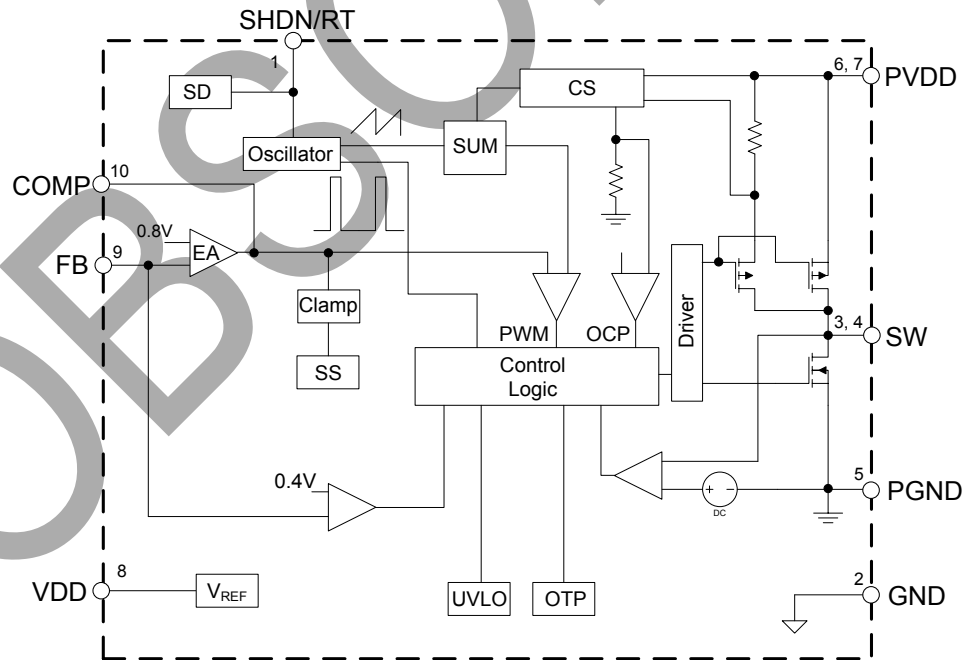

Functional Block Diagram of AP3409

OBSOLETE - PART DISCONTINUED

Functional Block Diagram (Cont.)

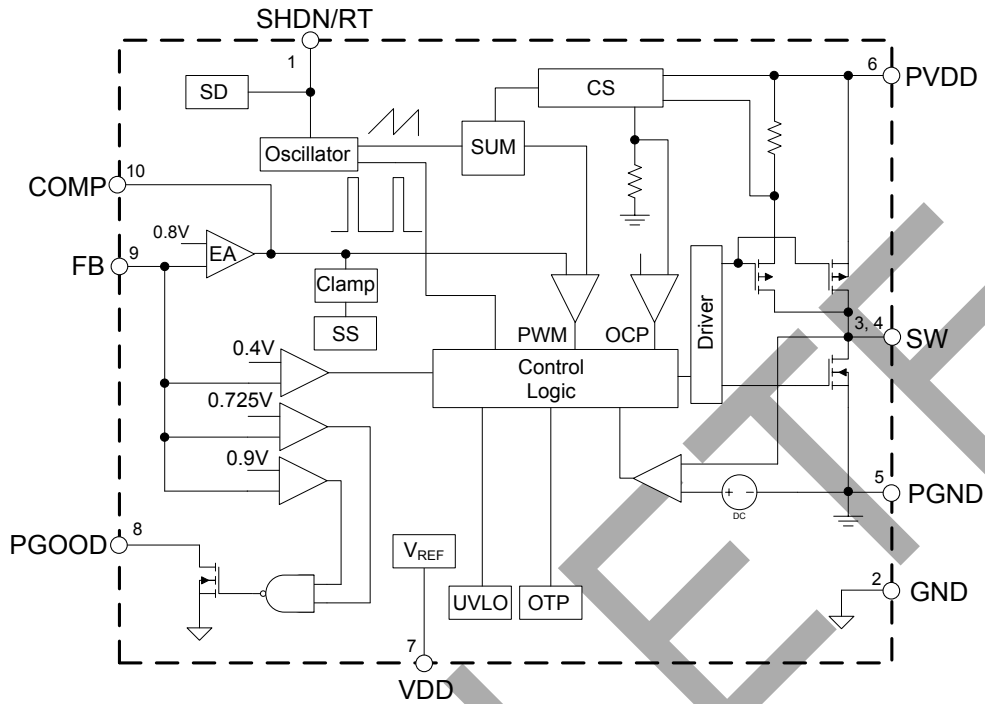

Functional Block Diagram of AP3409A

Absolute Maximum Ratings (Note 5)

Symbol	Parameter	Rating	Unit
V _{DD}	VDD Pin Voltage	-0.3 to 6	V
V _{PVDD}	PVDD Pin Voltage	-0.3 to 6	V
V _{FB}	FB Pin Voltage	-0.3 to 6	V
V _{COMP}	COMP Pin Voltage	-0.3 to 6	V
V _{SW}	SW Pin Voltage	-0.3 to V _{IN} +0.3	V
V _{RT}	SHDN/RT Pin Voltage	-0.3 to 6	V
θ _{JA}	Thermal Resistance (Junction to Ambient)	110	°C/W
θ _{JC}	Thermal Resistance (Junction to Case)	3	°C/W
T _J	Operating Junction Temperature	+150	°C
T _{STG}	Storage Temperature	-65 to +150	°C
T _{LEAD}	Lead Temperature (Soldering, 10 sec)	+260	°C
-	ESD (Machine Model)	200	V
-	ESD (Human Body Model)	2000	V

Note 5: Stresses greater than those listed under "Absolute Maximum Ratings" may cause permanent damage to the device. These are stress ratings only, and functional operation of the device at these or any other conditions beyond those indicated under "Recommended Operating Conditions" is not implied. Exposure to "Absolute Maximum Ratings" for extended periods may affect device reliability.

Recommended Operating Conditions

Symbol	Parameter	Min	Max	Unit
V _{IN}	Input Voltage	2.6	5.5	V
I _{OUT (MAX)}	Maximum Output Current	3	–	A
T _J	Operating Junction Temperature	-40	+125	°C

Electrical Characteristics (V_{IN}=V_{DD}=V_{PVDD}=3.3V, T_A=+25°C, unless otherwise specified.)

Symbol	Parameter	Conditions	Min	Typ	Max	Unit	
INPUT SECTION							
V _{DD}	Input Voltage Range		2.6	–	5.5	V	
I _Q	Supply Current	V _{FB} =0.75V, No Switching	–	460	–	μA	
I _{SHDN}	Shutdown Supply Current	Shutdown, V _{IN} =5.5V	–	–	1	μA	
V _{UVLO}	Under Voltage Threshold Lockout	V _{DD} Rising	–	2.2	–	V	
V _{HUVLO}	Under Voltage Hysteresis Lockout	–	–	300	–	mV	
FEEDBACK SECTION							
V _{FB}	Feedback Voltage	–	0.784	0.8	0.816	V	
I _{FB}	FB Pin Bias Current	–	–	0.1	0.4	μA	
R _T	Current Sense Trans-resistance	–	–	0.2	–	Ω□	
–	Switching Leakage Current	V _{SHDN/RT} =V _{IN} =5.5V	–	–	1	μA	
G _V	Error Gain Amplifier Voltage	–	–	800	–	–	
G _S	Error Amplifier Trans-conductance	–	–	800	–	μA/V	
OSCILLATOR SECTION							
V _{RT}	RT Pin Voltage	–	0.76	0.8	0.84	V	
f _{OSC}	Switching Frequency	R _{OSC} =330kΩ□	0.8	1	1.2	MHz	
	ADJ Frequency		0.3	–	4	MHz	
D _{MAX}	Maximum Duty Cycle	V _{FB} =0.75V	100	–	–	%	
POWER SWITCH SECTION							
I _{LIMIT}	Switch Current Limit	AP3409	V _{FB} =0.75V	3.2	4.2	–	A
		AP3409A		3.5	4.2	–	A
R _{PDSN}	Internal P-FET On Resistance	I _{SW} =500mA	–	0.11	0.16	Ω	
R _{NDSN}	Internal N-FET On Resistance	I _{SW} =-500mA	–	0.11	0.17	Ω	
SHDN/RT SECTION							
–	Shutdown Threshold	–	–	V _{DD} -0.7	V _{DD} -0.4	V	
PGOOD SECTION (Only for AP3409A)							
–	PGOOD Voltage Range	–	–	±12.5	±15	%	
–	PGOOD Pull Down Resistance	–	–	–	120	Ω	
TOTAL DEVICE							
I _{OUT}	Output Current	V _{DD} =2.6V to 5.5V, V _{OUT} =2.5V	3	–	–	A	
LNR	Output Voltage Line Regulation	V _{DD} =2.7V to 5.5V, I _{OUT} =100mA	–	0.4	–	%/V	
LOD	Output Voltage Load Regulation	I _{OUT} =0.01A to 3A	–	±0.2	–	%	
t _{SS}	Soft-start Time	I _{OUT} =10mA	–	1.5	–	ms	
T _{TSD}	Thermal Shutdown Temperature	–	–	+160	–	°C	
T _{HYS}	Thermal Shutdown Temperature Hysteresis	–	–	+20	–	°C	

Performance Characteristics ($V_{IN}=V_{DD}=V_{PVDD}=3.3V$, $T_A=+25^\circ C$, unless otherwise specified.)

Supply Current vs. Input Voltage

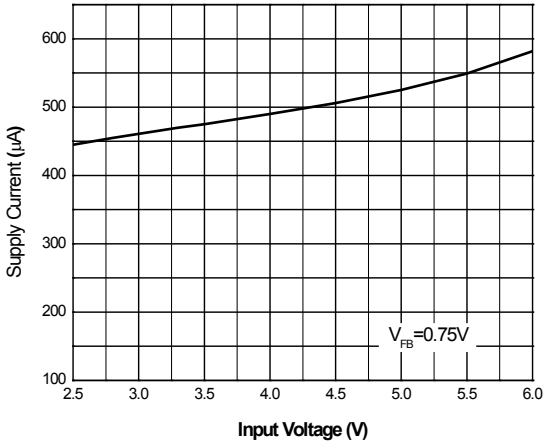

Supply Current vs. Ambient Temperature

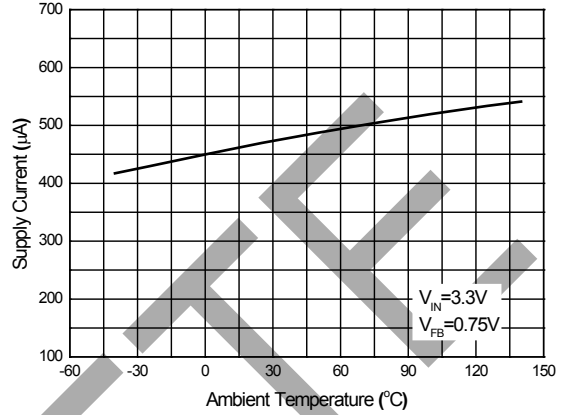

Efficiency vs. Output Current

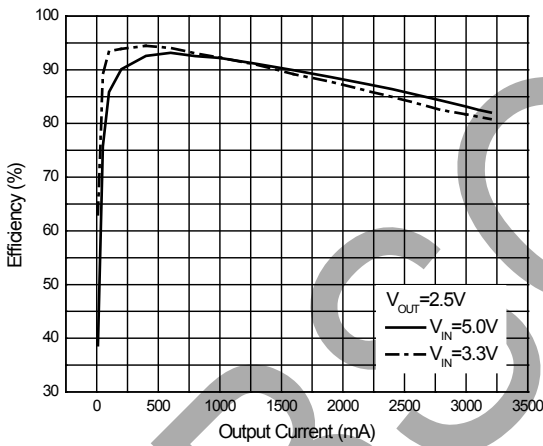

PMOS ON Resistance vs. Ambient Temperature

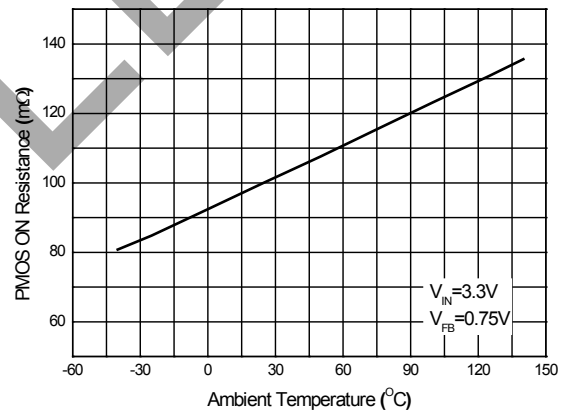

NMOS ON Resistance vs. Ambient Temperature

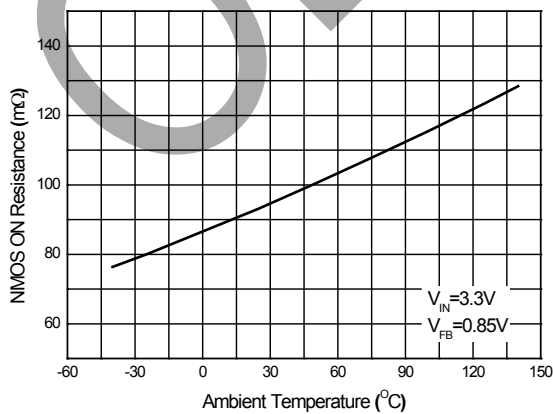

Frequency vs. Ambient Temperature

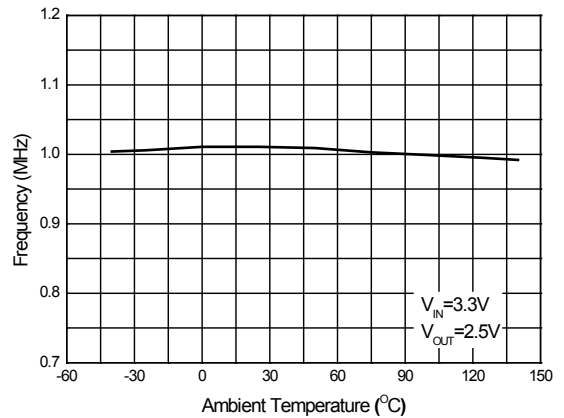

OBSOLETE - PART DISCONTINUED

Performance Characteristics (Cont. $V_{IN}=V_{DD}=V_{PVDD}=3.3V$, $T_A=+25^{\circ}C$, unless otherwise specified.)

V_{FB} vs. Ambient Temperature

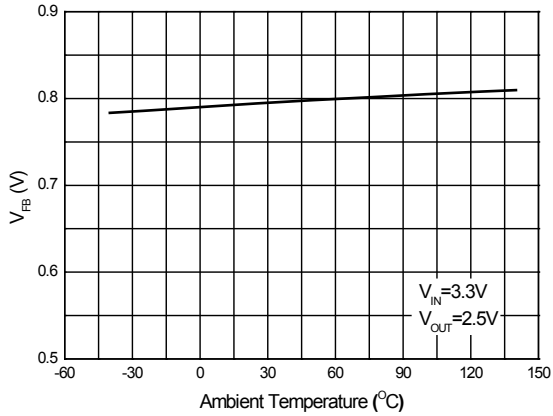

Current Limit vs. Ambient Temperature

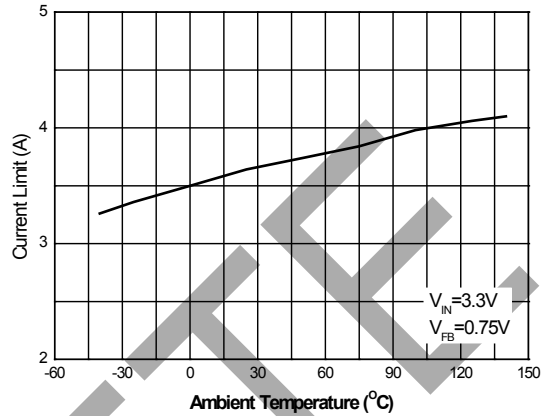

Start-up from V_{IN} ($V_{IN}=3.3V$, $V_{OUT}=2.5V$, $I_{OUT}=3A$)

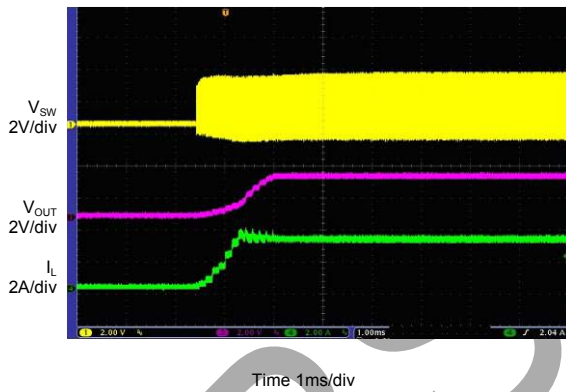

Load Transient Response ($V_{IN}=3.3V$, $V_{OUT}=2.5V$, $I_{OUT}=0.5A$ to $3A$)

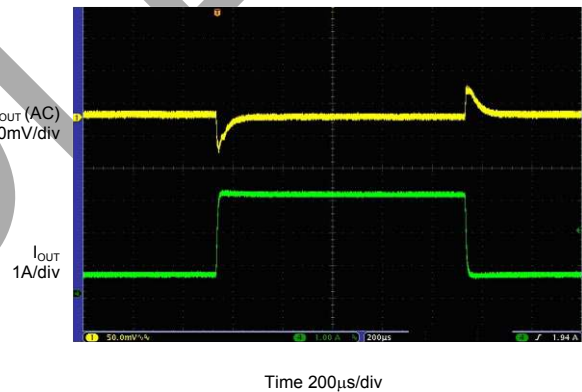

Short Circuit Protection ($V_{IN}=3.3V$, $V_{OUT}=2.5V$)

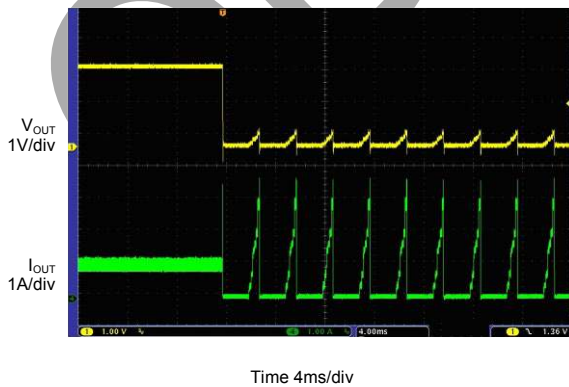

Short Circuit Recovery ($V_{IN}=3.3V$, $V_{OUT}=2.5V$)

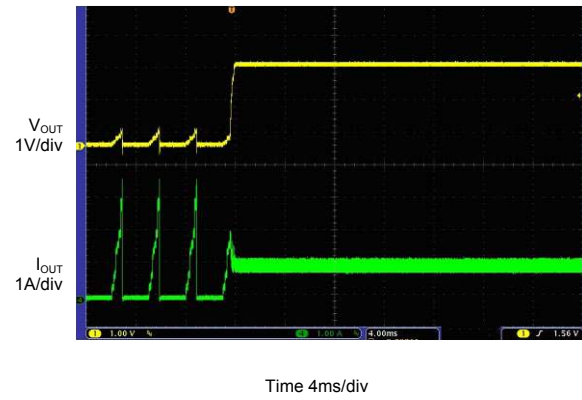

Ordering Information

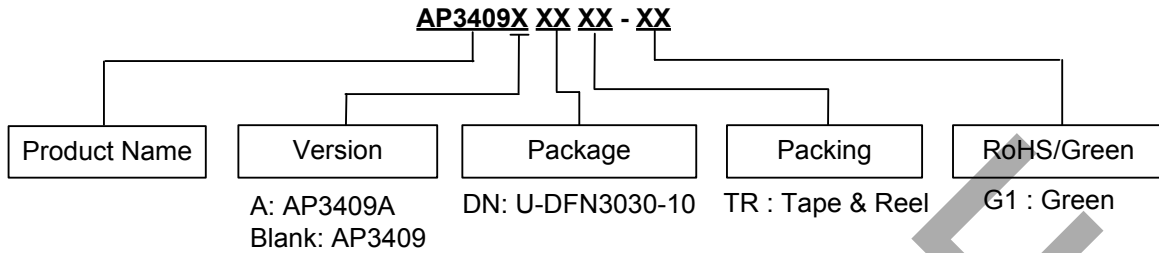

Diodes IC's Pb-free products with "G1" suffix in the part number, are RoHS compliant and green.

Package	Temperature Range	Part Number	Marking ID	Packing
U-DFN3030-10	-40 to +125°C	AP3409DNTR-G1	BDA	5000/Tape & Reel
		AP3409ADNTR-G1	BCA	5000/Tape & Reel

Marking Information

AP3409 (Top View)

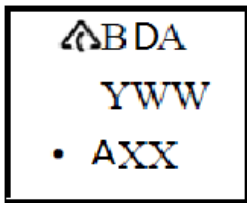

First Line: Logo and Marking ID
 Second and Third Lines: Date Code
 Y: Year
 WW: Work Week of Molding
 A: Assembly House Code
 XX: 7th and 8th Digits of Batch No.

AP3409A (Top View)

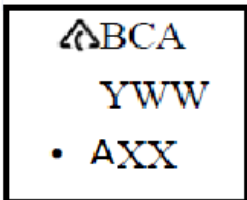

First Line: Logo and Marking ID
 Second and Third Lines: Date Code
 Y: Year
 WW: Work Week of Molding
 A: Assembly House Code
 XX: 7th and 8th Digits of Batch No.

Package Outline Dimensions (All dimensions in mm(inch).)

(1) Package Type: U-DFN3030-10

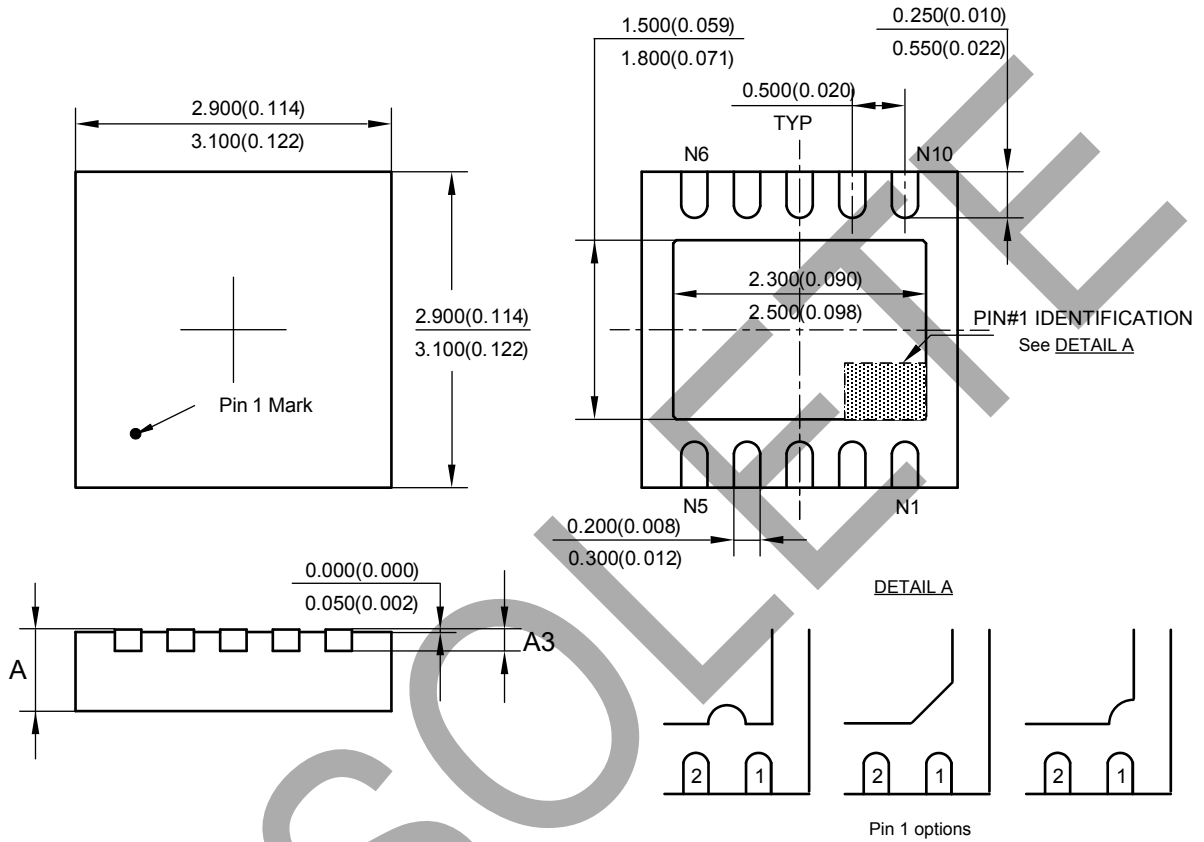

Symbol	A				A3			
	min(mm)	max(mm)	min(inch)	max(inch)	min(mm)	max(mm)	min(inch)	max(inch)
Option 1	0.700	0.800	0.028	0.031	0.153	0.253	0.006	0.010
Option 2	0.570	0.630	0.022	0.025	0.150 (Typ)		0.006 (Typ)	

OBSOLETE - PART DISCONTINUED

OBSOLETE

Suggested Pad Layout

(1) Package Type: U-DFN3030-10

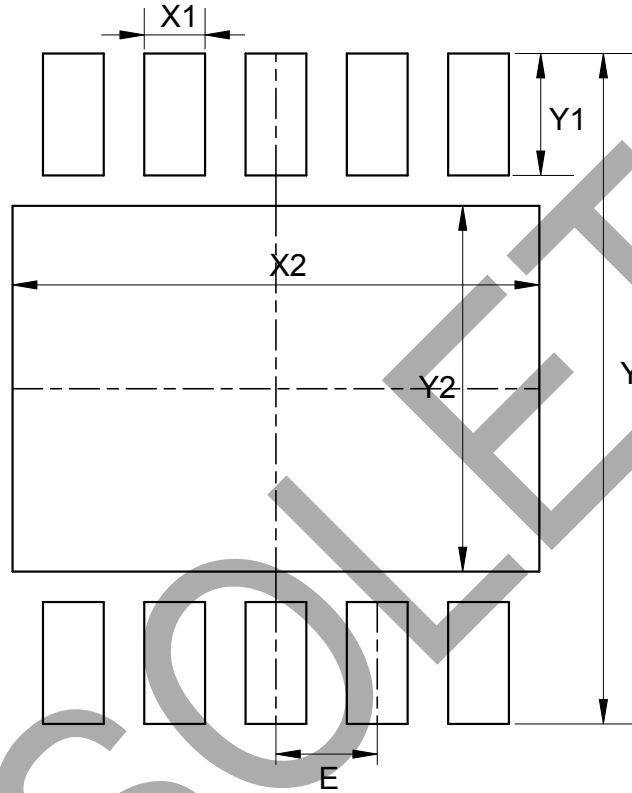

Dimensions	Y (mm)/(inch)	X1 (mm)/(inch)	Y1 (mm)/(inch)	X2 (mm)/(inch)	Y2 (mm)/(inch)	E (mm)/(inch)
Value	3.300/0.130	0.300/0.012	0.600/0.024	2.600/0.102	1.800/0.071	0.500/0.020

IMPORTANT NOTICE

1. DIODES INCORPORATED AND ITS SUBSIDIARIES (“DIODES”) MAKE NO WARRANTY OF ANY KIND, EXPRESS OR IMPLIED, WITH REGARDS TO ANY INFORMATION CONTAINED IN THIS DOCUMENT, INCLUDING, BUT NOT LIMITED TO, THE IMPLIED WARRANTIES OF MERCHANTABILITY, FITNESS FOR A PARTICULAR PURPOSE OR NON-INFRINGEMENT OF THIRD PARTY INTELLECTUAL PROPERTY RIGHTS (AND THEIR EQUIVALENTS UNDER THE LAWS OF ANY JURISDICTION).
2. The Information contained herein is for informational purpose only and is provided only to illustrate the operation of Diodes products described herein and application examples. Diodes does not assume any liability arising out of the application or use of this document or any product described herein. This document is intended for skilled and technically trained engineering customers and users who design with Diodes products. Diodes products may be used to facilitate safety-related applications; however, in all instances customers and users are responsible for (a) selecting the appropriate Diodes products for their applications, (b) evaluating the suitability of the Diodes products for their intended applications, (c) ensuring their applications, which incorporate Diodes products, comply the applicable legal and regulatory requirements as well as safety and functional-safety related standards, and (d) ensuring they design with appropriate safeguards (including testing, validation, quality control techniques, redundancy, malfunction prevention, and appropriate treatment for aging degradation) to minimize the risks associated with their applications.
3. Diodes assumes no liability for any application-related information, support, assistance or feedback that may be provided by Diodes from time to time. Any customer or user of this document or products described herein will assume all risks and liabilities associated with such use, and will hold Diodes and all companies whose products are represented herein or on Diodes’ websites, harmless against all damages and liabilities.
4. Products described herein may be covered by one or more United States, international or foreign patents and pending patent applications. Product names and markings noted herein may also be covered by one or more United States, international or foreign trademarks and trademark applications. Diodes does not convey any license under any of its intellectual property rights or the rights of any third parties (including third parties whose products and services may be described in this document or on Diodes’ website) under this document.
5. Diodes products are provided subject to Diodes’ Standard Terms and Conditions of Sale (<https://www.diodes.com/about/company/terms-and-conditions/terms-and-conditions-of-sales/>) or other applicable terms. This document does not alter or expand the applicable warranties provided by Diodes. Diodes does not warrant or accept any liability whatsoever in respect of any products purchased through unauthorized sales channel.
6. Diodes products and technology may not be used for or incorporated into any products or systems whose manufacture, use or sale is prohibited under any applicable laws and regulations. Should customers or users use Diodes products in contravention of any applicable laws or regulations, or for any unintended or unauthorized application, customers and users will (a) be solely responsible for any damages, losses or penalties arising in connection therewith or as a result thereof, and (b) indemnify and hold Diodes and its representatives and agents harmless against any and all claims, damages, expenses, and attorney fees arising out of, directly or indirectly, any claim relating to any noncompliance with the applicable laws and regulations, as well as any unintended or unauthorized application.
7. While efforts have been made to ensure the information contained in this document is accurate, complete and current, it may contain technical inaccuracies, omissions and typographical errors. Diodes does not warrant that information contained in this document is error-free and Diodes is under no obligation to update or otherwise correct this information. Notwithstanding the foregoing, Diodes reserves the right to make modifications, enhancements, improvements, corrections or other changes without further notice to this document and any product described herein. This document is written in English but may be translated into multiple languages for reference. Only the English version of this document is the final and determinative format released by Diodes.
8. Any unauthorized copying, modification, distribution, transmission, display or other use of this document (or any portion hereof) is prohibited. Diodes assumes no responsibility for any losses incurred by the customers or users or any third parties arising from any such unauthorized use.

Copyright © 2021 Diodes Incorporated

www.diodes.com