

KEYING OPTION E
SHORTING BAR VERSION

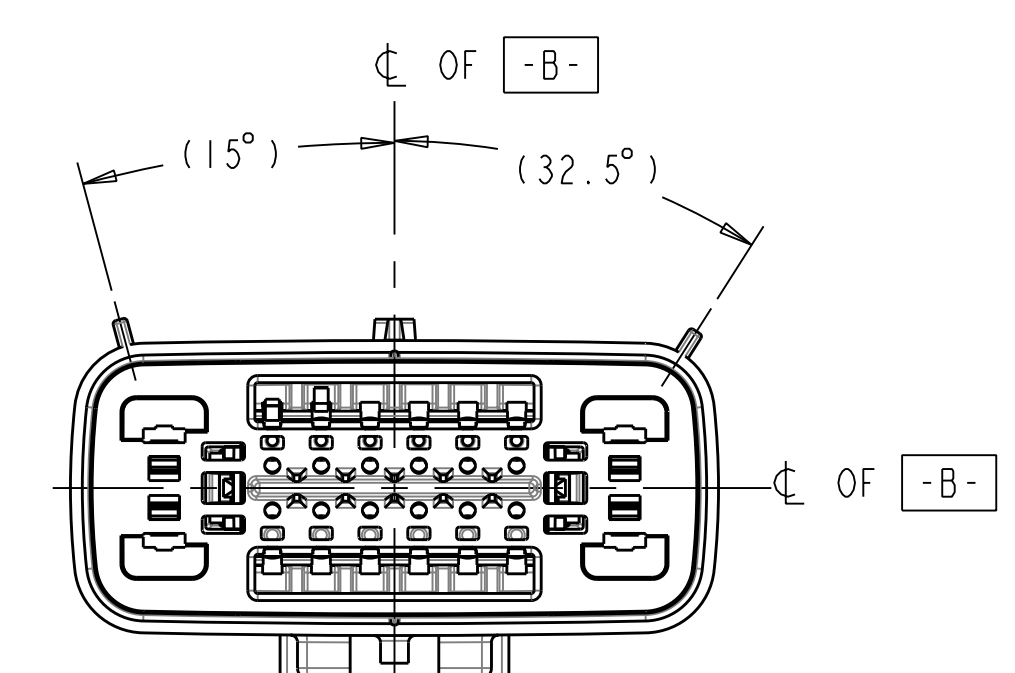

KEYING OPTION F
SHORTING BAR VERSION

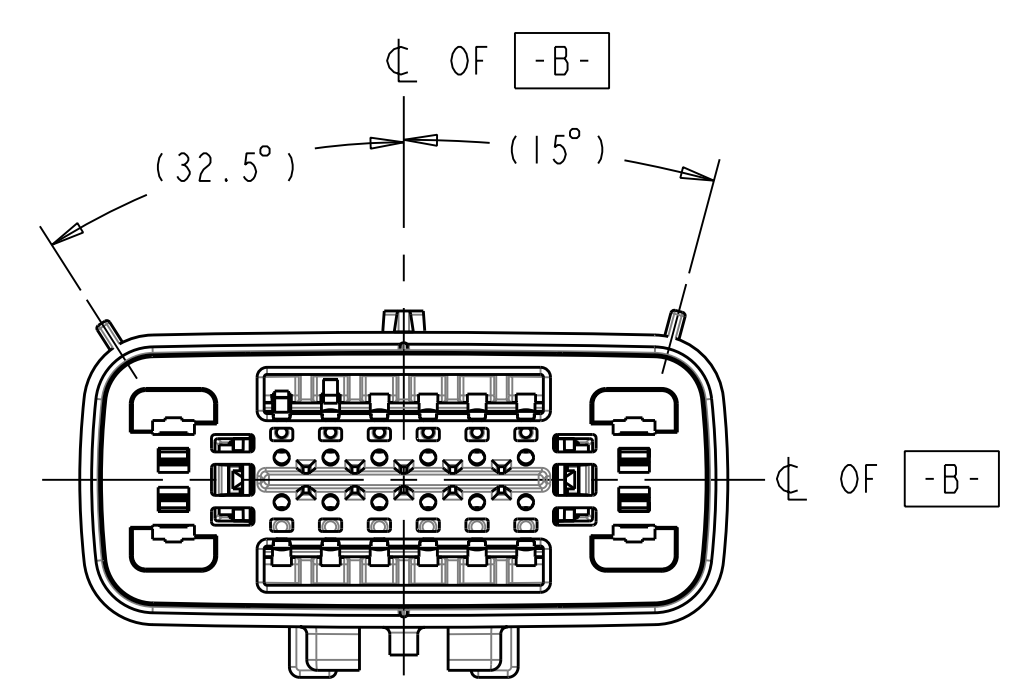

KEYING OPTION G
SHORTING BAR VERSION

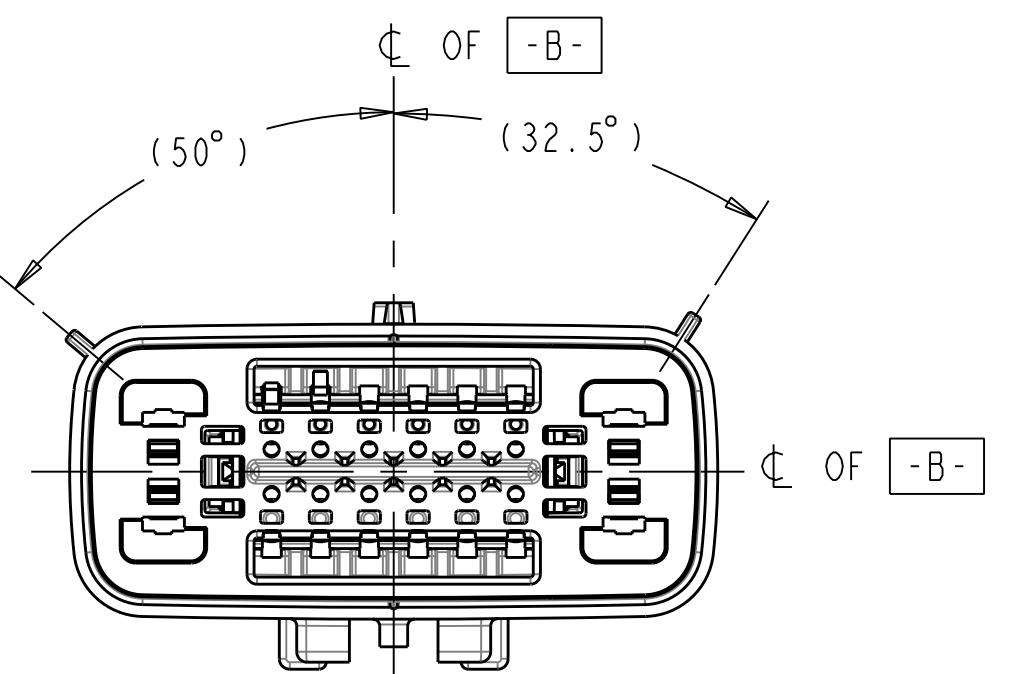

KEYING OPTION H
SHORTING BAR VERSION

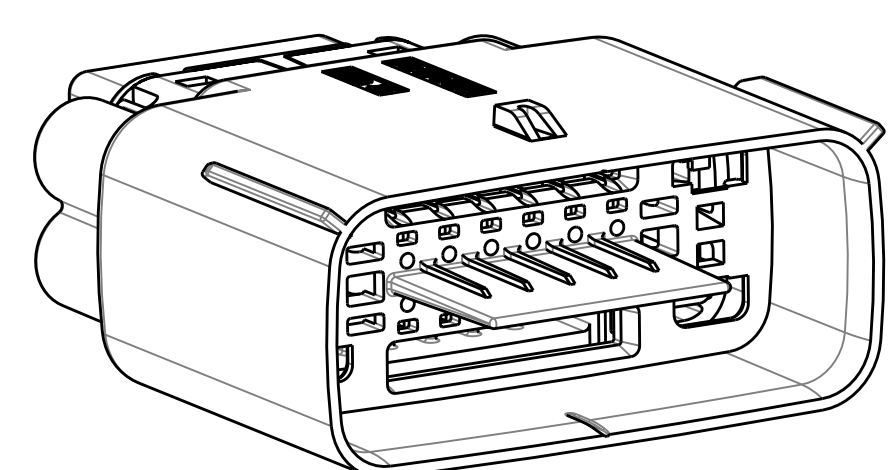

SCALE 2:1

DETAIL A
SCALE 10:1

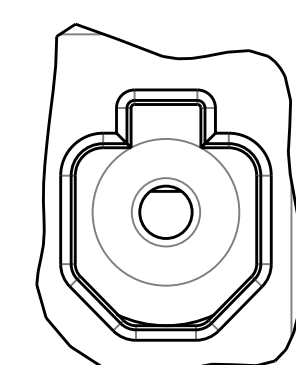

INSERT ONLY BLADE TERMINALS FROM 31296 SERIES (SHORTING BAR BLADE TERMINALS) INTO GROMMET CAP OPENINGS AS SHOWN

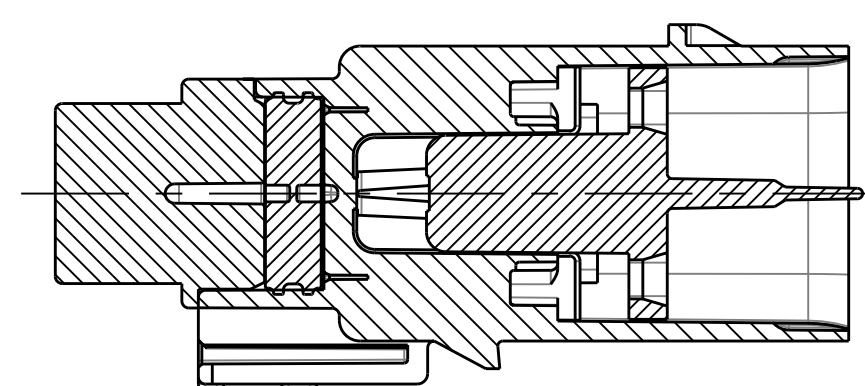

SECTION B-B
(BLADE INSERT SHOWN IN PRE-LOCK POSITION)
SEE NOTE #2

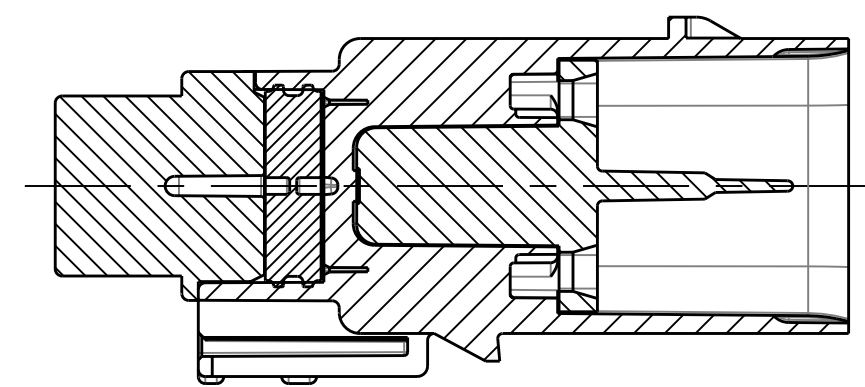

SECTION B-B
(BLADE INSERT SHOWN IN FULL-LOCK POSITION)
SEE NOTE #2

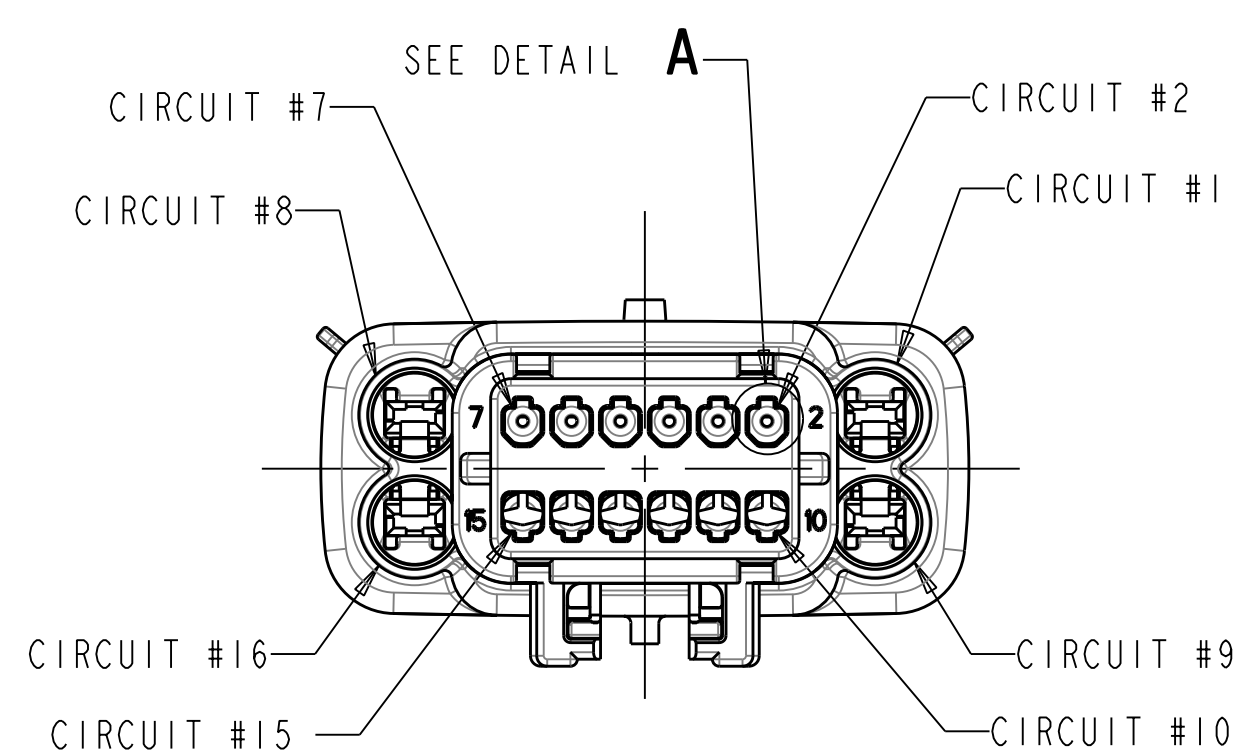

REAR VIEW
(WIRE HARNESS SIDE)

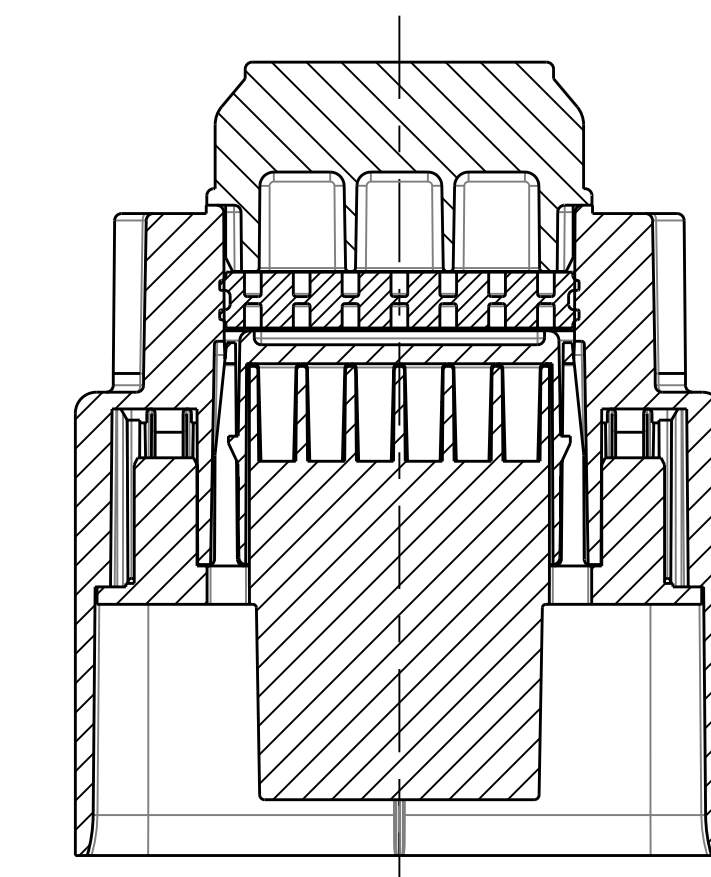

SECTION A-A

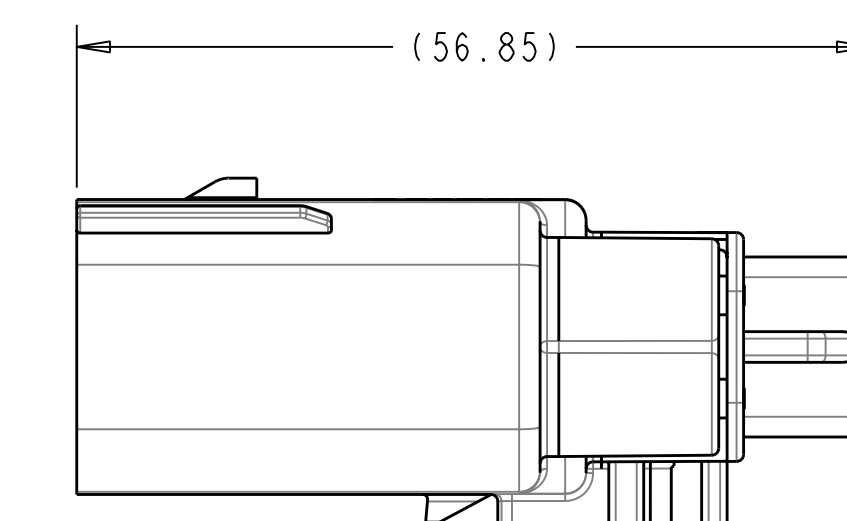
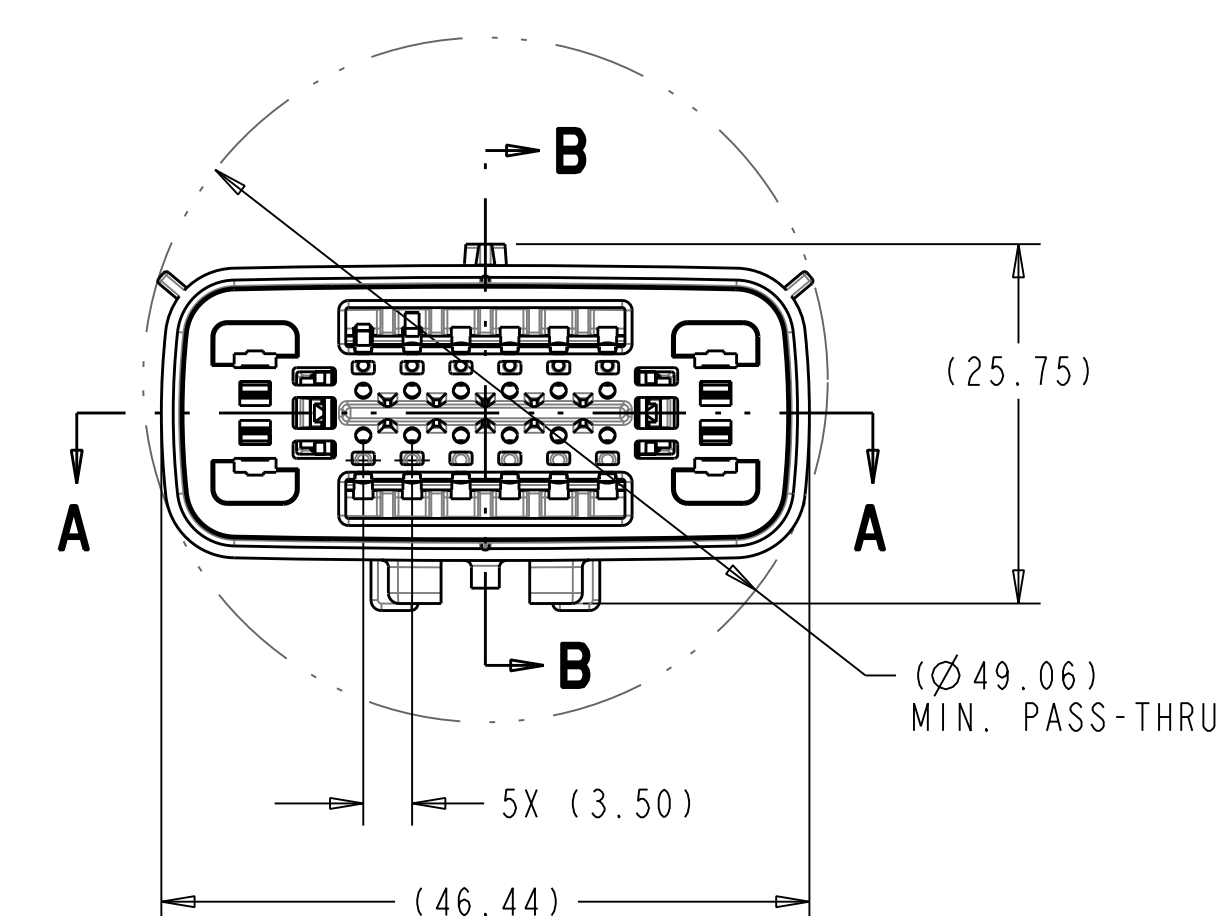

ASSEMBLY, 16-WAY, SHORTING BAR, HYBRID, MALE

NOTES: UNLESS OTHERWISE SPECIFIED

- DESIGNED TO MATE WITH RECEPTACLE HOUSING ASSEMBLY SPECIFIED ON FORD CUSTOMER DRAWING SWTT-14A464-FA (SHORTING BAR VERSION).
- ASSEMBLY SHIPPED WITH BLADE INSERT IN PRE-LOCK POSITION (SEE SECTION B-B PRE-LOCK). UPON FULL TERMINAL ASSEMBLY, EACH BLADE INSERT MUST BE SNAPPED INTO ITS FINAL-LOCK POSITION.
- FOR BLADE TERMINALS TO BE USED WITH THIS ASSEMBLY, SEE TABLE "APPLICABLE COMPONENTS" BELOW.
- DRAWING CONFORMS TO AVP-(T401/T406)-001 REV A DATED 10/1/01.
- PARTS ARE TO BE FREE OF SCRATCHES, DISCOLORATION, CONTAMINATION OR OTHER IMPERFECTIONS THAT MAY AFFECT FUNCTION OR FIT OF PART.
- THE OPERATING ENVIRONMENT CRITERIA FOR THIS CONNECTOR IS TEMPERATURE CLASS 3.
- MAXIMUM INSERTION FORCE TO MATE FULLY POPULATED CONNECTORS WITH TIN TERMINALS TO BE LESS THAN 75N.
- CONFORMS TO SAE/USCAR-2 REV.3 (4/01).
- CONFORMS TO SDS VERSION 11 (DATED 11/08/02).
- 0.3mm MAXIMUM RADIUS PERMISSIBLE ON EDGES AND FILLETS SHOWN AS SHARP.
- MATING PART IS SWTT-14A464-FA. SEE PRINT FOR AVAILABLE CONFIGURATIONS.
- FOR UNUSED 2.8mm CAVITY, USE 2.8mm CAVITY PLUG P/N (97BG-10C930-HA)
- REFER TO FORD CUSTOMER DRAWING 4R3T-14A624-AA FOR NON-SHORTING BAR APPLICATION.
- KEYING OPTION G IS AVAILABLE BUT NOT RELEASED IN THE FORD SYSTEM.
- ALL PLASTIC PARTS MUST HAVE MATERIAL IDENTIFICATION SYMBOLS CLEARLY MARKED, WHEREVER PACKAGE SIZE PERMITS.
- FOR ENGINEERING APPROVED SOURCE SEE ENGINEERING RELEASE.
- ENGINEERING APPROVAL OF SAMPLE FROM EACH SUPPLIER IS REQUIRED PRIOR TO AUTHORIZATION OF PART PRODUCTION.
- CHANGES IN DESIGN COMPOSITION OR PROCESSING FROM THE PART PREVIOUSLY APPROVED FOR PART PRODUCTION REQUIRES PRIOR ENGINEERING APPROVAL.
- SOURCE IDENTIFICATION MARK MUST BE PERMANENTLY APPLIED ON THE PART WITH 1.5mm LETTER SIZE FROM THE BOTTOM TO THE TOP OF THE CHARACTER AND LEGIBLE WHEREVER PACKAGE SIZE PERMITS OR OTHER AGREEMENTS ARE MADE.
- SHORTING BAR TERMINAL CRIMP ANGLE MUST BE BETWEEN -1.4° AND +3.5° AFTER INSTALLATION INTO THE CONNECTOR ASSEMBLY.

LTRS		REVISIONS			
ORIGINATOR	CHECKER	ENGR APP	MATL APP		
A	RELEASED SWTT-14A624-FA ARCHIVE DATE AE00-1-11455846-000	030326	CAD: Y		
ROONEY	VINODH	METZ			
B	RELEASED SWTT-14A624-FA VIEW DETAIL "A" ADDED FOR SHORTING BAR BLADE TERMINALS. ADDED ROWS AND COLUMNS TO APPLICABLE COMPONENTS FOR MOLEX P/N'S 31296-0004 AND 31296-0006. ARCHIVE DATE AE00-E-11427227-006	030701	CAD: Y		
GRIFFITHS	VINODH	METZ			
C	C1 ADDED CONFIG. FOR FORD SUFFIX: -000 AND MOLEX P/N 33486-1721 -001 AND MOLEX P/N 33486-1722 -002 AND MOLEX P/N 33486-1723 -003 AND MOLEX P/N 33486-1724 -004 AND MOLEX P/N 33486-1725 -005 AND MOLEX P/N 33486-1726 -006 AND MOLEX P/N 33486-1727 -007 AND MOLEX P/N 33486-1728 -000 AND MOLEX P/N 33486-1731 -001 AND MOLEX P/N 33486-1729 RELEASED SWTT-14A624-HA/KA ARCHIVE DATE AE00-1-11536601-000	030827	CAD: Y		
GRIFFITHS	BUTCHER	METZ			
D	D1 ADDED CONFIG. FOR FORD SUFFIX: -000 AND MOLEX P/N 33486-1701 -001 AND MOLEX P/N 33486-1733 -001 AND MOLEX P/N 33486-1739 -002 AND MOLEX P/N 33486-1740 -003 AND MOLEX P/N 33486-1741 -004 AND MOLEX P/N 33486-1742 D2 NOTE #11 SWTT-14A464-FA WAS 4R3T-14A464-BA D3 NOTE #14 - KEYING OPTIONS "G AND H" WAS "F,G, AND H" RELEASED 6E5T-14A624-CA/DA ARCHIVE DATE AE00-E-11505652-037	040210	CAD: Y		
GRIFFITHS	BUTCHER	METZ			
E	E1 ADDED CONFIG. FOR FORD SUFFIX: -005 AND MOLEX P/N 33486-1753 RELEASED 6E5T-14A624-CA/DA ARCHIVE DATE AE00-E-11427227-040	040224	CAD: Y		
GRIFFITHS	BUTCHER	METZ			
F	F1 SWTT-14A624-FB WAS SWTT-14A624-FA, SWTT-14A624-HB WAS SWTT-14A624-HA, SWTT-14A624-KB WAS SWTT-14A624-KA, F2 ADDED RADIUS TO CLIPSLOT SHARKFIN, CLIPSLOT EXTERNAL RIB THICKNESS DOUBLED RELEASED SWTT-14A624-FB/HB/KB/ ARCHIVE DATE AE00-E-11619715-000	040406	CAD: Y		
GRIFFITHS	BUTCHER	METZ			
G	G1 ADDED CONFIG. FOR FORD SUFFIX: -000 AND MOLEX P/N 33486-1760 -001 AND MOLEX P/N 33486-1759 RELEASED SWTT-14A624-JA/ ARCHIVE DATE AE00-E-11614819-003	040511	CAD: Y		
GRIFFITHS	BUTCHER	MLOTKIEWICZ			
H	H1 6E5T-14A624-CB WAS 6E5T-14A624-CA, 6E5T-14A624-DB WAS 6E5T-14A624-DA, UPDATED NOTES H2 ADDED CONFIG. FOR FORD SUFFIX: -008 AND MOLEX P/N 33486-1761 -009 AND MOLEX P/N 33486-1764 -010 AND MOLEX P/N 33486-1765 5L8T-14A624-HA: -000 AND MOLEX P/N 33486-1762 -001 AND MOLEX P/N 33486-1763 -002 AND MOLEX P/N 33486-1766 -003 AND MOLEX P/N 33486-1767 RELEASED SWTT-14A624-FB/ 6E5T-14A624-CB/DB/ 5L8T-14A624-HA ARCHIVE DATE MLOO-E-11605364-002	040630	CAD: Y		
GRIFFITHS	BUTCHER				
J	J1 ADDED NOTE #20 RELEASED SWTT-14A4624-FB/HB/KB, RELEASED 6E5T-14A4624-CB/DB/ RELEASED SWTT-14A4624-JA RELEASED 5L8T-14A4624-HA ARCHIVE DATE AE00-E-11685473-001	040816	CAD: Y		
GRIFFITHS	BUTCHER				

APPLICABLE COMPONENTS						
DESCRIPTION	NOMINAL TERMINAL SIZE	FORD PART NUMBER	MOLEX PART NUMBER	MATERIAL/SPECIFICATION NUMBER	WIRE S.A.E. (MIL-123A)	WIRE METRIC
TERMINAL-MALE (SN)	1.5 (MX150)	2L1T-14421-CA	33000-0002	COPPER ALLOY/TIN PLATE	16, 18, 20	TBD
TERMINAL-MALE (SN)	1.5 (MX150)	2L1T-14421-BA	33000-0003	COPPER ALLOY/TIN PLATE	22	TBD
TERMINAL-MALE (AU)	1.5 (MX150)	2L1T-14421-FA	33011-0004	COPPER ALLOY/GOLD PLATE	16, 18, 20	TBD
TERMINAL-MALE (AU)	1.5 (MX150)	2L1T-14421-EA	33011-0006	COPPER ALLOY/GOLD PLATE	22	TBD
TERMINAL-MALE (AU)	1.5 (MX150)	4F9T-14421-AA	31296-0004	COPPER ALLOY/GOLD PLATE	18, 20	TBD
TERMINAL-MALE (AU)	1.5 (MX150)	4F9T-14421-BA	31296-0006	COPPER ALLOY/GOLD PLATE	22	TBD
TERMINAL-MALE (SN)	TYCO 2.8mm CABLE SEAL TERMINAL	3F2T-14421-GA	N/A	NOT SUPPLIED BY MOLEX	12	TBD
TERMINAL-MALE (SN)	TYCO 2.8mm CABLE SEAL TERMINAL	1FIT-14421-JA	N/A	NOT SUPPLIED BY MOLEX	14	TBD
TERMINAL-MALE (SN)	TYCO 2.8mm CABLE SEAL TERMINAL	1FIT-14421-HA	N/A	NOT SUPPLIED BY MOLEX	16	TBD
TERMINAL-MALE (SN)	TYCO 2.8mm CABLE SEAL TERMINAL	1FIT-14421-GA	N/A	NOT SUPPLIED BY MOLEX	18	TBD
TERMINAL-MALE (SN)	TYCO 2.8mm CABLE SEAL TERMINAL	1FIT-14421-FA	N/A	NOT SUPPLIED BY MOLEX	20	TBD
TERMINAL-MALE (SN)	TYCO 2.8mm CABLE SEAL TERMINAL	1FIT-14421-EA	N/A	NOT SUPPLIED BY MOLEX	22	TBD
SEAL PLUG	YAZAKI 2.8mm CABLE SEAL PLUG	97BG-10C930-HA	N/A	NOT SUPPLIED BY MOLEX	N/A	N/A

FORD MOLEX PART NO. CROSS REFERENCE (ASSEMBLY)																			
FORD P/N	FORD SUFFIX	MOLEX P/N	KEYING OPTION	COLOR	X= PLUGGED CIRCUIT POSITIONS, SB = SHORTING BAR														
					2	3	4	5	6	7	10	11	12	13	14	15			
SWTT-14A624-FB	-000	33486-1714	E	BLACK			SB	SB											
SWTT-14A624-HB	-000	33486-1721	F	GRAY	X	X	SB	SB	X	X					X	X	X		
SWTT-14A624-HB	-001	33486-1722	F	GRAY			SB	SB	X										
SWTT-14A624-HB	-002	33486-1723	F	GRAY	X	X	SB	SB	X						X				
SWTT-14A624-HB	-003	33486-1724	F	GRAY			SB	SB	X						X				
SWTT-14A624-HB	-004	33486-1725	F	GRAY	X		SB	SB	X	X	X	X							
SWTT-14A624-HB	-005	33486-1726	F	GRAY			SB	SB	X				X		X				
SWTT-14A624-HB	-006	33486-1727	F	GRAY			SB	SB					X						
SWTT-14A624-HB	-007	33486-1728	F	GRAY	X	X	SB	SB	X	X			X						
SWTT-14A624-HB	-008	33486-1761	F	GRAY			SB	SB						X	X	X			
SWTT-14A624-HB	-009	33486-1764	F	GRAY			SB	SB	X	X	X	X	X	X	X	X			
SWTT-14A624-HB	-010	33486-1765	F	GRAY			SB	SB	X	X	X	X	X	X	X	X			
SWTT-14A624-KB	-000	33486-1731	F	GRAY			SB	SB											
SWTT-14A624-KB	-001	33486-1729	F	GRAY	X	X	X	X	X										
6E5T-14A624-CB	-000	33486-1701	E	BLACK			SB	SB						SB	SB				
6E5T-14A624-DB	-000	33486-1733	E	BLACK			SB	SB	SB	SB				SB	SB	SB	SB		
6E5T-14A624-CB	-001	33486-1739	E	BLACK			SB	SB			X	X	SB	SB	SB	X			
6E5T-14A624-CB	-002	33486-1740	E	BLACK			SB	SB	X	X	X	X	SB	SB	SB	X			
6E5T-14A624-CB	-003	33486-1741	E	BLACK			SB	SB					SB	SB	X	X			
6E5T-14A624-CB	-004	33486-1742	E	BLACK			SB	SB					SB	SB	X				
6E5T-14A624-CB	-005	33486-1753	E	BLACK	X		SB	SB					SB	SB		X			
SWTT-14A624-JA	-000	33486-1760	E	BLACK			SB	SB	SB	SB				SB	SB				
SWTT-14A624-JA	-001	33486-1759	E	BLACK	X	X	SB	SB	SB	SB				SB	SB	X	X		
5L8T-14A624-HA	-000	33486-1762	H	YELLOW			SB	SB						SB	SB				
5L8T-14A624-HA	-001	33486-1763	H	YELLOW			SB	SB						SB	SB	X			
5L8T-14A624-HA	-002	33486-1766	H	YELLOW			SB	SB	X	X	X	X	SB	SB	X				
5L8T-14A624-HA	-003	33486-1767	H	YELLOW			SB	SB	X		X	X	SB	SB	X				

PART NUMBERS		REFERENCE FOR INFORMATION CONTACT MOLEX, INC. 7331	
SWTT-14A624-FB		PART MUST COMPLY WITH MATERIAL SPECIFICATION HSS-H999999-91 TO HELP SAFEGUARD HEALTH, SAFETY AND THE ENVIRONMENT.	
SWTT-14A624-HB		DRAFTED IN ACCORDANCE WITH FAD ENGINEERING DRAFTING STANDARD IN CURRENT AT INITIAL RELEASE	
SWTT-14A624-KB		3RD ANGLE PROJ DIMENSIONS IN MILLIMETERS	
6E5T-14A624-CB		CAD TYPE X-PROE	CAD LOC. CAD FILE IS MASTER
6E5T-14A624-DB		OPER. NO.	UNIT DRAWING
SWTT-14A624-JA		DESIGN DHG	DETAIL JBR
5L8T-14A624-HA		CHECKED	SAFETY
		SCALE 2:1	DATE 03/3/26
		DIVISION PLANT	TITLE SLEEVE ASSEMBLY WIRE CONNECTOR MALE
			SH T OF I

DRW SIZE A0/E

TABLE OF CONTENTS

SHEET NO.	SHEET DESCRIPTION
1	NOTES
2	KEY CONFIGURATIONS
3	BLADE SEALED ASSEMBLY
4	SYSTEM PACKAGING
5-9	BOM

NOTES: VALID UNLESS OTHERWISE SPECIFIED

1. GENERAL:
 a. APPLICATION SPECIFICATION SEE: AS-33472-100
 CONTAINS: PRODUCT INTRODUCTION, PRODUCT SUMMARY, CONNECTOR ASSEMBLY, PACKAGING INFORMATION, CONNECTOR MATING, SERVICE INSTRUCTIONS, ELECTRICAL CONTINUITY CHECKING, CRIMPING, AND TROUBLESHOOTING.
 -DESIGNED TO MATE WITH RECEPTACLE SEALED ASSEMBLY SPECIFIED IN MOLEX DRAWING SD-33476-161 AND SD-33476-161 FOR SHORTING BAR APPLICATIONS RECEPTACLE SEALED ASSEMBLY CONFIGURATION MUST CONTAIN A PLR WITH SHORTING BAR LIFTER.
 -FOR 15mm BLADE TERMINALS TO BE USED WITH THE SHORTING BAR CIRCUIT LOCATIONS SEE MOLEX DRAWING SD-31296-001.
 -SHORTING BAR TERMINALS TO BE USED WITH WIRE WITHIN DIAMETER RANGE OF 1.7mm TO 2.06mm.
 -SHORTING BAR TERMINAL CRIMP ANGLE MUST BE BETWEEN -14 DEG. AND +35 DEG. AFTER INSTALLATION INTO THE CONNECTOR ASSEMBLY. REFER TO MOLEX DRAWING SD-31296-001 FOR DETAILS.
 -FOR 15mm BLADE TERMINALS TO BE USED WITH THE NON-SHORTING BAR CIRCUIT LOCATIONS SEE MOLEX DRAWING SD-33000-004.
 -NON-SHORTING BAR TERMINALS TO BE USED WITH WIRE WITHIN DIAMETER RANGE OF 1.4mm TO 2.69mm.
 -FOR 2.8mm BLADE TERMINALS TO BE USED WITH THIS ASSEMBLY SEE TABLE.
 -2.8mm TERMINALS TO BE USED WITH WIRE WITHIN DIAMETER RANGE OF 150mm TO 330mm.
 -ASSEMBLY SHIPPED WITH PLR IN PRE-LOCK POSITION
 -IN THE EVENT THAT THE PLR IS FOUND IN THE SEATED (FINAL LOCK) POSITION, REFER TO MOLEX SPECIFICATION PS-34666-001, AVAILABLE AT www.molex.com OR <http://www.molex.com>
 -ASSEMBLY CONFORMS TO SAE/USCAR-2 REV.4 WITH THE FOLLOWING EXCEPTIONS:
 -TERMINAL INSERTION FORCE FOR WIRE DIAMETER ABOVE 25mm NOT EXCEEDING 2.69mm SHALL EXCEED 5 NEWTONS.
 -PLR REMOVAL FROM FINAL-LOCK TO PRE-LOCK SHALL NOT EXCEED 75 NEWTONS.

b. PRODUCT SPECIFICATION SEE: PS-33476-000
 CONTAINS: PRODUCT INTRODUCTION, PRODUCT SUMMARY, RATINGS (CURRENT, TEMPERATURE, SEALING, AND FLAMMABILITY), AND PRODUCT VALIDATION.

c. PARTS IDENTIFICATION PER MOLEX DRAWING PK-31300-514
 d. PARTS MUST BE IN COMPLIANCE TO MOLEX CHEMICAL SUBSTANCES FOR PRODUCTION AND PACKAGING SPECIFICATION: ES-40000-5016
 e. DATA MUST BE SUBMITTED UNDER THE MOLEX PART NUMBER TO IMDS (COMPANY ID#13255)

2. DESIGN - MATERIALS:
 a. CONNECTOR HOUSING, GROMMET CAP, PLR: SPS/NYLON BLEND 20% GLASS FILLED
 b. MAT SEAL: INHERENTLY LUBRICATED SILICONE
 c. SHORTING BARS: STAINLESS STEEL

3. DESIGN - GEOMETRY:
 a. THIS IS A 100% CAD GENERATED PART, THE CAD MATHEMATICAL DATA IS THE MASTER FOR THIS PART, FOR DIMENSIONAL OR ANY INFORMATION NOT SHOWN ON THIS DRAWING, ANALYZE THE CAD MODEL.
 b. GEOMETRIC DIMENSIONS AND TOLERANCES PER ASME Y14.5M - 1994 EDGES AND UNDERMENSIONED DETAILS PER ISO15715 CORNERS SHOWN AS SHARP TO BE 0.2 MAX.
 LETTERING SHALL BE 0.15 MAX RAISED IN 0.25 MAX RECESS PAD.
 THIS INCLUDES RECYCLING CODE, CAVITY ID, VENDOR IDENTIFICATION, AND CUSTOMER MATERIAL NUMBER.
 f. VISUAL DEFECTS SHALL MEET COSMETIC STANDARD PS-45499-002 (Class B)
 g. LASER MARKING: TBD

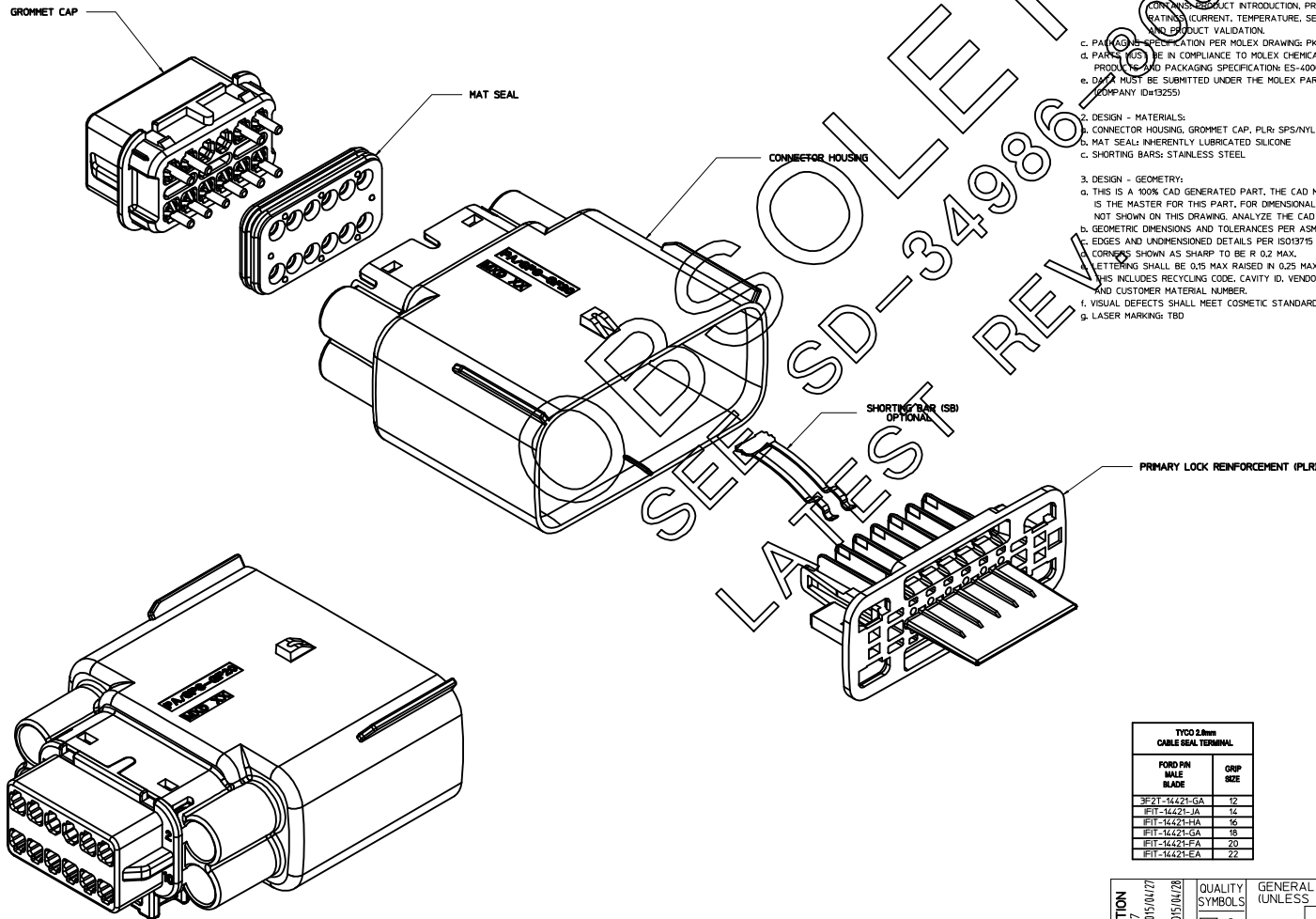

TYCO 2.8mm CABLE SEAL TERMINAL		
FORD P/N	MALE BLADE	GRP SIZE
3P2T-1421-GA	12	
3P2T-1421-MA	14	
3P2T-1421-HA	16	
3P2T-1421-GA	18	
3P2T-1421-FA	20	
3P2T-1421-EA	22	

INSPECTION NUMBER LOG
 LAST NUMBER USED:
 ADDED:
 REMOVED:

CJ	OBSOLETE DRAWING
CH	ADD NEW P/N 33486-2047 THRU 33486-2103
CG	UPDATED STATUS AND COMMENTS COLUMNS
CF	ADD NEW P/N 33486-2045 33486-2046
	ADD NEW P/N 33486-2039 33486-2040
CE	33486-2041 33486-2044
	33486-2043 33486-2044
CC	ADD NEW P/N 33486-2036 33486-2037
	ADD NEW P/N 33486-2033 33486-2034
CB	33486-2035
CA	RE-FORMATTED BOM TABLES
B23	ADD NEW P/N 33486-2030 33486-2031
	33486-2032
B22	ADD NEW P/N 33486-2029
B21	UPDATED DIMENSIONS TO MATCH MODEL
BZ	ADD NEW P/N 33486-2027 33486-2028
BY	ADD NEW P/N 33486-2025 33486-2026
	ADD NEW P/N 33486-2019 33486-2020
BX	33486-2021 33486-2022
	33486-2023 33486-2024
BW	REWORK
REV	DESCRIPTION
SCALE	4:1
DESIGN UNITS	METRIC
THIRD ANGLE	PROJECTION

ENTER DESCRIPTION	QUALITY SYMBOLS	GENERAL TOLERANCES (UNLESS SPECIFIED)		DIMENSION STYLE	
		mm	INCH	MM ONLY	DATE
4 PLACES ±	▽=0	±	---	JWESLEY	06-16-02
3 PLACES ±	▽=0	±	---	CHECKED BY	DATE
2 PLACES ±0.10	▽=0	±	---	DGRIFFITHS	07-09-02
1 PLACE ±0.3	▽=0	±	---	APPROVED BY	DATE
0 PLACE ±	▽=0	±	---	WKOSHY	2010/12/08
DRAFT WHERE APPLICABLE MUST REMAIN WITHIN DIMENSIONS		ANGULAR ± 3 °		MATERIAL NO.	
SEE BOM		SIZE		DOCUMENT NO.	

SD-33486-161	SHEET NO. OF 9
THIS DRAWING CONTAINS INFORMATION THAT IS PROPRIETARY TO MOLEX INCORPORATED AND SHOULD NOT BE USED WITHOUT WRITTEN PERMISSION	
molex	

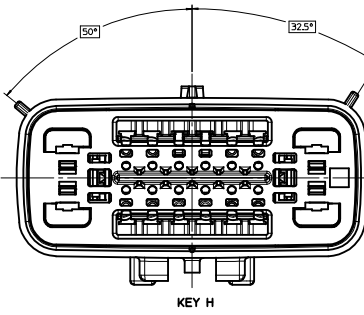
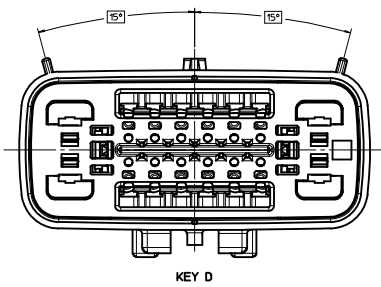
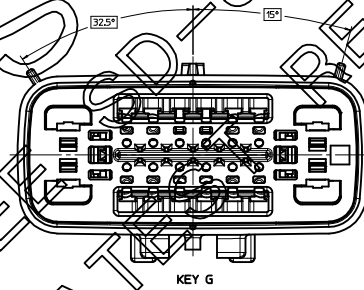
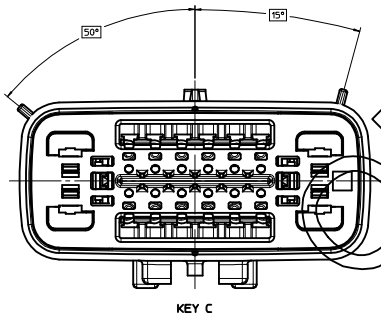
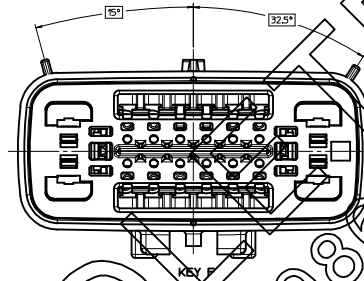
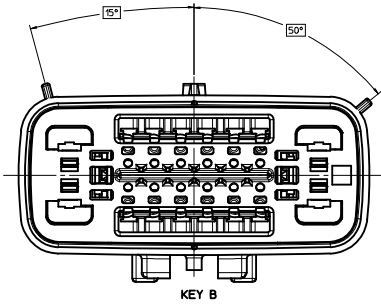
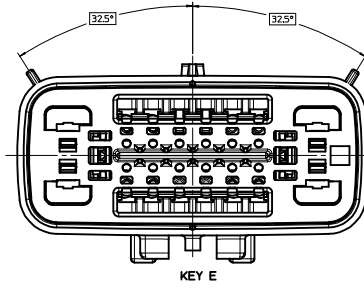
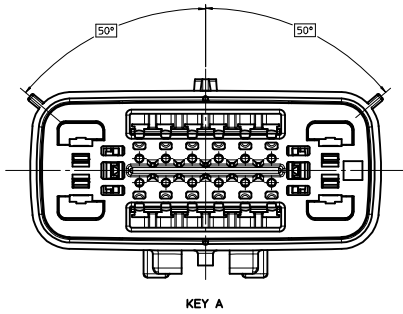

BSO 34986-8001,
 LATEST REV.

ENTER DESCRIPTION EC NO: UAU205-467 DRAWN BY: JMWESLEY 2015/04/27 CHECKED BY: DGRIFITHS APPROVED BY: VKOSHY APPR: WOSHY 2015/04/28	QUALITY SYMBOLS ▽=0 ▽=0 ▽=0	GENERAL TOLERANCES (UNLESS SPECIFIED) <table border="1"> <thead> <tr> <th></th> <th>mm</th> <th>INCH</th> </tr> </thead> <tbody> <tr> <td>4 PLACES</td> <td>± .10</td> <td>± .004</td> </tr> <tr> <td>3 PLACES</td> <td>± .15</td> <td>± .006</td> </tr> <tr> <td>2 PLACES</td> <td>± 0.30</td> <td>± .012</td> </tr> <tr> <td>1 PLACE</td> <td>± 0.50</td> <td>± .020</td> </tr> <tr> <td>0 PLACE</td> <td>± .75</td> <td>± .030</td> </tr> </tbody> </table>		mm	INCH	4 PLACES	± .10	± .004	3 PLACES	± .15	± .006	2 PLACES	± 0.30	± .012	1 PLACE	± 0.50	± .020	0 PLACE	± .75	± .030	DIMENSION STYLE MM ONLY	SCALE 4:1	DESIGN UNITS METRIC	THIRD ANGLE PROJECTION
		mm	INCH																					
	4 PLACES	± .10	± .004																					
	3 PLACES	± .15	± .006																					
2 PLACES	± 0.30	± .012																						
1 PLACE	± 0.50	± .020																						
0 PLACE	± .75	± .030																						
DRAWN BY: JMWESLEY DATE: 06-16-02	CHECKED BY: DGRIFITHS DATE: 07-09-02	APPROVED BY: VKOSHY DATE: 2010/12/08	MATERIAL NO.	DOCUMENT NO.	TITLE MX150 16 WAY HYBRID BLADE SEALED ASSEMBLY	SHEET NO. 2 OF 9																		
ANGULAR ± 3° DRAFT WHERE APPLICABLE MUST REMAIN WITHIN DIMENSIONS	SEE BOM	SD-33486-161	molex																					
THIS DRAWING CONTAINS INFORMATION THAT IS PROPRIETARY TO MOLEX INCORPORATED AND SHOULD NOT BE USED WITHOUT WRITTEN PERMISSION																								

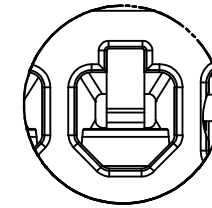
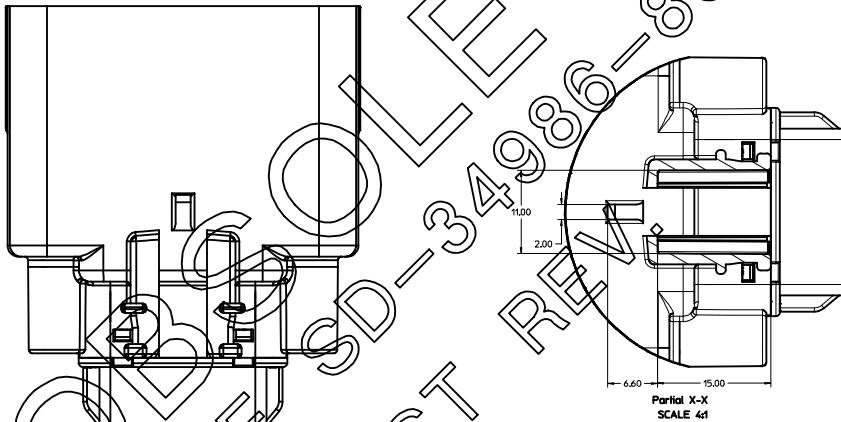
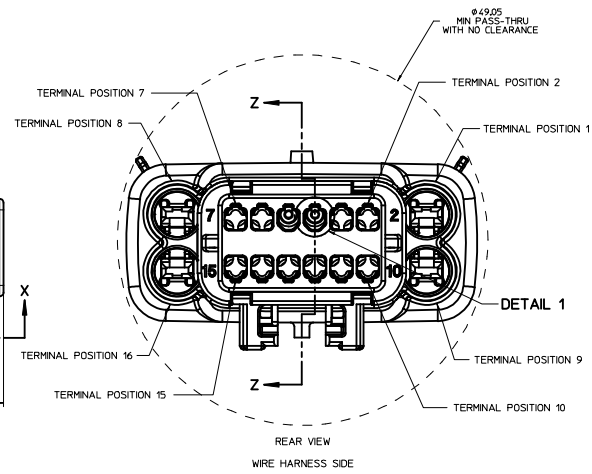
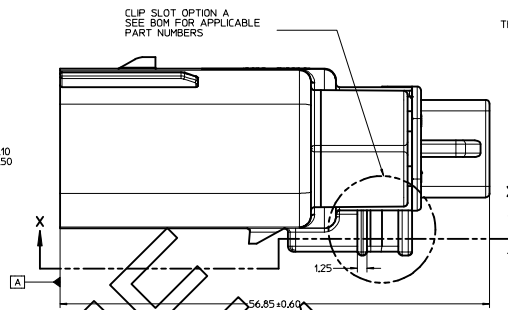
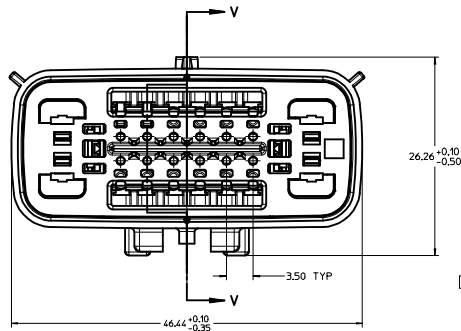
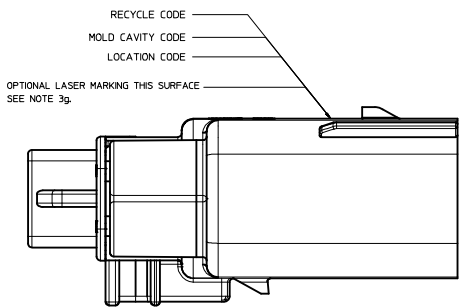

DETAIL 1
SCALE 20:1

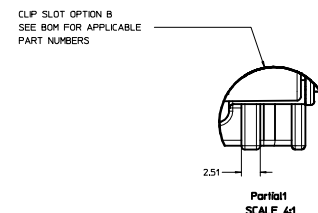
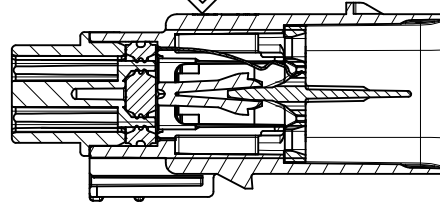
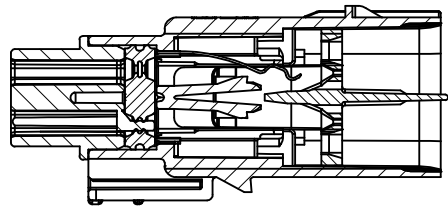

ENTER DESCRIPTION EC NO. UAU2015-167 DRAWING/REVIT 2015/04/27 APPR. WOSNY REV. 2015/04/28	QUALITY SYMBOLS	GENERAL TOLERANCES (UNLESS SPECIFIED)	DIMENSION STYLE	SCALE	DESIGN UNITS	THIRD ANGLE PROJECTION
	▽=0	mm INCH	MM ONLY	4:1	METRIC	☉
	▽=0	4 PLACES ± --- ± ---	DRAWN BY DATE	JWESLEY 06-16-02	TITLE	MX150 16 WAY HYBRID BLADE SEALED ASSEMBLY
	▽=0	3 PLACES ± --- ± ---	CHECKED BY DATE	DGRIFITHS 07-09-02	MATERIAL NO.	SD-33486-161
	2 PLACES ± 0.10 ± ---	APPROVED BY DATE	WKOSHY 2010/12/08	DOCUMENT NO.	SD-33486-161	SHEET NO. 3 OF 9
	1 PLACE ± 0.3 ± ---					
	0 PLACE ±					
	ANGULAR ± 3°	DRAFT WHERE APPLICABLE MUST REMAIN WITHIN DIMENSIONS	SEE BOM			

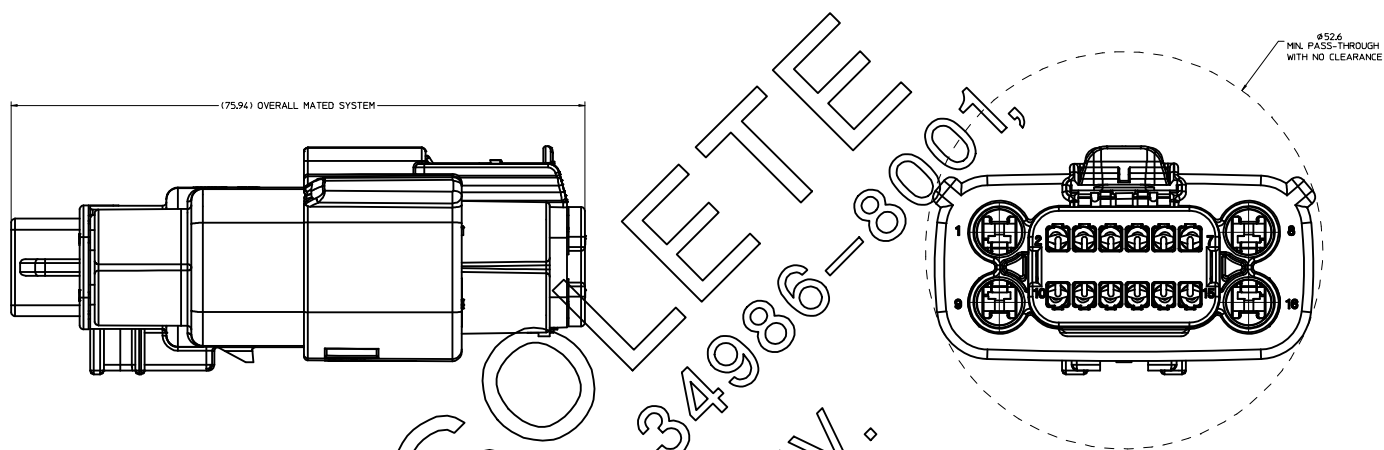

OBSOLETE
SEE SD-34986-8001
LATEST REV.

ENTER DESCRIPTION EC NO: UAU205-167 DRAWN BY: JMWESLEY 2015/04/27 APPR: WOSHY 2015/04/28 REV:	QUALITY SYMBOLS ▽=0 ▽=0 ▽=0	GENERAL TOLERANCES (UNLESS SPECIFIED) <table border="1"> <thead> <tr> <th></th> <th>mm</th> <th>INCH</th> </tr> </thead> <tbody> <tr> <td>4 PLACES</td> <td>± .10</td> <td>± .004</td> </tr> <tr> <td>3 PLACES</td> <td>± .15</td> <td>± .006</td> </tr> <tr> <td>2 PLACES</td> <td>± 0.30</td> <td>± .012</td> </tr> <tr> <td>1 PLACE</td> <td>± 0.5</td> <td>± .020</td> </tr> <tr> <td>0 PLACE</td> <td>±</td> <td>±</td> </tr> </tbody> </table>		mm	INCH	4 PLACES	± .10	± .004	3 PLACES	± .15	± .006	2 PLACES	± 0.30	± .012	1 PLACE	± 0.5	± .020	0 PLACE	±	±	DIMENSION STYLE MM ONLY	SCALE 4:1	DESIGN UNITS METRIC	THIRD ANGLE PROJECTION
		mm	INCH																					
	4 PLACES	± .10	± .004																					
	3 PLACES	± .15	± .006																					
2 PLACES	± 0.30	± .012																						
1 PLACE	± 0.5	± .020																						
0 PLACE	±	±																						
DRAWN BY: JMWESLEY DATE: 06-16-02 CHECKED BY: DGRIFITHS DATE: 07-09-02 APPROVED BY: WKOSHY DATE: 2010/12/08	MATERIAL NO. SEE BOM	DOCUMENT NO. SD-33486-161	SHEET NO. 4 OF 9																					
DRAFT WHERE APPLICABLE MUST REMAIN WITHIN DIMENSIONS		THIS DRAWING CONTAINS INFORMATION THAT IS PROPRIETARY TO MOLEX INCORPORATED AND SHOULD NOT BE USED WITHOUT WRITTEN PERMISSION																						

ASSEMBLY DESCRIPTION	ASSEMBLY PART NUMBER	A	B	C	D	E	F	G	H	A	C	D	GCS	SB1	SB2	SB3	SB4	SB5	SB6	SB7	SB8	SB9	SB10	SB11	SB12	SB13	SB14	SB15	STATUS	COMMENTS
KEY A, BLACK	33486-1845	A											GCS																	
KEY A, BLACK	33486-1844	A											GCS																	
KEY A, BLACK	33486-1843	A											GCS																	
KEY A, BLACK	33486-1842	A											GCS																	
KEY A, BLACK	33486-1841	A											GCS																	
KEY H, W/ S.B., YELLOW	33486-1840	A											GCS																	
KEY E, BLACK	33486-1839	A											GCS																	
KEY E, BLACK	33486-1838	A											GCS																	
KEY A, BLACK	33486-1837	A											GCS																	
KEY B, LIGHT GRAY	33486-1836	B											GCS																	
KEY B, LIGHT GRAY	33486-1835	B											GCS																	
KEY B, LIGHT GRAY	33486-1832	B											GCS																	
KEY A, BLACK	33486-1833	A											GCS																	
KEY A, BLACK	33486-1832	A											GCS																	
KEY E, W/ S.B., BLACK	33486-1831	A											GCS	SB1																
KEY A, BLACK	33486-1830	A											GCS																	
KEY A, BLACK	33486-1829	A											GCS																	
KEY A, BLACK	33486-1828	A											GCS																	
KEY A, BLACK	33486-1827	A											GCS																	
KEY A, BLACK	33486-1826	A											GCS																	
KEY A, BLACK	33486-1825	A											GCS																	
KEY E, W/ S.B., BLACK	33486-1824	A											GCS	SB3																
KEY A, BLACK	33486-1823	A											GCS																	
KEY A, BLACK	33486-1822	A											GCS																	
KEY A, BLACK	33486-1821	A											GCS																	
KEY A, BLACK	33486-1820	A											GCS																	
KEY A, BLACK	33486-1819	A											GCS																	
KEY A, BLACK	33486-1818	A											GCS																	
KEY A, BLACK	33486-1817	A											GCS																	
KEY A, BLACK	33486-1816	A											GCS																	
KEY A, BLACK	33486-1815	A											GCS																	
KEY A, BLACK	33486-1814	A											GCS																	
KEY A, BLACK	33486-1813	A											GCS																	
KEY A, BLACK	33486-1812	A											GCS																	
KEY B, LIGHT GRAY	33486-1811	B											GCS																	
KEY B, LIGHT GRAY	33486-1810	B											GCS																	
KEY B, LIGHT GRAY	33486-1809	B											GCS																	
KEY A, YELLOW	33486-1808	A											GCS																	
KEY A, BLACK	33486-1807	A											GCS																	
KEY A, BLACK	33486-1806	A											GCS																	
KEY A, BLACK	33486-1805	A											GCS																	
KEY A, BLACK	33486-1804	A											GCS																	
KEY A, BLACK	33486-1803	A											GCS																	
KEY A, BLACK	33486-1802	A											GCS																	
KEY A, BLACK	33486-1801	A											GCS																	
KEY A, BLACK	33486-1799	A											GCS																	
KEY A, BLACK	33486-1798	A											GCS																	
KEY A, BLACK	33486-1797	A											GCS																	
KEY A, BLACK	33486-1796	A											GCS																	
KEY A, BLACK	33486-1795	A											GCS																	
KEY A, BLACK	33486-1794	A											GCS																	
KEY A, BLACK	33486-1793	A											GCS																	
KEY A, BLACK	33486-1792	A											GCS																	
KEY A, BLACK	33486-1791	A											GCS																	
KEY A, BLACK	33486-1790	A											GCS																	
KEY A, BLACK	33486-1789	A											GCS																	
KEY A, BLACK	33486-1788	A											GCS																	
KEY A, BLACK	33486-1787	A											GCS																	
KEY A, BLACK	33486-1786	A											GCS																	
KEY A, BLACK	33486-1785	A											GCS																	
KEY A, BLACK	33486-1784	A											GCS																	
KEY A, BLACK	33486-1783	A											GCS																	
KEY E, W/ S.B., BLACK	33486-1782	A											GCS	SB4																
KEY A, BLACK	33486-1781	A											GCS																	
KEY A, BLACK	33486-1780	A											GCS																	
KEY A, BLACK	33486-1779	A											GCS																	
KEY A, BLACK	33486-1778	A											GCS																	
KEY A, BLACK	33486-1777	A											GCS																	
KEY A, BLACK	33486-1776	A											GCS																	
KEY H, W/ S.B., YELLOW	33486-1775	A											GCS	SB2																
KEY H, W/ S.B., YELLOW	33486-1774	A											GCS	SB2																
KEY H, W/ S.B., YELLOW	33486-1773	A											GCS	SB2																
KEY H, W/ S.B., YELLOW	33486-1772	A											GCS	SB2																
KEY A, BLACK	33486-1771	A											GCS																	
KEY A, BLACK	33486-1770	A											GCS																	
KEY A, BLACK	33486-1769	A											GCS																	
KEY A, BLACK	33486-1768	A											GCS																	
KEY H, W/ S.B., YELLOW	33486-1767	A											GCS	SB1																
KEY H, W/ S.B., YELLOW	33486-1766	A											GCS	SB1																
KEY F, W/ S.B., LIGHT GRAY	33486-1765	A											GCS	SB1	SB2	SB3	SB4	SB5	SB6	SB7	SB8	SB9	SB10	SB11	SB12	SB13	SB14	SB15		

PLANNED OBSOLESC

KEY	DESCRIPTION	ASSEMBLY PART NUMBER	QTY	STATUS	COMMENTS
KEY H, YELLOW	33486-2103	A			
KEY A, BLACK	33486-2102	A			
KEY A, BLACK	33486-2101	A			
KEY B, LIGHT GRAY	33486-2100	B			
KEY A, YELLOW	33486-2099	A			
KEY A, YELLOW	33486-2098	A			
KEY A, BLACK	33486-2097	A			
KEY A, BLACK	33486-2096	A			
KEY A, BLACK	33486-2095	A			
KEY A, BLACK	33486-2094	A			
KEY A, BLACK	33486-2093	A			
KEY B, LIGHT GRAY	33486-2092	B			
KEY B, LIGHT GRAY	33486-2091	B			
KEY A, BLACK	33486-2090	A			
KEY A, BLACK	33486-2089	A			
KEY A, BLACK	33486-2088	A			
KEY B, LIGHT GRAY	33486-2087	B			
KEY A, BLACK	33486-2086	A			
KEY A, BLACK	33486-2085	A			
KEY A, BLACK	33486-2084	A			
KEY A, BLACK	33486-2083	A			
KEY A, BLACK	33486-2082	A			
KEY A, BLACK	33486-2081	A			
KEY B, LIGHT GRAY	33486-2080	B			
KEY B, LIGHT GRAY	33486-2079	B			
KEY A, BLACK	33486-2078	A			
KEY A, BLACK	33486-2077	A			
KEY A, BLACK	33486-2076	A			
KEY A, BLACK	33486-2075	A			
KEY F, W/ SB, LIGHT GRAY	33486-2074	F			
KEY F, W/ SB, LIGHT GRAY	33486-2073	F			
KEY A, BLACK	33486-2072	A			
KEY A, BLACK	33486-2071	A			
KEY A, BLACK	33486-2070	A			
KEY A, BLACK	33486-2069	A			
KEY A, BLACK	33486-2068	A			
KEY A, BLACK	33486-2067	A			
KEY F, W/ SB, LIGHT GRAY	33486-2066	F			
KEY F, LIGHT GRAY	33486-2065	F			
KEY A, BLACK	33486-2064	A			
KEY F, W/ SB, LIGHT GRAY	33486-2063	F			
KEY F, W/ SB, LIGHT GRAY	33486-2062	F			
KEY A, BLACK	33486-2061	A			
KEY A, BLACK	33486-2060	A			
KEY B, LIGHT GRAY	33486-2059	B			
KEY B, LIGHT GRAY	33486-2058	B			
KEY A, BLACK	33486-2057	A			
KEY A, BLACK	33486-2056	A			
KEY A, BLACK	33486-2055	A			
KEY A, BLACK	33486-2054	A			
KEY A, BLACK	33486-2053	A			
KEY A, BLACK	33486-2052	A			
KEY A, BLACK	33486-2051	A			
KEY A, BLACK	33486-2050	A			
KEY A, BLACK	33486-2049	A			
KEY A, BLACK	33486-2048	A			
KEY A, BLACK	33486-2047	A			
KEY F, W/ SB, LIGHT GRAY	33486-2046	F			
KEY F, LIGHT GRAY	33486-2045	F			
KEY A, BLACK	33486-2044	A			
KEY A, BLACK	33486-2043	A			
KEY A, BLACK	33486-2042	A			
KEY A, BLACK	33486-2041	A			
KEY A, BLACK	33486-2040	A			
KEY A, BLACK	33486-2039	A			
KEY A, BLACK	33486-2037	A			
KEY A, BLACK	33486-2036	A			
KEY A, BLACK	33486-2035	A			
KEY A, BLACK	33486-2034	A			
KEY A, BLACK	33486-2033	A			
KEY B, LIGHT GRAY	33486-2032	B			
KEY B, LIGHT GRAY	33486-2031	B			
KEY B, LIGHT GRAY	33486-2030	B			
KEY A, BLACK	33486-2029	A			
KEY A, BLACK	33486-2028	A			
KEY A, BLACK	33486-2027	A			
KEY A, BLACK	33486-2026	A			
KEY A, BLACK	33486-2025	A			
KEY A, BLACK	33486-2024	A			
KEY A, BLACK	33486-2023	A			
KEY A, BLACK	33486-2022	A			
KEY A, BLACK	33486-2021	A			
KEY A, BLACK	33486-2020	A			
KEY A, BLACK	33486-2019	A			
KEY A, BLACK	33486-2018	A			
KEY B, LIGHT GRAY	33486-2017	B			
KEY B, LIGHT GRAY	33486-2016	B			
KEY B, LIGHT GRAY	33486-2015	B			
KEY A, BLACK	33486-2014	A			
KEY B, LIGHT GRAY	33486-2013	B			
KEY A, BLACK	33486-2012	A			
KEY A, BLACK	33486-2011	A			
KEY H, YELLOW	33486-2010	H			

PLANNED OBSOLESCENCE
SEE DRAWING SD-34986-8001
FOR REPLACEMENT P/N

NEW SERIES NUMBER IS 34986
SAME SUFFIX

CAVITY WITH AN "X" INDICATES BLOCKED TERMINAL POSITION
CAVITY WITHOUT AN "X" INDICATES OPEN TERMINAL POSITION
CAVITY WITH AN "SB" INDICATES SHORTING BAR CAVITY

PLR	NATURAL	SPS/NYLON GF20
MAT SEAL	ROYAL BLUE	INHERENTLY LUBRICATED SILICONE
SHORTING BAR	GOLD PL	30100 STAINLESS STEEL
SHORTING BAR GROMMET CAP 5	BLACK	SPS/NYLON GF20
SHORTING BAR GROMMET CAP 1	BLACK	SPS/NYLON GF20
SHORTING BAR GROMMET CAP 3	BLACK	SPS/NYLON GF20
SHORTING BAR GROMMET CAP 2	BLACK	SPS/NYLON GF20
SHORTING BAR GROMMET CAP 1	BLACK	SPS/NYLON GF20
STANDARD GROMMET CAP	BLACK	SPS/NYLON GF20
HOUSING KEYING OPTION D	ST GRAY	SPS/NYLON GF20
HOUSING KEYING OPTION C	DARK GRAY	SPS/NYLON GF20
HOUSING KEYING OPTION A	YELLOW	SPS/NYLON GF20
HOUSING KEYING OPTION H	YELLOW	SPS/NYLON GF20
HOUSING KEYING OPTION G	BROWN	SPS/NYLON GF20
HOUSING KEYING OPTION F	LIGHT GRAY	SPS/NYLON GF20
HOUSING KEYING OPTION E	BLACK	SPS/NYLON GF20
HOUSING KEYING OPTION D	GREEN	SPS/NYLON GF20
HOUSING KEYING OPTION C	BROWN	SPS/NYLON GF20
HOUSING KEYING OPTION B	LIGHT GRAY	SPS/NYLON GF20
HOUSING KEYING OPTION A	BLACK	SPS/NYLON GF20

ABBREVIATION	COMPONENT
A	HOUSING KEY A
B	HOUSING KEY B
C	HOUSING KEY C
D	HOUSING KEY D
E	HOUSING KEY E
F	HOUSING KEY F
G	HOUSING KEY G
H	HOUSING KEY H
GCS	STANDARD GROMMET CAP
SB	SHORTING BAR

ENTER DESCRIPTION EC NO: 040205-607 DRAWN BY: JMW CHECKED BY: JMW DATE: 2015/04/27 APPR: WOSHY DATE: 2015/04/28	QUALITY SYMBOLS 0.05 0.1 0.2	GENERAL TOLERANCES (UNLESS SPECIFIED) mm INCH 4 PLACES ± 0.15 ± 0.006 3 PLACES ± 0.10 ± 0.004 2 PLACES ± 0.10 ± 0.004 1 PLACE ± 0.3 ± 0.012 0 PLACE ± ±	DIMENSION STYLE MM ONLY DRAWN BY: JMW DATE: 06-16-02 CHECKED BY: JMW DATE: 07-09-02 APPROVED BY: WOSHY DATE: 2010/12/08	SCALE 2:1 DESIGN UNITS METRIC THIRD ANGLE PROJECTION	MATERIAL NO. SD-33486-161 DOCUMENT NO. SD-33486-161 SHEET NO. 9 OF 9
	DRAFT WHERE APPLICABLE MUST REMAIN WITHIN DIMENSIONS SEE BOM THIS DRAWING CONTAINS INFORMATION THAT IS PROPRIETARY TO MOLEX INCORPORATED AND SHOULD NOT BE USED WITHOUT WRITTEN PERMISSION				
	MOLEX				
	BOM/APPLICABLE COMPONENTS TABLE				