

- 1
- 2
- 3
- 4
- 5
- 6
- 7
- 8
- 9
- 10
- 11
- 12
- 13
- 14
- 15
- 16
- 17
- 18

MATERIAL

Glass-fibre reinforced polyamide based (PA) technopolymer, grey-black colour, matte finish.

SCREW-COVERS

- ECA.P: polyester based technopolymer (PBT) in Elecolors colours, glossy finish, press-fit assembly. Supplied.
Available also as accessories sold separately (see table).

STANDARD EXECUTIONS

- **EWP-EH**: pass-through holes for cylindrical-head screws with hexagonal socket, hexagonal-head screws or standard lock nuts.
- **EWP-SH**: pass-through holes for countersunk head screws.

FEATURES AND APPLICATIONS

EWP handles have been especially designed to fit machine guards or automation systems with single-leaf door. The coloured caps improve the visibility of the handle and offer the possibility of product customisation.

TECHNICAL DATA

Tensile stress: F1 value reported in the table is the result of breaking tests carried out with an appropriate dynamometric equipment under the test conditions shown in the figure with ambient temperature.
Maximum tightening torque for screw assembly 3 Nm.

ACCESSORIES ON REQUEST

- ECA.P: screw-covers in polyester based technopolymer (PBT) in Elecolors colours, glossy finish, press-fit assembly (see table).



RAL7021	RAL2004	RAL7035	RAL1021	RAL5024	RAL3000	RAL6017

ECA.P

Code	Description	Screw-covers for
29865-*	ECA.P5-*	EWP.110

* Complete with colour index (C1, ..., C17).

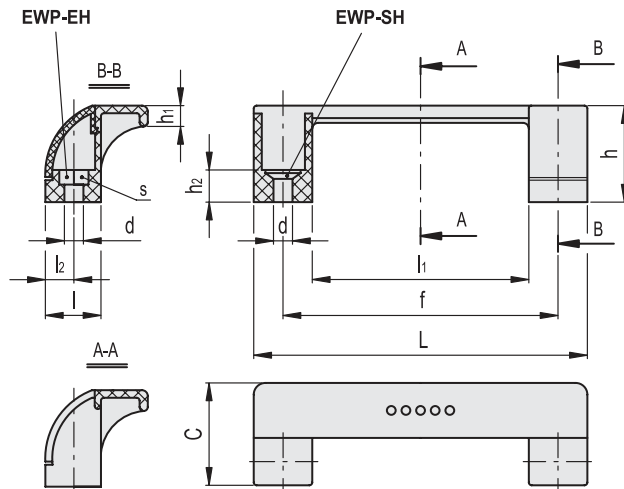
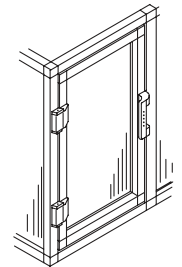

Conversion Table 1 mm = 0.039 inch

L		d		s	
mm	inch	mm	inch	mm	inch
114	4.49	6.5	0.26	10	0.39



* Complete with colour index, example: 265211-C2 EWP.110-EH-C2

RAL7021	RAL2004	RAL7035	RAL1021	RAL5024	RAL3000	RAL6017

Code	Description	L	f±0.5	d	s	h	h1	h2	C	l	l1	l2	F1 [N]	
265211-*	EWP.110-EH-*	114	93.5	6.5	10	33	7	11	35	19	74	9.5	900	26
265251-*	EWP.110-SH-*	114	93.5	6.5	-	33	7	11	35	19	74	9.5	900	26