

HC-DD24-FP-F - Front plate



1201528

<https://www.phoenixcontact.com/us/products/1201528>

Please be informed that the data shown in this PDF document is generated from our online catalog. Please find the complete data in the user documentation. Our general terms of use for downloads are valid.

Guide element/front plate for the easy and secure connection of HC-DD series high-position connectors. Snap onto the contact insert. During connection, the pin contact is guided into place first, preventing contact with the socket contact.



Your advantages

- The funnel plate is used for centering the pin contacts when inserting into the female connector and simplifies handling of the connector

Commercial data

Item number	1201528
Packing unit	1 pc
Minimum order quantity	10 pc
Sales key	BF66
Product key	BF7AZD
GTIN	4063151265908
Weight per piece (including packing)	0.88 g
Weight per piece (excluding packing)	0.88 g
Customs tariff number	39269097
Country of origin	CN

HC-DD24-FP-F - Front plate



1201528

<https://www.phoenixcontact.com/us/products/1201528>

Technical data

Notes

General	Prevents incorrect and angled insertion to a large extent with HC-DD connections
---------	--

Material specifications

Contact carrier material	PC
--------------------------	----

Environmental and real-life conditions

Ambient conditions

Ambient temperature (operation)	-40 °C ... 125 °C (including heating up of contacts)
---------------------------------	--

Mounting

Mounting type	Snap in
Assembly instructions	The plate is snapped into the contact insert by pressing it on. It can be removed again using a screwdriver blade for later unlocking of crimp contacts that were already inserted. Depending on aging and environmental influences, removing the plate may require different levels of force. Plates unlatched inadvertently can be snapped back into place.

HC-DD24-FP-F - Front plate

1201528

<https://www.phoenixcontact.com/us/products/1201528>



Drawings

Schematic diagram

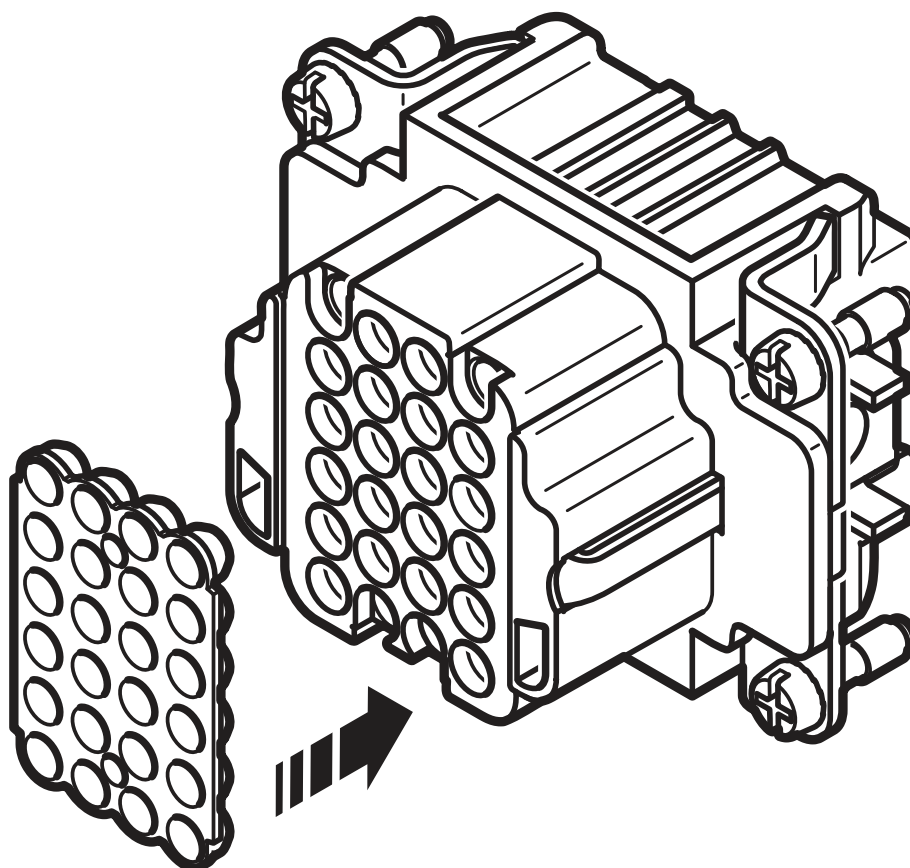

HC-DD24-FP-F - Front plate

1201528

<https://www.phoenixcontact.com/us/products/1201528>



Approvals

To download certificates, visit the product detail page: <https://www.phoenixcontact.com/us/products/1201528>



EAC

Approval ID: RU C-DE.BL08.B.00511

HC-DD24-FP-F - Front plate

1201528

<https://www.phoenixcontact.com/us/products/1201528>



Classifications

ECLASS

ECLASS-11.0	27182806
ECLASS-13.0	27182806
ECLASS-12.0	27182806

ETIM

ETIM 8.0	EC000456
----------	----------

UNSPSC

UNSPSC 21.0	39121300
-------------	----------

HC-DD24-FP-F - Front plate

1201528

<https://www.phoenixcontact.com/us/products/1201528>



Environmental product compliance

China RoHS	Environmentally friendly use period: unlimited = EFUP-e
	No hazardous substances above threshold values

Phoenix Contact 2023 © - all rights reserved
<https://www.phoenixcontact.com>

Phoenix Contact USA
586 Fulling Mill Road
Middletown, PA 17057, United States
(+717) 944-1300
info@phoenixcon.com