

# UM10933

NXP USB Type-C demo kit

Rev. 1 — 11 September 2015

User manual

## Document information

Info	Content
<b>Keywords</b>	USB Type-C, PD (power delivery), Alt-mode-DP, Host, Dock
<b>Abstract</b>	This user manual presents demonstration / application kit capability of power, data, video delivery through single USB Type-C cable between a host board and a dock board, also the power swap, different power profile request capability between these two boards.



**Revision history**

Rev	Date	Description
1	20150916	Initial version.

**Contact information**

For more information, please visit: <http://www.nxp.com>

## 1. Introduction

This demo kit contains two similar boards, which use the same connectors except one. The first board is called host board with USB3 type-B connector, the second one is called dock board with USB3 type-A connector.

This demo kit is intended to demonstrate the power, USB data, and display port video delivery through a single USB Type-C cable between a host board and a dock board, as well as the power swap and high/low power request capability between the host and the dock boards.

This document describes the user manual of NXP USB Type-C demo kit, which includes:

- Overall PCB connectors, jumpers, and power supplies
- Laptop and VGA monitor that this kit will be interfacing with during demo
- System level connections such as cables and connectors needed by this kit

### 1.1 Purpose

For customers to evaluate NXP USB Type-C Power Delivery PHY and protocol IC PTN5100 and DP Alternate Mode features through single USB Type-C connection.

- Power swap between the host and the dock boards
- Power delivery between the host and the dock boards during dead battery condition
- Power delivery selection between 5 V or 20 V
- CC logic and PD control through micro-controller LPC1135
- Transfer power, data, video through USB Type-C cable between the host and the dock boards

## 2. General description

### 2.1 Block diagram

#### 2.1.1 Host board

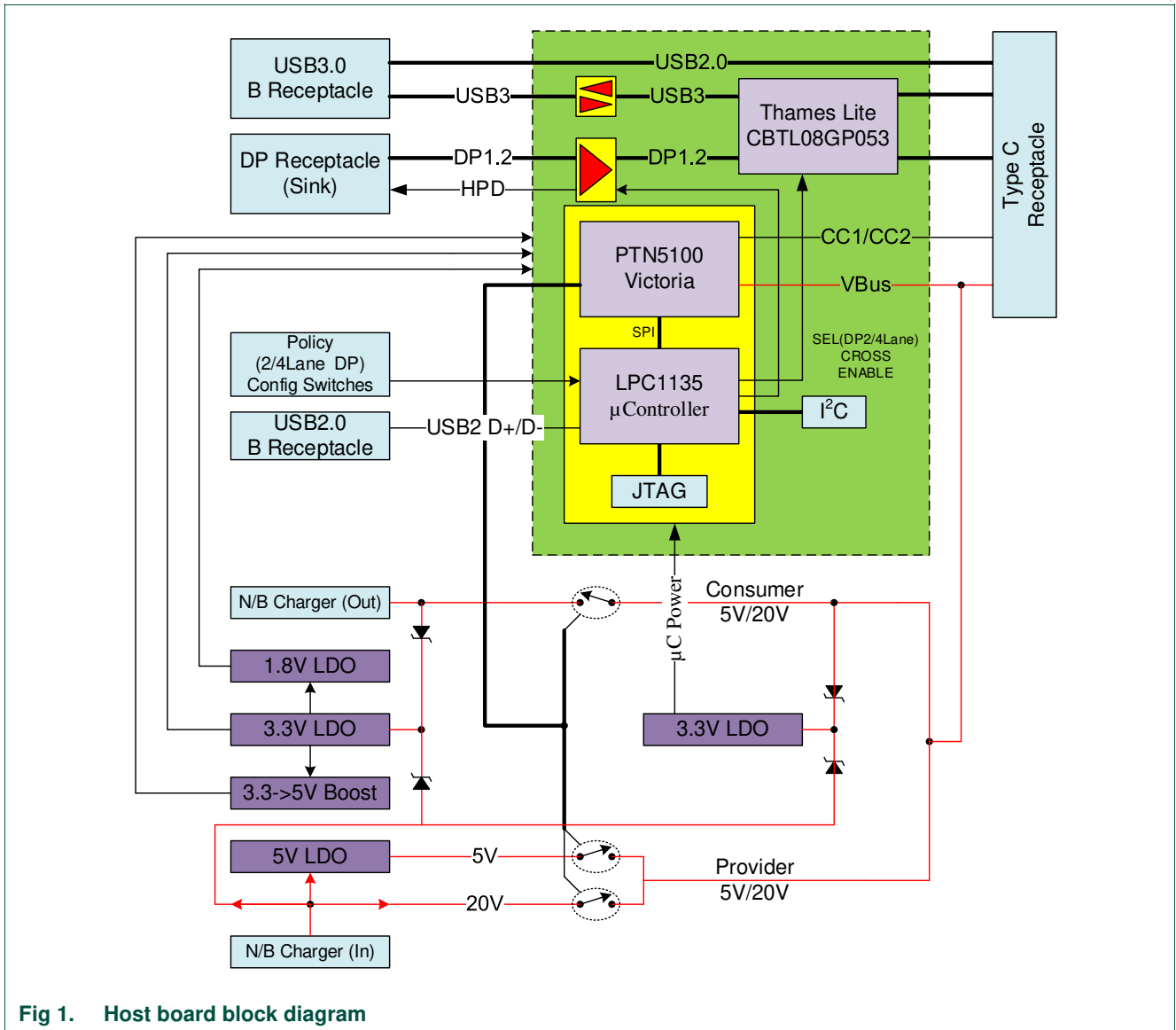

Fig 1. Host board block diagram

2.1.2 Dock board

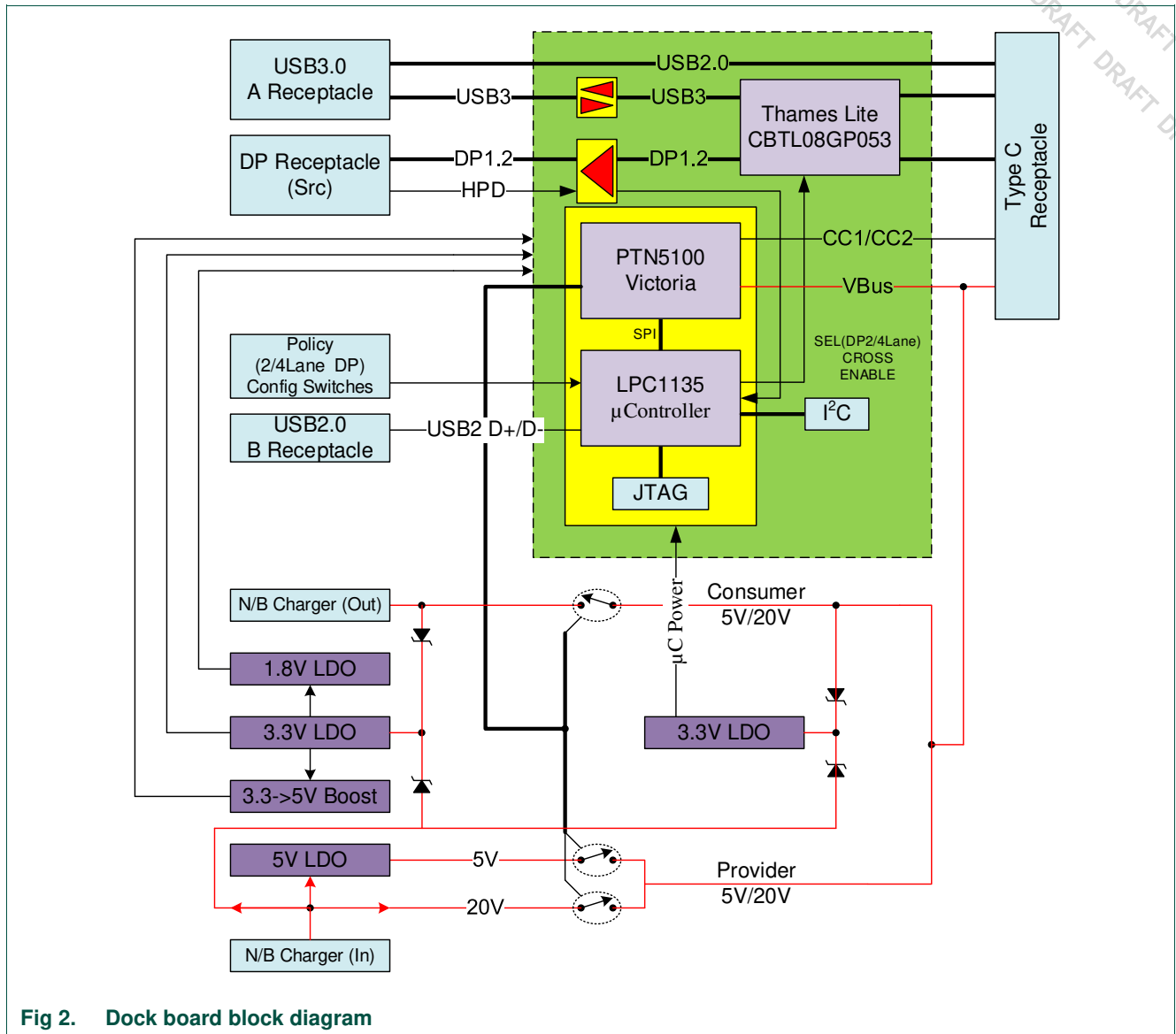

Fig 2. Dock board block diagram

## 2.2 Connectors and jumpers

Please refer to [Fig 3](#) and [Fig 4](#) below to find connectors and jumper's location on the host board and the dock board.

### 2.2.1 Host board connectors and jumpers location

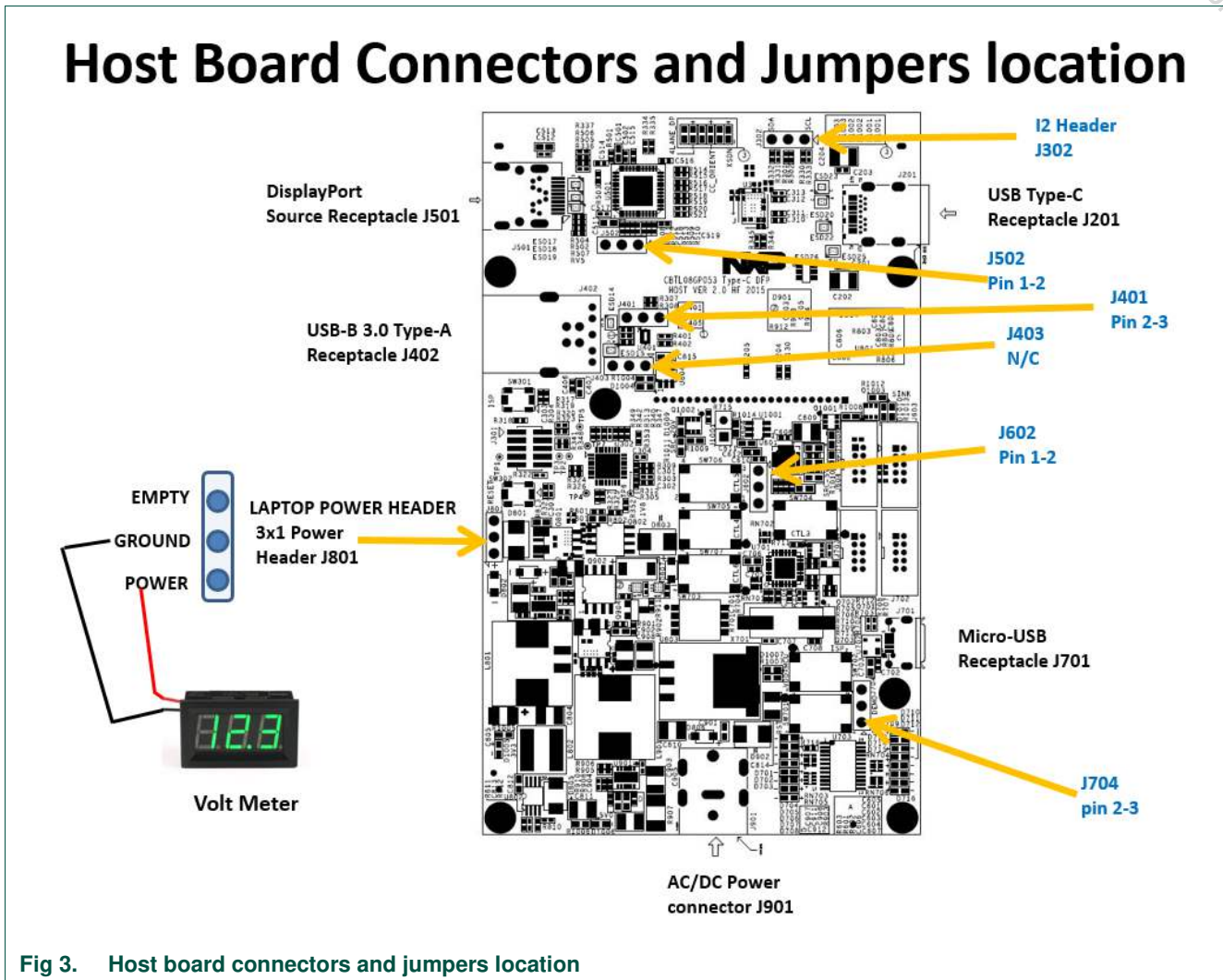

Fig 3. Host board connectors and jumpers location

2.2.2 Dock board connectors and jumpers location

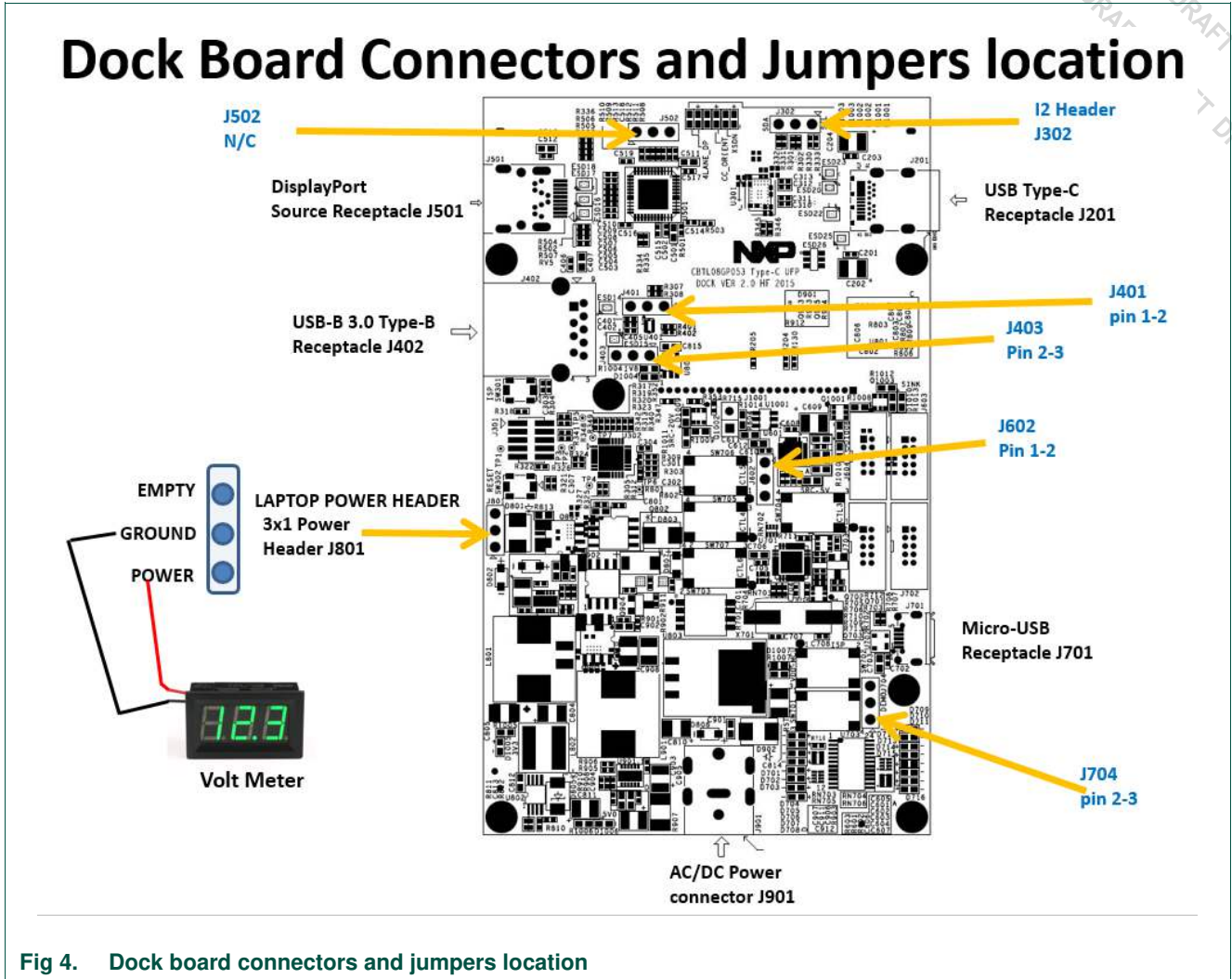

Fig 4. Dock board connectors and jumpers location

2.2.3 Connectors list

Both Host/Dock boards have the following connectors:

- Power connector J901 for AC power adaptor.
- USB3 connector J402, type-A on dock board, type-B on host board.
- Mini-DP receptacle J501.
- USB type-C receptacle J201.
- USB micro-B receptacle J701.
- Voltmeter 3x1 header with 0.1" spacing J801.

## 2.2.4 Jumper setting table

**Table 1. Jumper setting list**

Jumper #	Signal names	Jumper settings	Default setting
J704	VBUS Detect	1-2 VBUS Detect for demo board 2-3 VBUS detect for USB ISP	2-3
J602	CC_CTRL1	1-2 CC_CTRL1 = LOW 2-3 Debug Access	1-2
J401	USB Redriver PTN36241G C1 Setting	1-2 C1 = 1V8 2-3 C1 = GND	1-2 Dock 2-3 Host
J403	USB Redriver PTN36241G C2 Setting	1-2 C2 = 1V8 2-3 C2 = GND	N/C Host 2-3 Dock
J502	I2C_ADDR	1-2 HIGH, I2C Bus Master OPEN, I2C Bus Slave (0xxh) 2-3 LOW, I2C Bus Slave (0xxh)	1-2 Host N/C Dock
J302	I2C Header	1 I2C_SCL 2 GND 3 I2C_SDA	
J801	Power Display Header	1 Power 2 GND 3 Empty	



### 3. Hardware setup

Below is a graphic presentation of the demo hardware setup.

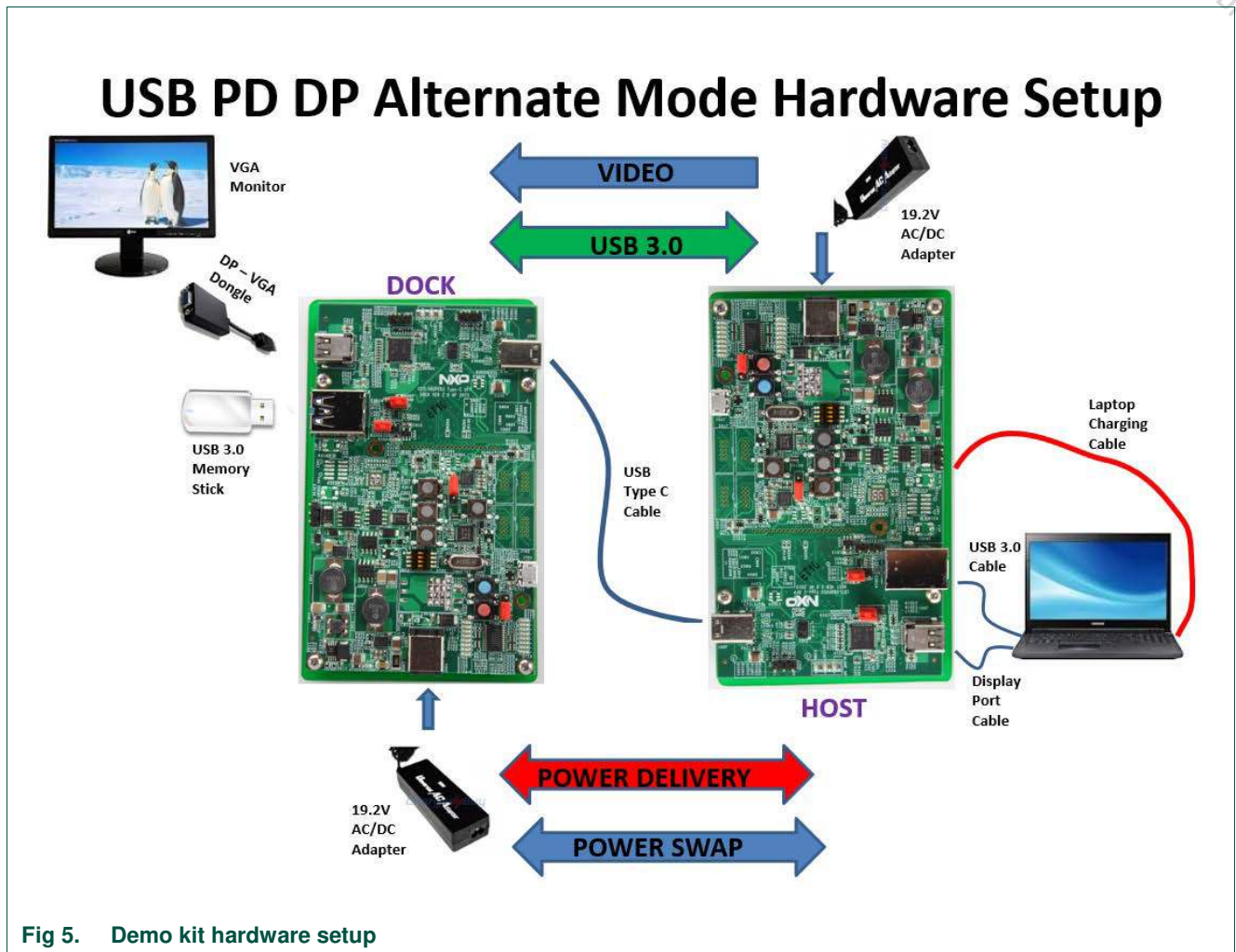

Fig 5. Demo kit hardware setup

3.1 Demo setup picture

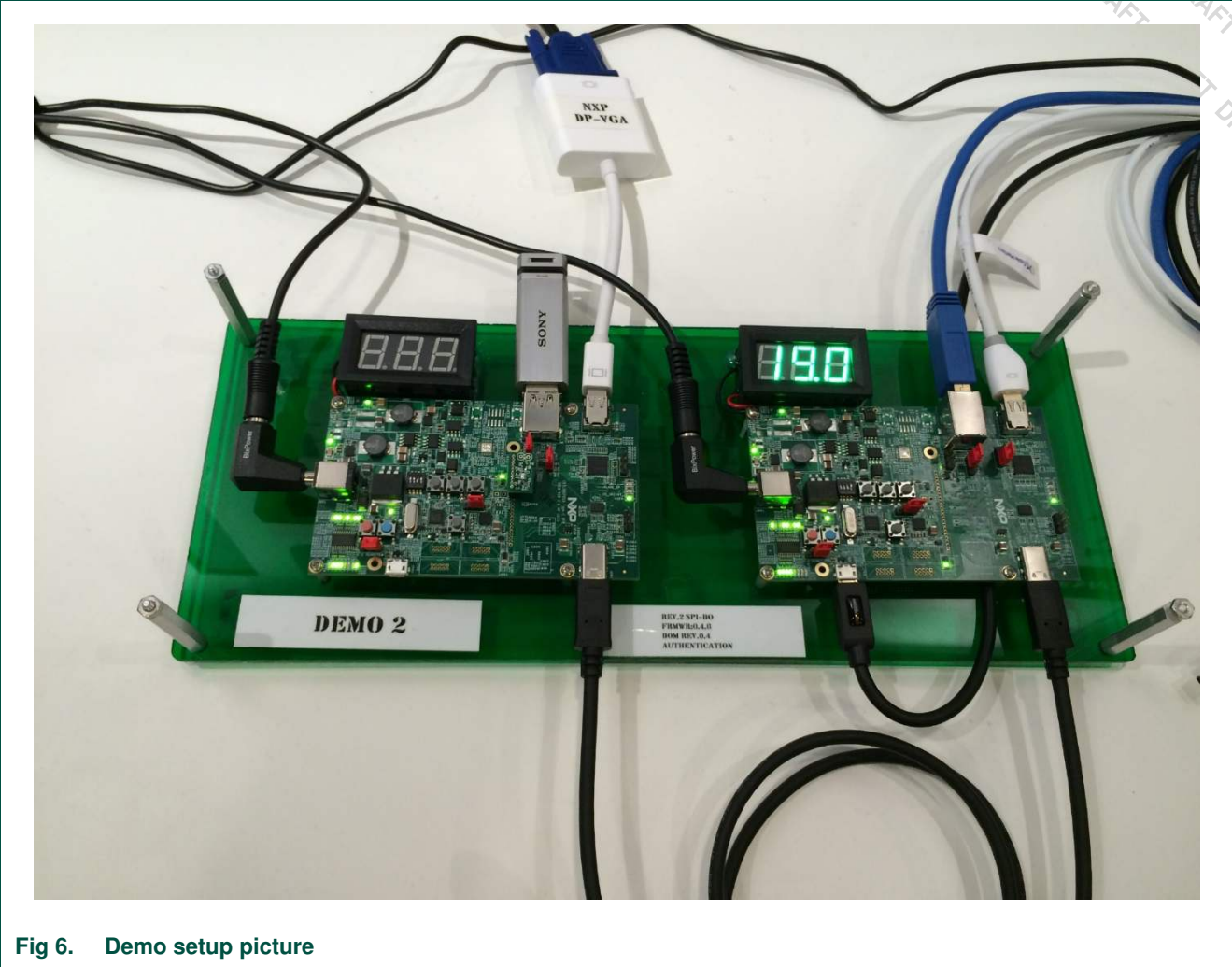

Fig 6. Demo setup picture

### 3.2 Host board control and LED indication

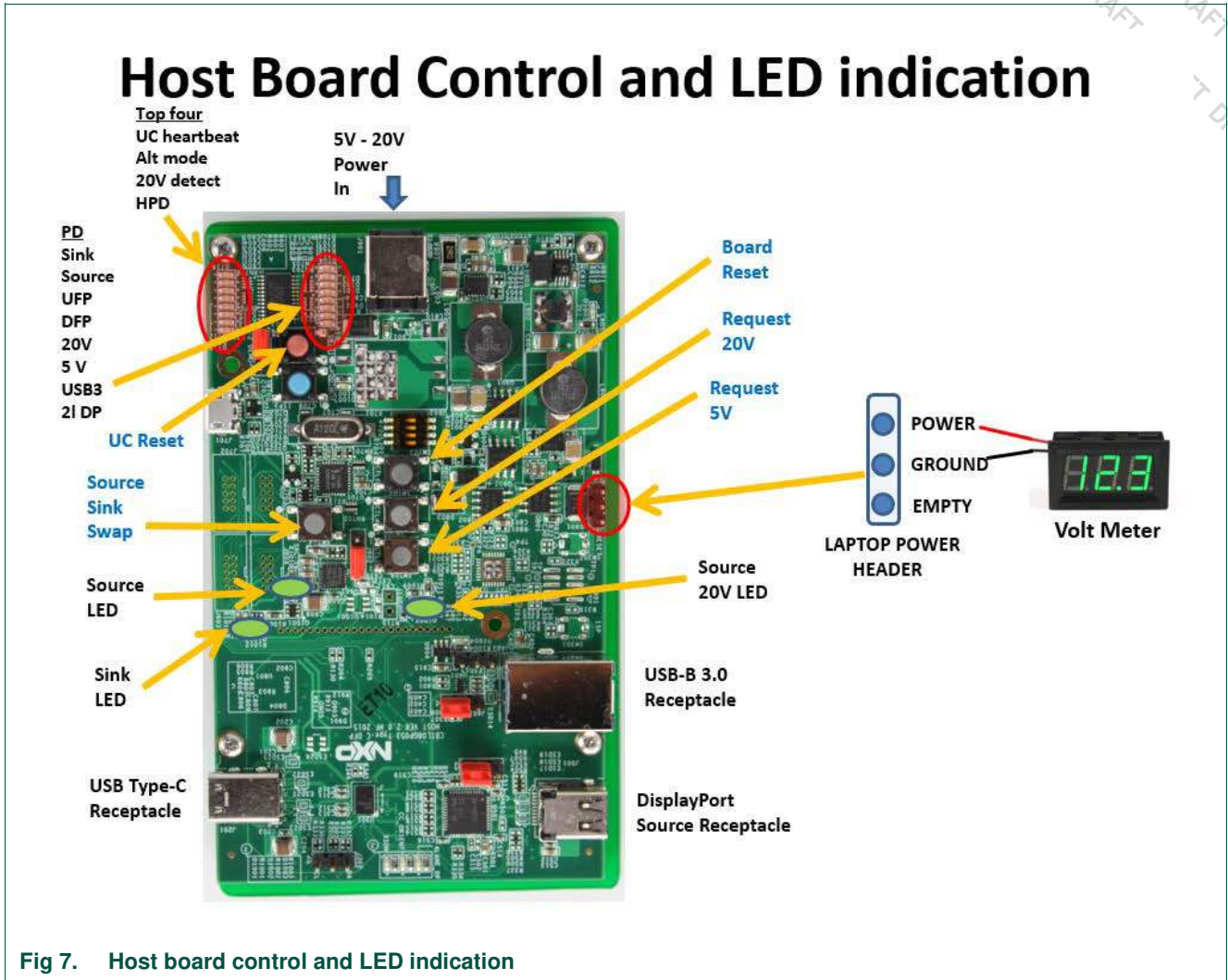

Fig 7. Host board control and LED indication

3.3 Dock board control and LED indication

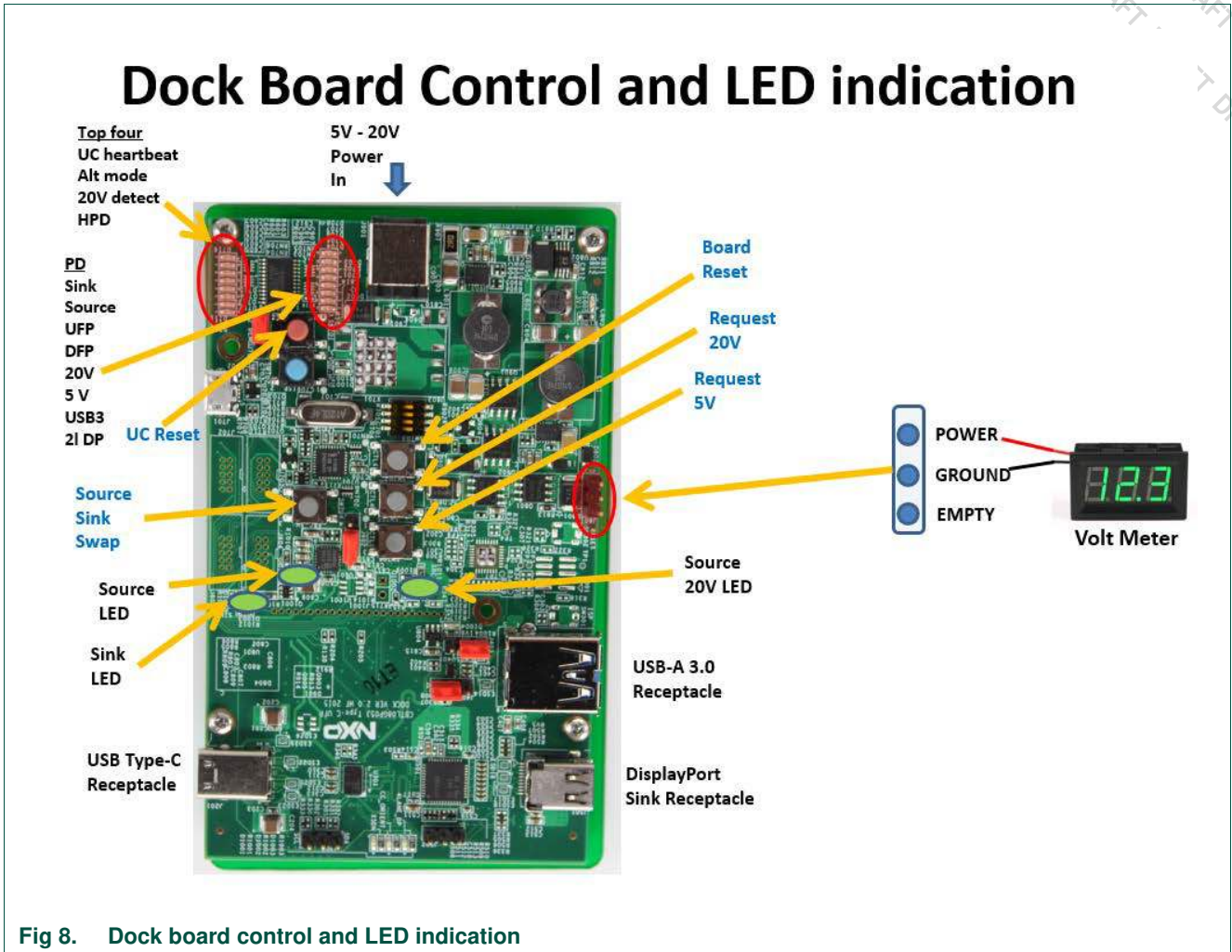

Fig 8. Dock board control and LED indication

### 3.4 Hardware setup procedure

- Connect USB type-C cable between Host and Dock boards on J201
- Connect USB3 cable between Host board J402 and laptop USB3 input port
- Connect Mini-DP cable between Host board J501 and laptop mini-DP input port
- Connect USB micro cable between Host board J701 and laptop USB2 input port.
- Connect mini-DPVGA dongle between Dock board J501 and VGA monitor
- Connect Digital Voltmeter with LCD display to J801 on each board
- Connect AC/DC power adaptor onto Power connector J901 on both boards
- Check 2 LED rows near power connector J901
  - D701-D708
  - D709-D716
  - Unplug and re-plug Type-C cable on both boards to make sure D701-D708 are lighted
- Press red button on SW701 to reset micro-controller if necessary

### 3.5 Power swap demo

Once the power contract is established, check whether the host board is a power source (if source 5 V LED is on) or power sink (if sink LED is on) as shown on [Fig 7](#) and [Fig 8](#).

Use the swap button SW704 to swap the host board to power sink role.

Push request 20 button SW705 on the host board to request 20 V from the dock board, or push request 5 button SW706 to request 5 V from the dock board.

Use the swap button SW704 to swap the host board to power source role.

Push request 20 button SW705 on the dock board to request 20 V from the host board, or push request 5 button SW706 to request 5 V from the host board.

### 3.6 USB PD DP alternate mode video play demo

Check the battery monitoring indicator on the laptop. It should indicate that the laptop is being charged.

Connect USB 3.0 memory stick to Dock board J402.

From the laptop you should be able to access the flash drive on the dock board.

From the laptop you should also be able to play any movie trailer on the flash drive by double click on the icon.

Theory of operation:

Digital video is stored in memory stick which is then read from USB3 port on the Dock board, send to the Host board via USB type-C cable. The data is further transmit to the laptop via USB3 cable. The laptop converts video digital data to streaming video then play it back to the host board through Display Port cable. USB Type-C connection sends the video to the dock board, video is played out to the monitor through DP-VGA converter dongle to the VGA monitor.

## 4. Component list

---

1. NXP USB PD Type-C HOST demo board
2. NXP USB PD Type-C DOCK demo board
3. USB 3.0 Standard A to Standard B cable
4. Mini DisplayPort cable
5. Voltmeter (DROK® Small Little DC Digital Voltmeter 3-30V)  
[http://www.amazon.com/gp/product/B00C2NTJHS?ref\\_=pe\\_823600\\_114105210](http://www.amazon.com/gp/product/B00C2NTJHS?ref_=pe_823600_114105210)
6. Universal Variable 24V ACDC adapter [http://www.amazon.com/Universal-Adapter-15V-18-5V-19-5V/dp/B004I5ERUW/ref=sr\\_1\\_7?ie=UTF8&qid=1434233582&sr=8-7&keywords=universal+laptop+charger](http://www.amazon.com/Universal-Adapter-15V-18-5V-19-5V/dp/B004I5ERUW/ref=sr_1_7?ie=UTF8&qid=1434233582&sr=8-7&keywords=universal+laptop+charger)
7. USB 3.0 flash drive
8. Mini-DP to VGA adapter dongle

**5. Type-C Demo Boards – Errata list**

**Type-C Demo Boards**

**Host Board**



**Dock Board**



PCB Rev	2.0
FW Rev	0.4.4
PTN5100	Rev B0
CBTL08GP053	Rev A0
LPC11U35	MP Version
NX20P5090	Rev A0

On the back side of each demo board, it has serial number for tracking.

Fig 9. Type-C demo boards

## 5.1 Errata list

**Table 2. Errata list**

	Errata list	Host power role	Dock power role	Demo system impact	Solution
1	VCONN (Type-C Receptacle) Max Power = 150mA @5V	VCONN Src	VCONN Src	VCONN cannot provide more than 150mA through USB Type-C	Short term solution: Only demo 150mA current from VCONN Long Term Fix: New PCB design with larger LDO
2	VBUS High to Low voltage (5V) transitions is outside the PD spec	Provider	Dead battery	System may not pass compliance when VBUS has high to low voltage (5V) transition	Short term solution: Not Available Long Term Fix: New PCB Design



## 6. Legal information

### 6.1 Definitions

**Draft** — The document is a draft version only. The content is still under internal review and subject to formal approval, which may result in modifications or additions. NXP Semiconductors does not give any representations or warranties as to the accuracy or completeness of information included herein and shall have no liability for the consequences of use of such information.

### 6.2 Disclaimers

**Limited warranty and liability** — Information in this document is believed to be accurate and reliable. However, NXP Semiconductors does not give any representations or warranties, expressed or implied, as to the accuracy or completeness of such information and shall have no liability for the consequences of use of such information. NXP Semiconductors takes no responsibility for the content in this document if provided by an information source outside of NXP Semiconductors.

In no event shall NXP Semiconductors be liable for any indirect, incidental, punitive, special or consequential damages (including - without limitation - lost profits, lost savings, business interruption, costs related to the removal or replacement of any products or rework charges) whether or not such damages are based on tort (including negligence), warranty, breach of contract or any other legal theory.

Notwithstanding any damages that customer might incur for any reason whatsoever, NXP Semiconductors' aggregate and cumulative liability towards customer for the products described herein shall be limited in accordance with the *Terms and conditions of commercial sale* of NXP Semiconductors.

**Right to make changes** — NXP Semiconductors reserves the right to make changes to information published in this document, including without limitation specifications and product descriptions, at any time and without notice. This document supersedes and replaces all information supplied prior to the publication hereof.

**Suitability for use** — NXP Semiconductors products are not designed, authorized or warranted to be suitable for use in life support, life-critical or safety-critical systems or equipment, nor in applications where failure or malfunction of an NXP Semiconductors product can reasonably be expected to result in personal injury, death or severe property or environmental damage. NXP Semiconductors and its suppliers accept no liability for inclusion and/or use of NXP Semiconductors products in such equipment or applications and therefore such inclusion and/or use is at the customer's own risk.

**Applications** — Applications that are described herein for any of these products are for illustrative purposes only. NXP Semiconductors makes no representation or warranty that such applications will be suitable for the specified use without further testing or modification.

Customers are responsible for the design and operation of their applications and products using NXP Semiconductors products, and NXP Semiconductors accepts no liability for any assistance with applications or

customer product design. It is customer's sole responsibility to determine whether the NXP Semiconductors product is suitable and fit for the customer's applications and products planned, as well as for the planned application and use of customer's third party customer(s). Customers should provide appropriate design and operating safeguards to minimize the risks associated with their applications and products.

NXP Semiconductors does not accept any liability related to any default, damage, costs or problem which is based on any weakness or default in the customer's applications or products, or the application or use by customer's third party customer(s). Customer is responsible for doing all necessary testing for the customer's applications and products using NXP Semiconductors products in order to avoid a default of the applications and the products or of the application or use by customer's third party customer(s). NXP does not accept any liability in this respect.

**Export control** — This document as well as the item(s) described herein may be subject to export control regulations. Export might require a prior authorization from competent authorities.

**Translations** — A non-English (translated) version of a document is for reference only. The English version shall prevail in case of any discrepancy between the translated and English versions.

**Evaluation products** — This product is provided on an "as is" and "with all faults" basis for evaluation purposes only. NXP Semiconductors, its affiliates and their suppliers expressly disclaim all warranties, whether express, implied or statutory, including but not limited to the implied warranties of non-infringement, merchantability and fitness for a particular purpose. The entire risk as to the quality, or arising out of the use or performance, of this product remains with customer.

In no event shall NXP Semiconductors, its affiliates or their suppliers be liable to customer for any special, indirect, consequential, punitive or incidental damages (including without limitation damages for loss of business, business interruption, loss of use, loss of data or information, and the like) arising out of the use of or inability to use the product, whether or not based on tort (including negligence), strict liability, breach of contract, breach of warranty or any other theory, even if advised of the possibility of such damages.

Notwithstanding any damages that customer might incur for any reason whatsoever (including without limitation, all damages referenced above and all direct or general damages), the entire liability of NXP Semiconductors, its affiliates and their suppliers and customer's exclusive remedy for all of the foregoing shall be limited to actual damages incurred by customer based on reasonable reliance up to the greater of the amount actually paid by customer for the product or five dollars (US\$5.00). The foregoing limitations, exclusions and disclaimers shall apply to the maximum extent permitted by applicable law, even if any remedy fails of its essential purpose.

### 6.3 Trademarks

Notice: All referenced brands, product names, service names and trademarks are property of their respective owners.

## 7. List of figures

Fig 1.	Host board block diagram .....	4
Fig 2.	Dock board block diagram .....	5
Fig 3.	Host board connectors and jumpers location ....	6
Fig 4.	Dock board connectors and jumpers location ...	7
Fig 5.	Demo kit hardware setup .....	9
Fig 6.	Demo setup picture .....	10
Fig 7.	Host board control and LED indication.....	11
Fig 8.	Dock board control and LED indication .....	12
Fig 9.	Type-C demo boards .....	15

## 8. List of tables

---

Table 1. Jumper setting list .....	8
Table 2. Errata list .....	16

## 9. Contents

<b>1.</b>	<b>Introduction .....</b>	<b>3</b>
1.1	Purpose.....	3
<b>2.</b>	<b>General description.....</b>	<b>4</b>
2.1	Block diagram .....	4
2.1.1	Host board.....	4
2.1.2	Dock board.....	5
2.2	Connectors and jumpers .....	6
2.2.1	Host board connectors and jumpers location .....	6
2.2.2	Dock board connectors and jumpers location .....	7
2.2.3	Connectors list .....	7
2.2.4	Jumper setting table .....	8
<b>3.</b>	<b>Hardware setup .....</b>	<b>9</b>
3.1	Demo setup picture .....	10
3.2	Host board control and LED indication .....	11
3.3	Dock board control and LED indication .....	12
3.4	Hardware setup procedure.....	13
3.5	Power swap demo.....	13
3.6	USB PD DP alternate mode video play demo..	13
<b>4.</b>	<b>Component list .....</b>	<b>14</b>
<b>5.</b>	<b>Type-C Demo Boards – Errata list .....</b>	<b>15</b>
5.1	Errata list.....	16
<b>6.</b>	<b>Legal information .....</b>	<b>17</b>
6.1	Definitions .....	17
6.2	Disclaimers.....	17
6.3	Trademarks .....	17
<b>7.</b>	<b>List of figures.....</b>	<b>18</b>
<b>8.</b>	<b>List of tables .....</b>	<b>19</b>
<b>9.</b>	<b>Contents.....</b>	<b>20</b>

---

Please be aware that important notices concerning this document and the product(s) described herein, have been included in the section 'Legal information'.

---