



**THIS SPEC IS OBSOLETE**

**Spec No:** 38-05489

**Spec Title:** CY7C1512V18/CY7C1514V18, 72 MBIT  
QDR(R) II SRAM TWO WORD BURST  
ARCHITECTURE

**Sunset Owner:** Jayasree Nayar (NJY)

**Replaced by:** None



# 72-Mbit QDR<sup>®</sup> II SRAM Two-Word Burst Architecture

## Features

- Separate independent read and write data ports
  - Supports concurrent transactions
- 250 MHz clock for high bandwidth
- Two-word burst on all accesses
- Double data rate (DDR) interfaces on both read and write ports (data transferred at 500 MHz) at 250 MHz
- Two input clocks (K and  $\bar{K}$ ) for precise DDR timing
  - SRAM uses rising edges only
- Two input clocks for output data (C and  $\bar{C}$ ) to minimize clock skew and flight time mismatches
- Echo clocks (CQ and  $\bar{CQ}$ ) simplify data capture in high-speed systems
- Single multiplexed address input bus latches address inputs for both read and write ports
- Separate port selects for depth expansion
- Synchronous internally self-timed writes
- Available in x18, and x36 configurations
- Full data coherency, providing most current data
- Core  $V_{DD} = 1.8\text{ V}$  ( $\pm 0.1\text{ V}$ ); I/O  $V_{DDQ} = 1.4\text{ V}$  to  $V_{DD}$
- Available in 165-Ball FBGA package (15 × 17 × 1.4 mm)
- Offered in both Pb-free and non Pb-free packages
- Variable drive high-speed transceiver logic (HSTL) output buffers
- JTAG 1149.1 compatible test access port
- Delay lock loop (DLL) for accurate data placement

## Configurations

CY7C1512V18 – 4 M × 18

CY7C1514V18 – 2 M × 36

## Selection Guide

Description		250 MHz	200 MHz	167 MHz	Unit
Maximum operating frequency		250	200	167	MHz
Maximum operating current	x18	900	800	750	mA
	x36	1100	900	800	

## Functional Description

The CY7C1512V18, and CY7C1514V18 are 1.8 V Synchronous Pipelined SRAMs, equipped with QDR<sup>®</sup> II architecture. QDR II architecture consists of two separate ports: the read port and the write port to access the memory array. The read port has dedicated data outputs to support read operations and the write port has dedicated data inputs to support write operations. QDR II architecture has separate data inputs and data outputs to completely eliminate the need to “turnaround” the data bus that exists with common I/O devices. Access to each port is through a common address bus. Addresses for read and write addresses are latched on alternate rising edges of the input (K) clock. Accesses to the QDR II read and write ports are completely independent of one another. To maximize data throughput, both read and write ports are equipped with DDR interfaces. Each address location is associated with two 18-bit words (CY7C1512V18), or 36-bit words (CY7C1514V18) that burst sequentially into or out of the device. Because data can be transferred into and out of the device on every rising edge of both input clocks (K and  $\bar{K}$  and C and  $\bar{C}$ ), memory bandwidth is maximized while simplifying system design by eliminating bus “turnarounds”.

Depth expansion is accomplished with port selects, which enables each port to operate independently.

All synchronous inputs pass through input registers controlled by the K or  $\bar{K}$  input clocks. All data outputs pass through output registers controlled by the C or  $\bar{C}$  (or K or  $\bar{K}$  in a single clock domain) input clocks. Writes are conducted with on-chip synchronous self-timed write circuitry.

### Logic Block Diagram (CY7C1512V18)

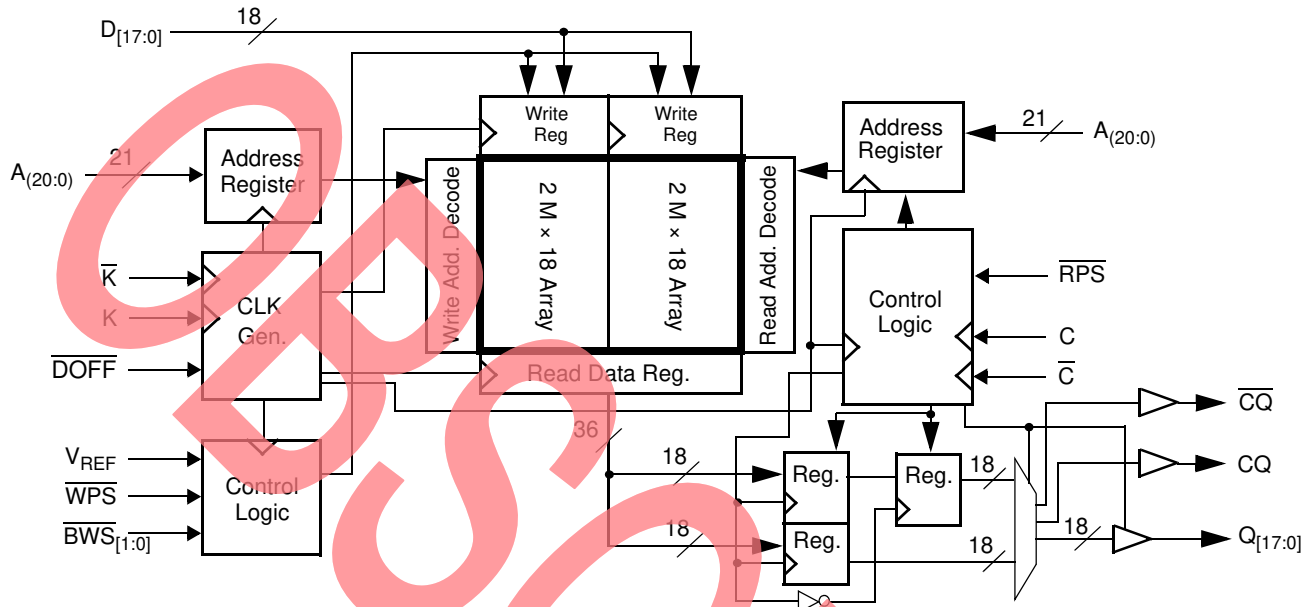

### Logic Block Diagram (CY7C1514V18)

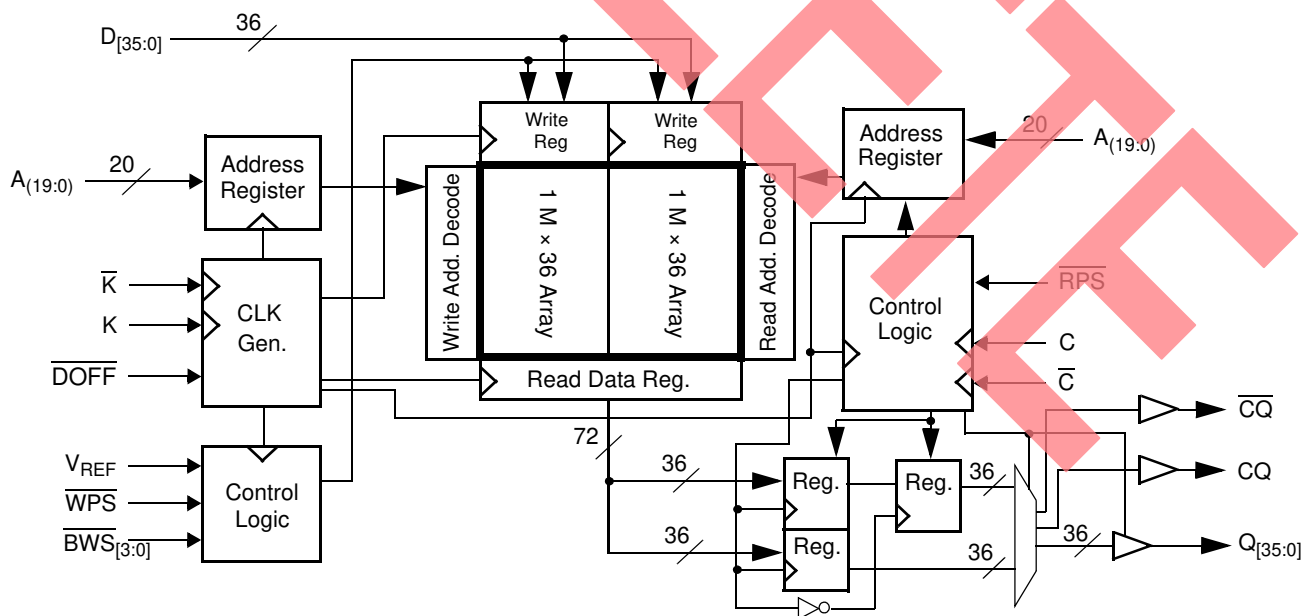

## Contents

<b>72-Mbit QDR® II SRAM Two-Word Burst Architecture</b> ..	1	<b>TAP Electrical Characteristics</b> .....	14
<b>Features</b> .....	1	<b>TAP AC Switching Characteristics</b> .....	15
<b>Configurations</b> .....	1	<b>TAP Timing and Test Conditions</b> .....	15
<b>Functional Description</b> .....	1	<b>Identification Register Definitions</b> .....	16
<b>Selection Guide</b> .....	1	<b>Scan Register Sizes</b> .....	16
<b>Logic Block Diagram (CY7C1512V18)</b> .....	2	<b>Instruction Codes</b> .....	16
<b>Logic Block Diagram (CY7C1514V18)</b> .....	2	<b>Boundary Scan Order</b> .....	17
<b>Pin Configuration</b> .....	4	<b>Power-up Sequence in QDR II SRAM</b> .....	18
165-Ball FBGA (15 × 17 × 1.4 mm) Pinout .....	4	Power-up Sequence .....	18
<b>Pin Definitions</b> .....	5	DLL Constraints .....	18
<b>Functional Overview</b> .....	7	<b>Maximum Ratings</b> .....	19
Read Operations .....	7	<b>Operating Range</b> .....	19
Write Operations .....	7	<b>Neutron Soft Error Immunity</b> .....	19
Byte Write Operations .....	7	<b>Electrical Characteristics</b> .....	19
Single Clock Mode .....	7	DC Electrical Characteristics .....	19
Concurrent Transactions .....	7	AC Electrical Characteristics .....	20
Depth Expansion .....	7	<b>Capacitance</b> .....	21
Programmable Impedance .....	7	<b>Thermal Resistance</b> .....	21
Echo Clocks .....	8	<b>Switching Characteristics</b> .....	22
DLL .....	8	<b>Switching Waveforms</b> .....	23
<b>Application Example</b> .....	8	<b>Ordering Information</b> .....	24
<b>Truth Table</b> .....	9	<b>Package Diagram</b> .....	25
<b>Write Cycle Descriptions</b> .....	9	<b>Acronyms</b> .....	26
<b>Write Cycle Descriptions</b> .....	10	<b>Reference Documents</b> .....	26
<b>IEEE 1149.1 Serial Boundary Scan (JTAG)</b> .....	11	<b>Document Conventions</b> .....	26
Disabling the JTAG Feature .....	11	Units of Measure .....	26
Test Access Port—Test Clock .....	11	Port Nomenclature .....	26
Test Mode Select (TMS) .....	11	Bit Field Nomenclature .....	26
Test Data-In (TDI) .....	11	<b>Glossary</b> .....	26
Test Data-Out (TDO) .....	11	<b>Document History Page</b> .....	27
Performing a TAP Reset .....	11	<b>Sales, Solutions, and Legal Information</b> .....	29
TAP Registers .....	11	Worldwide Sales and Design Support .....	29
TAP Instruction Set .....	12	Products .....	29
<b>TAP Controller State Diagram</b> .....	13	PSoC Solutions .....	29
<b>TAP Controller Block Diagram</b> .....	14		

## Pin Configuration

The pin configuration for CY7C1512V18, and CY7C1514V18 follow. <sup>[1]</sup>

### 165-Ball FBGA (15 × 17 × 1.4 mm) Pinout

**Table 1. CY7C1512V18 (4 M × 18)**

	1	2	3	4	5	6	7	8	9	10	11
<b>A</b>	CQ	V <sub>SS</sub> /144M	A	WPS	BWS <sub>1</sub>	K	NC/288 M	RPS	A	A	CQ
<b>B</b>	NC	Q9	D9	A	NC	K	BWS <sub>0</sub>	A	NC	NC	Q8
<b>C</b>	NC	NC	D10	V <sub>SS</sub>	A	A	A	V <sub>SS</sub>	NC	Q7	D8
<b>D</b>	NC	D11	Q10	V <sub>SS</sub>	V <sub>SS</sub>	V <sub>SS</sub>	V <sub>SS</sub>	V <sub>SS</sub>	NC	NC	D7
<b>E</b>	NC	NC	Q11	V <sub>DDQ</sub>	V <sub>SS</sub>	V <sub>SS</sub>	V <sub>SS</sub>	V <sub>DDQ</sub>	NC	D6	Q6
<b>F</b>	NC	Q12	D12	V <sub>DDQ</sub>	V <sub>DD</sub>	V <sub>SS</sub>	V <sub>DD</sub>	V <sub>DDQ</sub>	NC	NC	Q5
<b>G</b>	NC	D13	Q13	V <sub>DDQ</sub>	V <sub>DD</sub>	V <sub>SS</sub>	V <sub>DD</sub>	V <sub>DDQ</sub>	NC	NC	D5
<b>H</b>	DOFF	V <sub>REF</sub>	V <sub>DDQ</sub>	V <sub>DDQ</sub>	V <sub>DD</sub>	V <sub>SS</sub>	V <sub>DD</sub>	V <sub>DDQ</sub>	V <sub>DDQ</sub>	V <sub>REF</sub>	ZQ
<b>J</b>	NC	NC	D14	V <sub>DDQ</sub>	V <sub>DD</sub>	V <sub>SS</sub>	V <sub>DD</sub>	V <sub>DDQ</sub>	NC	Q4	D4
<b>K</b>	NC	NC	Q14	V <sub>DDQ</sub>	V <sub>DD</sub>	V <sub>SS</sub>	V <sub>DD</sub>	V <sub>DDQ</sub>	NC	D3	Q3
<b>L</b>	NC	Q15	D15	V <sub>DDQ</sub>	V <sub>SS</sub>	V <sub>SS</sub>	V <sub>SS</sub>	V <sub>DDQ</sub>	NC	NC	Q2
<b>M</b>	NC	NC	D16	V <sub>SS</sub>	V <sub>SS</sub>	V <sub>SS</sub>	V <sub>SS</sub>	V <sub>SS</sub>	NC	Q1	D2
<b>N</b>	NC	D17	Q16	V <sub>SS</sub>	A	A	A	V <sub>SS</sub>	NC	NC	D1
<b>P</b>	NC	NC	Q17	A	A	C	A	A	NC	D0	Q0
<b>R</b>	TDO	TCK	A	A	A	C	A	A	A	TMS	TDI

**Table 2. CY7C1514V18 (2 M × 36)**

	1	2	3	4	5	6	7	8	9	10	11
<b>A</b>	CQ	V <sub>SS</sub> /288 M	A	WPS	BWS <sub>2</sub>	K	BWS <sub>1</sub>	RPS	A	V <sub>SS</sub> /144 M	CQ
<b>B</b>	Q27	Q18	D18	A	BWS <sub>3</sub>	K	BWS <sub>0</sub>	A	D17	Q17	Q8
<b>C</b>	D27	Q28	D19	V <sub>SS</sub>	A	A	A	V <sub>SS</sub>	D16	Q7	D8
<b>D</b>	D28	D20	Q19	V <sub>SS</sub>	V <sub>SS</sub>	V <sub>SS</sub>	V <sub>SS</sub>	V <sub>SS</sub>	Q16	D15	D7
<b>E</b>	Q29	D29	Q20	V <sub>DDQ</sub>	V <sub>SS</sub>	V <sub>SS</sub>	V <sub>SS</sub>	V <sub>DDQ</sub>	Q15	D6	Q6
<b>F</b>	Q30	Q21	D21	V <sub>DDQ</sub>	V <sub>DD</sub>	V <sub>SS</sub>	V <sub>DD</sub>	V <sub>DDQ</sub>	D14	Q14	Q5
<b>G</b>	D30	D22	Q22	V <sub>DDQ</sub>	V <sub>DD</sub>	V <sub>SS</sub>	V <sub>DD</sub>	V <sub>DDQ</sub>	Q13	D13	D5
<b>H</b>	DOFF	V <sub>REF</sub>	V <sub>DDQ</sub>	V <sub>DDQ</sub>	V <sub>DD</sub>	V <sub>SS</sub>	V <sub>DD</sub>	V <sub>DDQ</sub>	V <sub>DDQ</sub>	V <sub>REF</sub>	ZQ
<b>J</b>	D31	Q31	D23	V <sub>DDQ</sub>	V <sub>DD</sub>	V <sub>SS</sub>	V <sub>DD</sub>	V <sub>DDQ</sub>	D12	Q4	D4
<b>K</b>	Q32	D32	Q23	V <sub>DDQ</sub>	V <sub>DD</sub>	V <sub>SS</sub>	V <sub>DD</sub>	V <sub>DDQ</sub>	Q12	D3	Q3
<b>L</b>	Q33	Q24	D24	V <sub>DDQ</sub>	V <sub>SS</sub>	V <sub>SS</sub>	V <sub>SS</sub>	V <sub>DDQ</sub>	D11	Q11	Q2
<b>M</b>	D33	Q34	D25	V <sub>SS</sub>	V <sub>SS</sub>	V <sub>SS</sub>	V <sub>SS</sub>	V <sub>SS</sub>	D10	Q1	D2
<b>N</b>	D34	D26	Q25	V <sub>SS</sub>	A	A	A	V <sub>SS</sub>	Q10	D9	D1
<b>P</b>	Q35	D35	Q26	A	A	C	A	A	Q9	D0	Q0
<b>R</b>	TDO	TCK	A	A	A	C	A	A	A	TMS	TDI

**Note**

1. V<sub>SS</sub>/144 M and V<sub>SS</sub>/288 M are not connected to the die and can be tied to any voltage level.

## Pin Definitions

Pin Name	I/O	Pin Description
$D_{[x:0]}$	Input-Synchronous	<b>Data Input Signals.</b> Sampled on the rising edge of K and $\bar{K}$ clocks during valid write operations. CY7C1512V18 – $D_{[17:0]}$ CY7C1514V18 – $D_{[35:0]}$
$\overline{WPS}$	Input-Synchronous	<b>Write Port Select – Active LOW.</b> Sampled on the rising edge of the K clock. When asserted active, a write operation is initiated. Deasserting deselects the write port. Deselecting the write port ignores $D_{[x:0]}$ .
$\overline{BWS}_0$ , $\overline{BWS}_1$ , $\overline{BWS}_2$ , $\overline{BWS}_3$	Input-Synchronous	<b>Byte Write Select 0, 1, 2, and 3 – Active LOW.</b> Sampled on the rising edge of the K and $\bar{K}$ clocks during write operations. Used to select which byte is written into the device during the current portion of the write operations. Bytes not written remain unaltered. CY7C1512V18 – $\overline{BWS}_0$ controls $D_{[8:0]}$ and $\overline{BWS}_1$ controls $D_{[17:9]}$ . CY7C1514V18 – $\overline{BWS}_0$ controls $D_{[8:0]}$ , $\overline{BWS}_1$ controls $D_{[17:9]}$ , $\overline{BWS}_2$ controls $D_{[26:18]}$ and $\overline{BWS}_3$ controls $D_{[35:27]}$ . All the Byte Write Selects are sampled on the same edge as the data. Deselecting a Byte Write Select ignores the corresponding byte of data and it is not written into the device.
A	Input-Synchronous	<b>Address Inputs.</b> Sampled on the rising edge of the K (read address) and $\bar{K}$ (write address) clocks during active read and write operations. These address inputs are multiplexed for both read and write operations. Internally, the device is organized as 4 M × 18 (2 arrays each of 2 M × 18) for CY7C1512V18, and 2 M × 36 (2 arrays each of 1 M × 36) for CY7C1514V18. Therefore, only 21 address inputs are needed to access the entire memory array of CY7C1512V18 and 20 address inputs for CY7C1514V18. These inputs are ignored when the appropriate port is deselected.
$Q_{[x:0]}$	Output-Synchronous	<b>Data Output Signals.</b> These pins drive out the requested data during a read operation. Valid data is driven out on the rising edge of the C and $\bar{C}$ clocks during read operations, or K and $\bar{K}$ when in single clock mode. When the read port is deselected, $Q_{[x:0]}$ are automatically tristated. CY7C1512V18 – $Q_{[17:0]}$ CY7C1514V18 – $Q_{[35:0]}$
$\overline{RPS}$	Input-Synchronous	<b>Read Port Select – Active LOW.</b> Sampled on the rising edge of positive input clock (K). When active, a read operation is initiated. Deasserting deselects the read port. When deselected, the pending access is allowed to complete and the output drivers are automatically tristated following the next rising edge of the C clock. Each read access consists of a burst of four sequential transfers.
C	Input Clock	<b>Positive Input Clock for Output Data.</b> C is used in conjunction with $\bar{C}$ to clock out the read data from the device. Use C and $\bar{C}$ together to deskew the flight times of various devices on the board back to the controller. See <a href="#">Application Example on page 8</a> for further details.
$\bar{C}$	Input Clock	<b>Negative Input Clock for Output Data.</b> $\bar{C}$ is used in conjunction with C to clock out the read data from the device. Use C and $\bar{C}$ together to deskew the flight times of various devices on the board back to the controller. See <a href="#">Application Example on page 8</a> for further details.
K	Input Clock	<b>Positive Input Clock Input.</b> The rising edge of K is used to capture synchronous inputs to the device and to drive out data through $Q_{[x:0]}$ when in single clock mode. All accesses are initiated on the rising edge of K.
$\bar{K}$	Input Clock	<b>Negative Input Clock Input.</b> $\bar{K}$ is used to capture synchronous inputs being presented to the device and to drive out data through $Q_{[x:0]}$ when in single clock mode.
CQ	Echo Clock	<b>CQ Referenced with Respect to C.</b> This is a free-running clock and is synchronized to the input clock for output data (C) of the QDR II. In single clock mode, CQ is generated with respect to K. The timing for the echo clocks is shown in <a href="#">Switching Characteristics on page 22</a> .
$\bar{CQ}$	Echo Clock	<b>CQ Referenced with Respect to <math>\bar{C}</math>.</b> This is a free-running clock and is synchronized to the input clock for output data ( $\bar{C}$ ) of the QDR II. In single clock mode, $\bar{CQ}$ is generated with respect to $\bar{K}$ . The timing for the echo clocks is shown in the <a href="#">Switching Characteristics on page 22</a> .
ZQ	Input	<b>Output Impedance Matching Input.</b> This input is used to tune the device outputs to the system data bus impedance. CQ, $\bar{CQ}$ , and $Q_{[x:0]}$ output impedance are set to $0.2 \times RQ$ , where RQ is a resistor connected between ZQ and ground. Alternatively, connect this pin directly to $V_{DDQ}$ , which enables the minimum impedance mode. This pin cannot be connected directly to GND or left unconnected.

**Pin Definitions** (continued)

Pin Name	I/O	Pin Description
DOFF	Input	<b>DLL Turn OFF – Active LOW.</b> Connecting this pin to ground turns off the DLL inside the device. The timing in the operation with the DLL turned OFF differs from those listed in this data sheet.
TDO	Output	<b>TDO for JTAG.</b>
TCK	Input	<b>TCK Pin for JTAG.</b>
TDI	Input	<b>TDI Pin for JTAG.</b>
TMS	Input	<b>TMS Pin for JTAG.</b>
NC	N/A	<b>Not Connected to the Die.</b> Can be tied to any voltage level.
V <sub>SS/144M</sub>	Input	<b>Address Expansion for 144 M.</b> Can be tied to any voltage level.
V <sub>SS/288M</sub>	Input	<b>Address Expansion for 288 M.</b> Can be tied to any voltage level.
V <sub>REF</sub>	Input-Reference	<b>Reference Voltage Input.</b> Static input used to set the reference level for HSTL inputs, outputs, and AC measurement points.
V <sub>DD</sub>	Power Supply	<b>Power Supply Inputs to the Core of the Device.</b>
V <sub>SS</sub>	Ground	<b>Ground for the Device.</b>
V <sub>DDQ</sub>	Power Supply	<b>Power Supply Inputs for the Outputs of the Device.</b>

## Functional Overview

The CY7C1512V18, and CY7C1514V18 are synchronous pipelined Burst SRAMs with a read port and a write port. The read port is dedicated to read operations and the write port is dedicated to write operations. Data flows into the SRAM through the write port and flows out through the read port. These devices multiplex the address inputs to minimize the number of address pins required. By having separate read and write ports, the QDR II completely eliminates the need to turnaround the data bus and avoids any possible data contention, thereby simplifying system design. Each access consists of two 18-bit data transfers in the case of CY7C1512V18, and two 36-bit data transfers in the case of CY7C1514V18 in one clock cycle.

Accesses for both ports are initiated on the rising edge of the positive input clock (K). All synchronous input timing is referenced from the rising edge of the input clocks (K and  $\bar{K}$ ) and all output timing is referenced to the output clocks (C and  $\bar{C}$ , or K and  $\bar{K}$  when in single clock mode).

All synchronous data inputs ( $D_{[x:0]}$ ) pass through input registers controlled by the input clocks (K and  $\bar{K}$ ). All synchronous data outputs ( $Q_{[x:0]}$ ) pass through output registers controlled by the rising edge of the output clocks (C and  $\bar{C}$ , or K and  $\bar{K}$  when in single clock mode).

All synchronous control ( $\overline{RPS}$ ,  $\overline{WPS}$ ,  $\overline{BWS}_{[x:0]}$ ) inputs pass through input registers controlled by the rising edge of the input clocks (K and  $\bar{K}$ ).

CY7C1512V18 is described in the following sections. The same basic descriptions apply to CY7C1514V18.

### Read Operations

The CY7C1512V18 is organized internally as two arrays of  $2\text{ M} \times 18$ . Accesses are completed in a burst of two sequential 18-bit data words. Read operations are initiated by asserting  $\overline{RPS}$  active at the rising edge of the positive input clock (K). The address is latched on the rising edge of the K clock. The address presented to the address inputs is stored in the read address register. Following the next K clock rise, the corresponding lowest order 18-bit word of data is driven onto the  $Q_{[17:0]}$  using C as the output timing reference. On the subsequent rising edge of C, the next 18-bit data word is driven onto the  $Q_{[17:0]}$ . The requested data is valid 0.45 ns from the rising edge of the output clock (C and  $\bar{C}$  or K and  $\bar{K}$  when in single clock mode).

Synchronous internal circuitry automatically tristates the outputs following the next rising edge of the output clocks (C/ $\bar{C}$ ). This enables for a seamless transition between devices without the insertion of wait states in a depth expanded memory.

### Write Operations

Write operations are initiated by asserting  $\overline{WPS}$  active at the rising edge of the positive input clock (K). On the same K clock rise the data presented to  $D_{[17:0]}$  is latched and stored into the lower 18-bit write data register, provided  $\overline{BWS}_{[1:0]}$  are both asserted active. On the subsequent rising edge of the negative input clock ( $\bar{K}$ ), the address is latched and the information presented to  $D_{[17:0]}$  is also stored into the write data register, provided  $\overline{BWS}_{[1:0]}$  are both asserted active. The 36-bits of data are then written into the memory array at the specified location.

When deselected, the write port ignores all inputs after the pending write operations have been completed.

### Byte Write Operations

Byte write operations are supported by the CY7C1512V18. A write operation is initiated as described in the [Write Operations](#) section. The bytes that are written are determined by  $\overline{BWS}_0$  and  $\overline{BWS}_1$ , which are sampled with each set of 18-bit data words. Asserting the appropriate Byte Write Select input during the data portion of a write latches the data being presented and writes it into the device. Deasserting the Byte write select input during the data portion of a write enables the data stored in the device for that byte to remain unaltered. This feature can be used to simplify read, modify, or write operations to a byte write operation.

### Single Clock Mode

The CY7C1510V18 can be used with a single clock that controls both the input and output registers. In this mode the device recognizes only a single pair of input clocks (K and  $\bar{K}$ ) that control both the input and output registers. This operation is identical to the operation if the device had zero skew between the K/ $\bar{K}$  and C/ $\bar{C}$  clocks. All timing parameters remain the same in this mode. To use this mode of operation, the user must tie C and  $\bar{C}$  HIGH at power on. This function is a strap option and not alterable during device operation.

### Concurrent Transactions

The read and write ports on the CY7C1512V18 operate completely independently of one another. As each port latches the address inputs on different clock edges, the user can read or write to any location, regardless of the transaction on the other port. The user can start reads and writes in the same clock cycle. If the ports access the same location at the same time, the SRAM delivers the most recent information associated with the specified address location. This includes forwarding data from a write cycle that was initiated on the previous K clock rise.

### Depth Expansion

The CY7C1512V18 has a port select input for each port. This enables for easy depth expansion. Both port selects are sampled on the rising edge of the positive input clock only (K). Each port select input can deselect the specified port. Deselecting a port does not affect the other port. All pending transactions (read and write) are completed before the device is deselected.

### Programmable Impedance

An external resistor,  $R_Q$ , must be connected between the ZQ pin on the SRAM and  $V_{SS}$  to enable the SRAM to adjust its output driver impedance. The value of  $R_Q$  must be 5X the value of the intended line impedance driven by the SRAM. The allowable range of  $R_Q$  to guarantee impedance matching with a tolerance of  $\pm 15\%$  is between  $175\ \Omega$  and  $350\ \Omega$ , with  $V_{DDQ} = 1.5\text{ V}$ . The output impedance is adjusted every 1024 cycles upon power-up to account for drifts in supply voltage and temperature.



### Echo Clocks

Echo clocks are provided on the QDR II to simplify data capture on high-speed systems. Two echo clocks are generated by the QDR II. CQ is referenced with respect to C and CQ is referenced with respect to C. These are free-running clocks and are synchronized to the output clock of the QDR II. In the single clock mode, CQ is generated with respect to K and CQ is generated with respect to K. The timing for the echo clocks is shown in [Switching Characteristics on page 22](#).

### DLL

These chips use a DLL that is designed to function between 120 MHz and the specified maximum clock frequency. During power-up, when the DOFF is tied HIGH, the DLL is locked after 1024 cycles of stable clock. The DLL can also be reset by slowing or stopping the input clocks K and K for a minimum of 30 ns. However, it is not necessary to reset the DLL to lock to the desired frequency. The DLL automatically locks 1024 clock cycles after a stable clock is presented. The DLL may be disabled by applying ground to the DOFF pin. For information refer to the application note, [DLL Considerations in QDRII/DDRII/QDRII+/DDRII+ – AN5062](#).

### Application Example

Figure 1 shows two QDR II used in an application.

Figure 1. Application Example

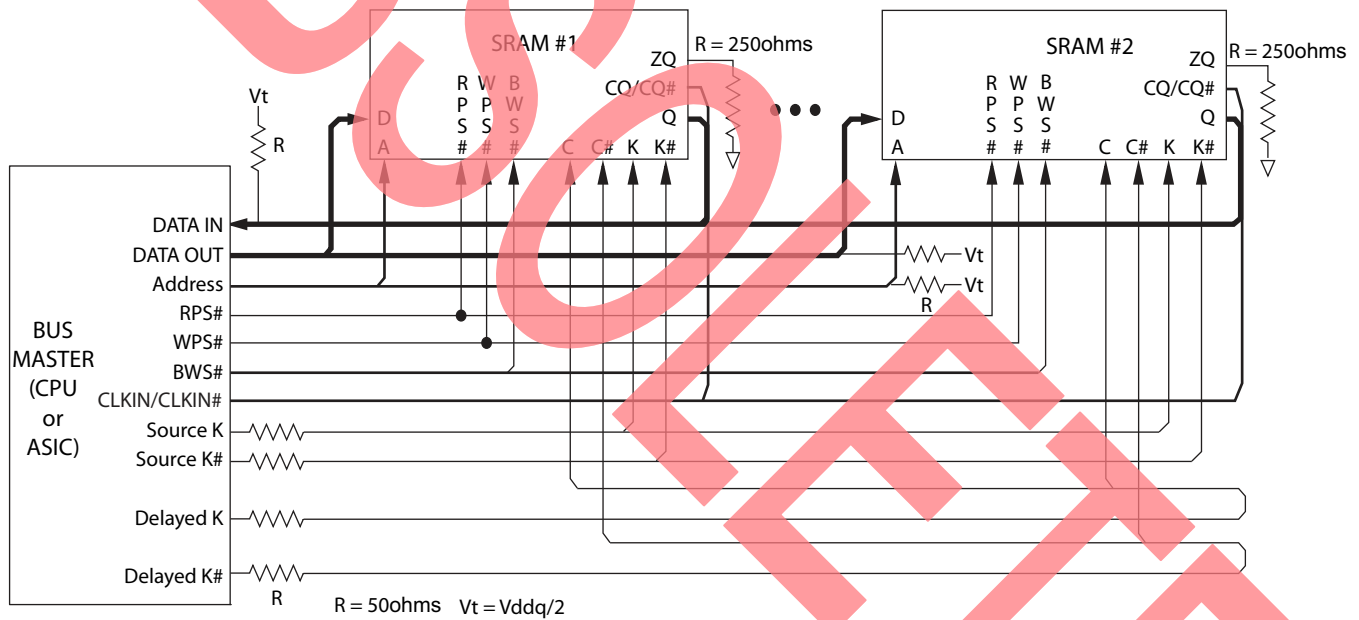

## Truth Table

The truth table for CY7C1512V18, and CY7C1514V18 follow. [2, 3, 4, 5, 6, 7]

Operation	K	$\overline{\text{RPS}}$	$\overline{\text{WPS}}$	DQ	DQ
Write cycle: Load address on the rising edge of $\overline{\text{K}}$ ; input write data on K and $\overline{\text{K}}$ rising edges.	L-H	X	L	D(A + 0) at K(t) $\uparrow$	D(A + 1) at $\overline{\text{K}}(t) \uparrow$
Read cycle: Load address on the rising edge of K; wait one and a half cycle; read data on $\overline{\text{C}}$ and C rising edges.	L-H	L	X	Q(A + 0) at $\overline{\text{C}}(t + 1) \uparrow$	Q(A + 1) at C(t + 2) $\uparrow$
NOP: No operation	L-H	H	H	D = X Q = High Z	D = X Q = High Z
Standby: Clock stopped	Stopped	X	X	Previous state	Previous state

## Write Cycle Descriptions

The write cycle description table for CY7C1512V18 follow. [2, 3]

$\overline{\text{BWS}}_0$	$\overline{\text{BWS}}_1$	K	$\overline{\text{K}}$	Comments
L	L	L-H	-	During the data portion of a write sequence: Both bytes ( $D_{[17:0]}$ ) are written into the device.
L	L	-	L-H	During the data portion of a write sequence: Both bytes ( $D_{[17:0]}$ ) are written into the device.
L	H	L-H	-	During the data portion of a write sequence: Only the lower byte ( $D_{[8:0]}$ ) is written into the device, $D_{[17:9]}$ remains unaltered.
L	H	-	L-H	During the data portion of a write sequence: Only the lower byte ( $D_{[8:0]}$ ) is written into the device, $D_{[17:9]}$ remains unaltered.
H	L	L-H	-	During the data portion of a write sequence: Only the upper byte ( $D_{[17:9]}$ ) is written into the device, $D_{[8:0]}$ remains unaltered.
H	L	-	L-H	During the data portion of a write sequence: Only the upper byte ( $D_{[17:9]}$ ) is written into the device, $D_{[8:0]}$ remains unaltered.
H	H	L-H	-	No data is written into the devices during this portion of a write operation.
H	H	-	L-H	No data is written into the devices during this portion of a write operation.

### Notes

- X = "Do not care," H = Logic HIGH, L = Logic LOW,  $\uparrow$  represents rising edge.
- Device powers up deselected with the outputs in a tristate condition.
- "A" represents address location latched by the devices when transaction was initiated. A + 0, A + 1 represents the internal address sequence in the burst.
- "t" represents the cycle at which a Read/Write operation is started. t + 1, and t + 2 are the first, and second clock cycles respectively succeeding the "t" clock cycle.
- Data inputs are registered at K and  $\overline{\text{K}}$  rising edges. Data outputs are delivered on C and  $\overline{\text{C}}$  rising edges, except when in single clock mode.
- It is recommended that K =  $\overline{\text{K}}$  and C =  $\overline{\text{C}}$  = HIGH when clock is stopped. This is not essential, but permits most rapid restart by overcoming transmission line charging symmetrically.
- Is based on a write cycle that was initiated in accordance with the Write Cycle Descriptions table.  $\overline{\text{BWS}}_0$ ,  $\overline{\text{BWS}}_1$ ,  $\overline{\text{BWS}}_2$  and  $\overline{\text{BWS}}_3$  can be altered on different portions of a write cycle, as long as the setup and hold requirements are achieved.

## Write Cycle Descriptions

The write cycle description table for CY7C1514V18 follow. [2, 8]

$\overline{BWS}_0$	$\overline{BWS}_1$	$\overline{BWS}_2$	$\overline{BWS}_3$	K	$\overline{K}$	Comments
L	L	L	L	L-H	-	During the data portion of a write sequence, all four bytes ( $D_{[35:0]}$ ) are written into the device.
L	L	L	L	-	L-H	During the data portion of a write sequence, all four bytes ( $D_{[35:0]}$ ) are written into the device.
L	H	H	H	L-H	-	During the data portion of a write sequence, only the lower byte ( $D_{[8:0]}$ ) is written into the device. $D_{[35:9]}$ remains unaltered.
L	H	H	H	-	L-H	During the data portion of a write sequence, only the lower byte ( $D_{[8:0]}$ ) is written into the device. $D_{[35:9]}$ remains unaltered.
H	L	H	H	L-H	-	During the data portion of a write sequence, only the byte ( $D_{[17:9]}$ ) is written into the device. $D_{[8:0]}$ and $D_{[35:18]}$ remains unaltered.
H	L	H	H	-	L-H	During the data portion of a write sequence, only the byte ( $D_{[17:9]}$ ) is written into the device. $D_{[8:0]}$ and $D_{[35:18]}$ remains unaltered.
H	H	L	H	L-H	-	During the data portion of a write sequence, only the byte ( $D_{[26:18]}$ ) is written into the device. $D_{[17:0]}$ and $D_{[35:27]}$ remains unaltered.
H	H	L	H	-	L-H	During the data portion of a write sequence, only the byte ( $D_{[26:18]}$ ) is written into the device. $D_{[17:0]}$ and $D_{[35:27]}$ remains unaltered.
H	H	H	L	L-H	-	During the data portion of a write sequence, only the byte ( $D_{[35:27]}$ ) is written into the device. $D_{[26:0]}$ remains unaltered.
H	H	H	L	-	L-H	During the data portion of a write sequence, only the byte ( $D_{[35:27]}$ ) is written into the device. $D_{[26:0]}$ remains unaltered.
H	H	H	H	L-H	-	No data is written into the device during this portion of a write operation.
H	H	H	H	-	L-H	No data is written into the device during this portion of a write operation.

## IEEE 1149.1 Serial Boundary Scan (JTAG)

These SRAMs incorporate a serial boundary scan Test Access Port (TAP) in the FBGA package. This part is fully compliant with IEEE Standard #1149.1-1900. The TAP operates using JEDEC standard 1.8 V I/O logic levels.

### Disabling the JTAG Feature

It is possible to operate the SRAM without using the JTAG feature. To disable the TAP controller, TCK must be tied LOW ( $V_{SS}$ ) to prevent clocking of the device. TDI and TMS are internally pulled up and may be unconnected. They may alternatively be connected to  $V_{DD}$  through a pull-up resistor. TDO must be left unconnected. Upon power-up, the device comes up in a reset state, which does not interfere with the operation of the device.

### Test Access Port—Test Clock

The test clock is used only with the TAP controller. All inputs are captured on the rising edge of TCK. All outputs are driven from the falling edge of TCK.

### Test Mode Select (TMS)

The TMS input is used to give commands to the TAP controller and is sampled on the rising edge of TCK. This pin may be left unconnected if the TAP is not used. The pin is pulled up internally, resulting in a logic HIGH level.

### Test Data-In (TDI)

The TDI pin is used to serially input information into the registers and can be connected to the input of any of the registers. The register between TDI and TDO is chosen by the instruction that is loaded into the TAP instruction register. For information on loading the instruction register, see the “TAP Controller State Diagram” on page 13. TDI is internally pulled up and can be unconnected if the TAP is unused in an application. TDI is connected to the most significant bit (MSB) on any register.

### Test Data-Out (TDO)

The TDO output pin is used to serially clock data out from the registers. The output is active, depending upon the current state of the TAP state machine (see “Instruction Codes” on page 16). The output changes on the falling edge of TCK. TDO is connected to the least significant bit (LSB) of any register.

### Performing a TAP Reset

A Reset is performed by forcing TMS HIGH ( $V_{DD}$ ) for five rising edges of TCK. This Reset does not affect the operation of the SRAM and can be performed while the SRAM is operating. At power-up, the TAP is reset internally to ensure that TDO comes up in a High Z state.

## TAP Registers

Registers are connected between the TDI and TDO pins to scan the data in and out of the SRAM test circuitry. Only one register can be selected at a time through the instruction registers. Data is serially loaded into the TDI pin on the rising edge of TCK. Data is output on the TDO pin on the falling edge of TCK.

### Instruction Register

Three-bit instructions can be serially loaded into the instruction register. This register is loaded when it is placed between the TDI and TDO pins, as shown in “TAP Controller Block Diagram” on page 14. Upon power-up, the instruction register is loaded with the IDCODE instruction. It is also loaded with the IDCODE instruction if the controller is placed in a reset state, as described in the previous section.

When the TAP controller is in the Capture-IR state, the two least significant bits are loaded with a binary “01” pattern to allow for fault isolation of the board level serial test path.

### Bypass Register

To save time when serially shifting data through registers, it is sometimes advantageous to skip certain chips. The bypass register is a single bit register that can be placed between TDI and TDO pins. This enables shifting of data through the SRAM with minimal delay. The bypass register is set LOW ( $V_{SS}$ ) when the BYPASS instruction is executed.

### Boundary Scan Register

The boundary scan register is connected to all of the input and output pins on the SRAM. Several No Connect (NC) pins are also included in the scan register to reserve pins for higher density devices.

The boundary scan register is loaded with the contents of the RAM input and output ring when the TAP controller is in the Capture-DR state and is then placed between the TDI and TDO pins when the controller is moved to the Shift-DR state. The EXTEST, SAMPLE/PRELOAD, and SAMPLE Z instructions can be used to capture the contents of the input and output ring.

The “Boundary Scan Order” on page 17 shows the order in which the bits are connected. Each bit corresponds to one of the bumps on the SRAM package. The MSB of the register is connected to TDI, and the LSB is connected to TDO.

### Identification (ID) Register

The ID register is loaded with a vendor-specific, 32-bit code during the Capture-DR state when the IDCODE command is loaded in the instruction register. The IDCODE is hardwired into the SRAM and can be shifted out when the TAP controller is in the Shift-DR state. The ID register has a vendor code and other information described in “Identification Register Definitions” on page 16.

## TAP Instruction Set

Eight different instructions are possible with the three-bit instruction register. All combinations are listed in “[Instruction Codes](#)” on page 16. Three of these instructions are listed as RESERVED and must not be used. The other five instructions are described in this section in detail.

Instructions are loaded into the TAP controller during the Shift-IR state when the instruction register is placed between TDI and TDO. During this state, instructions are shifted through the instruction register through the TDI and TDO pins. To execute the instruction after it is shifted in, the TAP controller must be moved into the Update-IR state.

### IDCODE

The IDCODE instruction loads a vendor-specific, 32-bit code into the instruction register. It also places the instruction register between the TDI and TDO pins and shifts the IDCODE out of the device when the TAP controller enters the Shift-DR state. The IDCODE instruction is loaded into the instruction register at power-up or whenever the TAP controller is supplied a Test-Logic-Reset state.

### SAMPLE Z

The SAMPLE Z instruction connects the boundary scan register between the TDI and TDO pins when the TAP controller is in a Shift-DR state. The SAMPLE Z command puts the output bus into a High Z state until the next command is supplied during the Update IR state.

### SAMPLE/PRELOAD

SAMPLE/PRELOAD is a 1149.1 mandatory instruction. When the SAMPLE/PRELOAD instructions are loaded into the instruction register and the TAP controller is in the Capture-DR state, a snapshot of data on the input and output pins is captured in the boundary scan register.

The user must be aware that the TAP controller clock can only operate at a frequency up to 20 MHz, while the SRAM clock operates more than an order of magnitude faster. Because there is a large difference in the clock frequencies, it is possible that during the Capture-DR state, an input or output undergoes a transition. The TAP may then try to capture a signal while in transition (metastable state). This does not harm the device, but there is no guarantee as to the value that is captured. Repeatable results may not be possible.

To guarantee that the boundary scan register captures the correct value of a signal, the SRAM signal must be stabilized long enough to meet the TAP controller's capture setup plus hold times ( $t_{CS}$  and  $t_{CH}$ ). The SRAM clock input might not be captured correctly if there is no way in a design to stop (or slow) the clock during a SAMPLE/PRELOAD instruction. If this is an issue, it is still possible to capture all other signals and simply ignore the value of the CK and  $\overline{CK}$  captured in the boundary scan register.

After the data is captured, it is possible to shift out the data by putting the TAP into the Shift-DR state. This places the boundary scan register between the TDI and TDO pins.

PRELOAD places an initial data pattern at the latched parallel outputs of the boundary scan register cells before the selection of another boundary scan test operation.

The shifting of data for the SAMPLE and PRELOAD phases can occur concurrently when required, that is, while the data captured is shifted out, the preloaded data can be shifted in.

### BYPASS

When the BYPASS instruction is loaded in the instruction register and the TAP is placed in a Shift-DR state, the bypass register is placed between the TDI and TDO pins. The advantage of the BYPASS instruction is that it shortens the boundary scan path when multiple devices are connected together on a board.

### EXTEST

The EXTEST instruction drives the preloaded data out through the system output pins. This instruction also connects the boundary scan register for serial access between the TDI and TDO in the Shift-DR controller state.

### EXTEST OUTPUT BUS TRISTATE

IEEE Standard 1149.1 mandates that the TAP controller be able to put the output bus into a tristate mode.

The boundary scan register has a special bit located at bit #108. When this scan cell, called the “extest output bus tristate,” is latched into the preload register during the Update-DR state in the TAP controller, it directly controls the state of the output (Q-bus) pins, when the EXTEST is entered as the current instruction. When HIGH, it enables the output buffers to drive the output bus. When LOW, this bit places the output bus into a High Z condition.

This bit can be set by entering the SAMPLE/PRELOAD or EXTEST command, and then shifting the desired bit into that cell, during the Shift-DR state. During Update-DR, the value loaded into that shift-register cell latches into the preload register. When the EXTEST instruction is entered, this bit directly controls the output Q-bus pins. Note that this bit is pre-set LOW to enable the output when the device is powered-up, and also when the TAP controller is in the Test-Logic-Reset state.

### Reserved

These instructions are not implemented but are reserved for future use. Do not use these instructions.

### TAP Controller State Diagram

The state diagram for the TAP controller follows. [9]

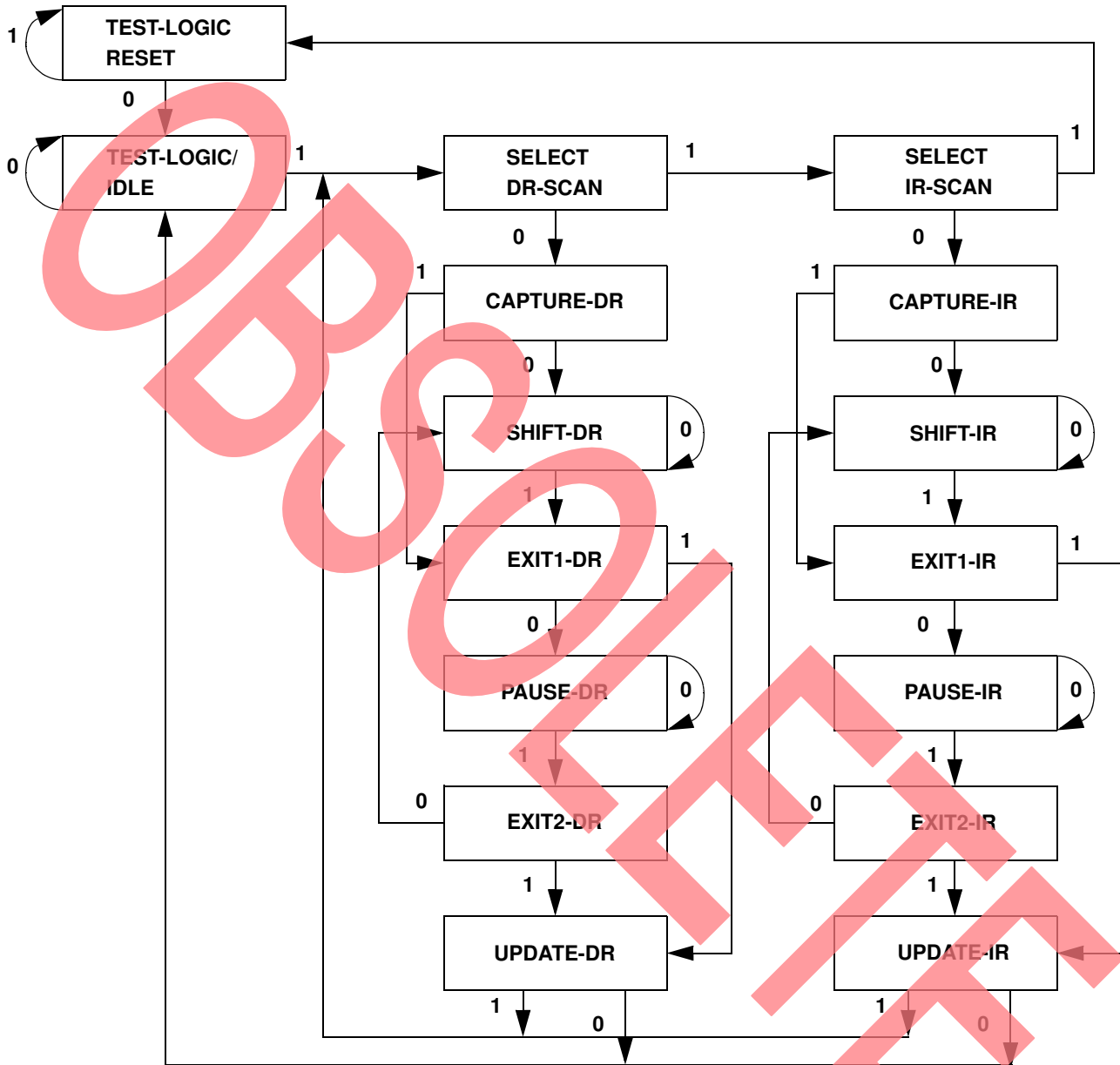

**Note**  
9. The 0/1 next to each state represents the value at TMS at the rising edge of TCK.

### TAP Controller Block Diagram

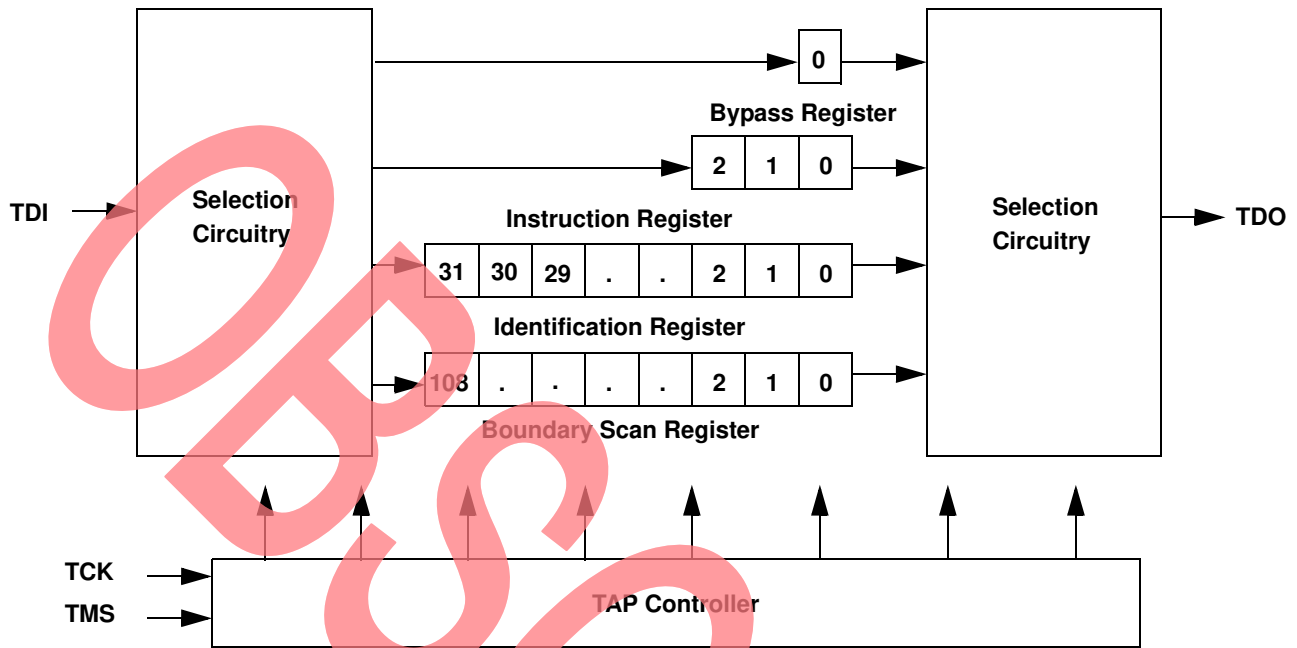

### TAP Electrical Characteristics

Over the Operating Range <sup>[10, 11, 12]</sup>

Parameter	Description	Test Conditions	Min	Max	Unit
V <sub>OH1</sub>	Output HIGH voltage	I <sub>OH</sub> = -2.0 mA	1.4		V
V <sub>OH2</sub>	Output HIGH voltage	I <sub>OH</sub> = -100 μA	1.6		V
V <sub>OL1</sub>	Output LOW voltage	I <sub>OL</sub> = 2.0 mA		0.4	V
V <sub>OL2</sub>	Output LOW voltage	I <sub>OL</sub> = 100 μA		0.2	V
V <sub>IH</sub>	Input HIGH voltage		0.65 V <sub>DD</sub>	V <sub>DD</sub> + 0.3	V
V <sub>IL</sub>	Input LOW voltage		-0.3	0.35 V <sub>DD</sub>	V
I <sub>X</sub>	Input and output load current	GND ≤ V <sub>I</sub> ≤ V <sub>DD</sub>	-5	5	μA

#### Notes

10. These characteristics pertain to the TAP inputs (TMS, TCK, TDI and TDO). Parallel load levels are specified in the [Electrical Characteristics](#) table.
11. Overshoot: V<sub>IH</sub>(AC) ≤ V<sub>DDQ</sub> + 0.85 V (Pulse width less than t<sub>CYC</sub>/2), Undershoot: V<sub>IL</sub>(AC) > -1.5 V (Pulse width less than t<sub>CYC</sub>/2).
12. All voltage referenced to Ground.

## TAP AC Switching Characteristics

Over the Operating Range [13, 14]

Parameter	Description	Min	Max	Unit
$t_{TCYC}$	TCK clock cycle time	50		ns
$t_{TF}$	TCK clock frequency		20	MHz
$t_{TH}$	TCK clock HIGH	20		ns
$t_{TL}$	TCK clock LOW	20		ns
<b>Setup Times</b>				
$t_{TMSS}$	TMS setup to TCK clock rise	5		ns
$t_{TDIS}$	TDI setup to TCK clock rise	5		ns
$t_{CS}$	Capture setup to TCK rise	5		ns
<b>Hold Times</b>				
$t_{TMSH}$	TMS hold after TCK clock rise	5		ns
$t_{TDIH}$	TDI hold after clock rise	5		ns
$t_{CH}$	Capture hold after clock rise	5		ns
<b>Output Times</b>				
$t_{TDOV}$	TCK clock LOW to TDO valid		10	ns
$t_{TDOX}$	TCK clock LOW to TDO invalid	0		ns

## TAP Timing and Test Conditions

Figure 2 shows the TAP timing and test conditions. [14]

Figure 2. TAP Timing and Test Conditions

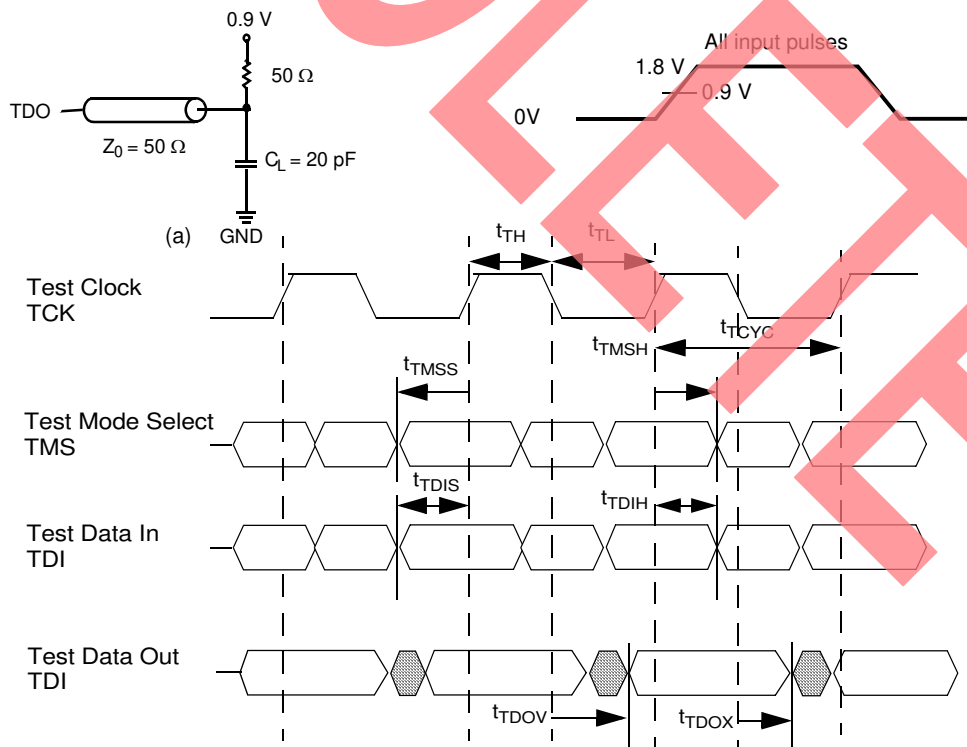

### Notes

- 13.  $t_{CS}$  and  $t_{CH}$  refer to the setup and hold time requirements of latching data from the boundary scan register.
- 14. Test conditions are specified using the load in TAP AC Test Conditions.  $t_P/t_F = 1$  ns.



### Identification Register Definitions

Instruction Field	Value		Description
	CY7C1512V18	CY7C1514V18	
Revision Number (31:29)	000	000	Version number.
Cypress Device ID (28:12)	11010011010010100	11010011010100100	Defines the type of SRAM.
Cypress JEDEC ID (11:1)	00000110100	00000110100	Allows unique identification of SRAM vendor.
ID Register Presence (0)	1	1	Indicates the presence of an ID register.

### Scan Register Sizes

Register Name	Bit Size
Instruction	3
Bypass	1
ID	32
Boundary Scan	109

### Instruction Codes

Instruction	Code	Description
EXTEST	000	Captures the input and output ring contents.
IDCODE	001	Loads the ID register with the vendor ID code and places the register between TDI and TDO. This operation does not affect SRAM operation.
SAMPLE Z	010	Captures the input and output contents. Places the boundary scan register between TDI and TDO. Forces all SRAM output drivers to a High Z state.
RESERVED	011	Do Not Use: This instruction is reserved for future use.
SAMPLE/PRELOAD	100	Captures the input and output contents. Places the boundary scan register between TDI and TDO. Does not affect the SRAM operation.
RESERVED	101	Do Not Use: This instruction is reserved for future use.
RESERVED	110	Do Not Use: This instruction is reserved for future use.
BYPASS	111	Places the bypass register between TDI and TDO. This operation does not affect SRAM operation.

**Boundary Scan Order**

Bit #	Bump ID	Bit #	Bump ID	Bit #	Bump ID	Bit #	Bump ID
0	6R	28	10G	56	6A	84	1J
1	6P	29	9G	57	5B	85	2J
2	6N	30	11F	58	5A	86	3K
3	7P	31	11G	59	4A	87	3J
4	7N	32	9F	60	5C	88	2K
5	7R	33	10F	61	4B	89	1K
6	8R	34	11E	62	3A	90	2L
7	8P	35	10E	63	2A	91	3L
8	9R	36	10D	64	1A	92	1M
9	11P	37	9E	65	2B	93	1L
10	10P	38	10C	66	3B	94	3N
11	10N	39	11D	67	1C	95	3M
12	9P	40	9C	68	1B	96	1N
13	10M	41	9D	69	3D	97	2M
14	11N	42	11B	70	3C	98	3P
15	9M	43	11C	71	1D	99	2N
16	9N	44	9B	72	2C	100	2P
17	11L	45	10B	73	3E	101	1P
18	11M	46	11A	74	2D	102	3R
19	9L	47	10A	75	2E	103	4R
20	10L	48	9A	76	1E	104	4P
21	11K	49	8B	77	2F	105	5P
22	10K	50	7C	78	3F	106	5N
23	9J	51	6C	79	1G	107	5R
24	9K	52	8A	80	1F	108	Internal
25	10J	53	7A	81	3G		
26	11J	54	7B	82	2G		
27	11H	55	6B	83	1H		

## Power-up Sequence in QDR II SRAM

QDR II SRAMs must be powered-up and initialized in a predefined manner to prevent undefined operations.

### Power-up Sequence

- Apply power and drive  $\overline{\text{DOFF}}$  either HIGH or LOW (All other inputs can be HIGH or LOW).
  - Apply  $V_{\text{DD}}$  before  $V_{\text{DDQ}}$ .
  - Apply  $V_{\text{DDQ}}$  before  $V_{\text{REF}}$  or at the same time as  $V_{\text{REF}}$ .
  - Drive  $\overline{\text{DOFF}}$  HIGH.
- Provide stable  $\overline{\text{DOFF}}$  (HIGH), power and clock (K,  $\overline{\text{K}}$ ) for 1024 cycles to lock the DLL.

### DLL Constraints

- DLL uses K clock as its synchronizing input. The input must have low phase jitter, which is specified as  $t_{\text{KC Var}}$ .
- The DLL functions at frequencies down to 120 MHz.
- If the input clock is unstable and the DLL is enabled, then the DLL may lock onto an incorrect frequency, causing unstable SRAM behavior. To avoid this, provide 1024 cycles stable clock to relock to the desired clock frequency.

Figure 3. Power-up Waveforms

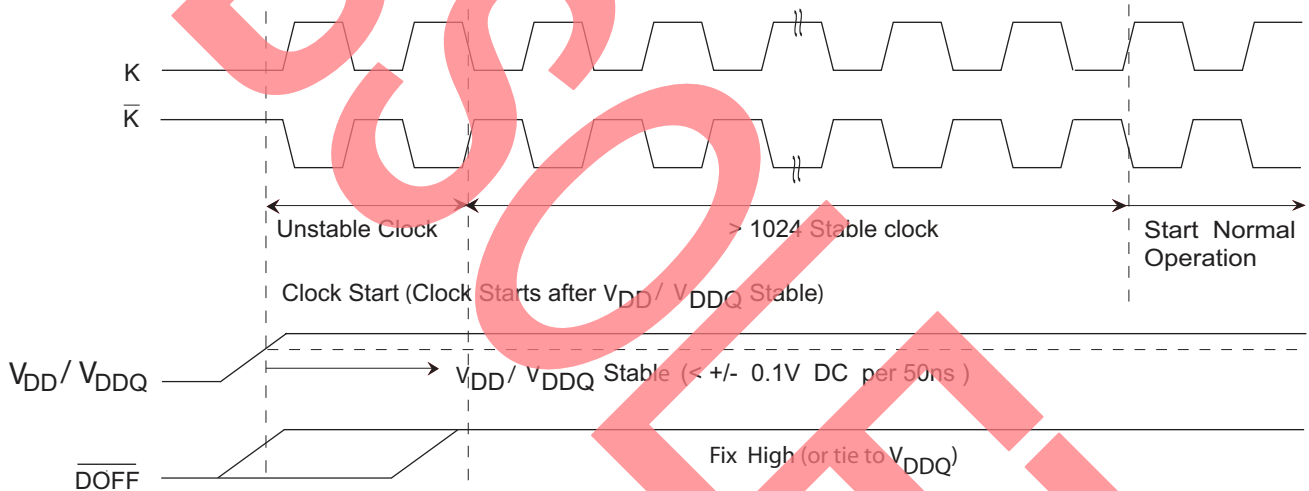

## Maximum Ratings

Exceeding maximum ratings may shorten the useful life of the device. User guidelines are not tested.

Storage temperature ..... -65 °C to +150 °C  
 Ambient temperature with power applied . -55 °C to +125 °C  
 Supply voltage on  $V_{DD}$  relative to GND ..... -0.5 V to +2.9 V  
 Supply voltage on  $V_{DDQ}$  relative to GND ..... -0.5 V to + $V_{DD}$   
 DC applied to outputs in high Z ..... -0.5 V to  $V_{DDQ}$  + 0.5 V  
 DC input voltage <sup>[11]</sup> ..... -0.5 V to  $V_{DD}$  + 0.5 V  
 Current into outputs (LOW) ..... 20 mA  
 Static discharge voltage (MIL-STD-883, M. 3015) .. > 2001 V  
 Latch-up current ..... > 200 mA

## Operating Range

Range	Ambient Temperature ( $T_A$ )	$V_{DD}$ <sup>[15]</sup>	$V_{DDQ}$ <sup>[15]</sup>
Commercial	0 °C to +70 °C	1.8 ± 0.1 V	1.4 V to $V_{DD}$
Industrial	-40 °C to +85 °C		

## Electrical Characteristics

### DC Electrical Characteristics

Over the Operating Range <sup>[12]</sup>

Parameter	Description	Test Conditions	Min	Typ	Max	Unit
$V_{DD}$	Power supply voltage		1.7	1.8	1.9	V
$V_{DDQ}$	I/O supply voltage		1.4	1.5	$V_{DD}$	V
$V_{OH}$	Output HIGH voltage	Note 16	$V_{DDQ}/2 - 0.12$		$V_{DDQ}/2 + 0.12$	V
$V_{OL}$	Output LOW voltage	Note 17	$V_{DDQ}/2 - 0.12$		$V_{DDQ}/2 + 0.12$	V
$V_{OH(LOW)}$	Output HIGH voltage	$I_{OH} = -0.1$ mA, nominal impedance	$V_{DDQ} - 0.2$		$V_{DDQ}$	V
$V_{OL(LOW)}$	Output LOW voltage	$I_{OL} = 0.1$ mA, nominal impedance	$V_{SS}$		0.2	V
$V_{IH}$	Input HIGH voltage		$V_{REF} + 0.1$		$V_{DDQ} + 0.3$	V
$V_{IL}$	Input LOW voltage		-0.3		$V_{REF} - 0.1$	V
$I_X$	Input leakage current	$GND \leq V_I \leq V_{DDQ}$	-5		5	μA
$I_{OZ}$	Output leakage current	$GND \leq V_I \leq V_{DDQ}$ , output disabled	-5		5	μA
$V_{REF}$	Input reference voltage <sup>[18]</sup>	Typical Value = 0.75V	0.68	0.75	0.95	V
$I_{DD}$ <sup>[19]</sup>	$V_{DD}$ operating supply	$V_{DD} = \text{Max}$ , $I_{OUT} = 0$ mA, $f = f_{MAX} = 1/t_{CYC}$				mA
		250 MHz (x18)			900	
		(x36)			1100	
		200 MHz (x18)			800	
		(x36)			900	
		167 MHz (x18)			750	
		(x36)			800	

### Notes

- Power-up: Assumes a linear ramp from 0 V to  $V_{DD}(\text{min})$  within 200 ms. During this time  $V_{IH} < V_{DD}$  and  $V_{DDQ} \leq V_{DD}$ .
- Output are impedance controlled.  $I_{OH} = -(V_{DDQ}/2)/(RQ/5)$  for values of 175 ohms  $\leq RQ \leq 350$  ohms.
- Output are impedance controlled.  $I_{OL} = (V_{DDQ}/2)/(RQ/5)$  for values of 175 ohms  $\leq RQ \leq 350$  ohms.
- $V_{REF}(\text{min}) = 0.68$  V or  $0.46 V_{DDQ}$ , whichever is larger,  $V_{REF}(\text{max}) = 0.95$  V or  $0.54 V_{DDQ}$ , whichever is smaller.
- The operation current is calculated with 50% read cycle and 50% write cycle.

## Neutron Soft Error Immunity

Parameter	Description	Test Conditions	Typ	Max*	Unit
LSBU	Logical single-bit upsets	25 °C	320	368	FIT/Mb
LMBU	Logical multi-bit upsets	25 °C	0	0.01	FIT/Mb
SEL	Single event latch-up	85 °C	0	0.1	FIT/Dev

\* No LMBU or SEL events occurred during testing; this column represents a statistical  $\chi^2$ , 95% confidence limit calculation. For more details refer to Application Note, Accelerated Neutron SER Testing and Calculation of Terrestrial Failure Rates – AN54908.

**Electrical Characteristics** (continued)

**DC Electrical Characteristics**

Over the Operating Range <sup>[12]</sup>

Parameter	Description	Test Conditions	Min	Typ	Max	Unit	
I <sub>SB1</sub>	Automatic power down current	Max V <sub>DD</sub> , Both ports deselected, V <sub>IN</sub> ≥ V <sub>IH</sub> or V <sub>IN</sub> ≤ V <sub>IL</sub> f = f <sub>MAX</sub> = 1/t <sub>CYC</sub> , inputs static	250 MHz	(x18)		400	mA
				(x36)		450	
			200 MHz	(x18)		380	
				(x36)		400	
			167 MHz	(x18)		360	
				(x36)		370	

**AC Electrical Characteristics**

Over the Operating Range <sup>[11]</sup>

Parameter	Description	Test Conditions	Min	Typ	Max	Unit
V <sub>IH</sub>	Input HIGH voltage		V <sub>REF</sub> + 0.2	–	–	V
V <sub>IL</sub>	Input LOW voltage		–	–	V <sub>REF</sub> – 0.2	V

## Capacitance

Tested initially and after any design or process change that may affect these parameters.

Parameter	Description	Test Conditions	Max	Unit
$C_{IN}$	Input capacitance	$T_A = 25\text{ }^\circ\text{C}$ , $f = 1\text{ MHz}$ , $V_{DD} = 1.8\text{ V}$ , $V_{DDQ} = 1.5\text{ V}$	5.5	pF
$C_{CLK}$	Clock input capacitance		8.5	pF
$C_O$	Output capacitance		6	pF

## Thermal Resistance

Tested initially and after any design or process change that may affect these parameters.

Parameter	Description	Test Conditions	165 FBGA Package	Unit
$\Theta_{JA}$	Thermal resistance (junction to ambient)	Test conditions follow standard test methods and procedures for measuring thermal impedance, in accordance with EIA/JESD51.	16.3	$^\circ\text{C/W}$
$\Theta_{JC}$	Thermal resistance (junction to case)		2.1	$^\circ\text{C/W}$

Figure 4. AC Test Loads and Waveforms

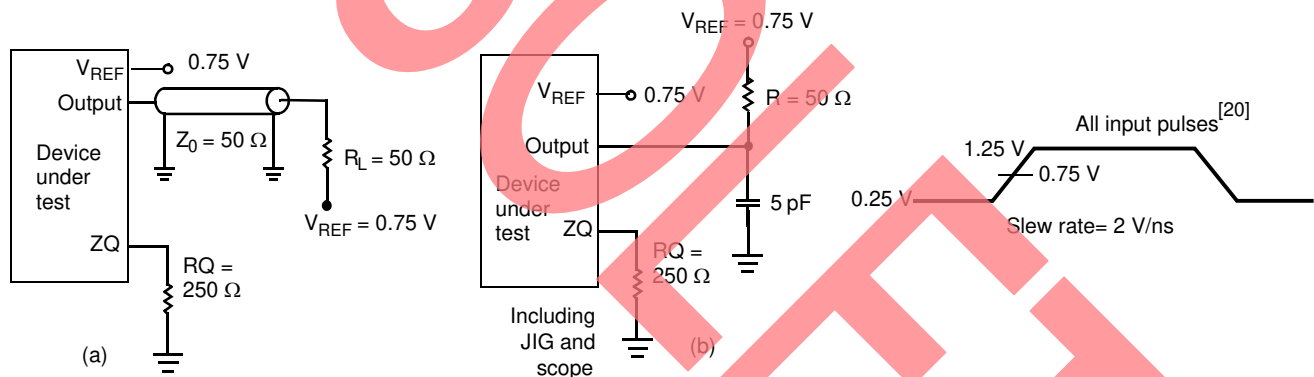

### Note

20. Unless otherwise noted, test conditions are based on signal transition time of 2 V/ns, timing reference levels of 0.75 V,  $V_{REF} = 0.75\text{ V}$ ,  $R_Q = 250\text{ }\Omega$ ,  $V_{DDQ} = 1.5\text{ V}$ , input pulse levels of 0.25 V to 1.25 V, and output loading of the specified  $I_{OL}/I_{OH}$  and load capacitance shown in (a) of AC Test Loads and Waveforms.

## Switching Characteristics

Over the Operating Range [20, 21]

Cypress Parameter	Consortium Parameter	Description	250 MHz		200 MHz		167 MHz		Unit
			Min	Max	Min	Max	Min	Max	
t <sub>POWER</sub>		V <sub>DD</sub> (Typical) to the first access [22]	1		1		1		ms
t <sub>CYC</sub>	t <sub>KHKH</sub>	K clock and C clock cycle time	4.0	8.4	5.0	8.4	6.0	8.4	ns
t <sub>KH</sub>	t <sub>KHKL</sub>	Input clock (K/ $\bar{K}$ ; C/ $\bar{C}$ ) HIGH	1.6	–	2.0	–	2.4	–	ns
t <sub>KL</sub>	t <sub>KLKH</sub>	Input clock (K/ $\bar{K}$ ; C/ $\bar{C}$ ) LOW	1.6	–	2.0	–	2.4	–	ns
t <sub>KH<math>\bar{K}</math>H</sub>	t <sub>K<math>\bar{H}</math>K<math>\bar{H}</math></sub>	K clock rise to $\bar{K}$ clock rise and C to $\bar{C}$ Rise (rising edge to rising edge)	1.8	–	2.2	–	2.7	–	ns
t <sub>KHCH</sub>	t <sub>K<math>\bar{H}</math>CH</sub>	K/ $\bar{K}$ clock rise to C/ $\bar{C}$ clock rise (rising edge to rising edge)	0	1.8	0	2.2	0	2.7	ns
<b>Setup Times</b>									
t <sub>SA</sub>	t <sub>AVKH</sub>	Address setup to (K/ $\bar{K}$ ) clock rise	0.35	–	0.4	–	0.5	–	ns
t <sub>SC</sub>	t <sub>IVKH</sub>	Control setup to K clock rise (RPS, WPS)	0.35	–	0.4	–	0.5	–	ns
t <sub>SCDDR</sub>	t <sub>IVKH</sub>	DDR control setup to clock (K/ $\bar{K}$ ) rise (BWS <sub>0</sub> , BWS <sub>1</sub> , BWS <sub>2</sub> , BWS <sub>3</sub> )	0.35	–	0.4	–	0.5	–	ns
t <sub>SD</sub> [23]	t <sub>DVKH</sub>	D <sub>[X:0]</sub> setup to clock (K/ $\bar{K}$ ) rise	0.35	–	0.4	–	0.5	–	ns
<b>Hold Times</b>									
t <sub>HA</sub>	t <sub>KHAX</sub>	Address hold after (K/ $\bar{K}$ ) clock rise	0.35	–	0.4	–	0.5	–	ns
t <sub>HC</sub>	t <sub>KHIX</sub>	Control hold after K clock rise (RPS, WPS)	0.35	–	0.4	–	0.5	–	ns
t <sub>HCDDR</sub>	t <sub>KHIX</sub>	DDR control hold after clock (K/ $\bar{K}$ ) rise (BWS <sub>0</sub> , BWS <sub>1</sub> , BWS <sub>2</sub> , BWS <sub>3</sub> )	0.35	–	0.4	–	0.5	–	ns
t <sub>HD</sub>	t <sub>KHDX</sub>	D <sub>[X:0]</sub> hold after clock (K/ $\bar{K}$ ) rise	0.35	–	0.4	–	0.5	–	ns
<b>Output Times</b>									
t <sub>CO</sub>	t <sub>CHQV</sub>	C/ $\bar{C}$ clock rise (or K/ $\bar{K}$ in single clock mode) to data valid	–	0.45	–	0.45	–	0.50	ns
t <sub>DOH</sub>	t <sub>CHQX</sub>	Data output hold after output C/ $\bar{C}$ clock rise (active to active)	–0.45	–	–0.45	–	–0.50	–	ns
t <sub>CCQO</sub>	t <sub>CHCQV</sub>	C/ $\bar{C}$ clock rise to echo clock valid	–	0.45	–	0.45	–	0.50	ns
t <sub>CQOH</sub>	t <sub>CHCQX</sub>	Echo clock hold after C/ $\bar{C}$ clock rise	–0.45	–	–0.45	–	–0.50	–	ns
t <sub>CQD</sub>	t <sub>CQHCV</sub>	Echo clock high to data valid	–	0.30	–	0.35	–	0.40	ns
t <sub>CQDOH</sub>	t <sub>CQHCV</sub>	Echo clock high to data invalid	–0.30	–	–0.35	–	–0.40	–	ns
t <sub>CHZ</sub>	t <sub>CHQZ</sub>	Clock (C/ $\bar{C}$ ) rise to high Z (active to high Z) [24, 25]	–	0.45	–	0.45	–	0.50	ns
t <sub>CLZ</sub>	t <sub>CHQX1</sub>	Clock (C/ $\bar{C}$ ) rise to low Z [24, 25]	–0.45	–	–0.45	–	–0.50	–	ns
<b>DLL Timing</b>									
t <sub>KC Var</sub>	t <sub>KC Var</sub>	Clock phase jitter	–	0.20	–	0.20	–	0.20	ns
t <sub>KC lock</sub>	t <sub>KC lock</sub>	DLL lock time (K, C)	1024	–	1024	–	1024	–	Cycles
t <sub>KC Reset</sub>	t <sub>KC Reset</sub>	K static to DLL reset	30	–	30	–	30	–	ns

### Notes

21. When a part with a maximum frequency above 167 MHz is operating at a lower clock frequency, it requires the input timings of the frequency range in which it is being operated and outputs data with the output timings of that frequency range.
22. This part has a voltage regulator internally; t<sub>POWER</sub> is the time that the power must be supplied above V<sub>DD</sub> minimum initially before initiating a read or write operation.
23. For D0 data signal on CY7C1525V18 device, t<sub>SD</sub> is 0.5 ns for 200 MHz, and 250 MHz frequencies.
24. t<sub>CHZ</sub>, t<sub>CLZ</sub> are specified with a load capacitance of 5 pF as in part (b) of AC Test Loads and Waveforms on page 21. Transition is measured ± 100 mV from steady state voltage.
25. At any voltage and temperature t<sub>CHZ</sub> is less than t<sub>CLZ</sub> and t<sub>CHZ</sub> less than t<sub>CO</sub>.

## Switching Waveforms

Figure 5. Read/Write/Deselect Sequence [26, 27, 28]

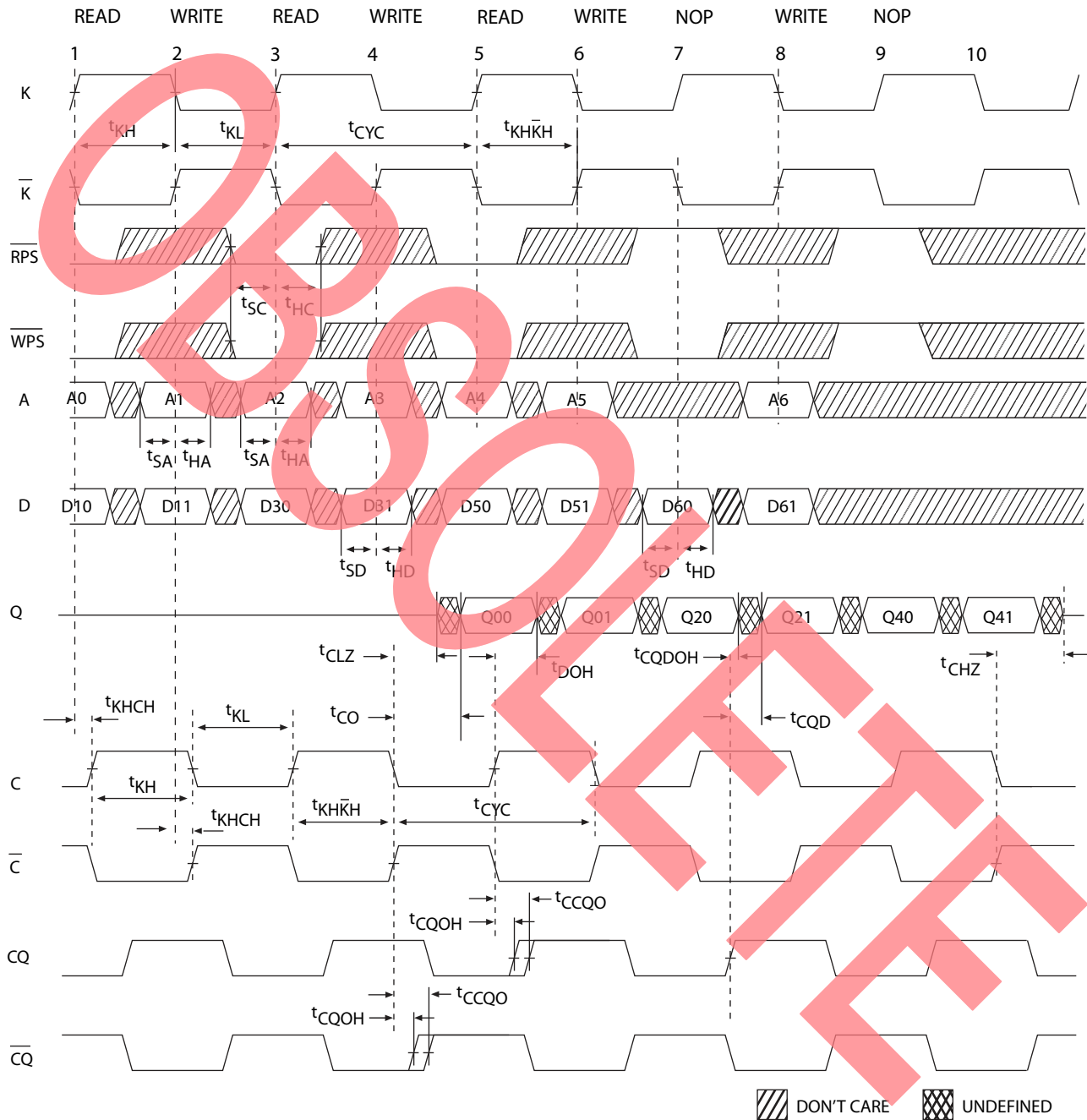

### Notes

26. Q00 refers to output from address A0. Q01 refers to output from the next internal burst address following A0, that is, A0+1.

27. Outputs are disabled (High Z) one clock cycle after a NOP.

28. In this example, if address A0 = A1, then data Q00 = D10 and Q01 = D11. Write data is forwarded immediately as read results. This note applies to the whole diagram.



## Ordering Information

The table below contains only the parts that are currently available. If you don't see what you are looking for, please contact your local sales representative. For more information, visit the Cypress website at [www.cypress.com](http://www.cypress.com) and refer to the product summary page at <http://www.cypress.com/products>

Cypress maintains a worldwide network of offices, solution centers, manufacturer's representatives and distributors. To find the office closest to you, visit us at <http://www.cypress.com/go/datasheet/offices>.

**Table 3. Ordering Information**

Speed (MHz)	Ordering Code	Package Diagram	Package Type	Operating Range
250	CY7C1512V18-250BZC	51-85195	165-Ball Fine Pitch Ball Grid Array (15 × 17 × 1.4 mm)	Commercial
	CY7C1514V18-250BZC			
	CY7C1512V18-250BZXC	51-85195	165-Ball Fine Pitch Ball Grid Array (15 × 17 × 1.4 mm) Pb-Free	Industrial
	CY7C1512V18-250BZL	51-85195	165-Ball Fine Pitch Ball Grid Array (15 × 17 × 1.4 mm)	
	CY7C1514V18-250BZL	51-85195	165-Ball Fine Pitch Ball Grid Array (15 × 17 × 1.4 mm) Pb-Free	
	CY7C1512V18-250BZXI			
200	CY7C1512V18-200BZC	51-85195	165-Ball Fine Pitch Ball Grid Array (15 × 17 × 1.4 mm)	Commercial
	CY7C1514V18-200BZC			
	CY7C1512V18-200BZXC	51-85195	165-Ball Fine Pitch Ball Grid Array (15 × 17 × 1.4 mm) Pb-Free	Industrial
	CY7C1514V18-200BZXC	51-85195	165-Ball Fine Pitch Ball Grid Array (15 × 17 × 1.4 mm)	
	CY7C1512V18-200BZL			
	CY7C1512V18-200BZXI	51-85195	165-Ball Fine Pitch Ball Grid Array (15 × 17 × 1.4 mm) Pb-Free	
	167	CY7C1512V18-167BZC	51-85195	165-Ball Fine Pitch Ball Grid Array (15 × 17 × 1.4 mm)
CY7C1514V18-167BZC				
CY7C1512V18-167BZXC		51-85195	165-Ball Fine Pitch Ball Grid Array (15 × 17 × 1.4 mm) Pb-Free	Industrial
CY7C1514V18-167BZXC		51-85195	165-Ball Fine Pitch Ball Grid Array (15 × 17 × 1.4 mm)	
CY7C1514V18-167BZL				
CY7C1512V18-167BZXI		51-85195	165-Ball Fine Pitch Ball Grid Array (15 × 17 × 1.4 mm) Pb-Free	

## Package Diagram

Figure 6. 165-Ball FBGA (15 × 17 × 1.4 mm)

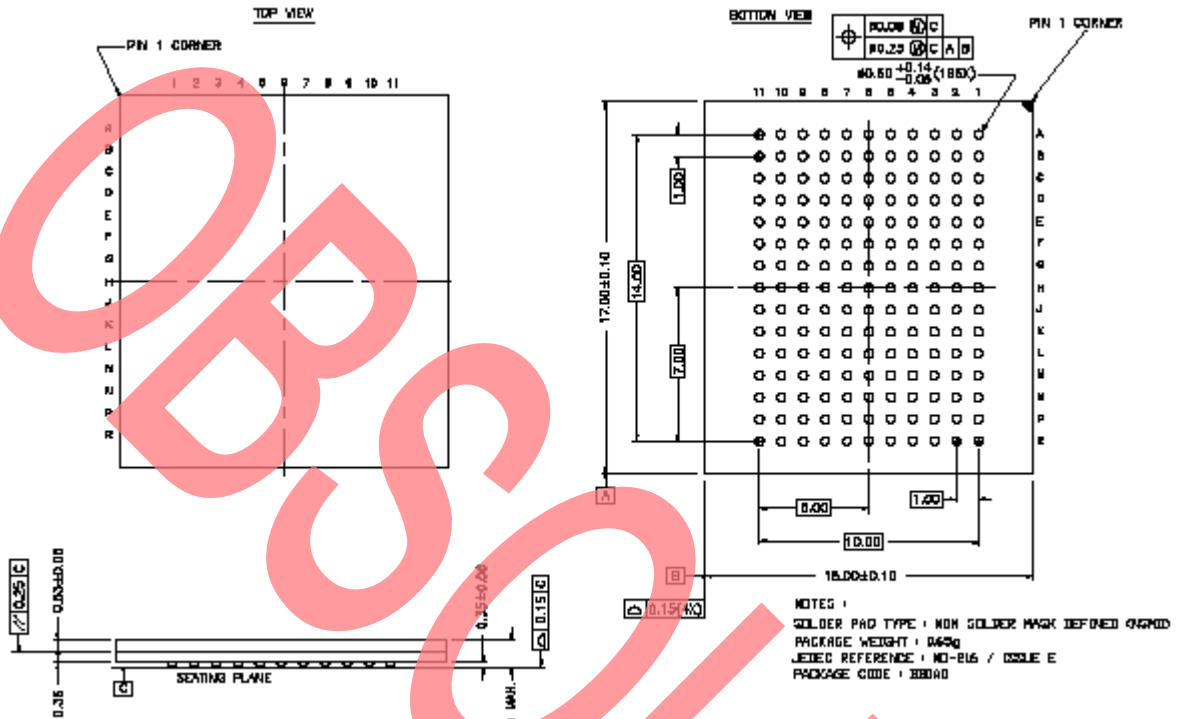

51-85195 \*B

## Acronyms

Table 4. Acronyms Used in this Document

Acronym	Description
DDR	double data rate
FBGA	fine-pitch ball grid array
HSTL	high-speed transceiver logic
JEDEC	joint electron device engineering council
JTAG	joint test action group
ODT	on-die termination
PLL	phase-locked loop
QDR	quad data rate
TAP	test access port
TCK	test clock
TDO	test data out
TDI	test data in
TMS	test mode select

## Document History Page

Document Title: CY7C1512V18/CY7C1514V18, 72-Mbit QDR® II SRAM Two-Word Burst Architecture				
Document Number: 38-05489				
Revision	ECN	Orig. Of Change	Submission Date	Description Of Change
**	201260	NJY	See ECN	New Datasheet
*A	257089	NJY	See ECN	Removed foot note 13 on page 12 Modified JTAG ID register definition table on page 21 Changed Max value of $t_{cyc}$ at 250 MHz from 5.25 ns to 6.3 ns and Max value of $t_{cyc}$ at 200 MHz from 6.3 ns to 7.9 ns. Changed Max value of $t_{KHCH}$ at 200 MHz from 2.3 ns to 2.2 ns and Max value of $t_{KHCH}$ at 167 MHz from 2.8 ns to 2.7 ns Included thermal values Modified capacitance values table: included capacitance values for x8, x18 and x36 options
*B	319496	SYT	See ECN	Removed CY7C1525V18 from the title Included 300 MHz Speed bin Added footnote #1 and accordingly edited the $V_{SS}/144M$ And $V_{SS}/288M$ on the Pin Definitions table. Added Industrial Temperature Grade Replaced TBDs for $I_{DD}$ and $I_{SB1}$ for 300 MHz, 250 MHz, 200 MHz and 167 MHz speed grades Changed the $C_{IN}$ from 5 pF to 5.5 pF and $C_O$ from 7 pF to 8 pF in the Capacitance Table Removed the capacitance value column for the x9 option from Capacitance Table Changed typo of bit # 47 to bit # 108 under the EXTEST OUTPUT BUS TRISTATE on Page 18 Added Pb-free product information Updated the Ordering Information by Shading and Unshading MPNs as per availability
*C	403231	NXR	See ECN	Converted from Preliminary to Final Added CY7C1525V18 to the title Removed 300 MHz Speed bin Changed address of Cypress Semiconductor Corporation on Page# 1 from "3901 North First Street" to "198 Champion Court" Changed C/C Pin Description in the features section and Pin Description Added power-up sequence details and waveforms Added foot notes # 14, 15, 16 on page# 19 Replaced Three-state with Tristate Changed the description of $I_x$ from Input Load Current to Input Leakage Current on page# 20, Modified the $I_{DD}$ and $I_{SB}$ current values Modified test condition in Footnote # 21 on page# 20 from $V_{DDQ} < V_{DD}$ to $V_{DDQ} \leq V_{DD}$ Replaced Package Name column with Package Diagram in the Ordering Information table, Updated the Ordering Information.
*D	467290	NXR	See ECN	Modified the ZQ Definition from Alternately, this pin can be connected directly to $V_{DD}$ to Alternately, this pin can be connected directly to $V_{DDQ}$ Included Maximum Ratings for Supply Voltage on $V_{DDQ}$ Relative to GND Changed the Maximum Ratings for DC Input Voltage from $V_{DDQ}$ to $V_{DD}$ Changed $t_{CYC}$ from 100 ns to 50 ns, changed $t_{TF}$ from 10 MHz to 20 MHz, changed $t_{TH}$ and $t_{TL}$ from 40 ns to 20 ns, changed $t_{TMSS}$ , $t_{TDIS}$ , $t_{CS}$ , $t_{TMSH}$ , $t_{TDIH}$ , $t_{CH}$ from 10 ns to 5 ns and changed $t_{TDOV}$ from 20 ns to 10 ns in TAP AC Switching Characteristics table. Modified power-up waveform Added additional notes in the AC parameter section Changed the $t_{SC}$ and $t_{HC}$ value from 0.5 ns to 0.35 ns for 250 MHz, from 0.6 ns to 0.4 ns for 200 MHz, and from 0.7 ns to 0.5 ns for 167 MHz. Modified AC Switching Waveform, Corrected the typo In the AC Switching Characteristics Table, Updated the Ordering Information Table

## Document History Page

Document Title: CY7C1512V18/CY7C1514V18, 72-Mbit QDR® II SRAM Two-Word Burst Architecture				
Document Number: 38-05489				
*E	2511080	VKN/AESA	See ECN	Updated Logic Block diagram, Updated power-up sequence waveform and it's description, Updated I <sub>DD</sub> /I <sub>SB</sub> specs, Added footnote #19 related to I <sub>DD</sub> , Changed DLL minimum operating frequency from 80MHz to 120MHz, Changed t <sub>CYC</sub> max spec to 8.4ns for all speed bins, Modified footnotes 21 and 28, Changed Θ <sub>JA</sub> spec from 16.2 to 16.3, Changed Θ <sub>JC</sub> spec from 2.3 to 2.1
*F	2549270	PYRS	08/06/08	Publish in External Web
*G	2756998	VKN	08/28/09	Removed x8 and x9 part number details Included Soft Error Immunity Data Modified Ordering Information table by including parts that are available and modified the disclaimer for the Ordering information. Updated Package Diagram.
*H	2998771	NJY	08/02/10	Template update.
*I	3056490	HMLA	10/12/10	Inactive parts; obsolete datasheet

## Sales, Solutions, and Legal Information

### Worldwide Sales and Design Support

Cypress maintains a worldwide network of offices, solution centers, manufacturer's representatives, and distributors. To find the office closest to you, visit us at [Cypress Locations](#).

### Products

Automotive	<a href="http://cypress.com/go/automotive">cypress.com/go/automotive</a>
Clocks & Buffers	<a href="http://cypress.com/go/clocks">cypress.com/go/clocks</a>
Interface	<a href="http://cypress.com/go/interface">cypress.com/go/interface</a>
Lighting & Power Control	<a href="http://cypress.com/go/powerpsoc">cypress.com/go/powerpsoc</a> <a href="http://cypress.com/go/plc">cypress.com/go/plc</a>
Memory	<a href="http://cypress.com/go/memory">cypress.com/go/memory</a>
Optical & Image Sensing	<a href="http://cypress.com/go/image">cypress.com/go/image</a>
PSoC	<a href="http://cypress.com/go/psoc">cypress.com/go/psoc</a>
Touch Sensing	<a href="http://cypress.com/go/touch">cypress.com/go/touch</a>
USB Controllers	<a href="http://cypress.com/go/USB">cypress.com/go/USB</a>
Wireless/RF	<a href="http://cypress.com/go/wireless">cypress.com/go/wireless</a>

### PSoC Solutions

[psoc.cypress.com/solutions](http://psoc.cypress.com/solutions)  
PSoC 1 | PSoC 3 | PSoC 5

© Cypress Semiconductor Corporation, 2004-2010. The information contained herein is subject to change without notice. Cypress Semiconductor Corporation assumes no responsibility for the use of any circuitry other than circuitry embodied in a Cypress product. Nor does it convey or imply any license under patent or other rights. Cypress products are not warranted nor intended to be used for medical, life support, life saving, critical control or safety applications, unless pursuant to an express written agreement with Cypress. Furthermore, Cypress does not authorize its products for use as critical components in life-support systems where a malfunction or failure may reasonably be expected to result in significant injury to the user. The inclusion of Cypress products in life-support systems application implies that the manufacturer assumes all risk of such use and in doing so indemnifies Cypress against all charges.

Any Source Code (software and/or firmware) is owned by Cypress Semiconductor Corporation (Cypress) and is protected by and subject to worldwide patent protection (United States and foreign), United States copyright laws and international treaty provisions. Cypress hereby grants to licensee a personal, non-exclusive, non-transferable license to copy, use, modify, create derivative works of, and compile the Cypress Source Code and derivative works for the sole purpose of creating custom software and/or firmware in support of licensee product to be used only in conjunction with a Cypress integrated circuit as specified in the applicable agreement. Any reproduction, modification, translation, compilation, or representation of this Source Code except as specified above is prohibited without the express written permission of Cypress.

Disclaimer: CYPRESS MAKES NO WARRANTY OF ANY KIND, EXPRESS OR IMPLIED, WITH REGARD TO THIS MATERIAL, INCLUDING, BUT NOT LIMITED TO, THE IMPLIED WARRANTIES OF MERCHANTABILITY AND FITNESS FOR A PARTICULAR PURPOSE. Cypress reserves the right to make changes without further notice to the materials described herein. Cypress does not assume any liability arising out of the application or use of any product or circuit described herein. Cypress does not authorize its products for use as critical components in life-support systems where a malfunction or failure may reasonably be expected to result in significant injury to the user. The inclusion of Cypress' product in a life-support systems application implies that the manufacturer assumes all risk of such use and in doing so indemnifies Cypress against all charges.

Use may be limited by and subject to the applicable Cypress software license agreement.