



HARRIS

MUR1540 **RUR1540**
MUR1550 **RUR1550**
MUR1560 **RUR1560**

56E D ■ 4302271 0042383 STT ■ HAS

15A Ultrafast Diode

With Soft Recovery Characteristic

May 1991

HARRIS SEMICONDUCTOR

Features

- Ultrafast with Soft Recovery Characteristic ($t_{rr} < 55\text{ns}$)
- +175°C Rated Junction Temperature
- Reverse Voltage Up to 600V
- Avalanche Energy Rated

Applications

- Switching Power Supply
- Power Switching Circuits
- General Purpose

Description

MUR1540, MUR1550, MUR1560 and RUR1540, RUR1550, RUR1560 are ultrafast dual diodes ($t_{rr} < 55\text{ns}$) with soft recovery characteristics ($t_a/t_b \approx 1$). They have a low forward voltage drop and are of planar, silicon nitride passivated, ion-implanted, epitaxial construction.

These devices are intended for use as energy steering/clamping diodes and rectifiers in a variety of switching power supplies and other power switching applications. Their low stored charge and ultrafast recovery with soft recovery characteristics minimizes ringing and electrical noise in many power switching circuits thus reducing power loss in the switching transistor.

All are supplied in TO-220AC packages.

Package

F03-17

TO-220AC
TOP VIEW

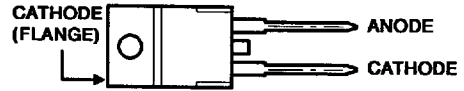

Symbol



Absolute Maximum Ratings ($T_C = +25^\circ\text{C}$)

	MUR1540 RUR1540	MUR1550 RUR1550	MUR1560 RUR1560
Peak Repetitive Reverse Voltage..... V_{RRM}	400V	500V	600V
Working Peak Reverse Voltage..... V_{RWM}	400V	500V	600V
DC Blocking Voltage..... V_R	400V	500V	600V
Average Rectified Forward Current..... $I_{F(AV)}$ (Total device forward current at rated V_F and $T_C = 150^\circ\text{C}$)	15A	15A	15A
Peak Forward Repetitive Current..... I_{FRM} (Rated V_F , square wave 20kHz)	30A	30A	30A
Nonrepetitive Peak Surge Current..... I_{FSM} (Surge applied at rated load condition halfwave 1 phase 60Hz)	200A	200A	200A
Operating and Storage Temperature..... T_s, T_j	-55°C to +175°C	-55°C to +175°C	-55°C to +175°C

Electrical Characteristics ($T_C = +25^\circ\text{C}$) Unless Otherwise Specified.

T-03-17

SYMBOL	TEST CONDITION	LIMITS									UNITS
		MUR1540, RUR1540			MUR1550, RUR1550			MUR1560, RUR1560			
		MIN	TYP	MAX	MIN	TYP	MAX	MIN	TYP	MAX	
V_F	$I_F = 15\text{A}$ $T_C = +150^\circ\text{C}$	-	-	1.12	-	-	1.20	-	-	1.20	V
	$I_F = 15\text{A}$ $T_C = +25^\circ\text{C}$	-	-	1.25	-	-	1.50	-	-	1.50	V
$I_R @$ $T_C = +150^\circ\text{C}$	$V_R = 400\text{V}$	-	-	500	-	-	-	-	-	-	μA
	$V_R = 500\text{V}$	-	-	-	-	-	500	-	-	-	μA
	$V_R = 600\text{V}$	-	-	-	-	-	-	-	-	500	μA
$I_R @$ $T_C = +25^\circ\text{C}$	$V_R = 400\text{V}$	-	-	10	-	-	-	-	-	-	μA
	$V_R = 500\text{V}$	-	-	-	-	-	10	-	-	-	μA
	$V_R = 600\text{V}$	-	-	-	-	-	-	-	-	10	μA
t_{rr}	$I_F = 1\text{A}$	-	-	55	-	-	55	-	-	55	ns
	$I_F = 15\text{A}$	-	-	60	-	-	60	-	-	60	ns
t_a	$I_F = 1\text{A}$	-	20	-	-	20	-	-	20	-	ns
	$I_F = 15\text{A}$	-	30	-	-	30	-	-	30	-	ns
t_b	$I_F = 1\text{A}$	-	15	-	-	15	-	-	15	-	ns
	$I_F = 15\text{A}$	-	17	-	-	17	-	-	20	-	ns
$R_{\theta jc}$		-	-	1.5	-	-	1.5	-	-	1.5	$^\circ\text{C/W}$
W_{avl}	see Fig. 7&8	-	-	20	-	-	20	-	-	20	mJ

Definitions

V_F = Instantaneous forward voltage ($p_w = 300\mu\text{s}$, $D = 2\%$).

I_R = Instantaneous reverse current ($p_w = 300\mu\text{s}$, $D = 2\%$).

t_{rr} = Reverse recovery time at $dI_F/dt = 100\text{A}/\mu\text{s}$ (See Figure 2), summation of $t_a + t_b$.

t_a = Time to reach peak reverse current at $dI_F/dt = 100\text{A}/\mu\text{s}$ (See Figure 2).

t_b = Time from peak I_{RM} to projected zero crossing of I_{RM} based on a straight line from peak I_{RM} through 25% of I_{RM} . (See Figure 2)

$R_{\theta jc}$ = Thermal resistance junction to case.

W_{avl} = Controlled avalanche energy (See Figures 7 & 8).

p_w = pulse width.

D = duty cycle.

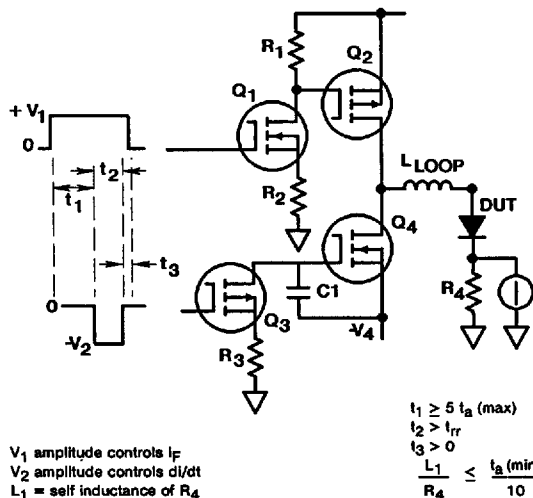

FIGURE 1. t_{rr} TEST CIRCUIT

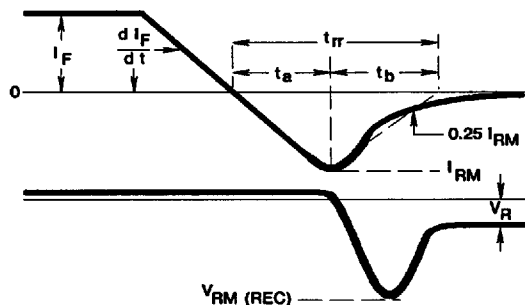

FIGURE 2. DEFINITIONS OF t_{rr} , t_a AND t_b

ULTRA-FAST RECTIFIERS

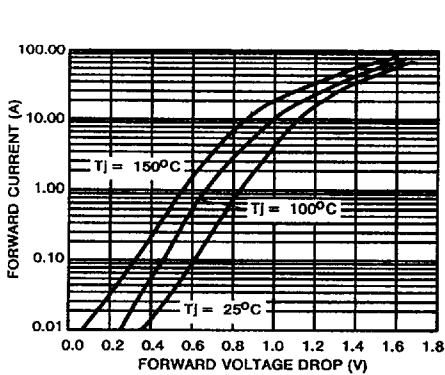

FIGURE 3. FORWARD VOLTAGE vs FORWARD CURRENT CHARACTERISTIC

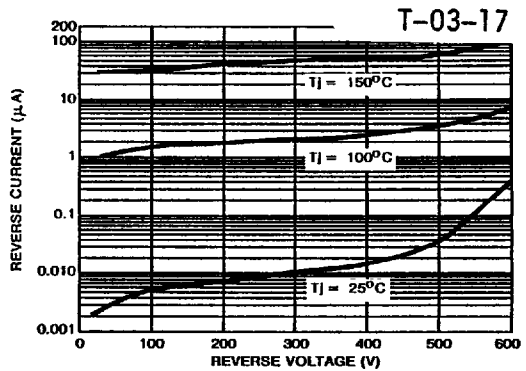

FIGURE 4. REVERSE VOLTAGE vs REVERSE CURRENT CHARACTERISTIC

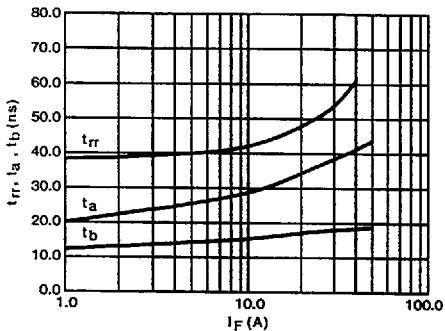

FIGURE 5. TYPICAL t_{rr} , t_a , t_b vs FORWARD CURRENT

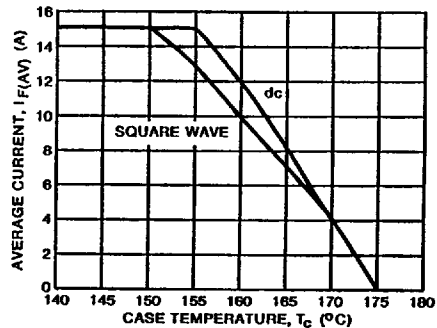

FIGURE 6. TYPICAL CURRENT DERATING CURVE w.r.t. CASE TEMPERATURE

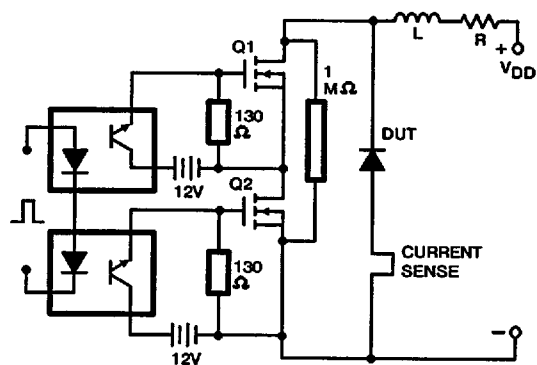

FIGURE 7. AVALANCHE ENERGY TEST CIRCUIT

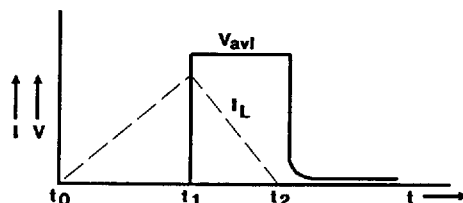

FIGURE 8. CURRENT VOLTAGE WAVEFORM

$$I_{L\text{peak}} = 1A, L = 40mH, R < 0.1\Omega, W_{avl} = (1/2) L I_L^2 [V_{avl} / (V_{avl} - V_{dd})]$$