



# TAOGLAS®



# Datasheet

## Wi-Fi High Band Patch

**Part No:**

WLP.4958.12.4.A.02

**Description:**

12mm\*12mm\*4mm 4.9~5.8GHz Pin mount Ceramic Patch

**Features:**

For Upper band Wi-Fi 4.9-5.8GHz

Ceramic Patch with Pin

High Gain - up to 7dBi

TESA adhesive for ease of mounting

Dimensions: 12 x 12 x 4mm

RoHS & REACH Compliant

1. Introduction	3
2. Specifications	4
3. Antenna Characteristics	5
4. Radiation Patterns	7
5. Mechanical Drawing	9
6. Antenna Integration Guide	10
7. Mechanical Drawing – Evaluation Board	15
8. Packaging	16
Changelog	17

Taoglas makes no warranties based on the accuracy or completeness of the contents of this document and reserves the right to make changes to specifications and product descriptions at any time without notice. Taoglas reserves all rights to this document and the information contained herein. Reproduction, use or disclosure to third parties without express permission is strictly prohibited.



# 1. Introduction



This 12mm\*12mm\*4mm 6dBi high gain 4.9~5.8GHz patch pin fed antenna is ideally suited for high performance industrial and consumer applications in Wi-fi, ISM, Public Safety, and Zigbee bands. It can also be placed anywhere on the device ground-plane, unlike most chip or loop antennas which need to be edge mounted. The antenna can be matched by a PI matching circuit, or by creating a custom tuned part for a specific layout configuration on a board.

Many module manufacturers specify peak gain limits for any antennas that are to be connected to that module. Those peak gain limits are based on free-space conditions. In practice, the peak gain of an antenna tested in free-space can degrade by at least 1 or 2dBi when put inside a device. So ideally you should go for a slightly higher peak gain antenna than mentioned on the module specification to compensate for this effect, giving you better performance.

Upon testing of any of our antennas with your device and a selection of appropriate layout, integration technique, or cable, Taoglas can make sure any of our antennas' peak gain will be below the peak gain limits. Taoglas can then issue a specification and/or report for the selected antenna in your device that will clearly show it complying with the peak gain limits, so you can be assured you are meeting regulatory requirements for that module.

For example, a module manufacturer may state that the antenna must have less than 2dBi peak gain, but you don't need to select an embedded antenna that has a peak gain of less than 2dBi in free-space. This will give you a less optimized solution. It is better to go for a slightly higher free-space peak gain of 3dBi or more if available. Once that antenna gets integrated into your device, performance will degrade below this 2dBi peak gain due to the effects of GND plane, surrounding components, and device housing. If you want to be absolutely sure, contact Taoglas and we will test. Choosing a Taoglas antenna with a higher peak gain than what is specified by the module manufacturer and enlisting our help will ensure you are getting the best performance possible without exceeding the peak gain limits.

The patch can be specifically tuned for customer applications/devices subject to NRE and MOQ, for further information please contact your regional Taoglas customer support team.

## 2. Specifications

Electrical	
Frequency (MHz)	4900 to 5825
Peak Gain (dBi)	
On 70*70mm GND Plane	6
VSWR	
On 70*70mm GND Plane	1.5:1
Efficiency	
On 70*70mm GND Plane	69%
Impedance	50Ω
Polarization	Linear
Radiation Pattern	Omni-Directional
Mechanical	
Dimensions	12 x 12 x 4 mm
Material	Ceramic
Adhesive	TESA 4972
Environmental	
Operating Temperature	-40°C to 85°C
Storage Temperature	-40°C to 85°C
RoHS Compliant	Yes
REACH Compliant	Yes

### 3. Antenna Characteristics

#### 3.1 Return Loss

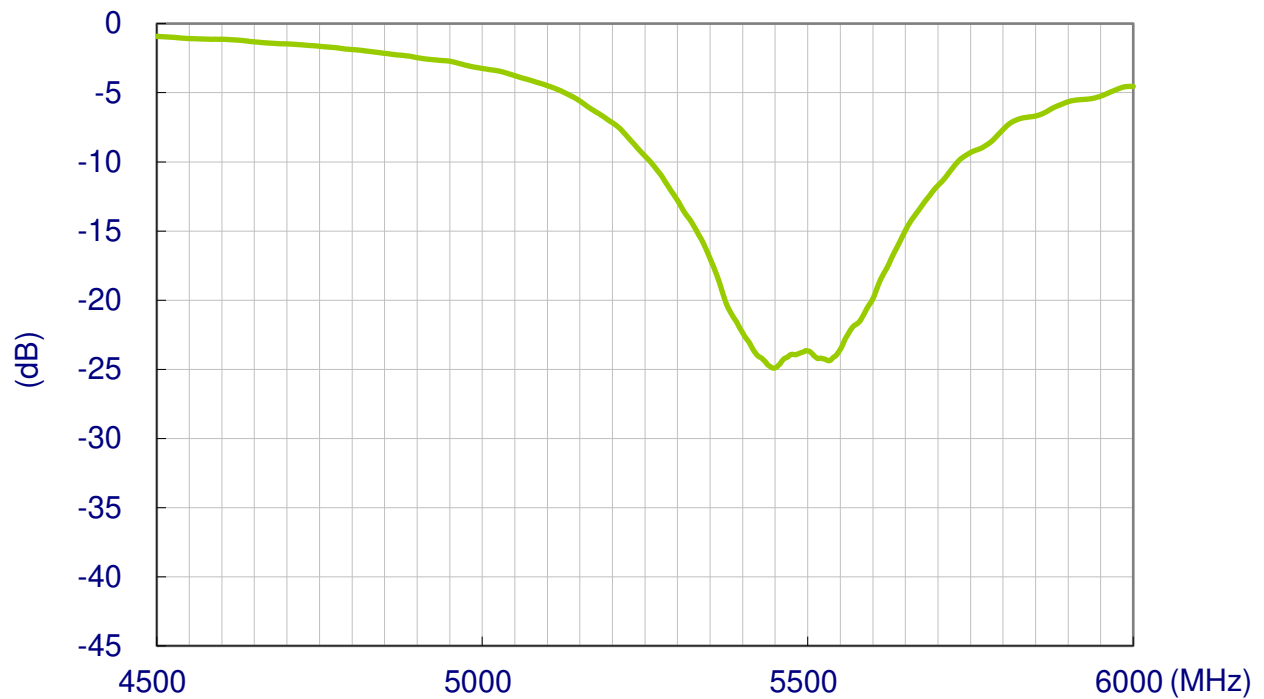

#### 3.2 Efficiency

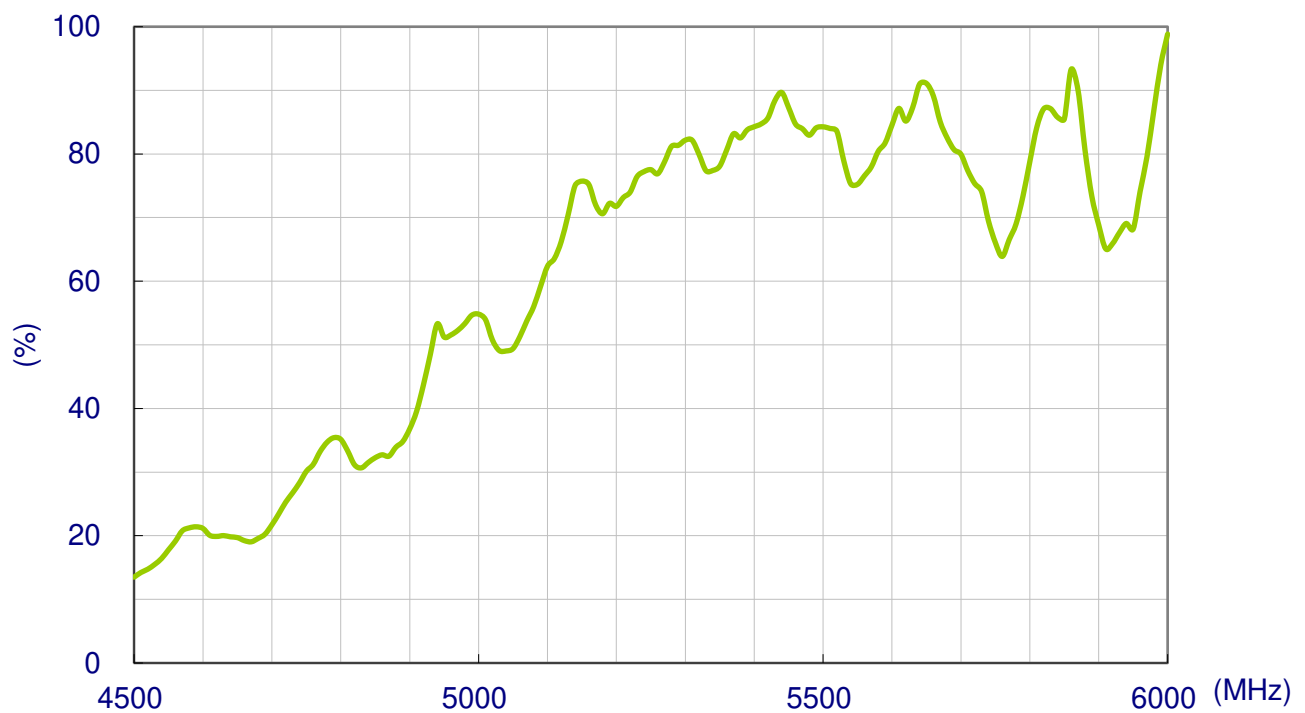

### 3.3 Average Gain

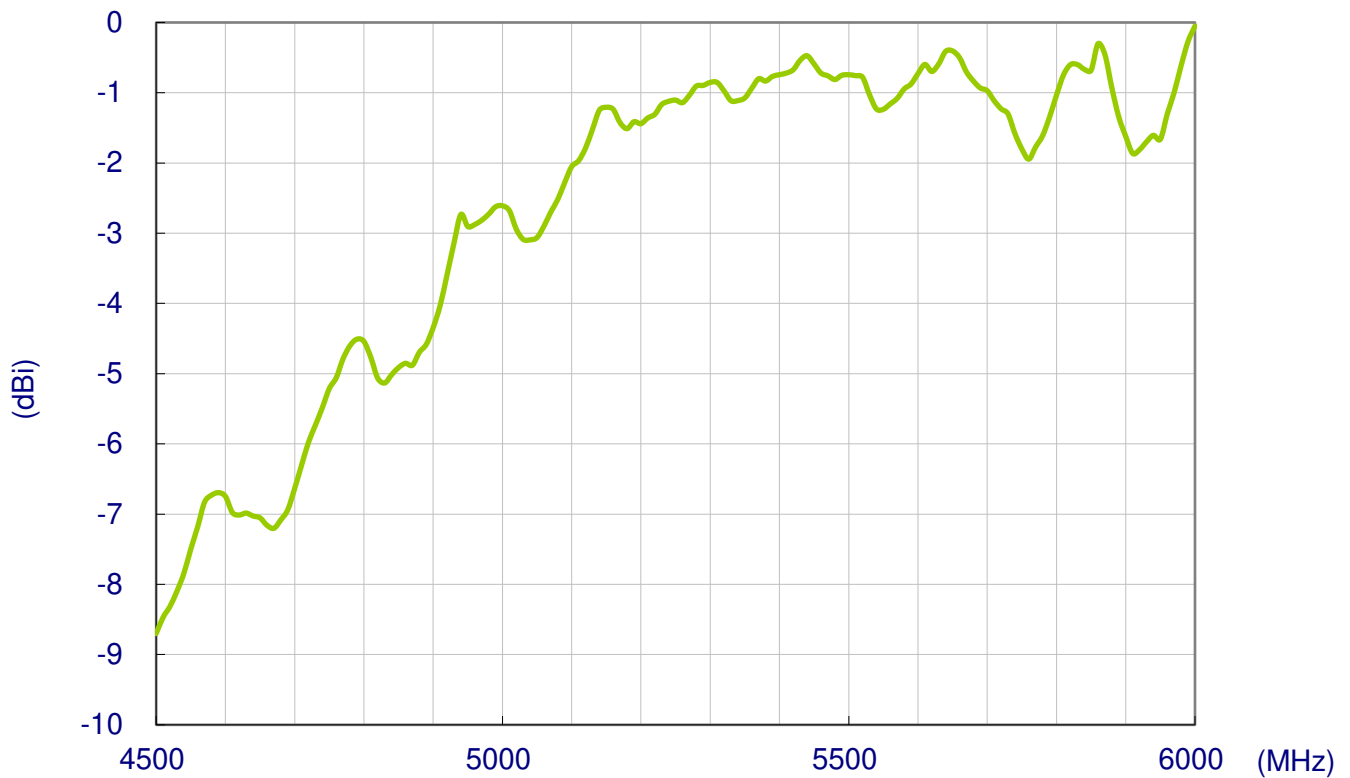

### 3.4 Peak Gain

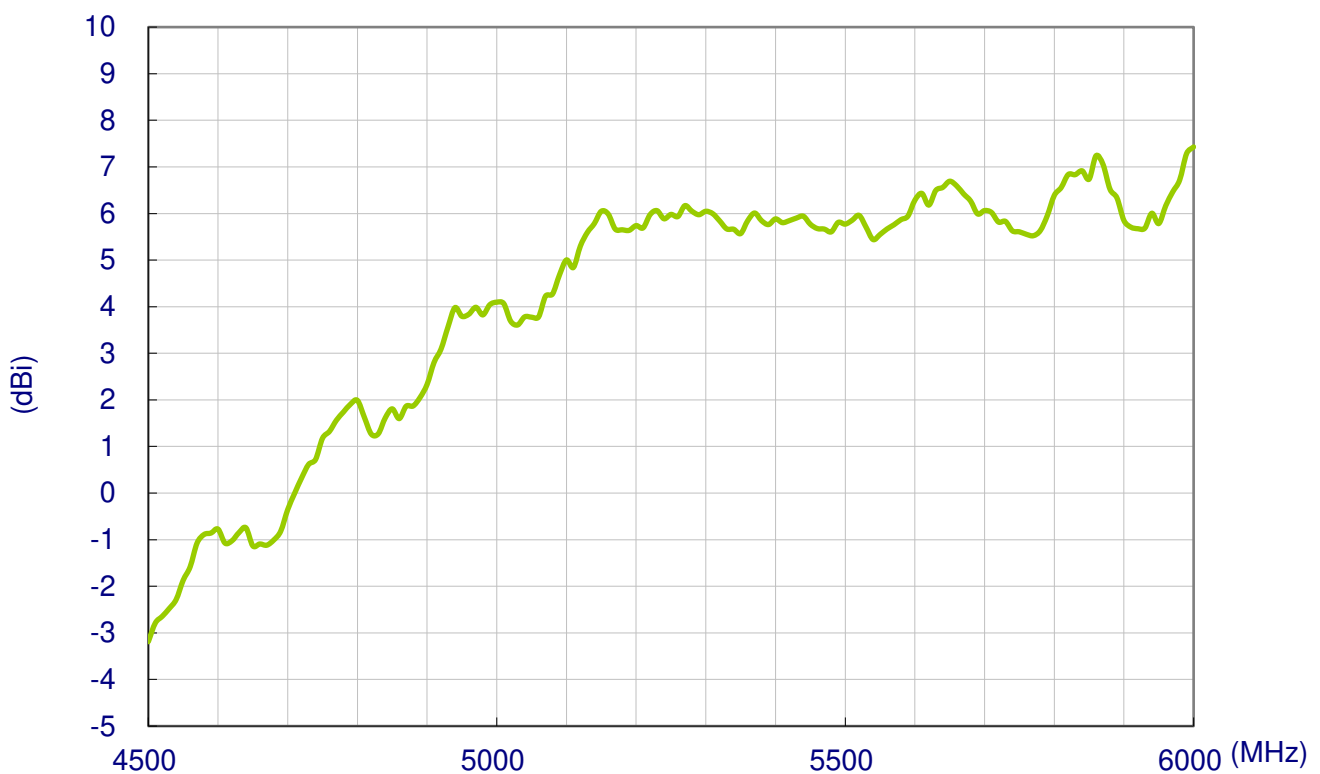

## 4. Radiation Patterns

### 4.1 Test Setup



On 70\*70mm Ground Plane

4.2 2D Radiation Patterns

XY Plane

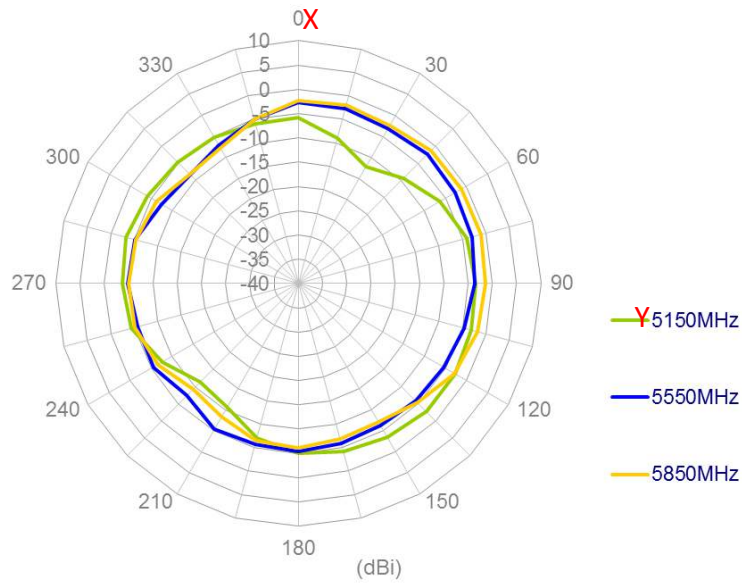

XZ Plane

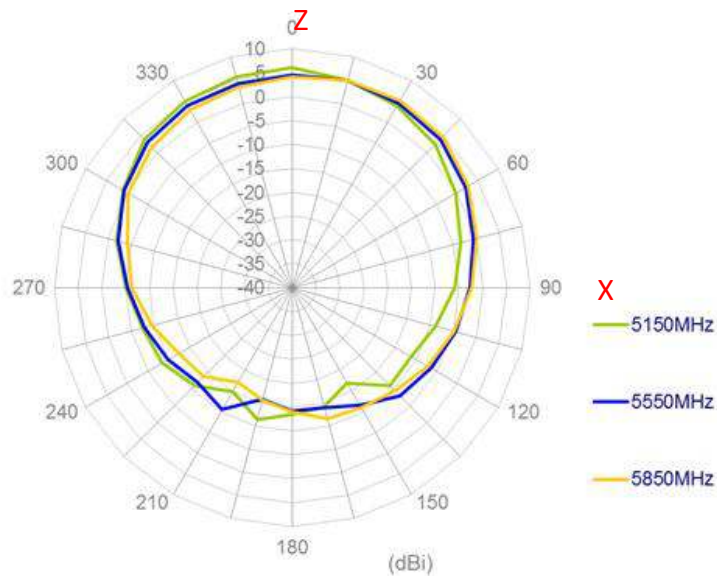

YZ Plane

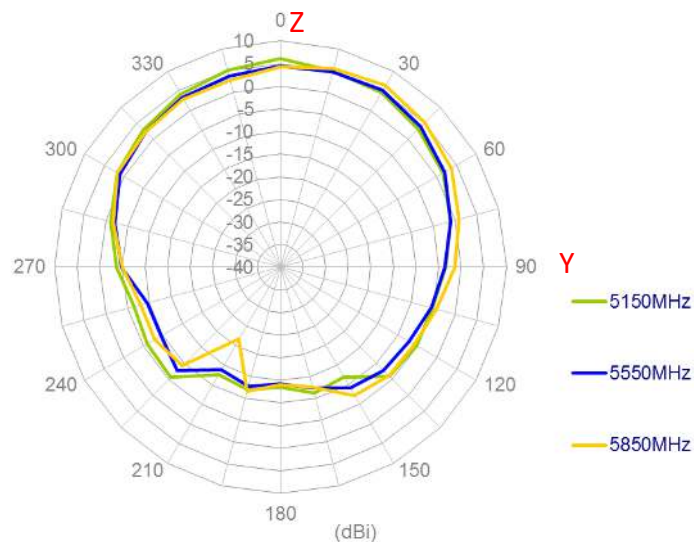



# 5. Mechanical Drawing (Units: mm)

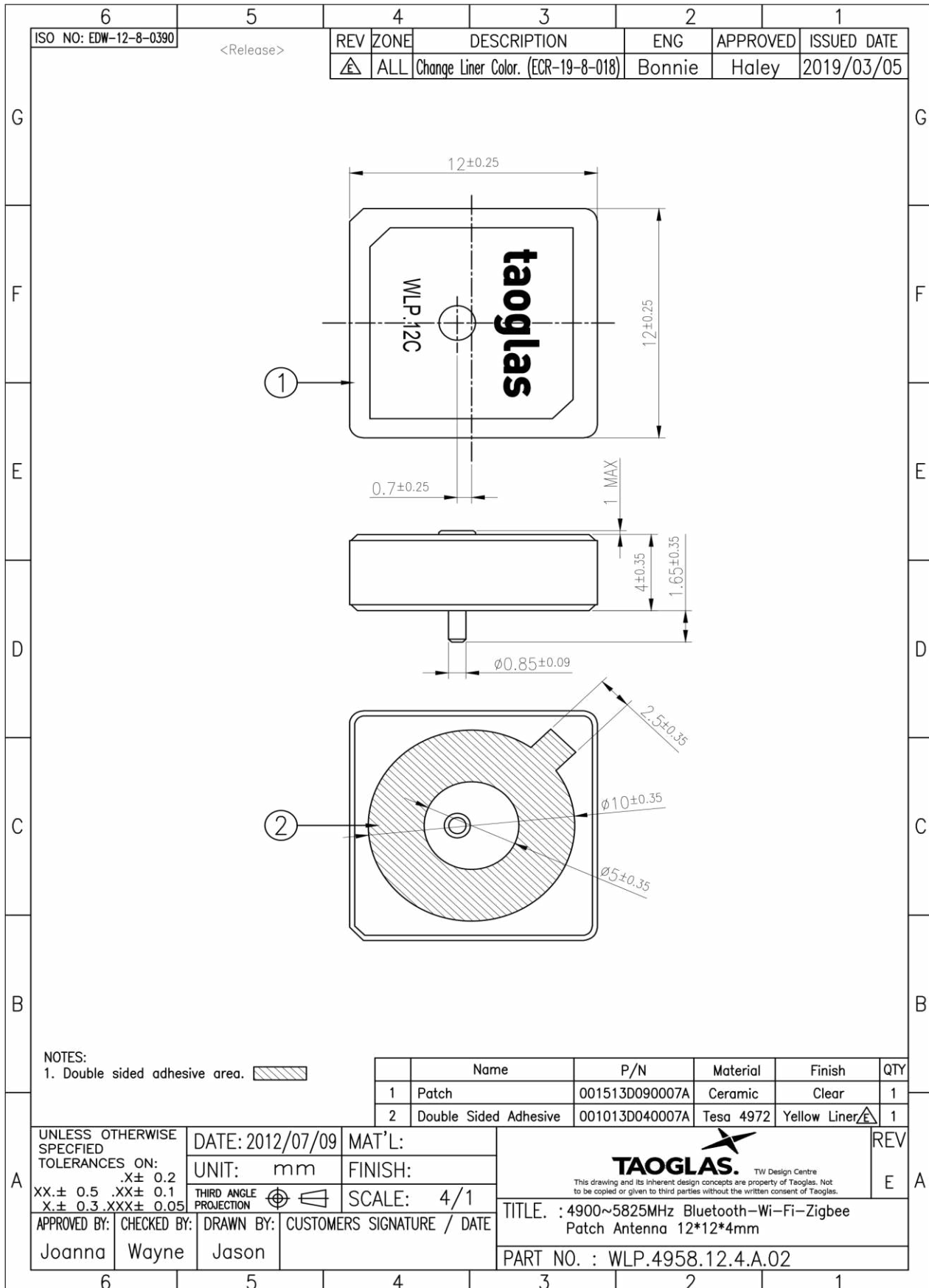

## 6. Antenna Integration Guide



## 6.1 Schematic Symbol and Pin Definition

The circuit symbol for the antenna is shown below. The antenna has 1 pin as indicated below.

Pin	Description
1	RF Feed

SGGP.25 2.A.02  
ANTI

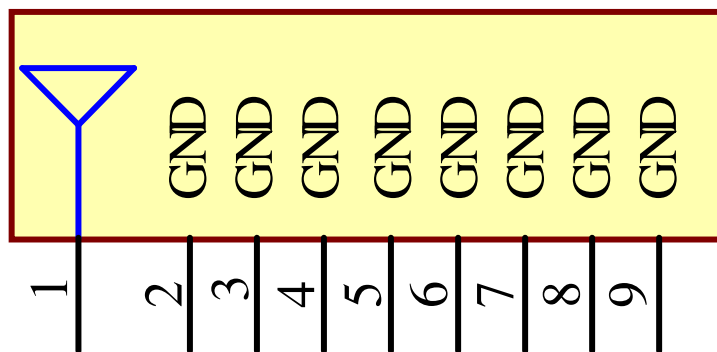

## 6.2 Antenna Integration

The antenna should be placed at the center of the ground plane with a length and width of 70mm. Maintaining a square symmetric ground plane shape and symmetric environment around the antenna is critical to maintaining the excellent axial ratio and phase center performance shown in this datasheet.



Top Side w/ Solder Mask



Top Side w/o Solder Mask

## 6.3 PCB Layout

The footprint and clearance on the PCB must comply with the antenna specification. The PCB layout shown in the diagram below demonstrates the antenna footprint.

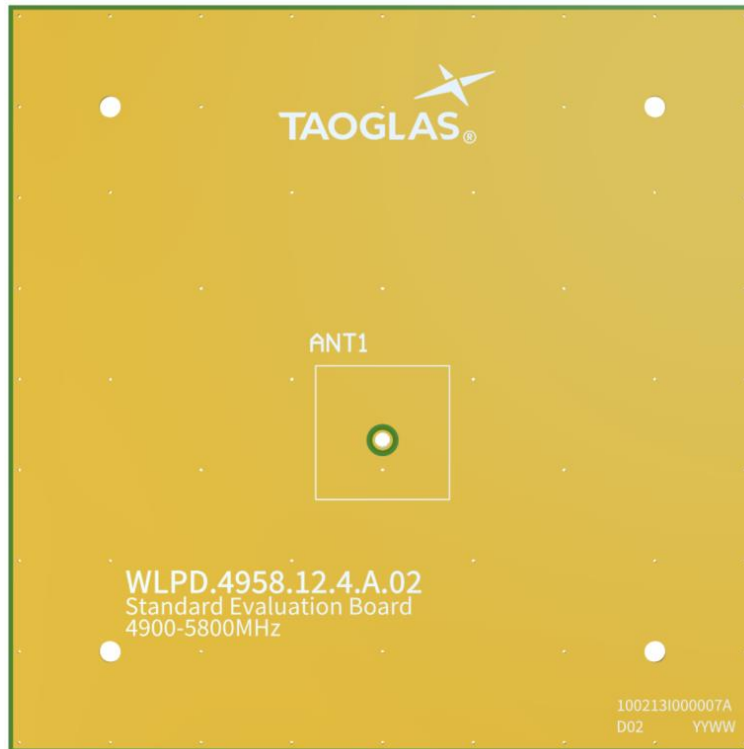

Topside

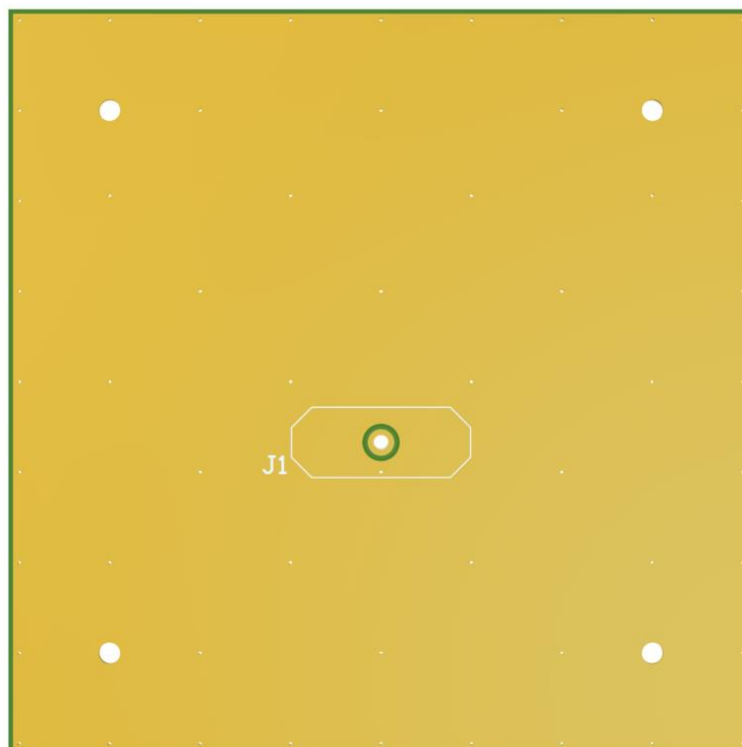

Bottom Side

## 6.4 Evaluation Board

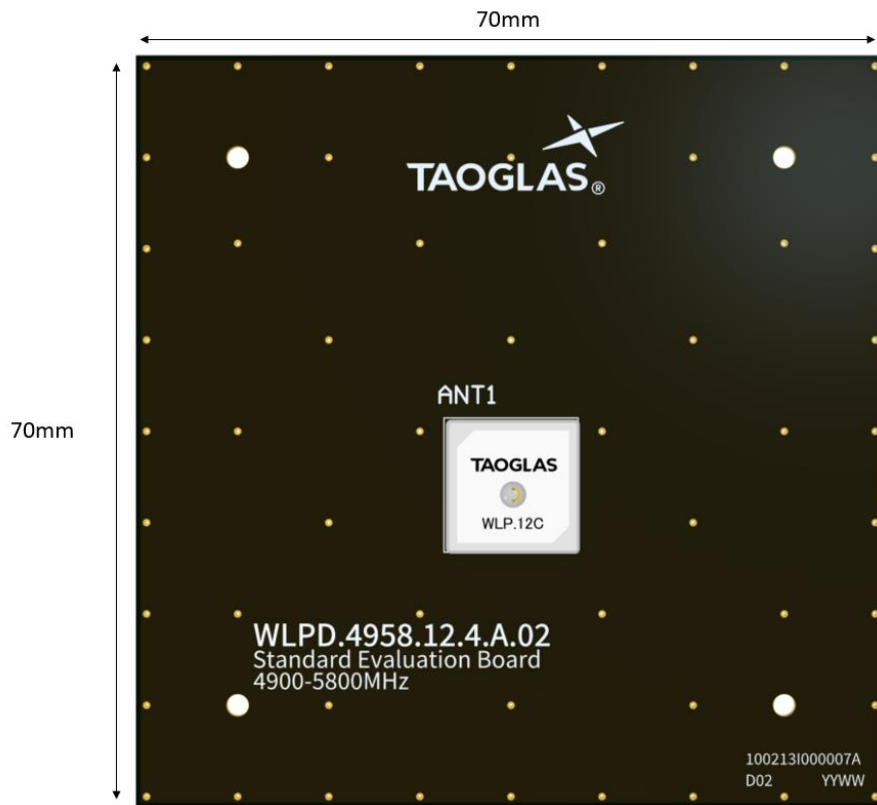

Topside

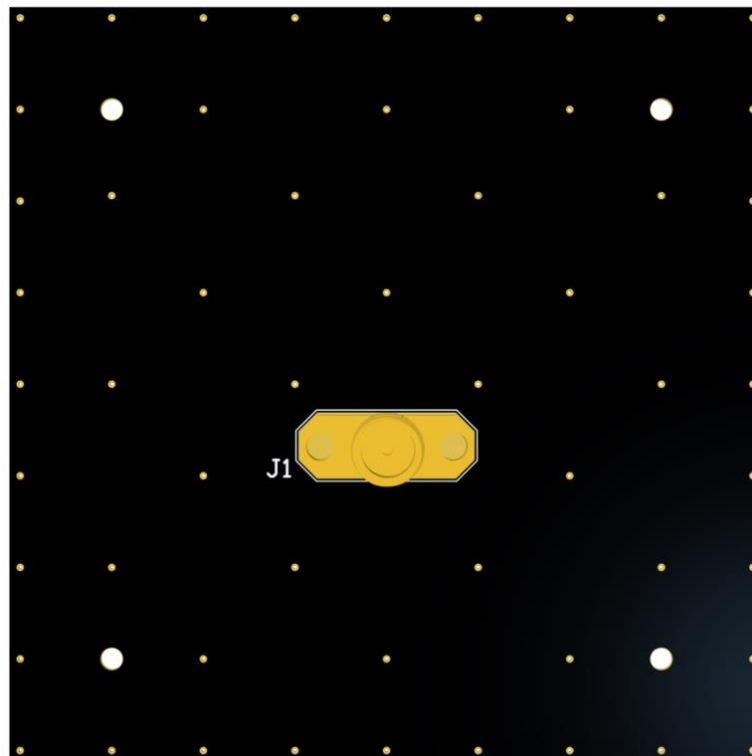

Bottom Side

# 7. Mechanical Drawing – Evaluation Board

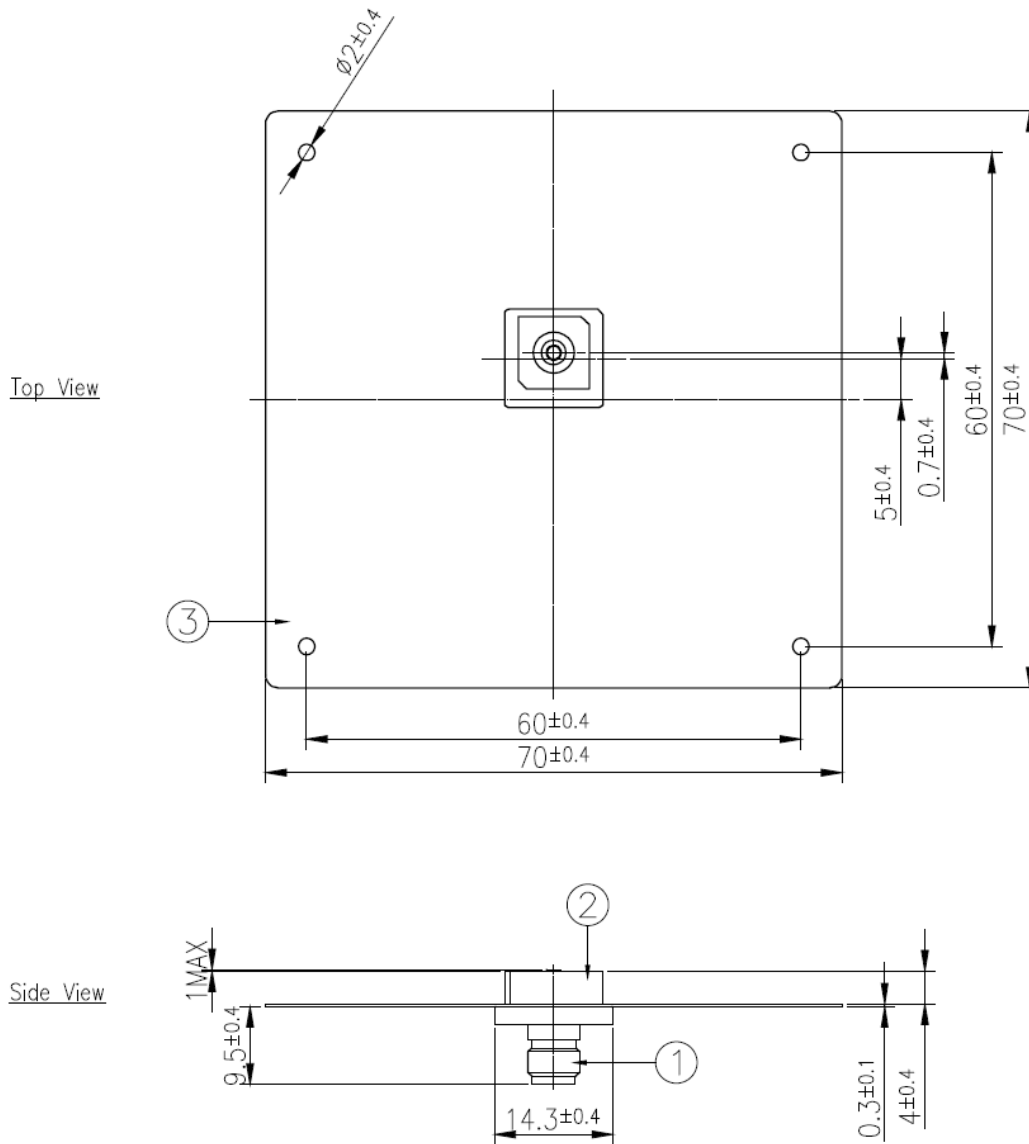

	Name	P/N	Material	Finish	QTY
1	PCB SMA(F) ST	001513C210007A	Brass	Au Plated	1
2	WLP.4958 Patch (12x12x4mm)	001513C220007A	Ceramic	Clear	1
3	WLPD.4958 PCB (70x70x0.3mm)	100213I000007A	FR4 0.3t	N/A	1

## 8. Packaging

25pcs WLP.4958.12.4.A.02 per tray  
Weight – 100g

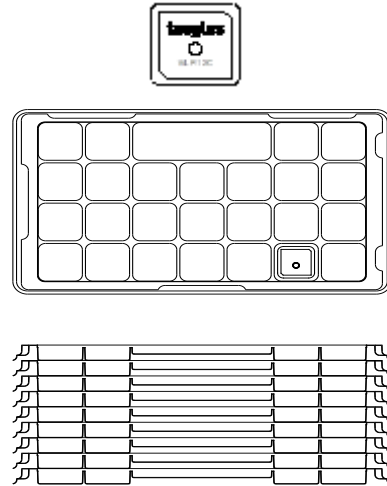

400pcs WLP.4958.12.4.A.02 per carton  
Dimensions - 263\*154\*96mm  
Weight – 2Kg

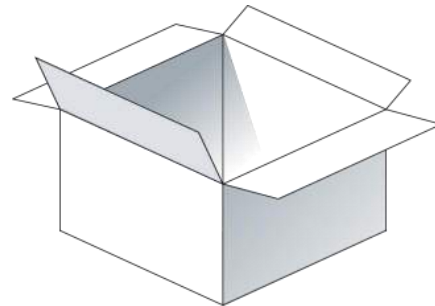

1600pcs WLP.4958.12.4.A.02 per carton  
Dimensions - 327\*280\*218mm  
Weight – 8.2Kg

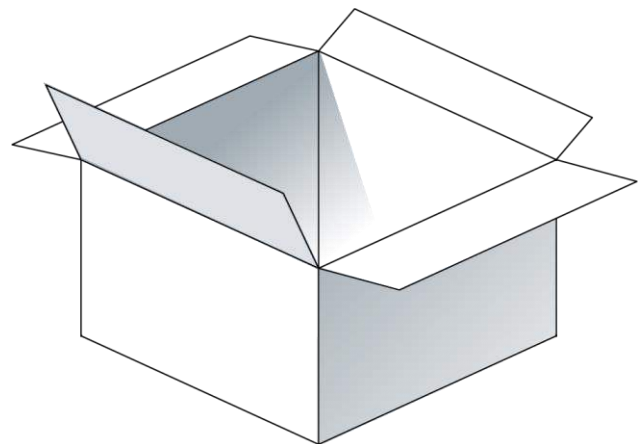



Changelog for the datasheet

**SPE-13-8-023 – WLP.4958.12.4.A.02**

<b>Revision: E (Current Version)</b>	
Date:	2023-03-16
Changes:	Antenna Integration Guide
Changes Made by:	Cesar Sousa

**Previous Revisions**

<b>Revision: D</b>	
Date:	2021-07-20
Changes:	Updated Format
Changes Made by:	Jack Conroy

<b>Revision: C</b>	
Date:	2017-03-16
Changes:	Updated to Linear
Changes Made by:	Peter Monahan

<b>Revision: B</b>	
Date:	2017-03-16
Changes:	Updated EDW
Changes Made by:	Jack Conroy

<b>Revision: A (Original First Release)</b>	
Date:	2013-02-22
Notes:	
Author:	Technical Writer



**TAOGLAS**®

[www.taoglas.com](http://www.taoglas.com)

