

4

3

2

1

LENGTH TABLE	
PART NUMBER	LENGTH (METERS)
ATHD06-1-12S-12G-M1	1 (3.28FT)
ATHD06-1-12S-12G-M2	2 (6.56FT)
ATHD06-1-12S-12G-M4	4 (13.12FT)
ATHD06-1-12S-12G-M5	5 (16.40FT)
ATHD06-1-12S-12G-M10	10 (32.80FT)

REVISIONS						
REV	ZONE	ECO	DESCRIPTION	DATE	BY	APPR
A1	-	-	RELEASED	3/31/2022	RO	WS

PLEASE CONTACT CSR FOR ADDITIONAL AVAILABLE OPTIONS

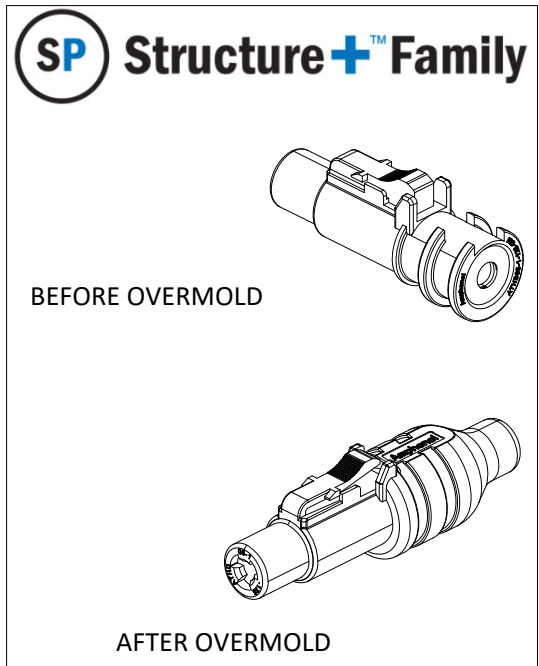
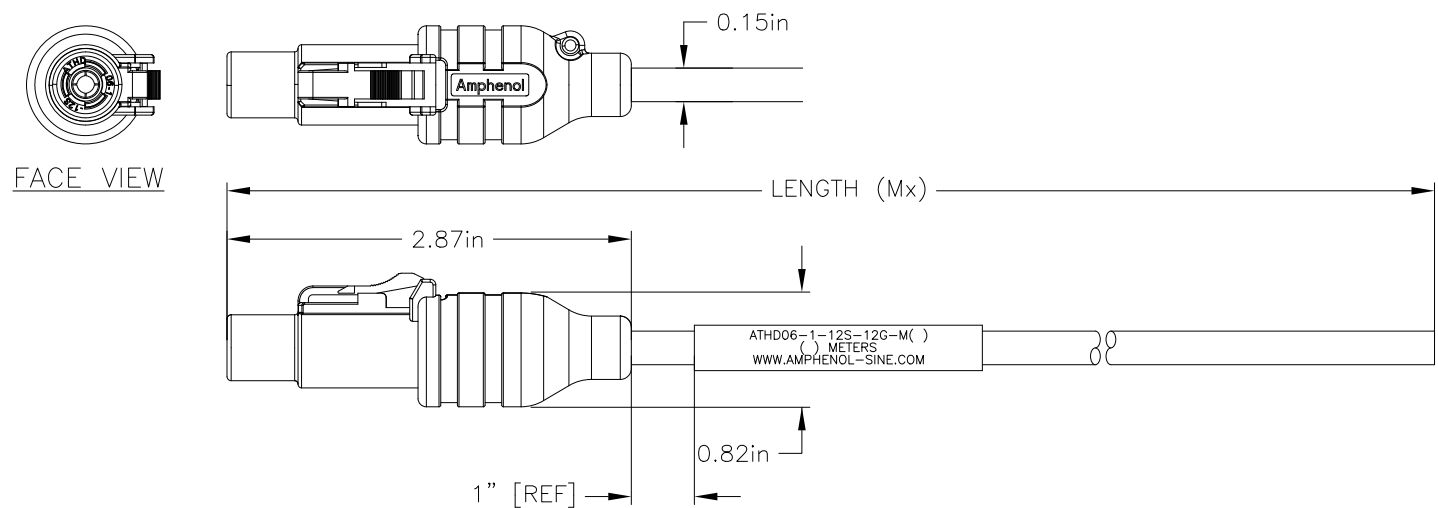

NOTES: UNLESS OTHERWISE SPECIFIED

- MATERIAL:
HOUSING: PA66
SEAL: SILICONE RUBBER
- MODIFICATIONS: OVERMOLDED (PA)
- CONNECTOR SPECIFICATIONS:
3.1 CURRENT RATING: 30AMPS
3.2 CABLE ASSEMBLY OPERATING TEMPERATURE: -40 TO +100C
3.3 CONTACT: COPPER ALLOY, NICKEL PLATED
3.4 DIELECTRIC WITHSTANDING VOLTAGE: LESS THAN 2 MILLIAMPS CURRENT LEAKAGE @ 1500 VOLTS AC.
3.5 INSULATION RESISTANCE: 1000 MEGAOHMS MIN @ 25C
3.6 MOISTURE RESISTANCE: IP68 MATED CONDITION (1M OF WATER FOR 24 HOURS).
3.7 MATING CYCLE DURABILITY: 100 CYCLES
3.8 RoHS COMPLIANT

- WIRE SPECIFICATIONS:
COMPONENTS: ONE 12AWG, PVC INSULATED CONDUCTOR
65x30 STRANDS BARE COPPER. UL1015
INSULATION: PVC, BLACK
600V AC/DC
- APPROVALS:
UL TYPE AWM, STYLE 1015.
CSA TYPE TEW.
OIL RESISTANT I
SUN RESISTANT I
FT1 FLAME RATING
ROHS COMPLIANT.
- MATING PART: ATHD04-1-12P RECEPTACLE.
MATING CABLE ASSEMBLY: ATHD04-1-12P-12G-Mx
- ALL DIMENSIONS ARE FOR REFERENCE USE ONLY.

QUANTITY	PART NUMBER	DESCRIPTION	ITEM
MATERIALS LIST			
UNLESS OTHERWISE SPECIFIED		SIGNATURES DATE	
1) All dimensions are in metric (mm).		DRAWN: RO	2/25/2022
2) Tolerances are as follows:		CHECKED: WS	3/22/2022
1 PL DEC ±0.30		ENGINEER: RO	
2 PL DEC ±0.15		APPROVAL: WS	3/25/2022
3 PL DEC ±0.08		CUSTOMER:	
3) Note reference =		THIS DRAWING IS SUPPLIED FOR INFORMATION ONLY. DESIGN FEATURES SPECIFICATIONS AND PERFORMANCE DATA SHOWN HEREON ARE THE PROPERTY OF THE AMPHENOL CORPORATION. NO RIGHTS OF REPRODUCTION ARE IMPLIED. ALL DIMENSIONS ARE SUBJECT TO NORMAL MANUFACTURING VARIATIONS.	
MATERIAL SPECIFICATIONS:		CUSTOMER:	
PROCESS SPECIFICATIONS:		1 POS PLUG SZ 12 MOLDED, SOCKET SIZE 12, 12AWG, SINGLE-ENDED WIRED ASSY, AMPHENOL ATHD CONNECTOR ATHD06-1-12S, X METERS	
NEXT ASSY:		SCALE: NONE	
		SIZE: C C- DWG NO: ATHD06-1-12S-12G-Mx REVISION: A1	
		SHEET 1 OF 1	

4

3

2

1