

# Absolute Pressure Sensor

KP126N6165

Data Sheet

Rev 1.02

Sense & Control



Never stop thinking

**Edition 2007-11-23**

**Published by  
Infineon Technologies AG  
81726 München, Germany  
© 2007 Infineon Technologies AG  
All Rights Reserved.**

#### **Legal Disclaimer**

The information given in this document shall in no event be regarded as a guarantee of conditions or characteristics. With respect to any examples or hints given herein, any typical values stated herein and/or any information regarding the application of the device, Infineon Technologies hereby disclaims any and all warranties and liabilities of any kind, including without limitation, warranties of non-infringement of intellectual property rights of any third party.

#### **Information**

For further information on technology, delivery terms and conditions and prices, please contact the nearest Infineon Technologies Office ([www.infineon.com](http://www.infineon.com)).

#### **Warnings**

Due to technical requirements, components may contain dangerous substances. For information on the types in question, please contact the nearest Infineon Technologies Office.

Infineon Technologies components may be used in life-support devices or systems only with the express written approval of Infineon Technologies, if a failure of such components can reasonably be expected to cause the failure of that life-support device or system or to affect the safety or effectiveness of that device or system. Life support devices or systems are intended to be implanted in the human body or to support and/or maintain and sustain and/or protect human life. If they fail, it is reasonable to assume that the health of the user or other persons may be endangered.

<b>1</b>	<b>Overview</b> .....	<b>5</b>
1.1	Features .....	5
1.2	Product Description .....	5
<b>2</b>	<b>Pin Configuration</b> .....	<b>6</b>
<b>3</b>	<b>Functional Block Diagram</b> .....	<b>7</b>
<b>4</b>	<b>Functional Description</b> .....	<b>8</b>
4.1	Sensor .....	8
4.2	Transfer Function .....	9
<b>5</b>	<b>Electrical Characteristics</b> .....	<b>10</b>
5.1	Absolute Maximum Ratings .....	10
5.2	Operating Range .....	11
5.3	Sensor Characteristics .....	12
5.4	Electrical Details .....	14
5.4.1	Output Voltage versus Load .....	14
5.4.2	Timings .....	15
<b>6</b>	<b>Accuracy</b> .....	<b>16</b>
6.1	Supply Voltage Influence (Ratiometric Error) .....	16
6.2	Overall Accuracy .....	17
<b>7</b>	<b>Application Circuit</b> .....	<b>18</b>
<b>8</b>	<b>Package</b> .....	<b>19</b>
<b>9</b>	<b>Package Outlines</b> .....	<b>20</b>
9.1	Package Dimensions .....	20
9.2	Cap dimensions .....	21
9.3	Footprint .....	22
<b>10</b>	<b>EMC Requirements</b> .....	<b>23</b>
10.1	EM Immunity by Direct Power Injection .....	23
10.2	EM Immunity by Electrical Fast Transients .....	23
<b>11</b>	<b>Identification Code</b> .....	<b>24</b>

**Absolute Pressure Sensor**

**Revision History: 2007-11-23, Rev 1.02**

**Previous Version: Rev 0.1**

Page	Subjects (major changes since last revision)
<a href="#">Page 5</a>	Paragraph about pressure range rephrased.
<a href="#">Page 15</a>	KP126N6165 input pressure range increased.
<a href="#">Page 16</a>	Definition ratiometric error rephrased. Formula added.

**Previous Version: Rev 0.9**

<a href="#">Page 10</a>	KP126N6165 input pressure range increased in figure.
<a href="#">Page 18</a>	Changes in recommended application circuit.
<a href="#">Page 19</a> <a href="#">Page 20</a>	Reorganization of chapters package outlines and cap.

**Previous Version: Rev 1.0**

<a href="#">Page 6</a>	Changes according to application circuit for GND connection and digital PINs.

**Previous Version: Rev 1.01**

<a href="#">Page 12</a>	Correction of sensor characteristics output referred noise.
-------------------------	---

**We Listen to Your Comments**

Any information within this document that you feel is wrong, unclear or missing at all?  
Your feedback will help us to continuously improve the quality of this document.  
Please send your proposal (including a reference to this document) to:

[sensors@infineon.com](mailto:sensors@infineon.com)



## 1 Overview

### 1.1 Features

- Ratiometric analog output
- Calibrated transfer function
- High accuracy over a large temperature range
- Maximum error  $\pm 1.0$  kPa
- “Green” 8-pin SMD housing
- On Board Diagnostics (OBD) for broken wire detection

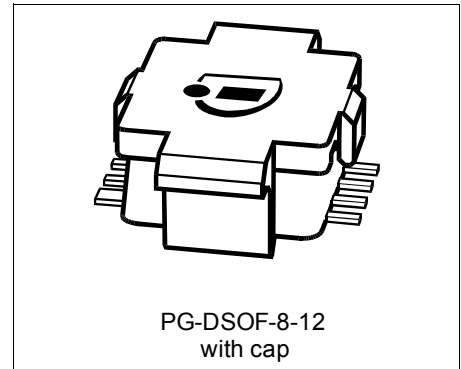

### 1.2 Product Description

The KP126N6165 is a miniaturized Absolute Pressure Sensor IC based on the capacitive principle. It is surface micromachined with a monolithic integrated signal conditioning circuit implemented in BiCMOS standard technology. Because the KP126N6165 is a high-precision IC for cost-critical solutions, the chip is packaged in a “green” low-cost SMD housing. The sensor is developed for measurement of barometric air pressure (BAP).

High accuracy and high sensitivity enable the deployment of this device in automotive applications as well as in consumer applications.

The calibrated transfer function converts a pressure range from 60 kPa to 165 kPa into an analog output voltage between 0.2 V and 4.8 V.

Product Name	Product Type	Ordering Code	Package
KP126N6165	Absolute Pressure Sensor	SP000264887	PG-DSOF-8-12

## 2 Pin Configuration

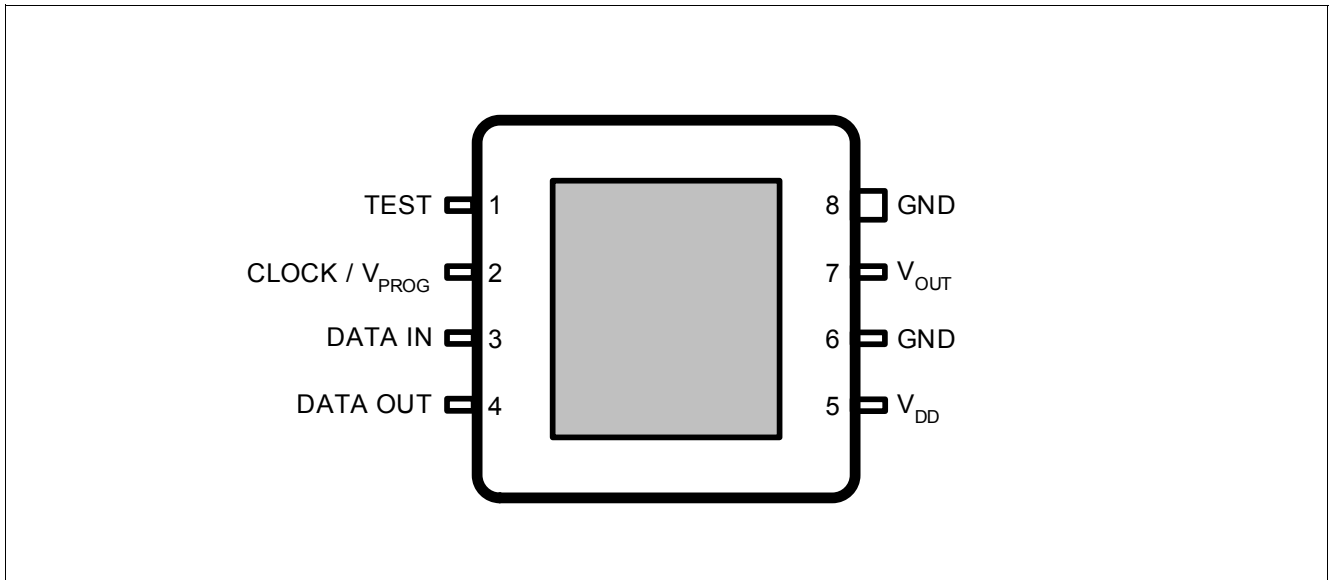

Figure 1 Pin Configuration (top view, figure not to scale)

Table 1 Pin Definitions and Functions

Pin No.	Name	Function
1	TEST	Test pin <sup>1)</sup>
2	CLOCK / V <sub>PROG</sub>	External Clock for Communication / Programming Voltage <sup>1)</sup>
3	DATA IN	Serial data input pin <sup>1)</sup>
4	DATA OUT	Serial data output pin <sup>1)</sup>
5	V <sub>DD</sub>	Supply Voltage
6	GND	0 Volt circuit ground potential <sup>2)</sup>
7	V <sub>OUT</sub>	Analog pressure signal output
8	GND	Alternative ground pin <sup>2)</sup>

1) Digital pins are used only during calibration and test. It is recommended to leave these PINs floating.

2) It is recommended to connect both GND PINs.

### 3 Functional Block Diagram

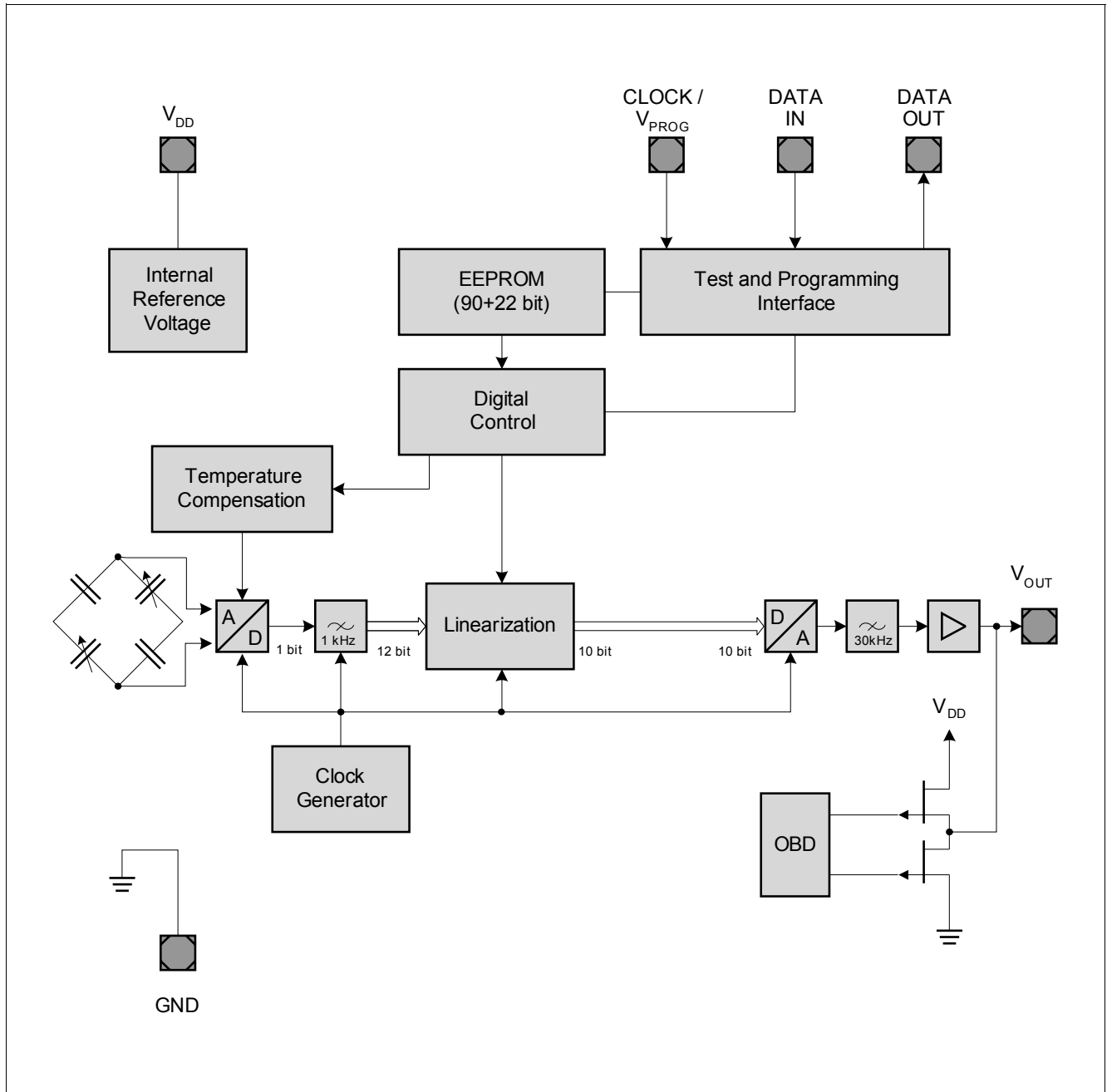

Figure 2 Block Diagram

## **4 Functional Description**

### **4.1 Sensor**

Pressure is detected in a capacitive way by an array of surface micromachined sensor cells.

The sensor cell output is amplified, temperature compensated and linearized to obtain an output voltage that is proportional to the applied pressure.

The transfer function for linearization is calculated in the digital part of the sensor using third order polynomial calculation.

The transfer function is given by the following parameters:

- Minimum and maximum rated pressure
- Voltage at minimum rated pressure
- Voltage at maximum rated pressure
- Sensitivity

The output is analog and ratiometric with respect to the supply voltage.

All parameters needed for the complete calibration algorithm — such as offset, gain, temperature coefficients of offset and gain, and linearization parameters — are determined after assembly. The parameters are stored in internal registers in the EEPROM of the chip.

#### **On Board Diagnostics**

When the chip is not powered properly, the JFET transistors of the On Board Diagnostics (OBD) stage are self-conducting. For example, if the GND connection is interrupted, the output is drawn strongly to  $V_{DD}$ . The microcontroller can set a limit for valid output signals. In the case of an error, the output voltages will be too close to the  $V_{DD}$  or  $GND$  potential.



## 4.2 Transfer Function

The KP126N6165 device is fully calibrated on delivery. The sensor has a linear transfer function between the applied pressure and the output signal:

$$V_{OUT} = V_{DD} \times (a \times P + b)$$

The output is ratiometric.

Gain **a** and Offset **b** are determined during calibration in order to create the required transfer function.

### Standard Transfer Function

The following calibration is adjusted with the parameters **a** and **b**:

**Table 2 Transfer Function (End Points)**

Pressure			Output Voltage @ $V_{DD} = V_{DD;TYP}$		
Symbol	Values	Unit	Symbol	Values	Unit
$P_{IN,MIN}$	60	kPa	$V_{OUT,MIN}$	0.2	V
$P_{IN,MAX}$	165		$V_{OUT,MAX}$	4.8	

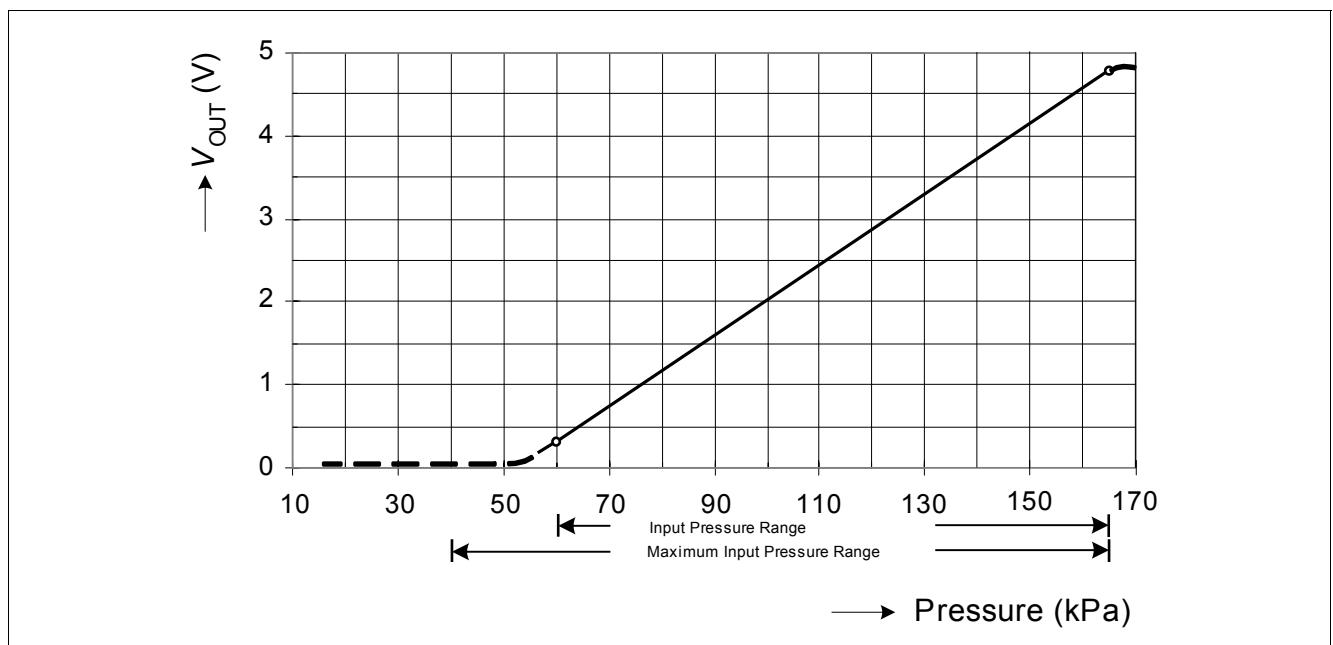

**Figure 3 Transfer Function**

*Note: The application circuitry determines the current driven by the device and thus has an impact on the diagnostic ranges.*

## 5 Electrical Characteristics

### 5.1 Absolute Maximum Ratings

**Table 3 Absolute Maximum Ratings**

Parameter	Symbol	Values			Unit	Note / Test Condition
		Min.	Typ.	Max.		
Supply voltage	$V_{DD}$	- 0.3	-	6.5	V	1h @ 70°C for max. 5 minutes
		-	-	16.5		
		- 6.5 <sup>1)</sup>	-	-		
Output voltage	$V_{OUT}$	- 0.3	-	$V_{DD} + 0.3$	V	
Maximum ambient temperature	$T_A$	- 40		125	°C	
Storage temperature	$T_S$	- 60		150	°C	
Maximum input pressure range	$P_{MAX}$	40	-	600	kPa	for max. 5 minutes
		5.8		87	psi	
		40	-	165	kPa	
		5.8		23.93	psi	
Voltage at CLOCK / $V_{PROG}$ Pin	$V_{CLK}$	-	-	20	V	
Voltage at data pins (DATA IN, DATA OUT)	$V_{DATA}$	-	-	5.0	V	
ESD robustness <sup>2)</sup>	$V_{ESD, HBM}$	-	-	± 2	kV	Analog pins: $V_{DD}$ , $V_{out}$ , GND
		-	-	± 2	kV	Digital pins: CLOCK / $V_{PROG}$ , DATA OUT, DATA IN

1) Reverse polarity;  $I_{DD} < 300\text{mA}$

2) HBM: 1.5kΩ, 100pF; according to EIA/JESD22-A114-B (covers MIL STD 883D)

**Attention: Stresses above the max. values listed here may cause permanent damage to the device. Exposure to absolute maximum rating conditions for extended periods may affect device reliability. Maximum ratings are absolute ratings; exceeding only one of these values may cause irreversible damage to the integrated circuit.**

## 5.2 Operating Range

The following operating conditions must not be exceeded in order to ensure correct operation of the device.

All parameters specified in the following sections refer to these operating conditions, unless otherwise noticed.

**Table 4 Operating Range**

Parameter	Symbol	Values			Unit	Note / Test Condition
		Min.	Typ.	Max.		
Supply voltage	$V_{DD}$	4.5	5	5.5	V	$V_{OUT}$ is ratiometric to $V_{DD}$
Output current <sup>1)</sup>	$I_{OUT}$	- 1	-	1	mA	
Lifetime	$t_{LT}$	15	-	-	years	
Maximum ambient temperature	$T_A$	- 40		125	°C	
Input pressure range	$P_{IN}$	60		165	kPa	
		8.7		23.93	psi	

- 1) Negative values: Current into device (pull-up resistor used).  
Positive values: Current out of the device (pull-down resistor used).

### 5.3 Sensor Characteristics

**Table 5 Sensor Characteristics**

Parameter	Symbol	Values			Unit	Note / Test Condition
		Min.	Typ.	Max.		
Output Voltage Range	$V_{OUT\_R}$	0.10		4.85	V	More information in chapter <a href="#">“Electrical Details” on Page 14</a>
Sensitivity	$S$	–	43.8	–	mV/ kPa	
Supply current	$I_{DD}$	–	8	10	mA	<sup>1)</sup>
Overall Accuracy Error	Err	–	–	± 1.0	kPa	<sup>2)</sup>
Ratiometric Error	$E_{RAT}$	–25	–	25	mV	<sup>3)</sup>
Output referred noise	$V_{NOISE}$	–	–	2.5	mV <sub>RMS</sub>	@ f > 1kHz <sup>4)</sup>
		–	–	1.8		@ f < 1kHz
Response time <sup>5)</sup>	$t_R$	–	1.8	–	ms	10% to 90% of the final output value
Stabilization time <sup>10)</sup>	$t_S$	–	–	10	ms	For full accuracy
Power up time <sup>10)</sup>	$t_{UP}$	–	–	5	ms	90% of the final output value
Broken wire: diagnosis response time <sup>6)</sup>	$t_{OBD}$	–	–	1	ms	
OBD Transistor On Resistance	$R_{DSON}$	–	–	160	Ω	$V_{OUT}$ to $V_{DD}$ or $V_{OUT}$ to GND, @ 25°C
Junction temperature <sup>7)</sup>	$T_j$	– 30.2		134.8	°C	
Thermal resistance	$R_{thj-amb}$		245		K/W	

1) A peak supply current of up to 22 mA is possible during power up.

2) More details in chapter [“Overall Accuracy” on Page 17](#)

3) More details in [“Supply Voltage Influence \(Ratiometric Error\)” on Page 16](#)

4) 200 measurements in sequence, bandwidth limited to 40kHz

5) More details in [“Timings” on Page 15](#)

6) In the event of a broken wire (broken  $V_{DD}$  line or broken GND line), the output changes to certain voltage levels within the broken wire response time.

7)  $T_{junction} = T_{ambient} + \Delta T_{c,j}$  (in steady-state condition, typical operation conditions)

## 5.4 Electrical Details

### 5.4.1 Output Voltage versus Load

The output voltage limits depend on:

- the value of the external load resistor
- the connection mode (pull-up or pull-down)

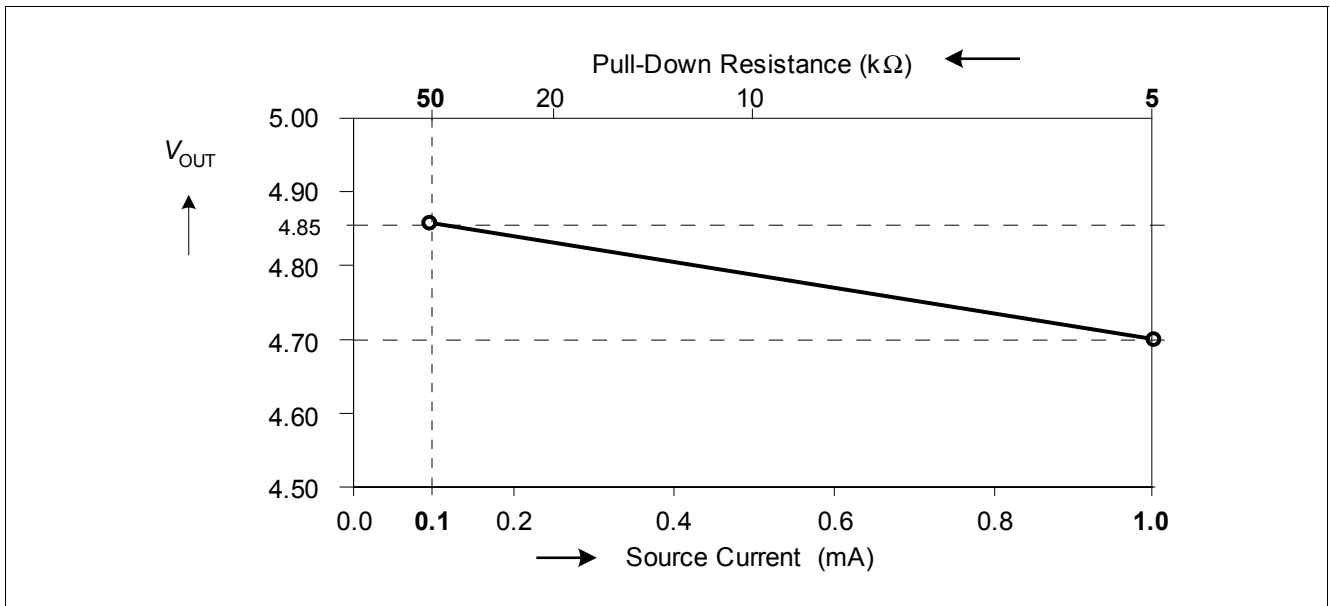

Figure 4 Maximum Output Voltage Limit at Maximum Rated Pressure with Pull-Down Load

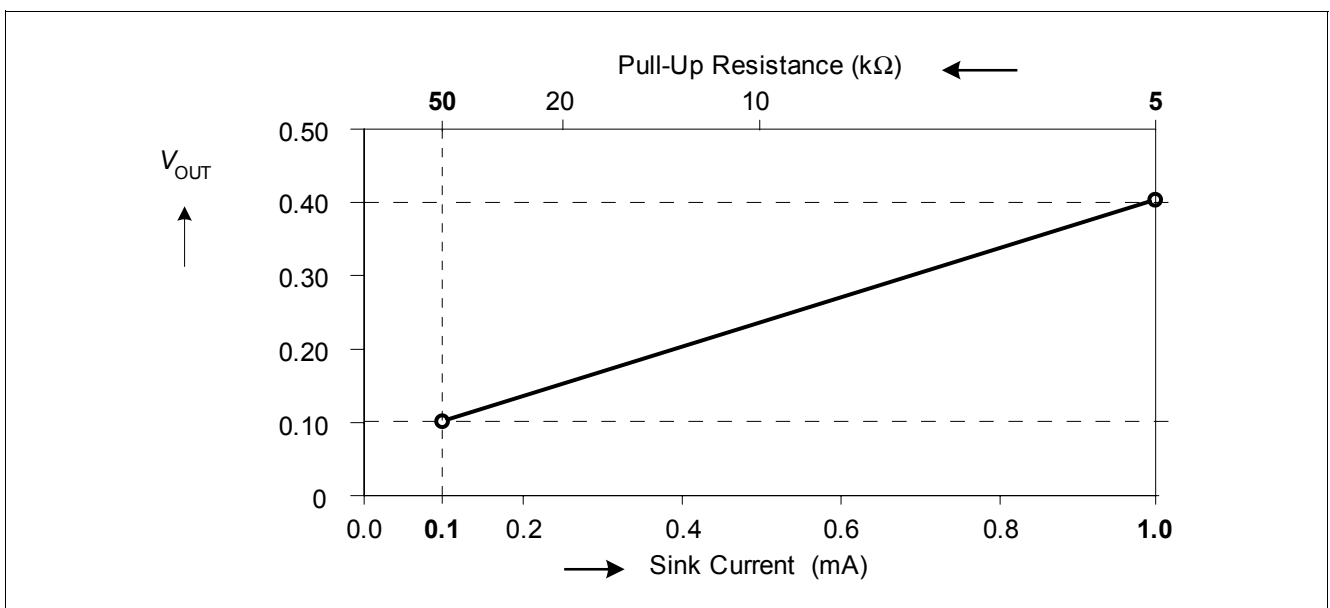

Figure 5 Minimum Output Voltage Limit at Minimum Rated Pressure with Pull-Up Load

Note: The values in the diagrams are valid for the entire specified temperature range.

## 5.4.2 Timings

### Power-up Time

The power-on time  $t_{UP}$  is defined as the maximum time between the supply voltage reaching its operating range and the output voltage reaching 90% of its final value.

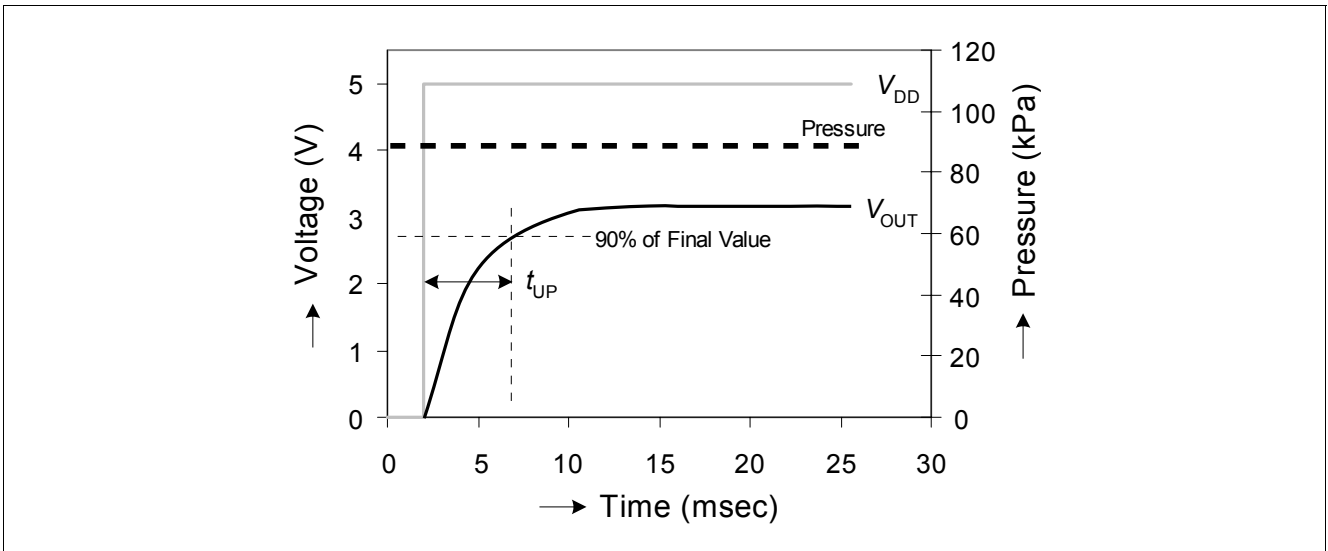

Figure 6 Power-up Time

### Response Time and Stabilization Time

The Response Time  $t_R$  is defined as the time for the incremental output change to go from 10% to 90% of its final value after a specified pressure step.

The Stabilization Time  $t_S$  is defined as the time required for the output voltage to meet the specified accuracy after the pressure has been stabilized.

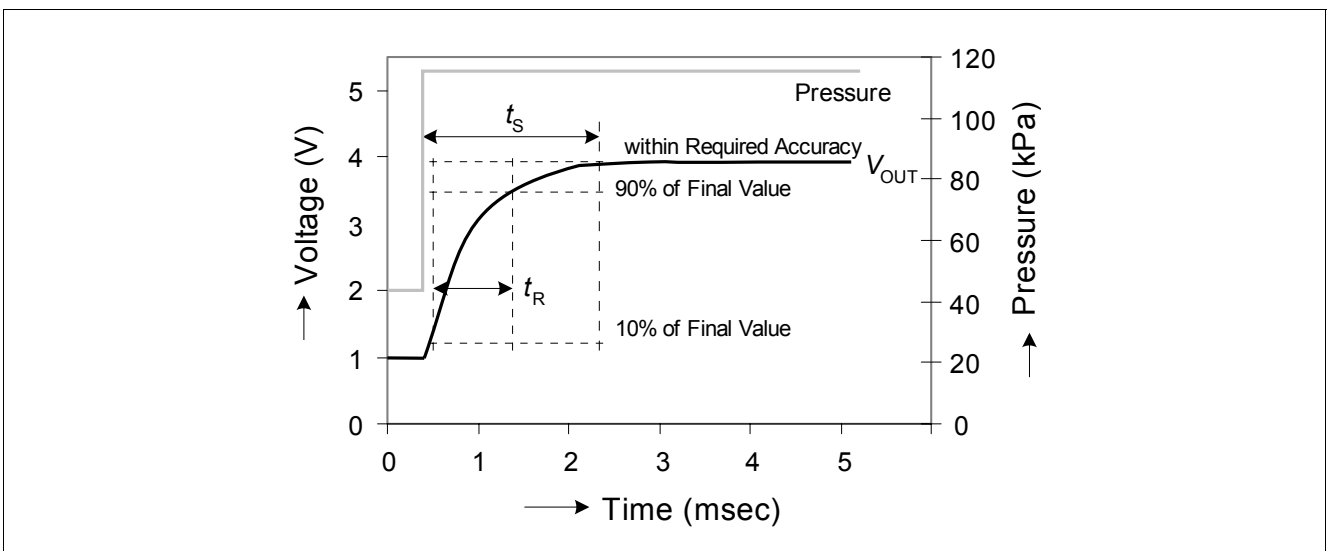

Figure 7 Response Time and Stabilization Time

## 6 Accuracy

The accuracy of the KP126N6165 sensor is influenced by the supply voltage (ratiometric error) and by pressure, temperature and aging. The specified value represents the theoretical value, when the actual pressure is multiplied with the transfer function, see [Figure 8](#). The error equals the deviation between the measured output voltage value and the specified output voltage value.

### 6.1 Supply Voltage Influence (Ratiometric Error)

#### Definition

Ideally, the sensor is ratiometric – the output ( $V_{OUT}$ ) scales by the same ratio that  $V_{DD}$  increases or decreases. The ratiometric error is defined as the difference between the ratio that  $V_{DD}$  changed and the ratio that  $V_{OUT}$  changed, expressed as a percentage:

$$E_{RAT} (\%) = \frac{V_{OUT}(@V_{DD}) - V_{OUT}(@5V) \times \frac{V_{DD}}{5V}}{5V} \times 100\%$$

The output voltage  $V_{OUT}$  is ratiometric to  $V_{DD}$ , within the range provided in [Table 5](#).

$V_{DD}$  must be within the operating range specified in [Table 4](#).

**Table 6 Ratiometric Error**

Supply Voltage (V)	Max. Ratiometric Error (% of $V_{DD,TYP}$ )
$V_{DD,MIN}$	± 0.5
$V_{DD,TYP}$	0
$V_{DD,MAX}$	± 0.5

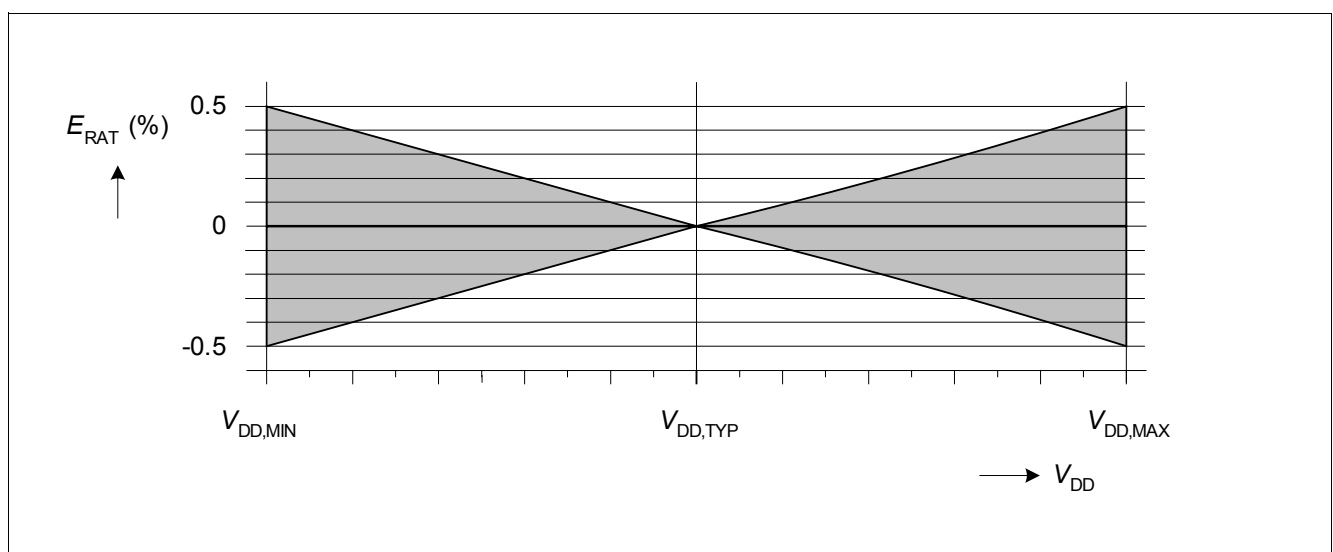

**Figure 8 Ratiometric Error**

## 6.2 Overall Accuracy

Overall accuracy covers the entire pressure and temperature range from all sources of error including the following:

- **Pressure:**  
Output deviation from target transfer function over the specified pressure range.
- **Temperature:**  
Output deviation over the temperature range.
- **Aging**  
All drifting parameters during operating time.

*Note: Ratiometric signal error is not included in the overall accuracy. For error measurements, the supply voltage must have the nominal value ( $V_{DD} = V_{DD,TYP}$ ).*

The error band is determined by three continuous lines through four relevant break points:

**Table 7 Accuracy**

Temperature Point (°C)	Error (kPa)	Error Multiplier
-40	± 2.0	2
0	± 1.0	1
85	± 1.0	1
125	± 2.0	2

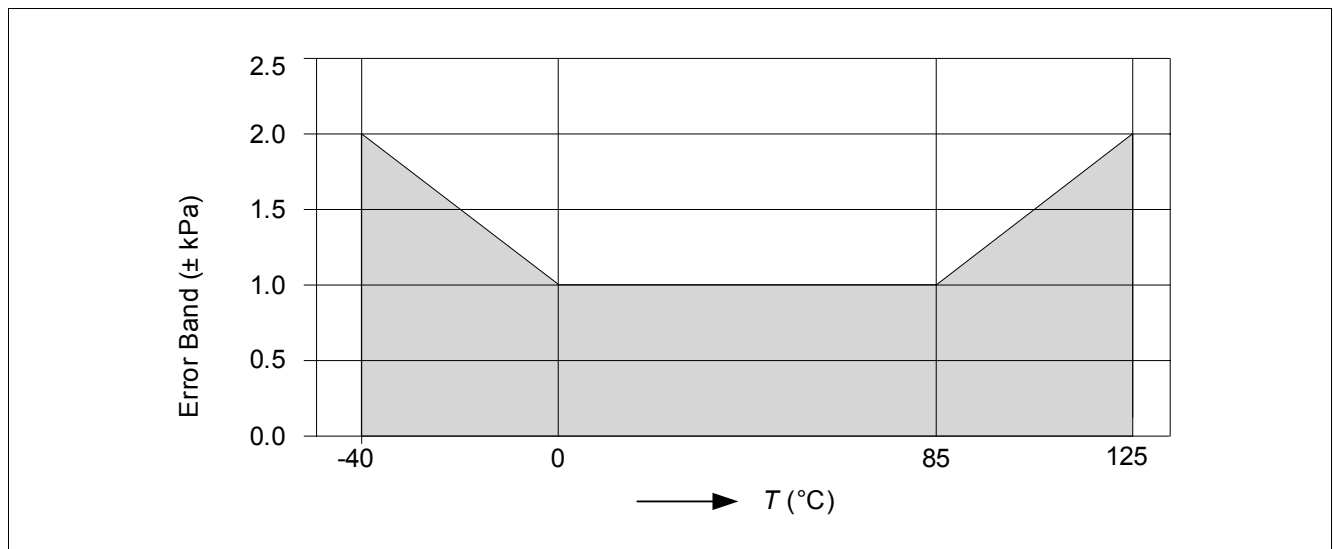

**Figure 9 Overall Error Over Temperature**



## 7 Application Circuit

It is recommended to protect the KP126N6165 pressure sensor IC against overload voltage and electro-magnetic interference (as shown in **Figure 10**).

The output circuitry acts as a low-pass decoupling filter between the sensor IC output and the A/D input of the microcontroller.

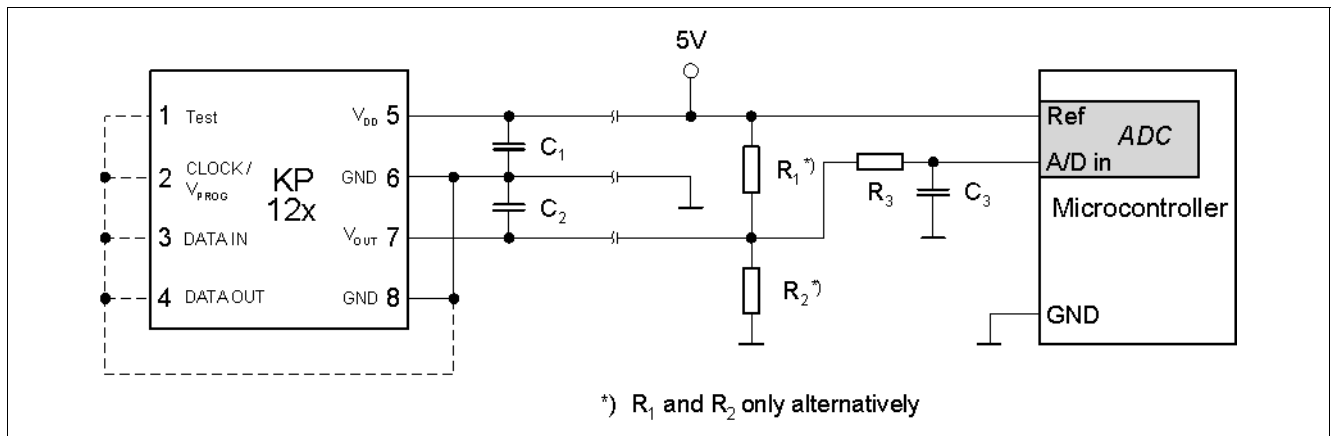

**Figure 10 Application Circuitry for Evaluation**

*Note: It is recommended to leave digital PINs CLOCK/ $V_{PROG}$ , DATA IN and DATA OUT floating. If these PINs are grounded, it is recommended to connect both GND PINs.*

**Table 8 Component Values**

Component	Symbol	Values			Unit	Note
		Min.	Typ.	Max.		
Pull-Up Resistor	$R_1$	5	59	100	k $\Omega$	Only 1 resistor allowed
Pull-Down Resistor	$R_2$	5	59	100	k $\Omega$	
Low Pass Resistor	$R_3$	3.9	22	100	k $\Omega$	
Supply Blocking Capacitor	$C_1$	10	100	100	nF	
Output Blocking Capacitor	$C_2$	0	100	100	nF	
Low Pass Capacitor	$C_3$	10	100	100	nF	

*Note: The value of load resistor  $R_1$  or  $R_2$  determines the current driven by the device.*

## **8 Package**

As well as using “green” materials, the PG-DSOF-8-12 package is optimized regarding mechanical stress influences. The package fulfills the solder conditions for lead-free board assembly.

In the application it is recommended to ensure that the same pressure is applied to the whole package.

The KP126N6165 is supplied with a removable plastic cap (refer to [Figure 12](#)). The flat surface of this cap on top of the package allows handling with standard pick-and-place tools.

After soldering the device to the printed circuit board (PCB), the cap on the PG-DSOF-8-12 may be removed. When removing the protective cap, care should be taken to avoid damage to the device.

In some applications, such as for barometric measurements, it may be appropriate to leave the protective cap on the package after the soldering process. Damage to the gel is prevented. The four splits in the cap side allow a sufficient pressure coupling.



## 9.2 Cap dimensions

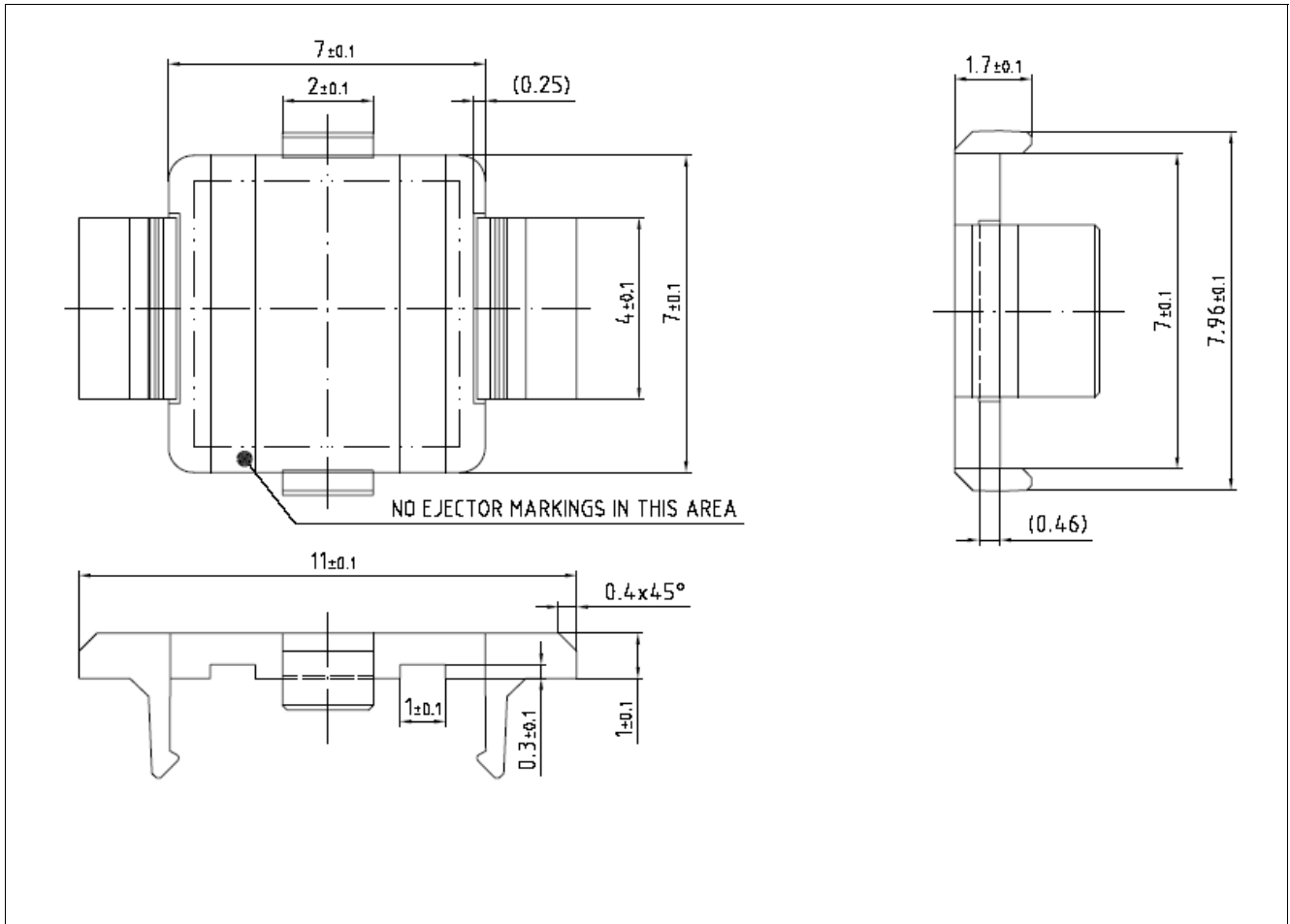

Figure 12 Cap Dimensions

### 9.3 Footprint

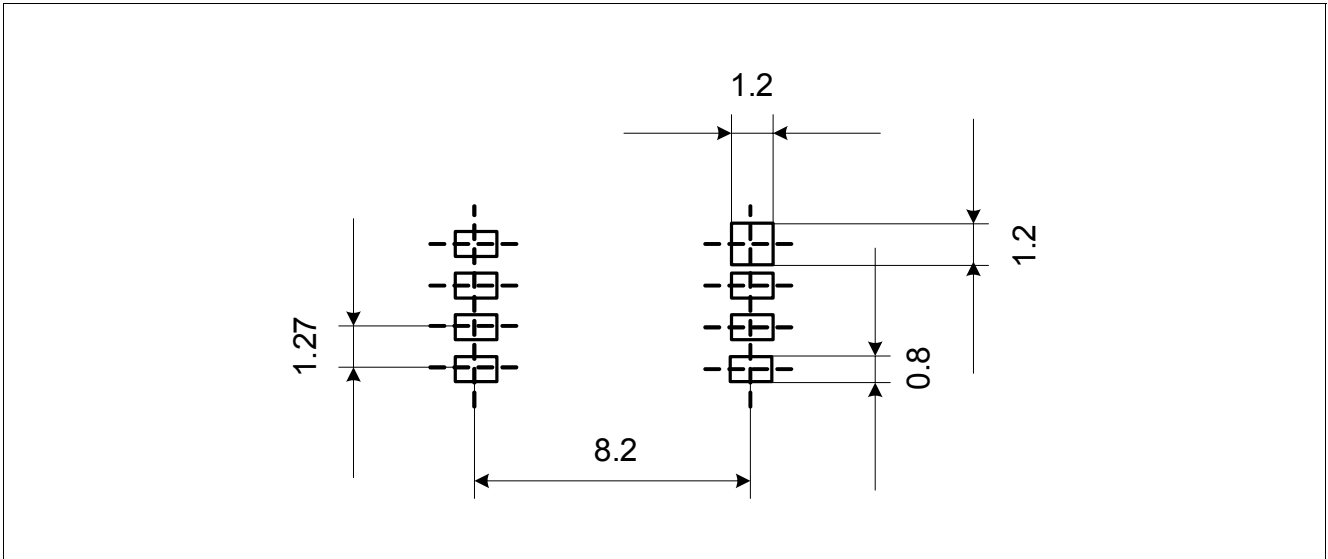

Figure 13 Footprint

## 10 EMC Requirements

### 10.1 EM Immunity by Direct Power Injection

The KP126N6165 test is compliant to EMC requirements for Direct Power Injection (DPI) described in

- ISO 11452-7 11-95
- IEC 62132-3 01-00.

### 10.2 EM Immunity by Electrical Fast Transients

The KP126N6165 test is compliant to EMC requirements for Electrical Fast Transients (EFT) according to the hardware set up shown in [Figure 14](#), which is based on

- ISO 7637-1 08-00
- ISO/CD 7637-2 02-99
- ISO 7637-3 11-95

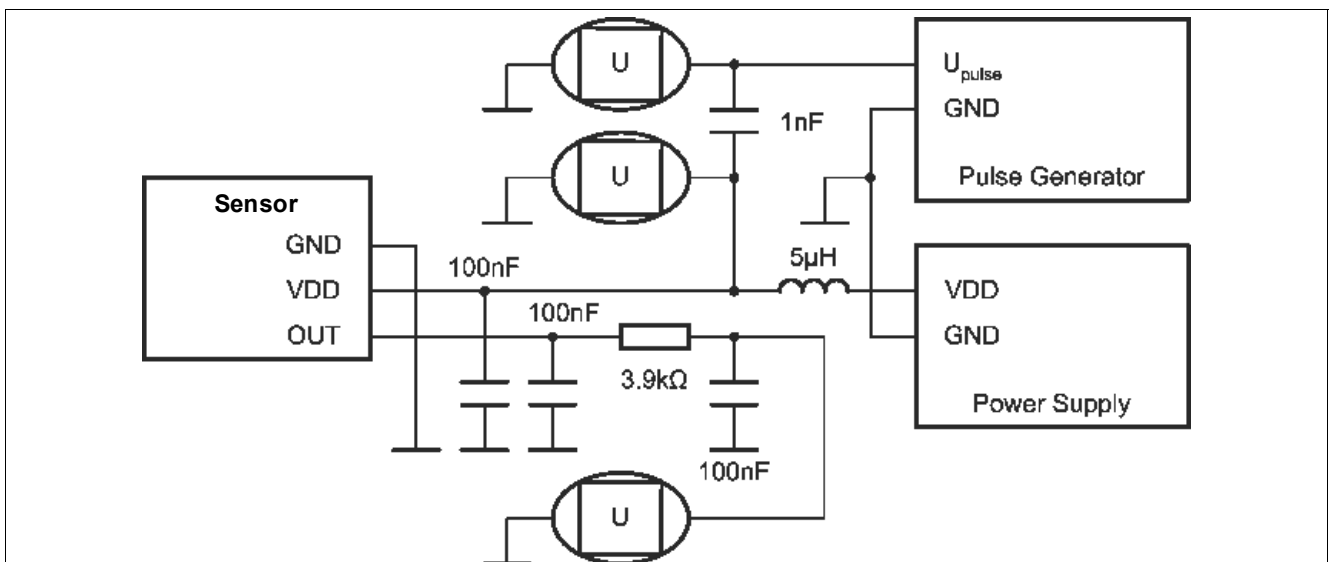
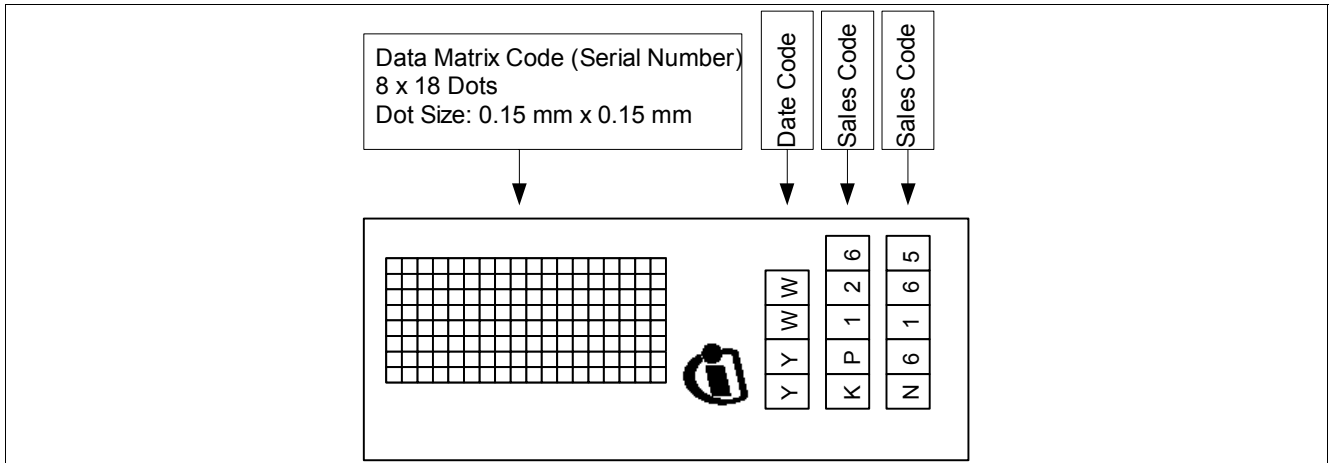

Figure 14 Hardware Set Up for Electrical Fast Transients

## 11 Identification Code

The identification code is provided in a machine-readable format. The date and sales code are provided in human-readable format.



**Figure 15** Sensor Identification Code

The marking for the KP126N6165 is on the same side of the package as pin 8.

Date code definition:

WW: work week (1...53)

YY: year (06...99)

Data Matrix Code: 8 x 18 Dots, Dot Size: 0.15 mm x 0.15 mm

[www.infineon.com](http://www.infineon.com)