

IPS / 1000cd/m² with PCAP / mounting frame



Left: EA R1024X-70ALW with mounting bezel
Right: EA R1024X-70BLWTS no bezel but with PCAP

FEATURES

- 7" TFT – HIGH RESOLUTION 1024x600 DOTS
- IPS TECHNOLOGY FOR WIDEST VIEWING ANGLE >160° AND TRUE COLORS
- HIGH BRIGHTNESS (1000cd/m²) FOR SUNLIGHT READABILITY
- LVDS 6/8 BIT INTERFACE
- -70ALW: INCL. MOUNTING FRAME FOR PCB MOUNT
- -70BLW: NO MOUNTING FRAME
- -70BLWTS: INCL. PCAP TOUCHPANEL AND CONTROLLER GT911 (I²C) FOR 5 FINGER OPERATION

ORDERING INFORMATION

7" TFT IPS - 1024x600 DOTS, LVDS INCL. MOUNTING FRAME

7" TFT IPS - 1024x600 DOTS, LVDS

7" TFT IPS - 1024x600 DOTS, LVDS WITH PCAP (GT911)

EA R1024X-70ALW

EA R1024X-70BLW

EA R1024X-70BLWTS

ACCESSORY

PCAP CAPACITIVE TOUCH PANEL 7" FOR "-70ALW" INCL. GT928

ZIFF CONNECTOR FOR TFT, 40 PINS 0.5mm BOTTOM CONTACT

ZIFF CONNECTOR FOR TFT, 40 PINS 0.5mm TOP CONTACT

ZIFF CONNECTOR FOR PCAP, 6 PINS 1.0mm BOTTOM CONTACT

EA TOUCH1024-70C1

EA WF050-40S

EA WF050-40ST

EA WF100-06S

REVISION HISTORY

Date	Rev.	Page	Description
2017-06-26	1.0	All	First Issue
2018-11-26	1.0	1, 14, 19	Ordering code changed to „...TS“
2020-06-29	1.0	1,18, 20	Adding EA R1024X-ALW and EA TOUCH1024-70C1
2020-12-30	1.0	1, 18	Adding pictures (1) and text (18)

Contents

- GENERAL FEATURES
- ABSOLUTE MAXIMUM RATINGS
- ELECTRICAL SPECIFICATIONS
- OPTICAL SPECIFICATIONS
- BLOCK DIAGRAM
- PIN DESCRIPTION
- TIMING CHARACTERISTICS
- PCAP TOUCHPANEL
- OUTLINE DIMENSION
- RELIABILITY AND INSPECTION STANDARD
- PRECAUTIONS

1. General Features

Item	Spec	Remark
Display Mode	Normally Black transmissive	
Viewing Direction	Free	
Input Signals	LVDS 6/8 bits	
Outside Dimensions(mm)	169 (W) x105(H) x12.1 (D)	-ALW with frame
Outside Dimensions(mm)	164.9 (W) x100(H) x5.7 (D)	-BLW
Outside Dimensions(mm)	164.9 (W) x100(H) x7.6 (D)	-BLWTS
Active Area(mm)	154.21(W) × 85.92(H)	
Number of Pixels	1024(RGB) × 600	
Dot Pitch(mm)	0.1506 (H) x 0.1432 (V)	
Pixel Arrangement	RGB Vertical stripes	
CTP Drive IC (optional)	GT911 / GT928	

2. Absolute Maximum Ratings

The following are maximum values which, if exceeded may cause operation or damage to the unit.

ITEM	Sym.	Min.	Typ.	Max.	Unit	Remark
Power for Circuit Driving	VDD	-0.3	-	3.96	V	
	AVDD	-0.5		14.85	V	
	VGH	-0.3		40	V	
	VGL	-20		0.3	V	
Storage Humidity	H _{ST}	10	-		%RH	At 25±5°C
Storage Temperature	T _{ST}	-30	-	80	°C	
Operating Ambient Humidity	H _{OP}	10	-		%RH	
Operating Ambient temperature	T _{OP}	-20	-	70	°C	

3. Electrical Specification

3.1 Driving TFT LCD Panel

Item	Symbol	Min.	Typ.	Max.	Unit	Note
Supply Voltage	DV _{DD}	3.0	3.3	3.6	V	
	V _{GH}	17	18	19	V	
	V _{GL}	-6.6	-6	-5.4	V	
	AV _{DD}	9.4	9.6	9.8	V	
	V _{com}	3.6	3.8	4.0		
Video signal amplitude (VR, VG, VB)	V _{IA}	-	-	AV _{DD} -0.4	V	
	V _{IAC}	-	-	-	V	AC component,
	V _{IDC}	-	AV _{DD} /2	-	V	DC component
VCOM	V _{CAC}		-	-	VP-P	AC component
	V _{CDC}	-	-	-	V	DC component, (1)
Input signal voltage	V _{IH}	0.7DV _{DD}	-	DV _{DD}	V	(2)
	V _{IL}	0	-	0.3DV _{DD}	V	(2)
Current of power supply	I _{DD}	-	30	45	mA	DV _{DD} =3.3V
	I _{ADD}	-	35	45	mA	AV _{DD} =9.6V
	I _{GH}	-	0.5	1	uA	V _{GH} =18V
	I _{GL}	-	0.5	1	mA	V _{GL} =-6V

Note (1): The brightness of LCD panel could be changed by adjusting the AC component of VCOM.

Note (2): STHL, STHR, OEH, L/R, CPH1~CPH3, STVD, STVU, OEV, CKV, U/D

3.2 Driving LED Backlight

Item	Sym.	Min	Typ.	Max	Unit	Note
Backlight driving voltage	V _F	9.0	9.6	10.2	V	
Backlight driving current	I _F	-	270	-	mA	
Backlight Power Consumption	W _{BL}	-	2592	-	mW	
Life Time	-	-	30,000	-		Note 1

Note 1: If LED is driven by high current, high ambient temperature & humidity condition. The life time of LED will be reduced. Operating life means brightness goes down to 50% of initial brightness. Typical life time is estimated data.

3.3 Power Consumption

ITEM	SYMBOL	CONDITION	MIN	TYPE	MAX	UNIT	NOTE
Gate on power current	IVGH	VGH = 18V	--	0.5	1	mA	Note1
Gate off power current	IVGL	VGL= -6V	--	0.5	1	mA	Note1
Digital power current	IDVDD	DVDD = 3.3V	--	30	45	mA	Note1
Analog power current	IAVDD	AVDD = 9.6V	--	35	45	mA	Note1
Total Power Consumption	PC		--	447	604	mW	Note1

Note1: Typ. specification : Gray-level test Pattern
Max. specification : Black test Pattern



256 gray pattern



Black Pattern

3.4 Driving CTP

Item	Value
Working Voltage	DC 3.3V
Interface	I2C
Support Touch	5 Points

4. Optical Specifications

Optical characteristics are determined after the unit has been 'ON' and stable for approximately 30 minutes in a dark environment at 25 °C. The values specified are at an approximate distance 500mm from the LCD surface at a viewing angle of Φ and θ equal to 0°.

Item	Sym.	Values			Unit	Note
		Min.	Typ.	Max.		
1) Contrast Ratio	C/R	-	800	-		FIG.1
2) Module Luminance	L	-	1000	-	cd/m ²	w./o. CTP
		-	800	-		After CTP
3) Response time	Tr+Tf	-	35	-	ms	FIG.2
4) Viewing Angle	θ_T	-	85	-	Degree	FIG.3
	θ_B	-	85	-		
	θ_L	-	85	-		
	θ_R	-	85	-		
5) Chromaticity	Wx	0.27	0.31	0.35		
	Wy	0.29	0.33	0.37		
	Rx	-	-	-		
	Ry	-	-	-		
	Gx	-	-	-		
	Gy	-	-	-		
	Bx	-	-	-		
	By	-	-	-		

◆ **Measurement System**

Notes:

1. Contrast Ratio(CR) is defined mathematically as :

$$\text{Contrast Ratio} = \frac{\text{Surface Luminance with all white pixels}}{\text{Surface Luminance with all black pixels}}$$

2. Surface luminance is the center point across the LCD surface 500mm from the surface with all pixels displaying white. For more information see FIG 1.

3. Response time is the time required for the display to transition from white to black (Rising Time, T_r) and from black to white (Falling Time, T_f). For additional information see FIG 2.

4. Viewing angle is the angle at which the contrast ratio is greater than 10. The angles are determined for the horizontal or x axis and the vertical or y axis with respect to the z axis which is normal to the LCD surface. For more information see FIG 3.

FIG. 1 Optical Characteristic Measurement Equipment and Method

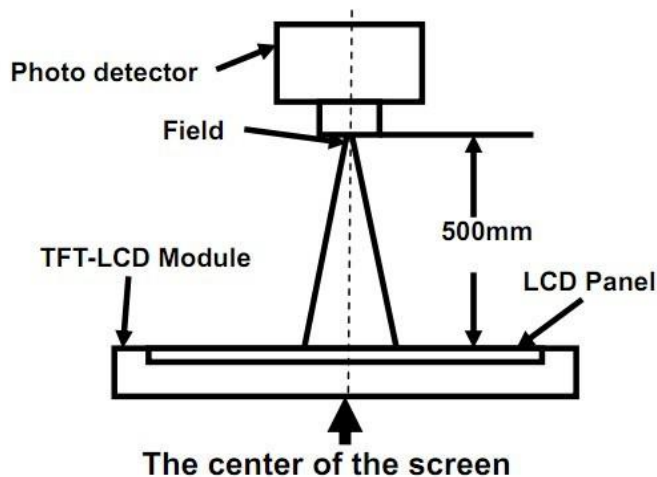

Item	Photo detector	Field
Contrast Ratio	SR-3A	1°
Luminance		
Chromaticity		
Lum Uniformity		
Response Time	BM-7A	2°

FIG. 2 The definition of Response Time

The response time is defined as the following figure and shall be measured by switching the input signal for “black” and “white”.

Response Time = Rising Time(T_r) + Falling Time(T_f)

- Rising Time(T_r) : Full White 90% → Full White 10% Transmittance.
- Falling Time(T_f) : Full White 10% → Full White 90% Transmittance.

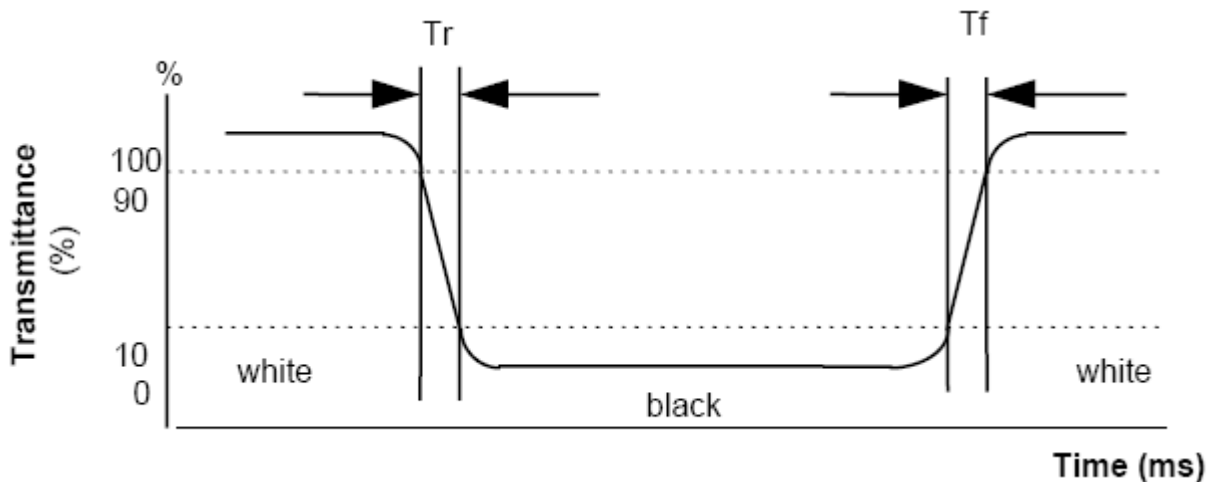
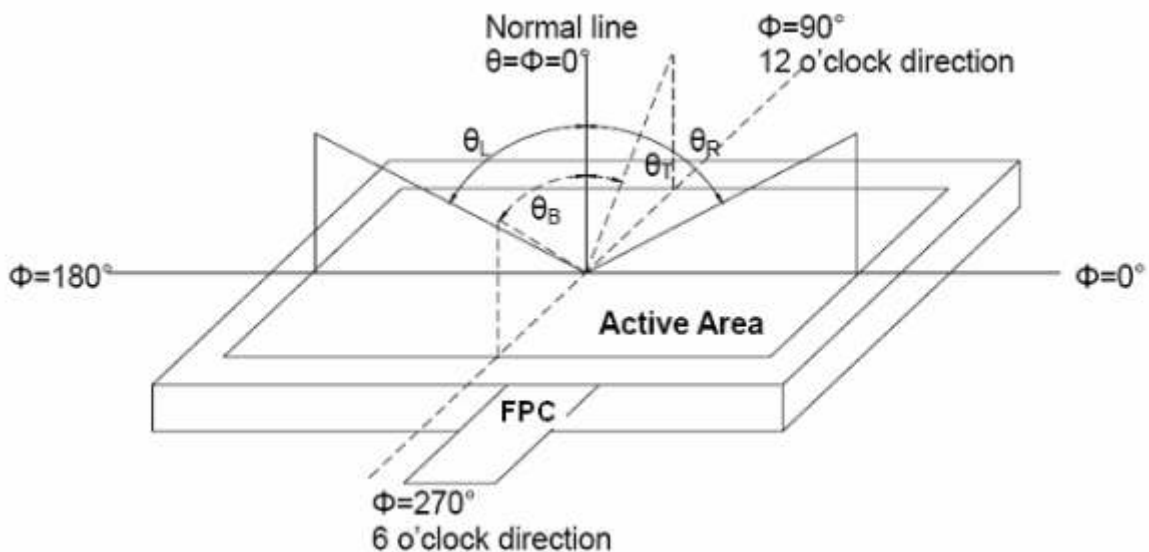
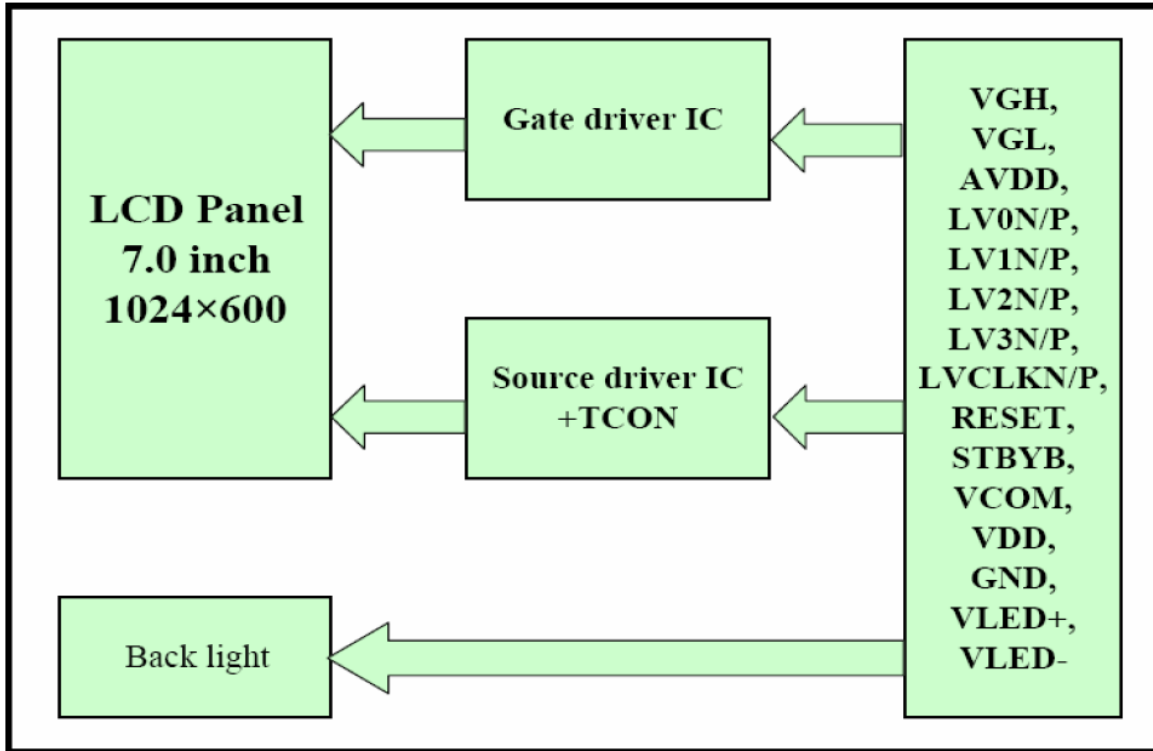

FIG. 3 The definition of Viewing Angle

Use Fig. 1(Test Procedure) under Measurement System to measure the contrast from the measuring direction specified by the conditions as the following figure.



5. Block Diagram



6.Pin Description

6.1 TFT LCD Panel

Pin No.	Symbol	I/O	Function	Remark
1	VCOM	P	Common Voltage	
2	VDD	P	Power Voltage for digital circuit	
3	VDD	P	Power Voltage for digital circuit	
4	NC	---	No connection	
5	Reset	I	Global reset pin	
6	STBYB	I	Standby mode, Normally pulled high STBYB = "1", normal operation STBYB = "0", timing controller, source driver will turn off, all output are High-Z	
7	GND	P	Ground	
8	RXIN0-	I	- LVDS differential data input	
9	RXIN0+	I	+ LVDS differential data input	
10	GND	P	Ground	
11	RXIN1-	I	- LVDS differential data input	
12	RXIN1+	I	+ LVDS differential data input	
13	GND	P	Ground	
14	RXIN2-	I	- LVDS differential data input	
15	RXIN2+	I	+ LVDS differential data input	
16	GND	P	Ground	
17	RXCLKIN-	I	- LVDS differential clock input	
18	RXCLKIN+	I	+ LVDS differential clock input	
19	GND	P	Ground	
20	RXIN3-	I	- LVDS differential data input	
21	RXIN3+	I	+ LVDS differential data input	
22	GND	P	Ground	
23	NC	---	No connection	

24	NC	---	No connection	
25	GND	P	Ground	
26	NC	---	No connection	
27	NC	-		
28	SELB	I	6bit/8bit mode select	Note1
29	AVDD	P	Power for Analog Circuit	
30	GND	P	Ground	
31	LED-	P	LED Cathode	
32	LED-	P	LED Cathode	
33	L/R	I	Horizontal inversion 80	Note3
34	U/D	I	Vertical inversion	Note3
35	VGL	P	Gate OFF Voltage	
36	NC			
37	NC			
38	VGH	P	Gate ON Voltage	
39	LED+	P	LED Anode	
40	LED+	P	LED Anode	

I: input, O: output, P: Power

Note1: If LVDS input data is 6 bits ,SELB must be set to High;

If LVDS input data is 8 bits ,SELB must be set to Low.

Note2: When CABC_EN="00", CABC OFF.

When CABC_EN="01", user interface image.

When CABC_EN="10", still picture.

When CABC_EN="11", moving image.

When CABC off, don't connect DIMO, else connect it to backlight.

Note3: When L/R="0", set right to left scan direction.

When L/R="1", set left to right scan direction.

When U/D="0", set top to bottom scan direction.

6.2 U/D R/L Function Description

Scan Control Input		Scanning Direction
UPDN	SHLR	
GND	VDD	Up to Down, Left to Right
VDD	GND	Down to Up, Right to Left
GND	GND	Up to Down, Right to Left
VDD	VDD	Down to Up, Left to Right

6.3 TFT incl. PCAP Pin Description (EA R1024X-70BLWTS only)

Pin	Symbol	Description
1	SDA	I2C data
2	SCL	I2C clock
3	RST	Reset
4	INT	Interrupt
5	VDD	Working voltage 3.3V
6	GND	GND

CTP IC driver GT911 source code will be offered separately

7. Timing characteristics and input format

7.1 Data Input format

7.1.1. 6-Bit LVDS

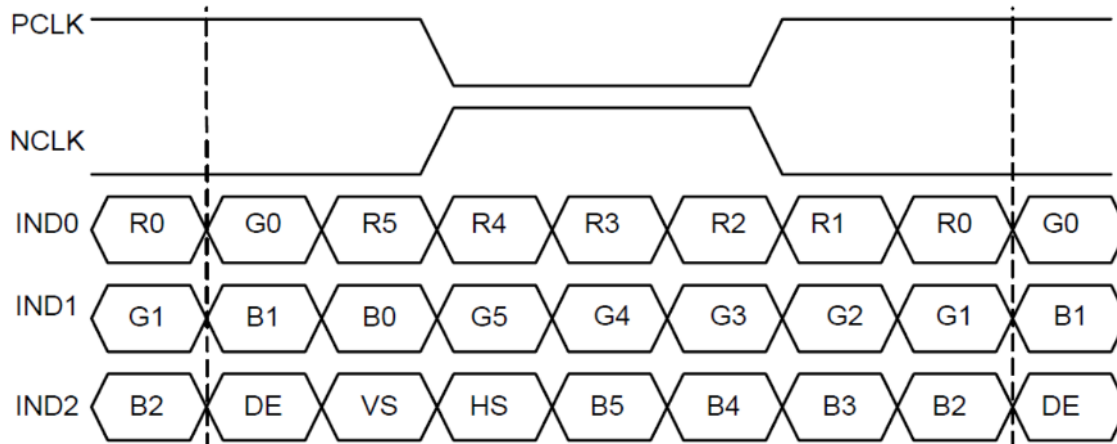

7.1.2. 8-Bit LVDS

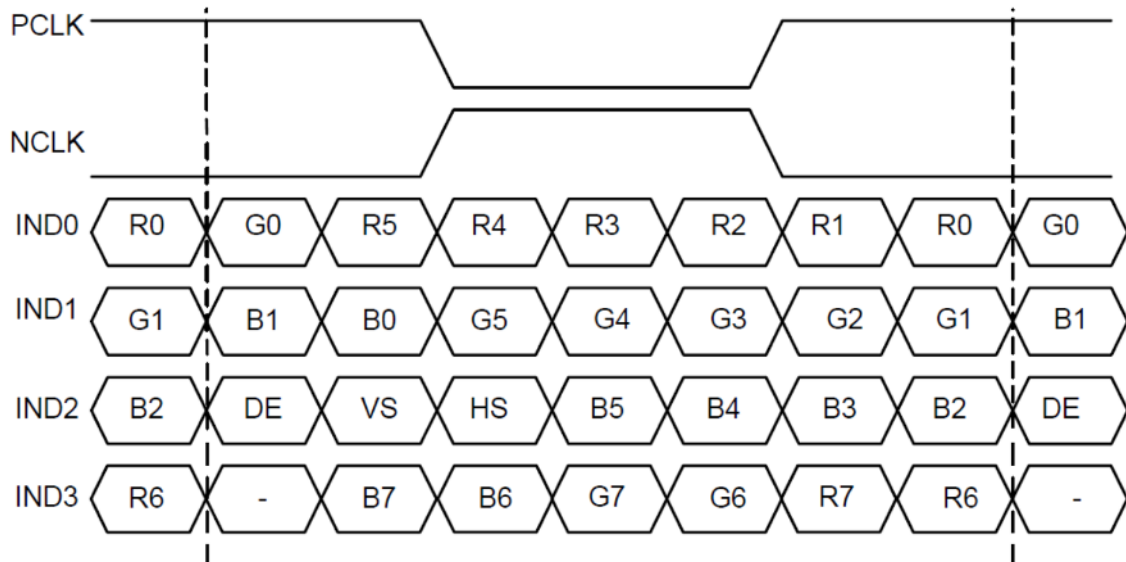

7.1.3. AC characteristics

Parameter	Symbol	Condition	Min.	Typ.	Max.	Unit
Clock Frequency	R_{XFCLK}		20	-	71	MHz
Input data skew margin	TR_{SKM}	$V_{ID} = 400mV$ $R_{XVCM} = 1.2V$ $R_{XFCLK} = 71MHz$	500			ps
Clock High Time	TL_{VCH}			4/(7* R_{XFCLK})		ns
						ns
Clock Low Time	TL_{VCL}			3/(7* R_{XFCLK})		ns
PLL wake-up-time	T_{enPLL}				150	us

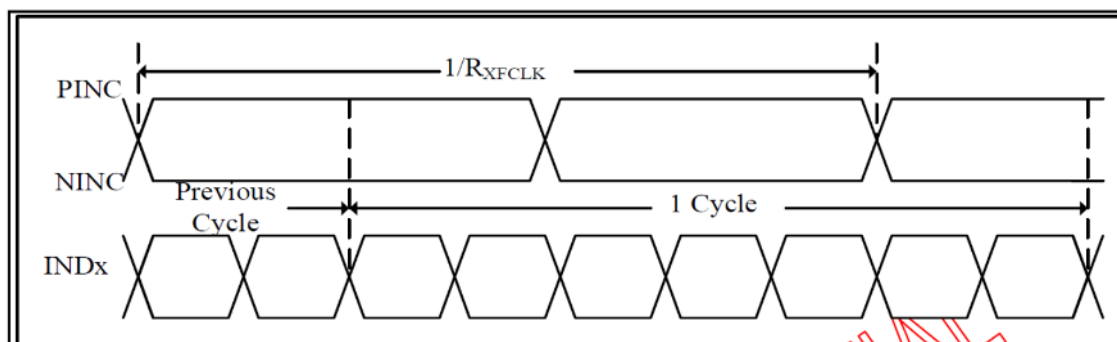

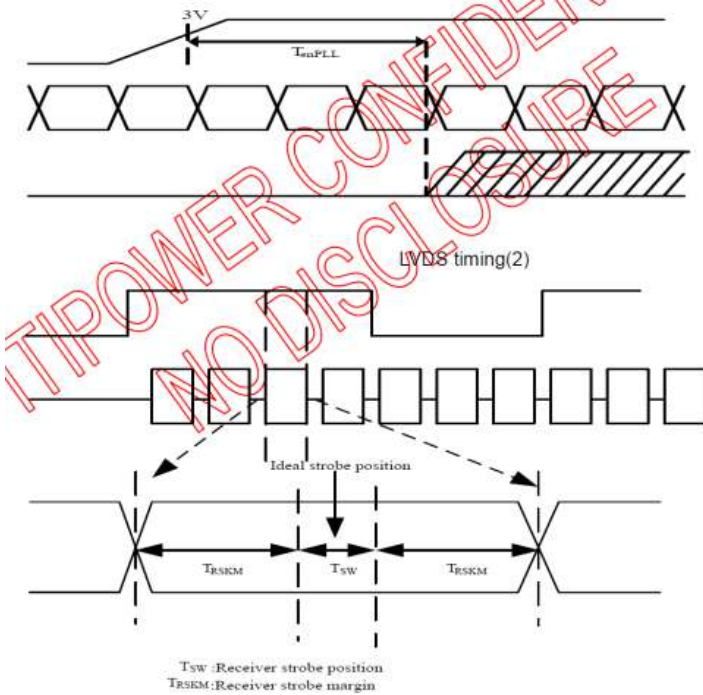

7.2 Power On/Off Sequence

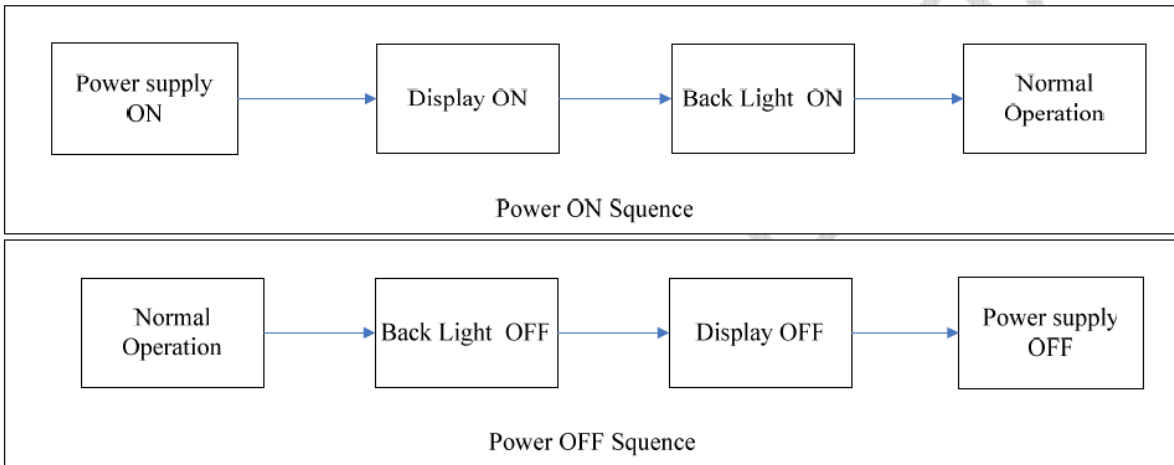
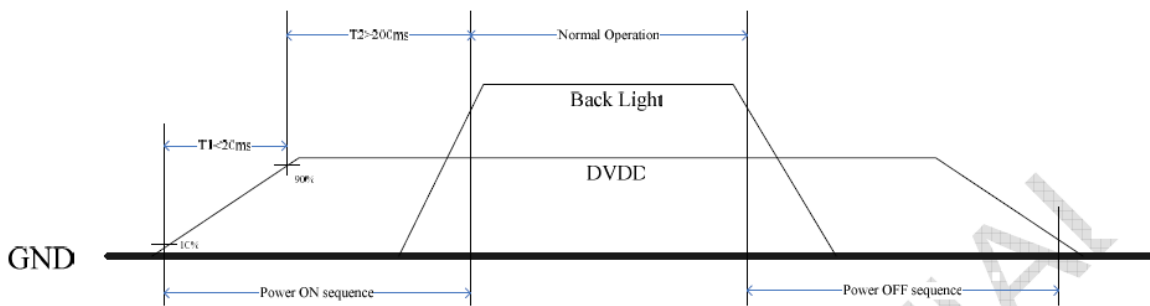

8. Touchpanel EA TOUCH1024-70C1

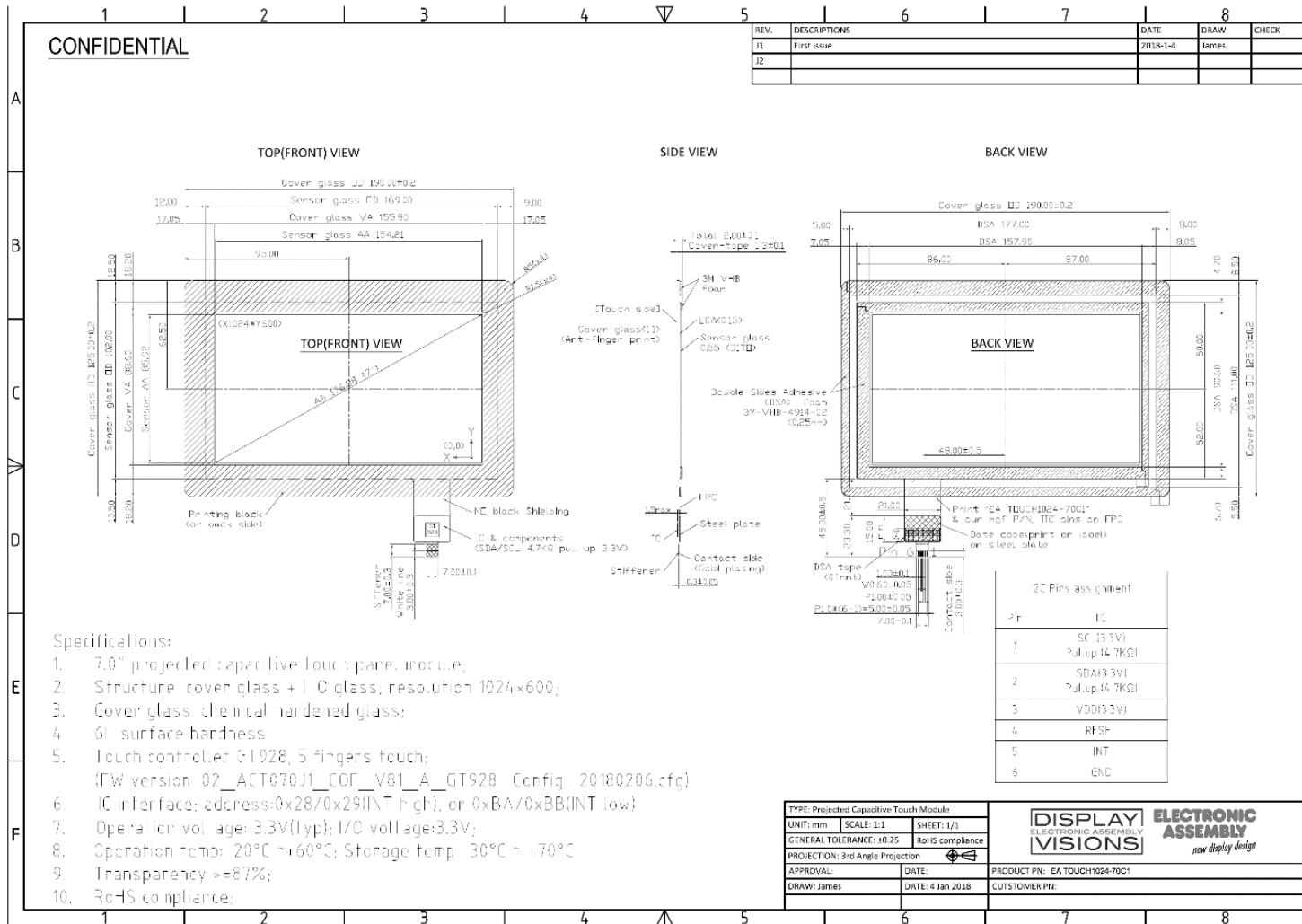

The EA TOUCH1024-70C1 is a Projected Capacitive Touchpanel (PCAP). With its resolution of 1024x600 it matches perfectly to the display incl. mounting frame EA R1024X-70ALW.

Surface is glass with 6H hardness incl. anti-finger-print coating.

There's a controller GT928 integrated that provides an I²C bus interface (address 0x28/0x29 or 0xBA/0xBB). It is good for up to 10 finger action and provides direct coordinates for up to 5 finger action.

Outside of viewing area is a black cover printing. On the rear side is a double side adhesive glue for mounting abilities to display frame or frontal plate. It's preferred to use outer adhesive for front plate only and fixing the display by metal frame.

9.1 Outline Dimension EA R1024X-BLW

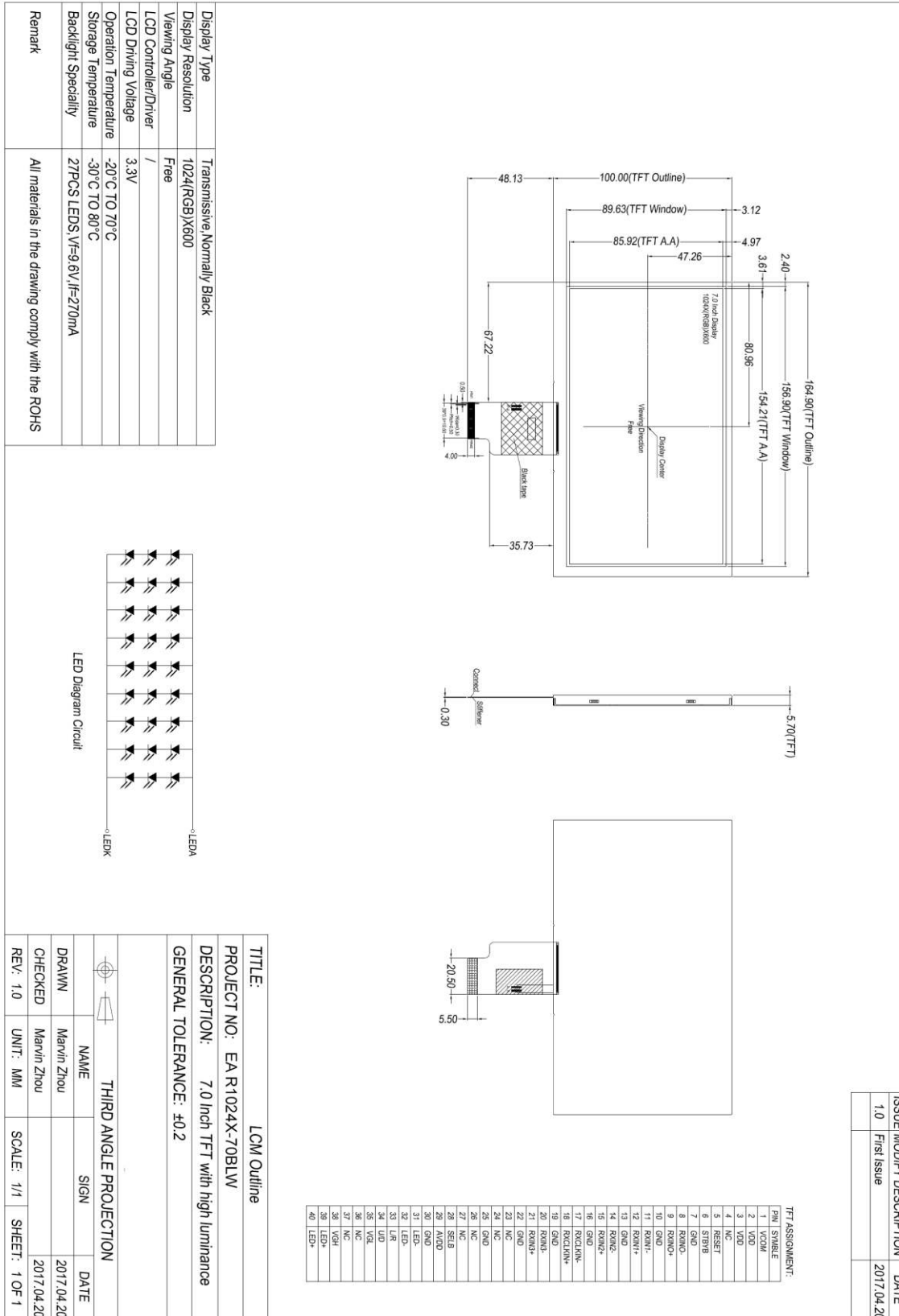

9.2 Outline Dimension EA R1024X-ALW (TFT incl. metal frame)

The EA R1024X-ALW is based on EA R1024X-BLW but comes together with a mounting frame (see C/Dwg below). It's made of black metal frame to mount the display onto a pcb.

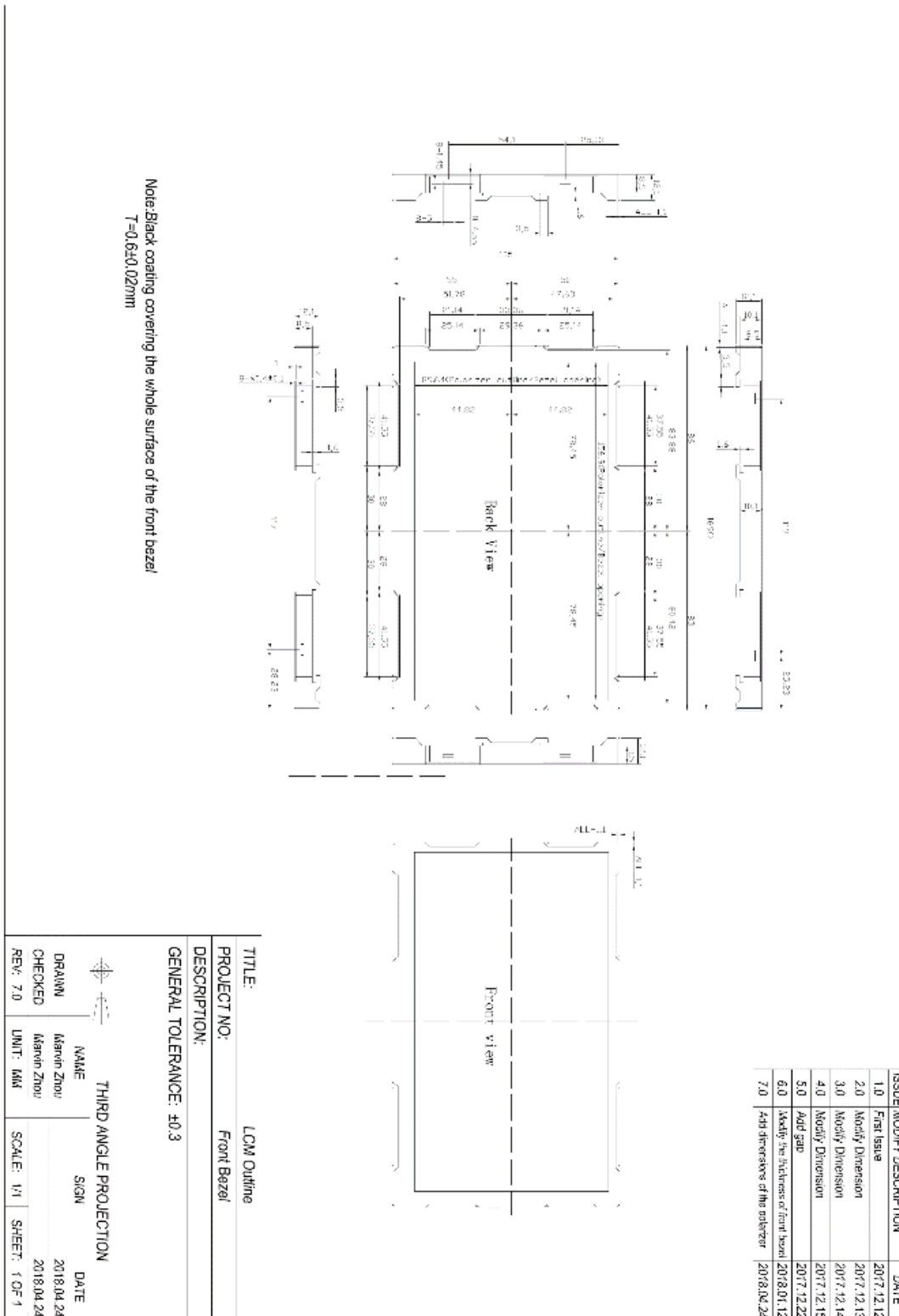

10. Reliability and Inspection Standard

No.	Test Item		Test Conditions	Remark
1	High Temperature	Storage	80°C, 120Hr	Note
		Operation	70°C, 120Hr	Note
2	Low Temperature	Storage	-30°C, 120Hr	Note
		Operation	-20°C, 120Hr	
3	High Temperature and High Humidity		40°C, 90%RH, 120Hr	Note
4	Peeling Off (Storage)		≥500gf/cm	Note
5	FPC Bending Test		≥6,000 times, 2/sec	Note
6	Vibration Test(Storage)		50HZ, 30min, Amplitude: 2 cm, X/Y/Z directions	Note
7	Drop Test		60cm/ 3Corner/ 8Face, 1Cycle	Note

Note:

- 1) The test samples should be applied to only one test item.
- 2) Sample size for each test item is 5~10pcs.
- 3) For Damp Proof Test, pure water(Resistance>1MΩ) should be used.
- 4) In case of malfunction defect caused by ESD damage, if it would be recovered to normal state after resetting, it would be judged as a good part.
- 5) EL evaluation should be excepted from reliability test with humidity and temperature: Some defects such as black spot/blemish can happen by natural chemical reaction with humidity and fluorescence EL has.
- 6) After the reliability test, the test samples should be inspected after 2 hours at least.
- 7) Functional test is OK. Missing segment, shorts, unclear segment, non display, display abnormally, liquid crystal leak are not allowed.
- 8) After testing, the current Idd should be within initial value ±20%.
- 9) No low temperature bubbles, end seal loose and fall, frame rainbow, ACF bubble growing are allowable in the appearance test.

11. PRECAUTIONS FOR USING LCD MODULES

Handling Precautions

- (1) The display panel is made of glass and polarizer. As glass is fragile, it tends to become or chipped during handling especially on the edges. Please avoid dropping or jarring. Do not subject it to a mechanical shock by dropping it or impact.
- (2) If the display panel is damaged and the liquid crystal substance leaks out, be sure not to get any in your mouth. If the substance contacts your skin or clothes, wash it off using soap and water.
- (3) Do not apply excessive force to the display surface or the adjoining areas since this may cause the color tone to vary. Do not touch the display with bare hands. This will stain the display area and degraded insulation between terminals (some cosmetics are determined to the polarizer).
- (4) The polarizer covering the display surface of the LCD module is soft and easily scratched. Handle this polarizer carefully. Do not touch, push or rub the exposed polarizers with anything harder than an HB pencil lead (glass, tweezers, etc.). Do not put or attach anything on the display area to avoid leaving marks on. Condensation on the surface and contact with terminals due to cold will damage, stain or dirty the polarizer. After products are tested at low temperature they must be warmed up in a container before coming in contact with room temperature air.
- (5) If the display surface becomes contaminated, breathe on the surface and gently wipe it with a soft dry cloth. If it is heavily contaminated, moisten cloth with one of the following solvents
 - Isopropyl alcohol
 - Ethyl alcoholDo not scrub hard to avoid damaging the display surface.
- (6) Solvents other than those above-mentioned may damage the polarizer. Especially, do not use the following.
 - Water
 - Ketone
 - Aromatic solventsWipe off saliva or water drops immediately, contact with water over a long period of time may cause deformation or color fading. Avoid contacting oil and fats.
- (7) Exercise care to minimize corrosion of the electrode. Corrosion of the electrodes is accelerated by water droplets, moisture condensation or a current flow in a high-humidity environment.
- (8) Install the LCD Module by using the mounting holes. When mounting the LCD module make sure it is free of twisting, warping and distortion. In particular, do not forcibly pull or bend the I/O cable or the backlight cable.
- (9) Do not attempt to disassemble or process the LCD module.
- (10) NC terminal should be open. Do not connect anything.
- (11) If the logic circuit power is off, do not apply the input signals.

- (12) Since LCM has been assembled and adjusted with a high degree of precision, avoid applying excessive shocks to the module or making any alterations or modifications to it.
- Do not alter, modify or change the shape of the tab on the metal frame.
 - Do not make extra holes on the printed circuit board, modify its shape or change the positions of components to be attached.
 - Do not damage or modify the pattern writing on the printed circuit board.
 - Absolutely do not modify the zebra rubber strip (conductive rubber) or heat seal connector.
 - Except for soldering the interface, do not make any alterations or modifications with a soldering iron.
 - Do not drop, bend or twist LCM.

Storage Precautions

When storing the LCD modules, the following precaution is necessary.

- (1) Store them in a sealed polyethylene bag. If properly sealed, there is no need for the dessicant.
- (2) Store them in a dark place. Do not expose to sunlight or fluorescent light, keep the temperature between 0°C and 35°C.
- (3) The polarizer surface should not come in contact with any other objects. (We advise you to store them in the container in which they were shipped).

Others

Liquid crystals solidify under low temperature (below the storage temperature range) leading to defective orientation or the generation of air bubbles (black or white). Air bubbles may also be generated if the module is subject to a low temperature.

If the LCD modules have been operating for a long time showing the same display patterns, the display patterns may remain on the screen as ghost images and a slight contrast irregularity may also appear. A normal operating status can be regained by suspending use for some time.

It should be noted that this phenomenon does not adversely affect performance reliability. To minimize the performance degradation of the LCD modules resulting from destruction caused by static electricity etc., exercise care to avoid holding the following sections when handling the modules.

- Exposed area of the printed circuit board.
- Terminal electrode sections.