

NOTES:

1. ELECTRICAL:

- VOLTAGE RATING PER IEC 60664: 300V
- VOLTAGE RATING PER UL: 300V
- CURRENT: 8A

2. TEMP RATING: -25° TO +60°C

3. PROTECTION: IP67 (WHEN MATED)

4. COUPLING THREAD" 7/8-16

5. AGENCY:

- UL RECOGNIZED, FILE: E152210
- CSA CERTIFICATION FILE: LR6837

6 ALL DIMS ARE FOR REFERENCE UNLES NOTED OTHERWISE

7. PART NUMBERS WITH "H" HAVE TWO ID MARKERS ONE ON EACH END

WIRING DIAGRAM

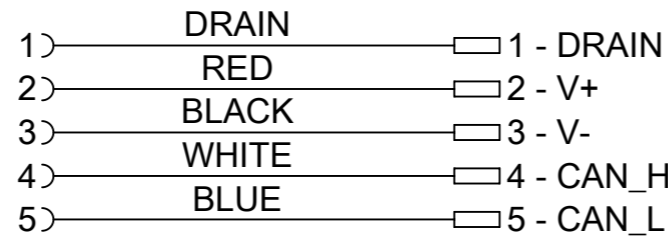

PART No. MATRIX

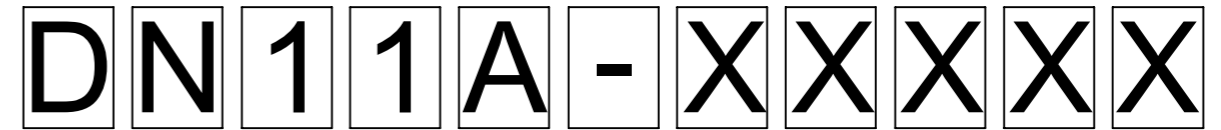

Units:
M = Meter
T= over
100 Meter

Length
Examples:
005 = 0.5 m
010 = 1 m
050 = 5 m
100 = 10 m
150 = 15 m

OPTIONAL:
H= ID CARRIER

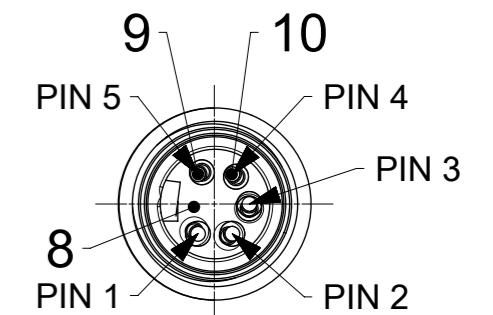
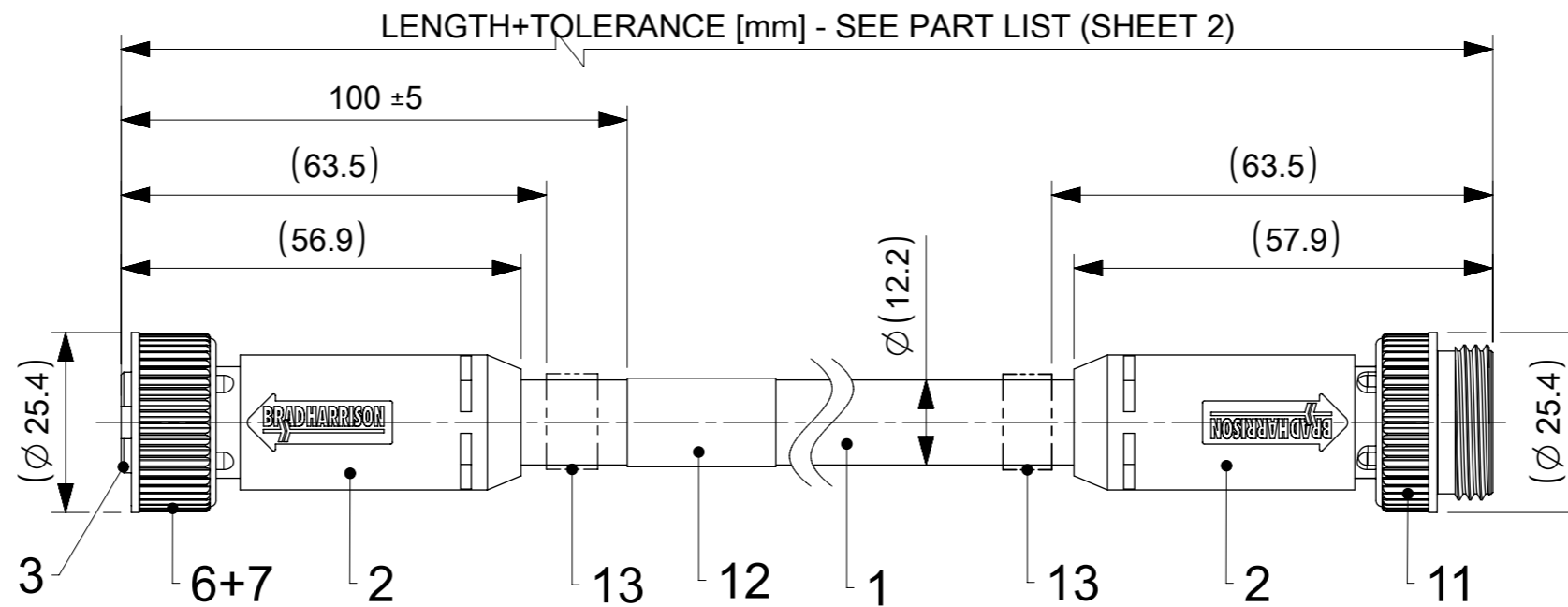
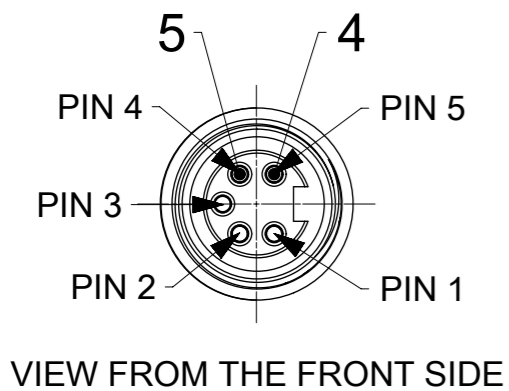

BILL OF MATERIALS

| ITEM | QTY | DESCRIPTION | MATERIAL | FINISH/COLOR |
|------|-----|------------------------------|----------|---------------------|
| 13 | 2 | ID CARRIER | PVC | - |
| 12 | 1 | LABEL WRAP | VINYL | YELLOW |
| 11 | 1 | COUPLING NUT A-SIZE EXT. | ZINC | BLACK |
| 10 | 2 | PIN CONTACT 16 AWG | COPPER | GOLD OVER Ni-PLATED |
| 9 | 3 | PIN CONTACT 18 AWG | COPPER | GOLD OVER Ni-PLATED |
| 8 | 1 | HOUSING A-SIZE 5P MALE | ARNITEL | BLACK |
| 7 | 1 | FRICTION RING A-SIZE | NYLON | GRAY |
| 6 | 1 | MC COUPLING NUT A-SIZE | ZINC | BLACK |
| 5 | 2 | MC SOCKET SLEEVE ASSY 16 AWG | COPPER | GOLD OVER Ni-PLATED |
| 4 | 3 | MC SOCKET SLEEVE ASSY 18 AWG | COPPER | GOLD OVER Ni-PLATED |
| 3 | 1 | HOUSING A-SIZE 5P FEMALE | ARNITEL | BLACK |
| 2 | - | MOULDING MATERIAL | ARNITEL | BLACK |
| 1 | - | TRUNK CABLE 19X30 AWG OD=12 | PVC | GRAY |
| ITEM | QTY | DESCRIPTION | MATERIAL | FINISH/COLOR |

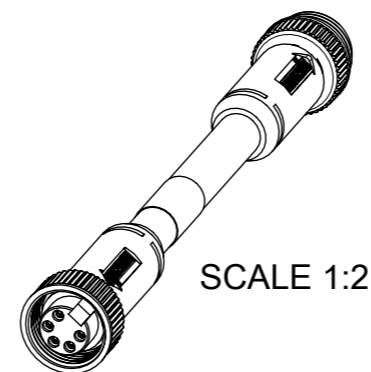

| | | | | |
|--|---|------------------------|--|---------------------|
| FUNCTIONAL SYMBOLS | THIS DRAWING CONTAINS INFORMATION THAT IS PROPRIETARY TO MOLEX ELECTRONIC TECHNOLOGIES, LLC AND SHOULD NOT BE USED WITHOUT WRITTEN PERMISSION | | CURRENT REV DESC: PIN'S ADDED, NOTES UPDATED | |
| | △/A = 0 | mm | SCALE | 1:1 |
| DIVISIONAL SYMBOLS | GENERAL TOLERANCES (UNLESS SPECIFIED) | | EC NO: 695738 | |
| | △/E = 0 | ANGULAR TOL | ± 1.0° | 2022/02/14 |
| FUNCTIONAL SYMBOLS | 4 PLACES | ± | DRWN: RSCHIEBER | 2022/02/15 |
| | 3 PLACES | ± | CHK'D: RSILLER | 2022/02/15 |
| | 2 PLACES | ± 0.05 | APPR: RSILLER | 2022/02/15 |
| | 1 PLACE | ± 0.3 | INITIAL REVISION: | |
| 0 PLACES | ± 0.5 | DRWN: MKOWALCZYK01 | 2018/09/07 | |
| DRAFT WHERE APPLICABLE MUST REMAIN WITHIN DIMENSIONS | | THIRD ANGLE PROJECTION | DRAWING | SERIES |
| | | | A3-SIZE | 130025 |
| DOCUMENT STATUS | | P1 | RELEASE DATE | 2022/02/15 09:19:21 |
| DOCUMENT NUMBER | | 1300250051 | | DOC TYPE |
| SEE SHEET 2 | | GENERAL MARKET | | DOC PART |
| | | | | REVISION |
| | | | | 000 B1 |
| | | | | SHEET NUMBER |
| | | | | 1 OF 2 |

