

GENERAL TOLERANCE										USED ON
10 MAX	30 MAX	50 MAX	70 MAX	100 MAX	120 MAX	250 MAX	250 OVER	ANGLE	ECCENT	
±0.15	±0.20	±0.30	±0.40	±0.50	±0.75	±0.90	±1.4	±0.5°	0.1	

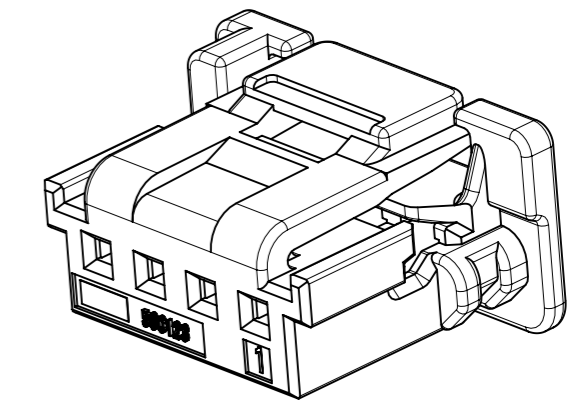

ISO VIEW

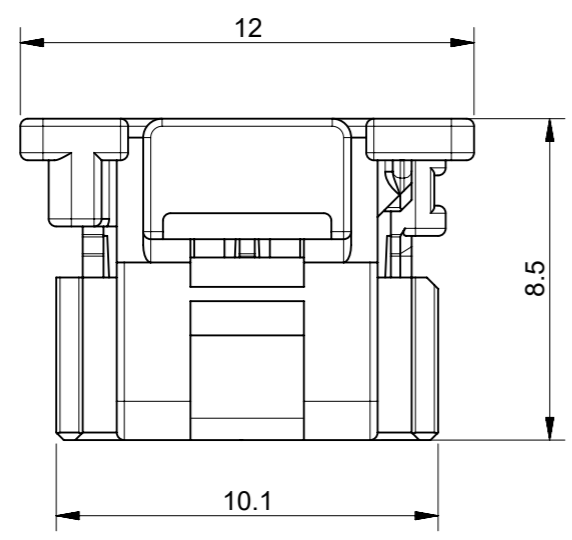
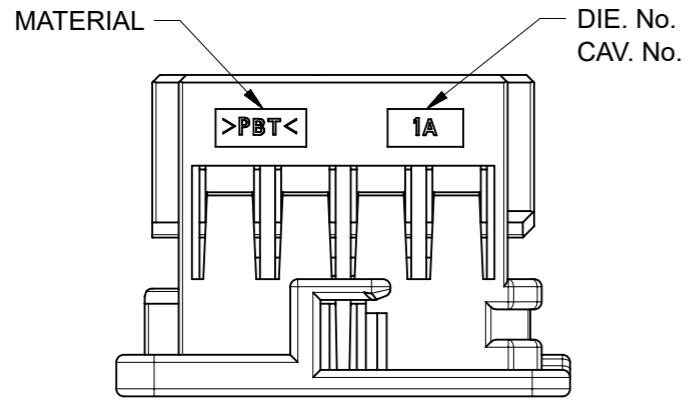
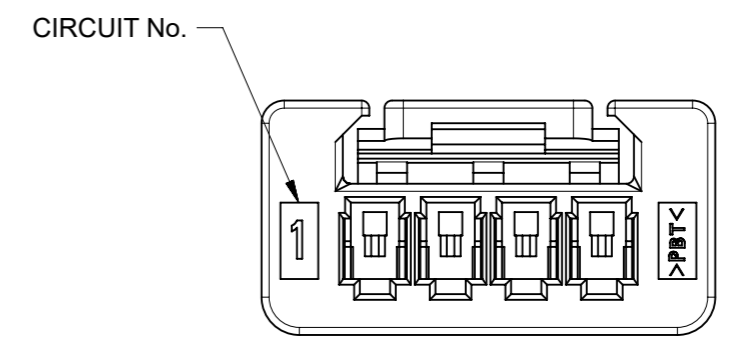
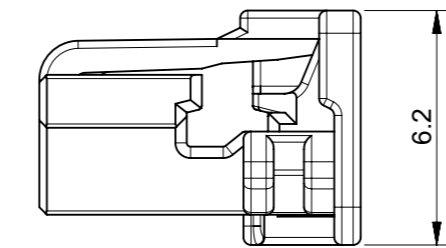
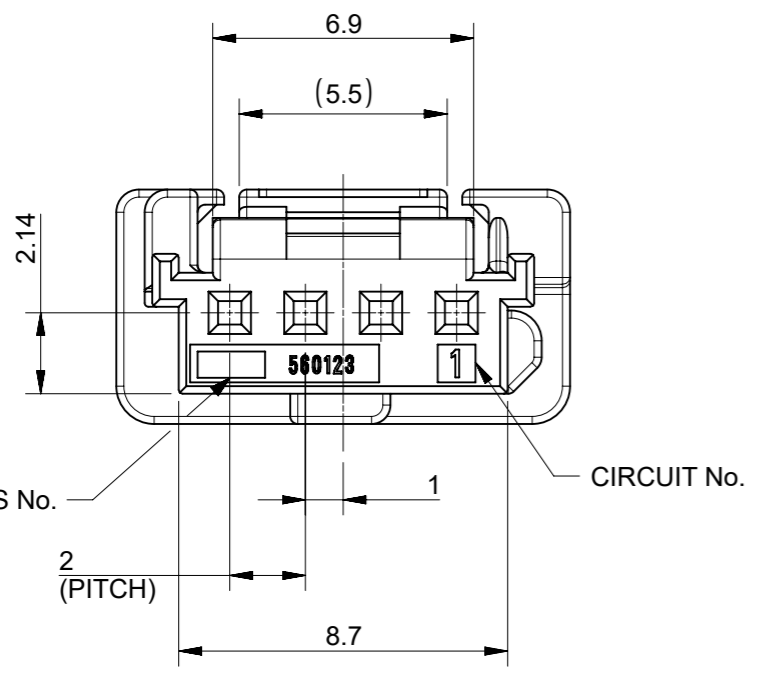

- NOTES:
1. MATERIALS : POLYESTER (PBT), GLASS UNFILLED, UL 94V-0
 2. MATE WITH : 502352, 560020 SERIES
 3. APPLICABLE TERMINAL : 560124 SERIES
 4. APPLICABLE ISL : 560125 SERIES
 5. GENERAL TOLERANCE : SEE TABLE
 6. EVL AND RoHS COMPLIANT
 7. PRODUCT SPECIFICATION : PS-560123-00*
 8. PACKING SPECIFICATION : PK-560123-001

MATERIAL NUMBER

ORDER NO.	MATERIAL NO.	COLOR
560123-0400	5601230400	WHITE
560123-0401	5601230401	BLACK
560123-0402	5601230402	RED
560123-0404	5601230404	BLUE

FUNCTIONAL SYMBOLS	THIS DRAWING CONTAINS INFORMATION THAT IS PROPRIETARY TO MOLEX ELECTRONIC TECHNOLOGIES, LLC AND SHOULD NOT BE USED WITHOUT WRITTEN PERMISSION		CURRENT REV DESC:		
	$\nabla/A = 0$ $\nabla/E = 0$ $\nabla/E = 0$	DIMENSION UNITS: mm SCALE: 5:1	EC NO: 668822 DRWN: SAKIM CHK'D: HIJIMA APPR: HIJIMA		
DIVISIONAL SYMBOLS	GENERAL TOLERANCES (UNLESS SPECIFIED)		INITIAL REVISION:		DOCUMENT NUMBER: SD-560123-002 DOC TYPE: PSD DOC PART: 001 REVISION: C3
	ANGULAR TOL ± ° 4 PLACES ± 3 PLACES ± 2 PLACES ± 1 PLACE ± 0 PLACES ±		DRWN: YIBAEK APPR: SRTAK 2014/07/03 2014/08/26		
DRAFT WHERE APPLICABLE MUST REMAIN WITHIN DIMENSIONS		THIRD ANGLE PROJECTION	DRAWING: A3-SIZE	SERIES: 560123	MATERIAL NUMBER: SEE TABLE
			CUSTOMER: GENERAL MARKET		SHEET NUMBER: 1 OF 1