

FPP06R001

75V/60A Synchronous Rectifier Module

General Features

- Very High Rectification Efficiency at Output 12V
- Integrated Solution for Saving Board Space
- Improved Driving Capability with Prominent Internal Driver IC
- RoHS Compliant



Sync-Rectifier Switch Features

- $R_{DS(ON)} = 3.5m\Omega(Typ.)$, $V_{IN} = 10V$, $I_D = 40A$
- Low Miller Charge
- Low Q_{rr} Body Diode
- UIS Capability (Single Pulse and Repetitive Pulse)

Driver IC Features

- 2.5A Max Current Driving Capability
- Low Propagation Delay Time
- Optimized for Increasing Driving Capability Using General Low-Current Gate Driver with a Minimum Delay Time

General Description

The FPP06R001 is one product in the Power-SPM™ family that Fairchild has newly developed and designed to be most suitable for more compact and more efficient synchronous rectification applications such as internet server power supplies and telecom system power supplies. For higher efficiency, it includes built-in very low $R_{DS(ON)}$ MOSFETs. In addition, it includes the superior gate driver that supports higher driving capability to be more suitable for these low $R_{DS(ON)}$ MOSFETs. This Power-SPM device can be used in the secondary side of the PWM transformer of forward/bridge converter to provide high current rectification at output voltages ranging from 12 Volts down to 5 Volts. With this product, it is possible to design the secondary side of power supply systems with reduced parasitic elements resulting in minimized voltage spike and EMI noise.

Applications

- High Current Isolated Converter
- Distributed Power Architectures

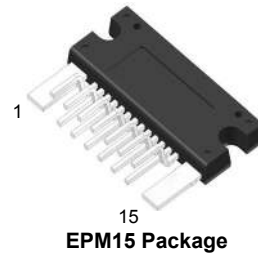

Block Diagram

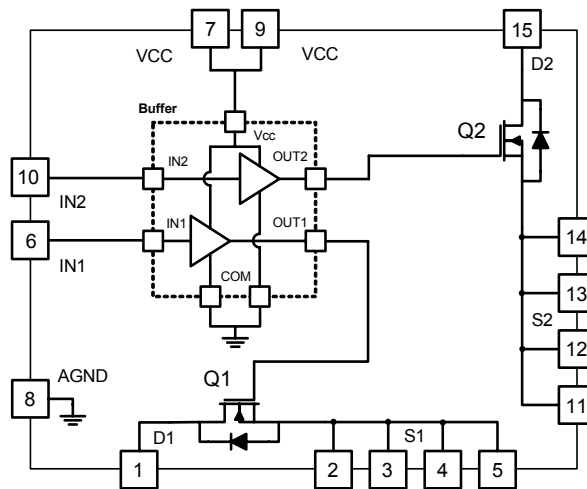

Figure 1. FPP06R001 Module Block Diagram

Pin Configuration and Pin Description

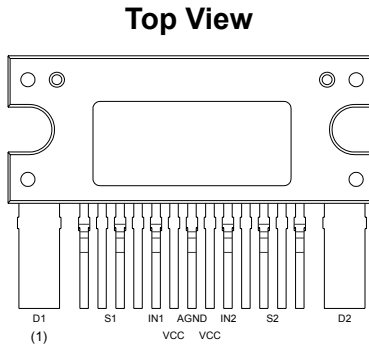

Figure 2. Pinmap of FPP06R001

Pin Number	Pin Name	Pin Description
1	D1	Drain of Q1, MOSFET
2 ~ 5	S1	Source of Q1, MOSFET
6	IN1	Input signal for Q1, MOSFET
7	VCC	Supply voltage for Driver IC
8	AGND	Analog ground
9	VCC	Supply voltage for Driver IC
10	IN2	Input signal for Q2, MOSFET
11 ~ 14	S2	Source of Q2, MOSFET
15	D2	Drain of Q2, MOSFET

Absolute Maximum Ratings $T_C = 25^\circ\text{C}$, Unless Otherwise Specified

Symbol	Parameter	Rating	Unit
V_{DS}	Drain to Source Voltage (Note1)	75	V
V_{IN}	Input Voltage	$V_{CC} + 0.3$	V
I_D	Drain Current, Continuous ($V_{IN} = 10V$) (Note1)	60	A
E_{AS}	Single Pulse Avalanche Energy (Note1,2)	681	mJ
V_{CC}	Driver IC Supply Voltage	20	V
T_J, T_{STG}	Operating and Storage Temperature Range	-40 ~ 125	$^\circ\text{C}$

Thermal Resistance

Symbol	Parameter	Min.	Typ.	Max.	Unit
$R_{\theta JC}$	Junction to Case Thermal Resistance (Note1)	-	-	3.9	$^\circ\text{C}/\text{W}$

Note:

1. Each MOSFET Switch
2. Starting $T_J = 25^\circ\text{C}$, $V_D = 40V$, $L = 0.2\text{mH}$, $I_{AS} = 56.4A$

Electrical Characteristics $T_C = 25^\circ\text{C}$, Unless Otherwise Specified

Symbol	Parameter	Test Conditions	Min.	Typ.	Max.	Units
--------	-----------	-----------------	------	------	------	-------

Sync-Rectifier Switch Part (Each Switch)

BV_{DSS}	Drain to Source Breakdown Voltage	$I_D = 250\mu\text{A}$, $V_{IN} = 0\text{V}$ Source is connected to AGND	75	-	-	V	
I_{DSS}	Zero IN Voltage Drain Current	$V_{IN} = 0\text{V}$, $V_{DS} = 60\text{V}$ Source is connected to AGND	-	-	1	μA	
$V_{IN(TH)}$	IN Threshold Voltage	$V_{CC} = 15\text{V}$, $V_D = 20\text{V}$, $I_{DS} = 250\mu\text{A}$ Source is connected to AGND	2.5	-	4.5	V	
$R_{DS(ON)}$	Drain to Source On Resistance	$V_{CC} = 15\text{V}$, $I_D = 40\text{A}$, $V_{IN} = 10\text{V}$ Source is connected to AGND	$T_J = 25^\circ\text{C}$	-	3.5	4.3	m Ω
			$T_J = 125^\circ\text{C}$	-	6.3	-	
V_{SD}	Source to Drain Diode Voltage	$I_{SD} = 80\text{A}$ $I_{SD} = 40\text{A}$	-	-	1.25	V	
			-	-	1.0		
t_{rr}	Reverse Recovery Time	$I_{SD} = 40\text{A}$, $dI_{SD}/dt = 100\text{A}/\mu\text{s}$	-	42	-	ns	
Q_{rr}	Reverse Recovery Charge	$I_{SD} = 40\text{A}$, $dI_{SD}/dt = 100\text{A}/\mu\text{s}$	-	62	-	nC	

Driver IC Part

V_{CC}	Supply Voltage		5	-	20	V
I_{SOURCE}	Peak Output Source Current	$V_{CC} = 15\text{V}$	-	-	-2.5	A
I_{SINK}	Peak Output Sink Current	$V_{OUT} = 15\text{V}$	2.5	-	-	A
V_{OH}	Output Voltage High	$V_{CC} = V_{IN} = 15\text{V}$	14.0	-	-	V
V_{OL}	Output Voltage Low	$V_{CC} = 15\text{V}$, $V_{IN} = 0\text{V}$	-	-	1.0	V
R_{ON}	Turn-on Output Resistance		-	5	-	Ω
R_{OFF}	Turn-off Output Resistance		-	0	-	Ω
I_{QCC}	Quiescent Supply Current	$V_{CC} = 20\text{V}$, $V_{IN} = 0\text{V}$	-	-	2	μA
R_{LIN}	Input Pull-down Resistance		-	50	-	k Ω
R_{LOUT}	Output Pull-down Resistance		-	10	-	k Ω
$td1$	Output Turn-On Propagation Delay	$f_{IN} = 20\text{kHz}$	-	-	20	ns
$td2$	Output Turn-Off Propagation Delay	$f_{IN} = 20\text{kHz}$	-	-	20	ns

Switching Time

t_{ON}	Turn-On Time	$V_{CC} = 15\text{V}$, $I_D = 40\text{A}$ $V_{IN} = 10\text{V}$, $V_{DD} = 40\text{V}$, $R_{IN} = 5\Omega$ (Note3)	-	-	100	ns
$t_{d(on)}$	Turn-On Delay Time		-	25	-	ns
t_r	Rise Time		-	40	-	ns
$t_{d(off)}$	Turn-Off Delay Time		-	50	-	ns
t_f	Fall Time		-	22	-	ns
t_{OFF}	Turn-Off Time		-	-	115	ns

Note:

3. t_{ON} and t_{OFF} include the propagation delay time of the internal driver IC. For the detailed information, please see Figure 14.

Typical Performance Characteristics 1. Each Switch, 2. $V_{CC} = 15V$, Unless Otherwise Specified

Figure 3. On-Region Characteristics

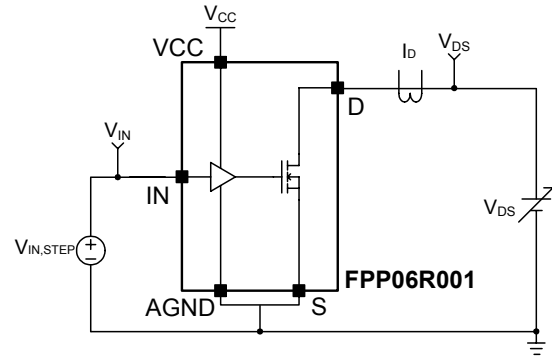
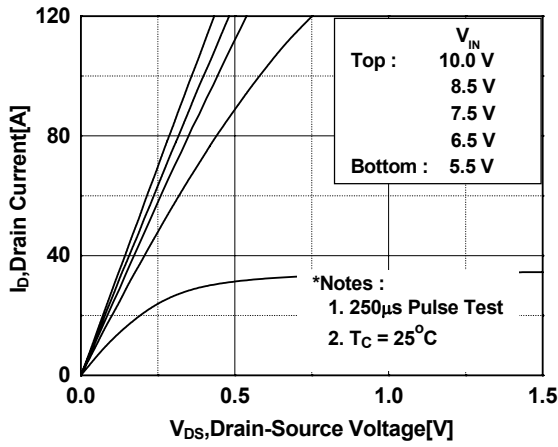

Figure 4. Transfer Characteristics

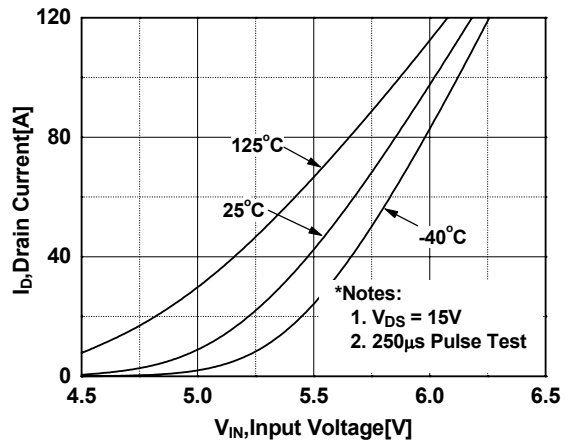
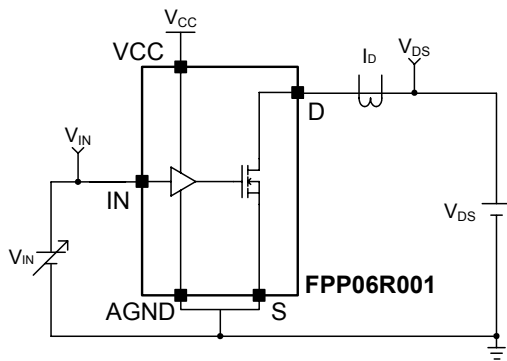

Figure 5. Body Diode Forward Voltage Variation vs. Source Current and Temperature

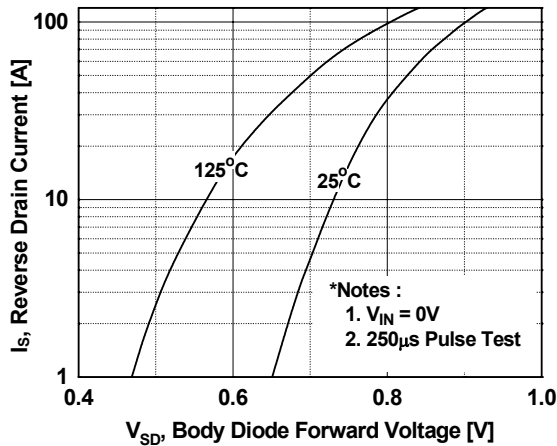
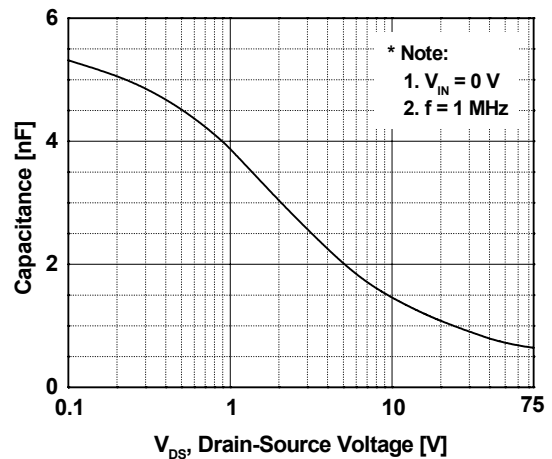

Figure 6. Output Capacitance Characteristic



Typical Performance Characteristics (Continued)

Figure 7. Breakdown Voltage Variation vs. Temperature

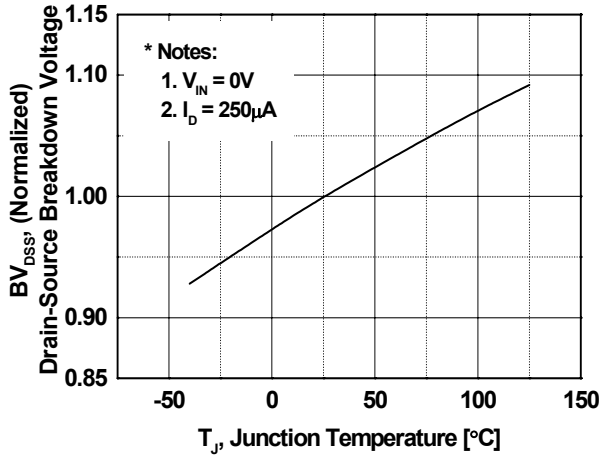

Figure 8. On-Resistance Variation vs. Temperature

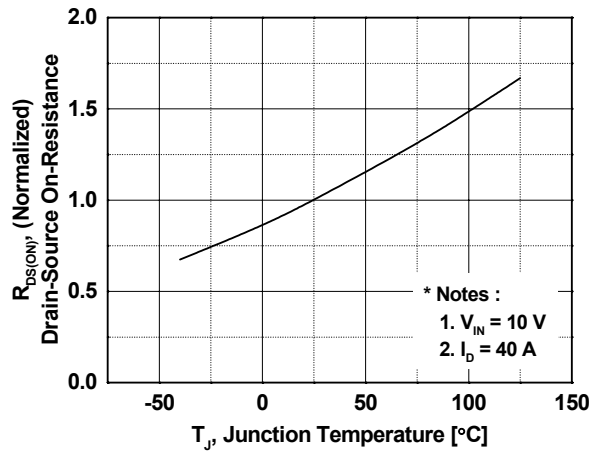

Figure 9. Transient Thermal Response Curve

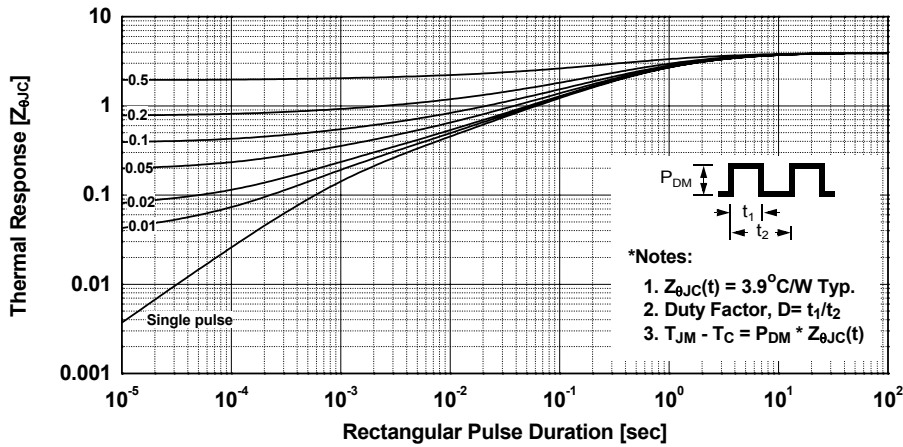

Figure 10. Maximum Safe Operating Area

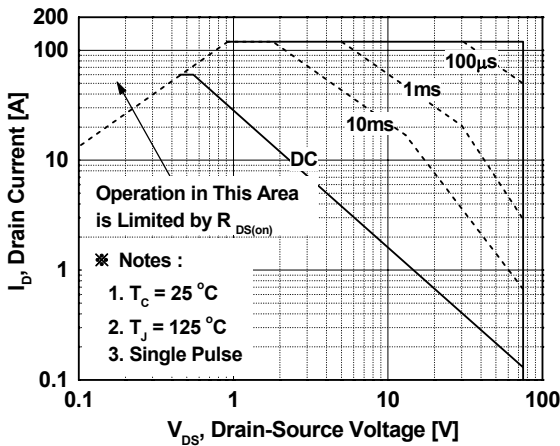
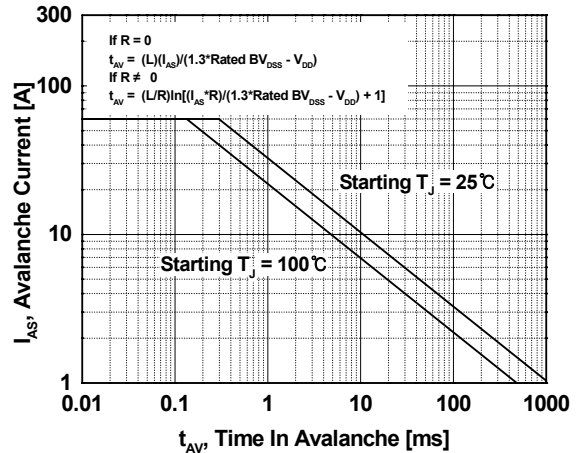

Figure 11. Unclamped Inductive Switching Capability



AC Test Circuits and Waveforms

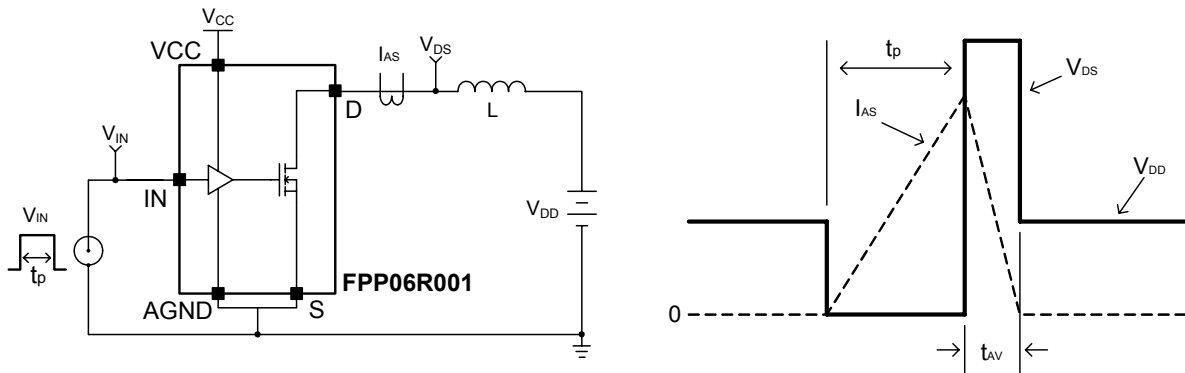

Figure 12. Unclamped Inductive Switching Test Circuit and Waveforms

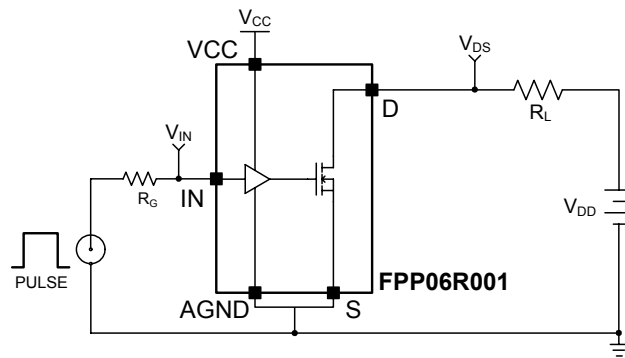

Figure 13. Switching Test Circuit

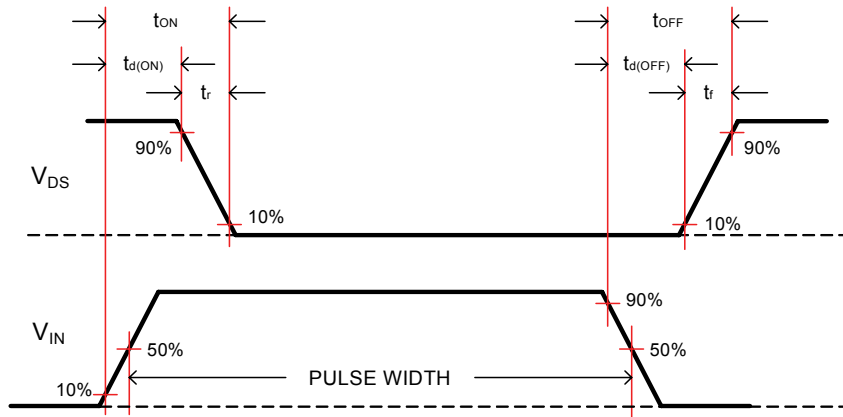

Figure 14. Switching Test Waveforms

Application circuits

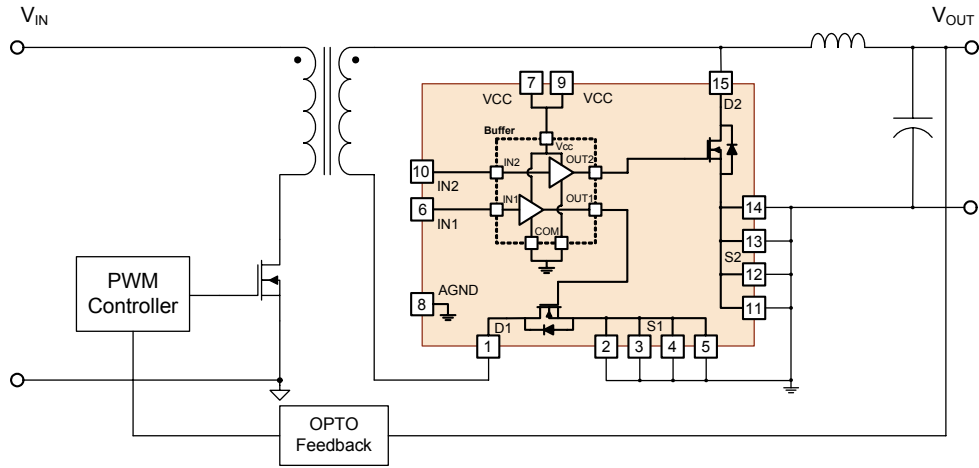

Figure 15. Application Circuit of Forward Converter with FPP06R001

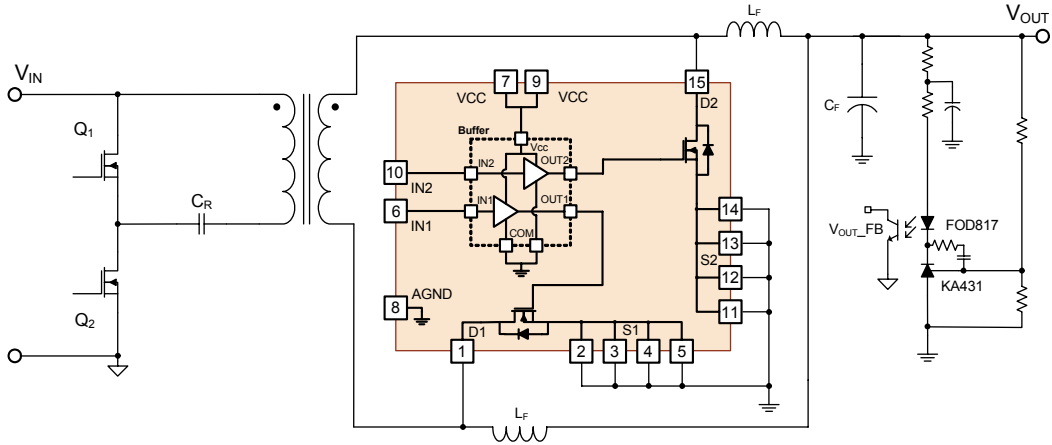

Figure 16. Application Circuit of Asymmetrical HB Converter with FPP06R001

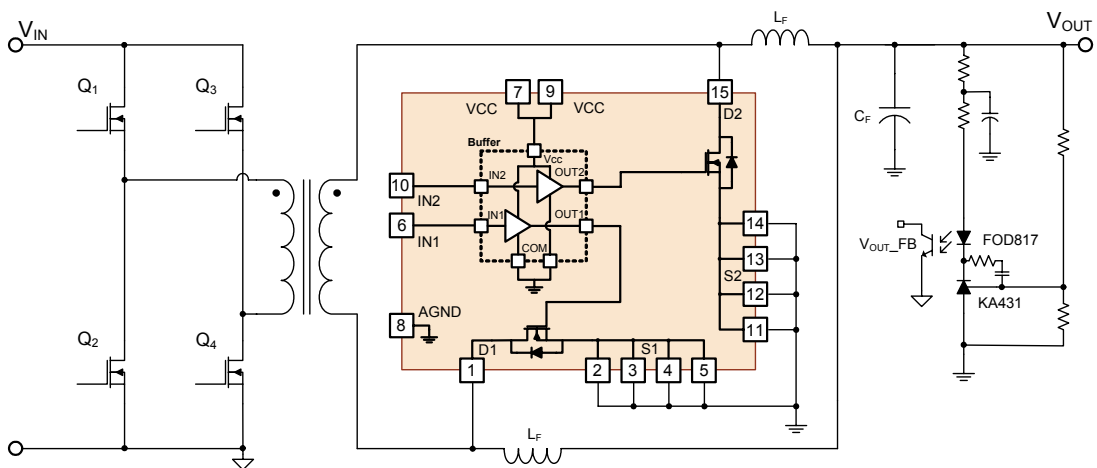

Figure 17. Application Circuit of Full Bridge Converter with FPP06R001

Detailed Package Outline Drawings

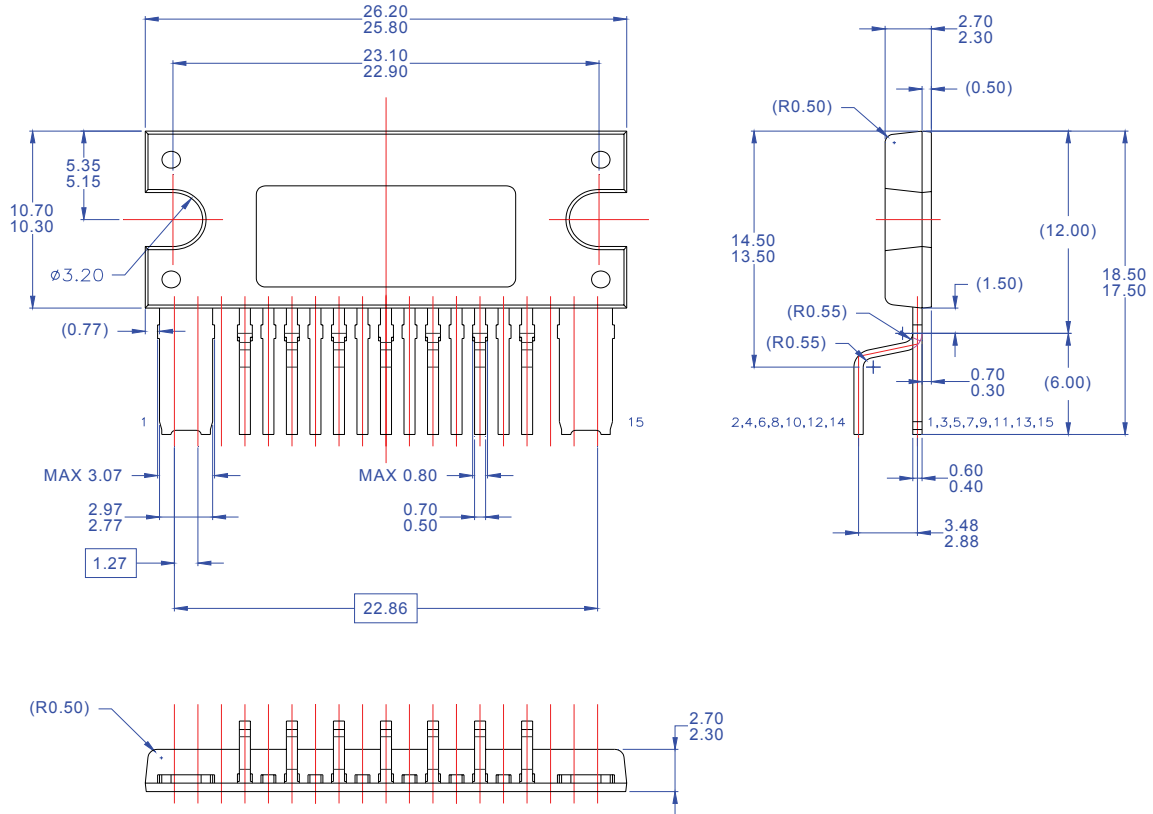

Figure 18. EPM15 Package

Dimensions in Millimeters



TRADEMARKS

The following are registered and unregistered trademarks and service marks Fairchild Semiconductor owns or is authorized to use and is not intended to be an exhaustive list of all such trademarks.

- | | | | |
|--------------------------------------|--|--|----------------------------------|
| ACEx [®] | FPS [™] | PDP-SPM [™] | SyncFET [™] |
| Build it Now [™] | FRFET [®] | Power220 [®] | SYSTEM GENERAL [®] |
| CorePLUS [™] | Global Power Resource SM | Power247 [®] | The Power Franchise [®] |
| CROSSVOLT [™] | Green FPS [™] | POWEREDGE [®] | the power franchise |
| CTL [™] | Green FPS [™] e-Series [™] | Power-SPM [™] | TinyBoost [™] |
| Current Transfer Logic [™] | GTO [™] | PowerTrench [®] | TinyBuck [™] |
| EcoSPARK [®] | <i>i-Lo</i> [™] | Programmable Active Droop [™] | TinyLogic [®] |
| EZSWITCH [™] * | IntelliMAX [™] | QFET [®] | TINYOPTO [™] |
| EZ [™] | ISOPLANAR [™] | QS [™] | TinyPower [™] |
| F [®] | MegaBuck [™] | QT Optoelectronics [™] | TinyPWM [™] |
| Fairchild [®] | MICROCOUPLER [™] | Quiet Series [™] | TinyWire [™] |
| Fairchild Semiconductor [®] | MicroFET [™] | RapidConfigure [™] | μSerDes [™] |
| FACT Quiet Series [™] | MicroPak [™] | SMART START [™] | UHC [®] |
| FACT [®] | MillerDrive [™] | SPM [®] | Ultra FRFET [™] |
| FAST [®] | Motion-SPM [™] | STEALTH [™] | UniFET [™] |
| FastvCore [™] | OPTOLOGIC [®] | SuperFET [™] | VCX [™] |
| FlashWriter [®] * | OPTOPLANAR [®] | SuperSOT [™] -3 | |
| | [®] | SuperSOT [™] -6 | |
| | | SuperSOT [™] -8 | |

* EZSWITCH[™] and FlashWriter[®] are trademarks of System General Corporation, used under license by Fairchild Semiconductor.

DISCLAIMER

FAIRCHILD SEMICONDUCTOR RESERVES THE RIGHT TO MAKE CHANGES WITHOUT NOTICE TO ANY PRODUCTS HEREIN TO IMPROVE RELIABILITY, FUNCTION, OR DESIGN. FAIRCHILD DOES NOT ASSUME ANY LIABILITY ARISING OUT OF THE APPLICATION OR USE OF ANY PRODUCT OR CIRCUIT DESCRIBED HEREIN; NEITHER DOES IT CONVEY ANY LICENSE UNDER ITS PATENT RIGHTS, NOR THE RIGHTS OF OTHERS. THESE SPECIFICATIONS DO NOT EXPAND THE TERMS OF FAIRCHILD'S WORLDWIDE TERMS AND CONDITIONS, SPECIFICALLY THE WARRANTY THEREIN, WHICH COVERS THESE PRODUCTS.

LIFE SUPPORT POLICY

FAIRCHILD'S PRODUCTS ARE NOT AUTHORIZED FOR USE AS CRITICAL COMPONENTS IN LIFE SUPPORT DEVICES OR SYSTEMS WITHOUT THE EXPRESS WRITTEN APPROVAL OF FAIRCHILD SEMICONDUCTOR CORPORATION.

As used herein:

1. Life support devices or systems are devices or systems which, (a) are intended for surgical implant into the body, or (b) support or sustain life, and (c) whose failure to perform when properly used in accordance with instructions for use provided in the labeling, can be reasonably expected to result in significant injury to the user.
2. A critical component is any component of a life support device or system whose failure to perform can be reasonably expected to cause the failure of the life support device or system, or to affect its safety or effectiveness.

PRODUCT STATUS DEFINITIONS

Definition of Terms

Datasheet Identification	Product Status	Definition
Advance Information	Formative or In Design	This datasheet contains the design specifications for product development. Specifications may change in any manner without notice.
Preliminary	First Production	This datasheet contains preliminary data; supplementary data will be published at a later date. Fairchild Semiconductor reserves the right to make changes at any time without notice to improve design.
No Identification Needed	Full Production	This datasheet contains final specifications. Fairchild Semiconductor reserves the right to make changes at any time without notice to improve design.
Obsolete	Not In Production	This datasheet contains specifications on a product that has been discontinued by Fairchild semiconductor. The datasheet is printed for reference information only.

Rev. I32