

THIS DRAWING IS UNPUBLISHED. RELEASED FOR PUBLICATION 20  
 © COPYRIGHT 20 BY - ALL RIGHTS RESERVED.

LOC		DIST		REVISIONS			
P	LTR	DESCRIPTION		DATE	DWN	APVD	
DY	-	B	REVISED ECR-19-007126	28 MAY 2019	E.Z	W.H	

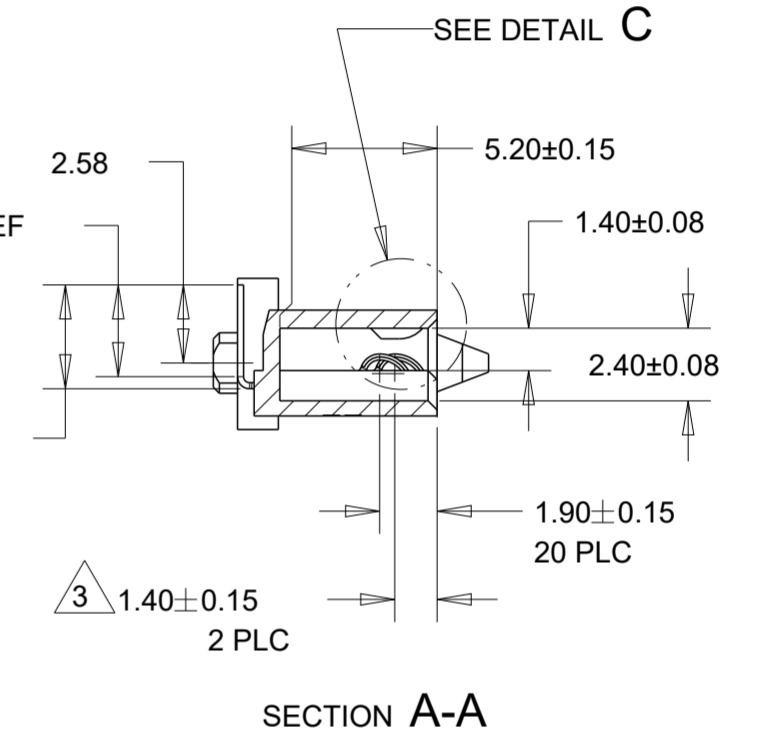
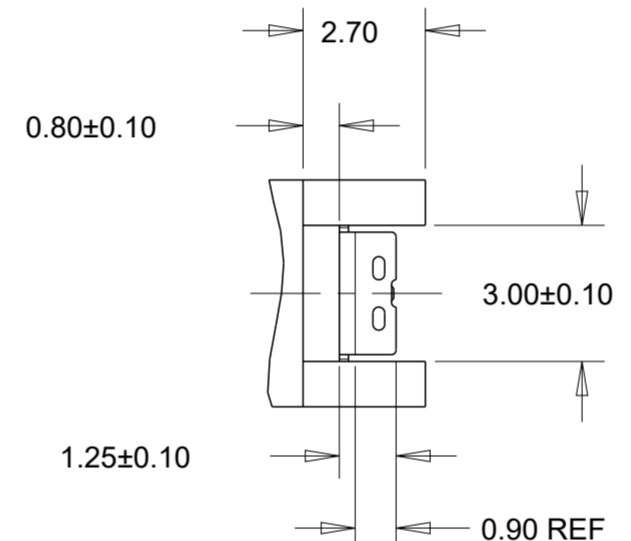
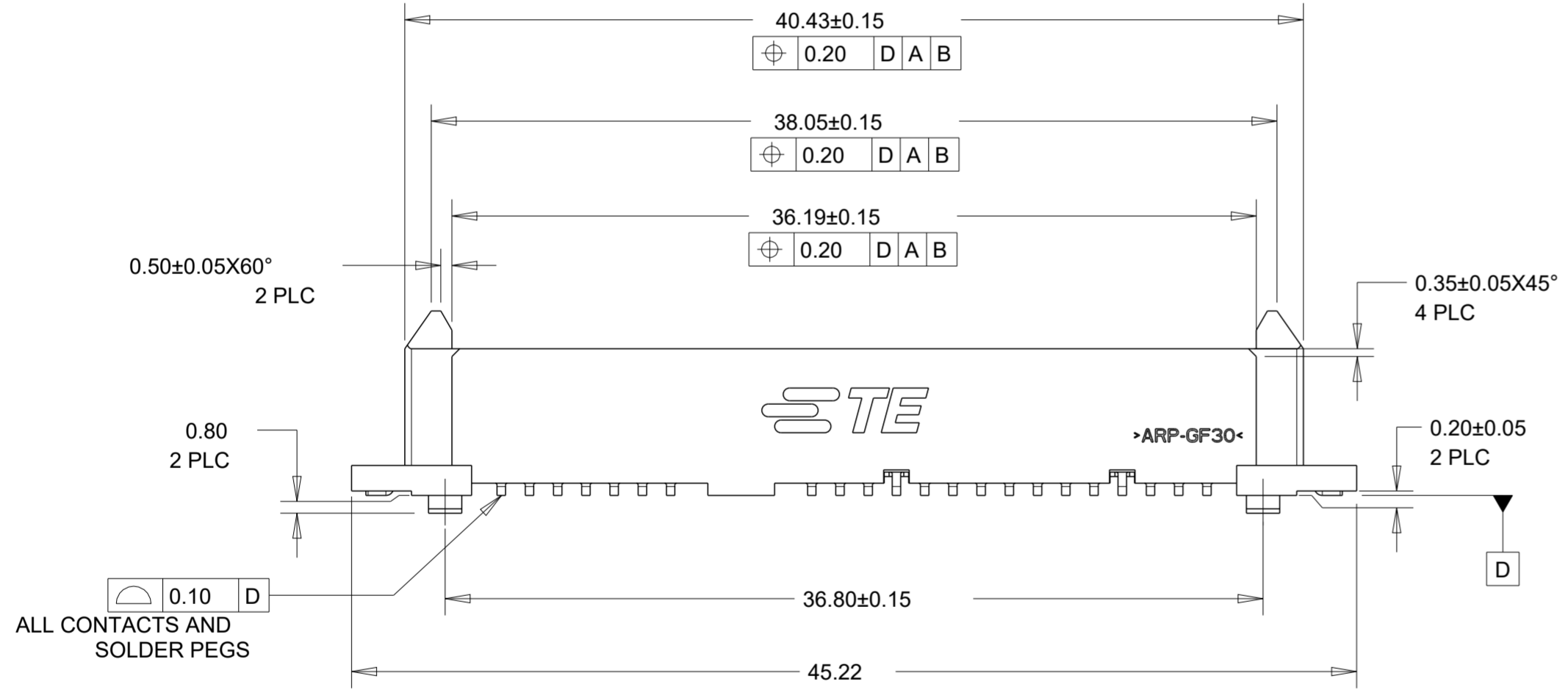
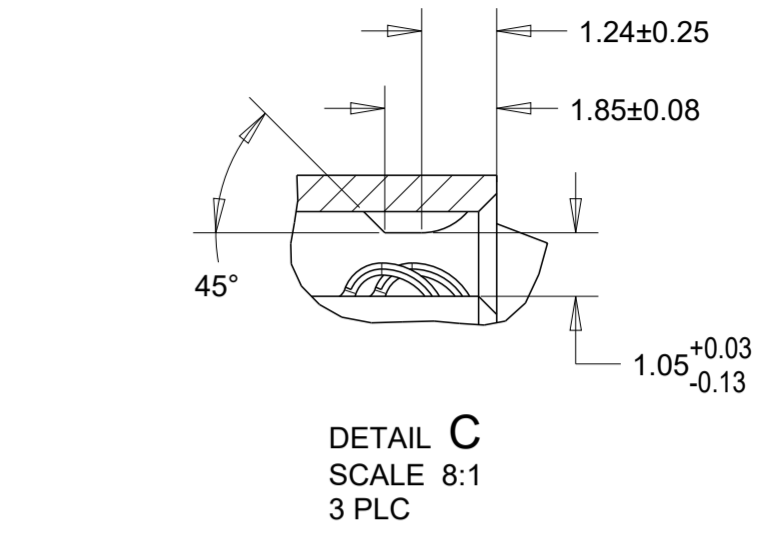
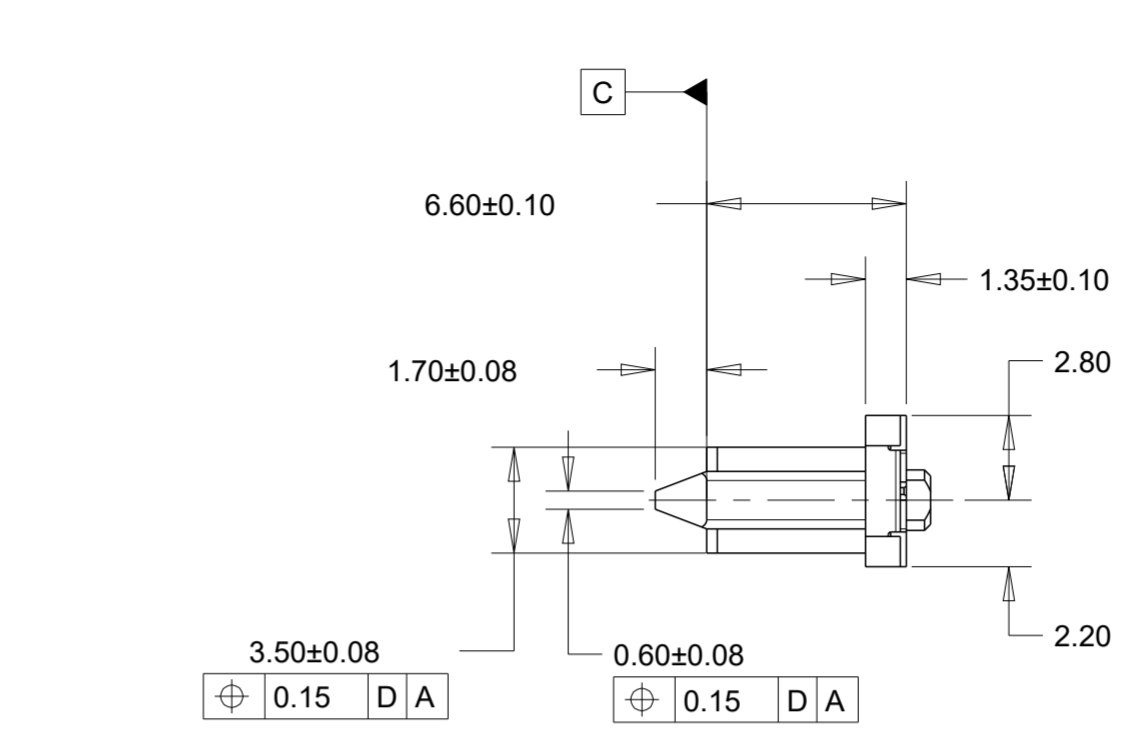
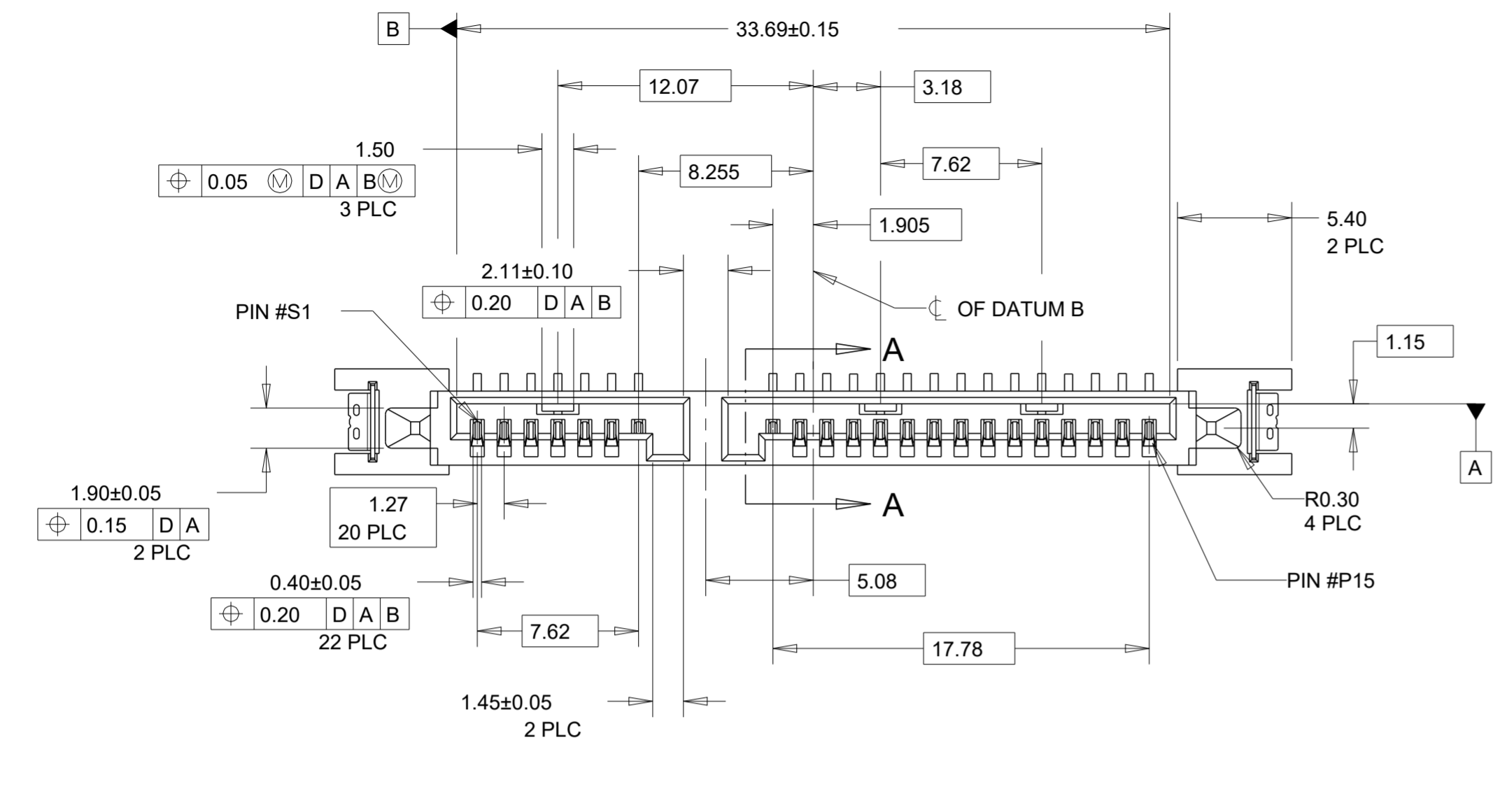

NOTES:

- 1 MATERIAL:  
 HOUSING: HIGH TEMP THERMOPLASTIC, UL94V-0, BLACK  
 PICK-UP CAP: HIGH TEMP THERMOPLASTIC, UL94V-0, NATURE  
 CONTACT: COPPER ALLOY  
 SOLDER PEG: COPPER ALLOY
- 2 FINISH:  
 CONTACT MATING AREA: GOLD FLASH PLATING  
 CONTACT SOLDER TAIL: GOLD FLASH PLATING  
 SOLDER PEG: MIN 2.54um MATTE TIN PLATING  
 UNDERPLATE: MIN 1.27um NICKEL PLATING
- 3 PIN #P4 AND #P12 ONLY
- 4 DATECODE (YWW) COLD STAMPED AT APPROXIMATE LOCATION
- 5. PACKAGING: TAPE & REEL. QTY/REEL: 280PCS

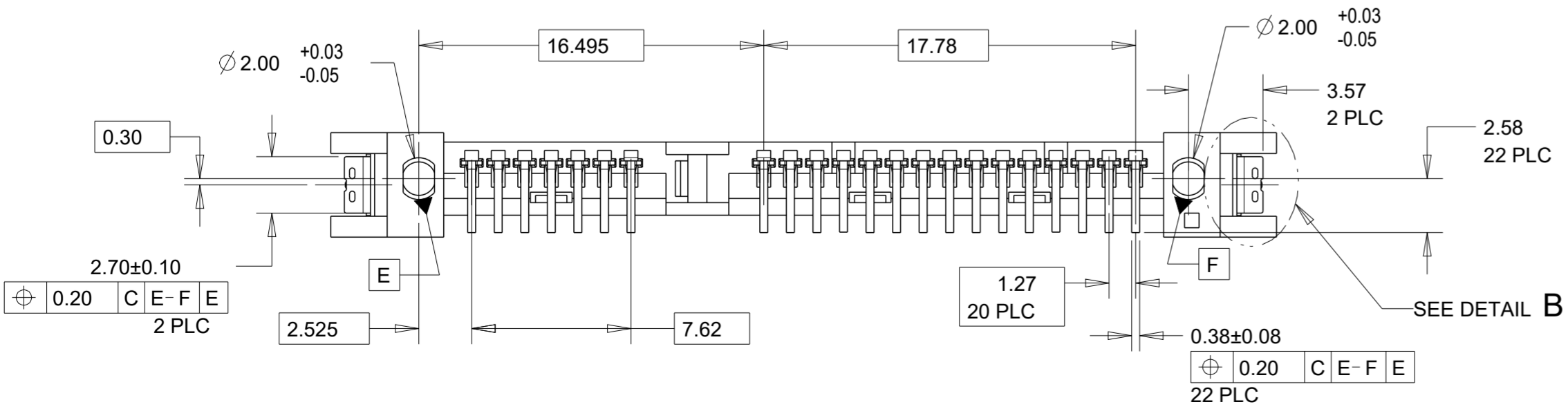

AS SHOWN WITHOUT PICK-UP CAP

NO	1735944-2
YES	1735944-1
PICK-UP CAP	PART NUMBER

THIS DRAWING IS A CONTROLLED DOCUMENT.		DWN SK LEAW 28JUL2011	TE Connectivity Singapore	
DIMENSIONS: mm		CHK SF LEONG 19SEP2011		
TOLERANCES UNLESS OTHERWISE SPECIFIED:		APVD SF LEONG 19SEP2011	NAME	
0 PLC ±	1 PLC ±	PRODUCT SPEC	SATA BACKPLANE RECEPTACLE, VERTICAL, SMT LOW PROFILE	
2 PLC ±0.20	3 PLC ±	APPLICATION SPEC	SIZE	CAGE CODE
4 PLC ±	ANGLES ±3°	WEIGHT	A2	00779
FINISH		CUSTOMER DRAWING	DRAWING NO	RESTRICTED TO
1	2	SCALE 4:1	C-1735944	
			SHEET 1 OF 2	REV B

THIS DRAWING IS UNPUBLISHED. RELEASED FOR PUBLICATION 20  
 © COPYRIGHT 20 BY - ALL RIGHTS RESERVED.

LOC		DIST		REVISIONS			
P	LTR	DESCRIPTION	DATE	DWN	APVD		
DY	-	SEE SHEET 1	-	-	-		

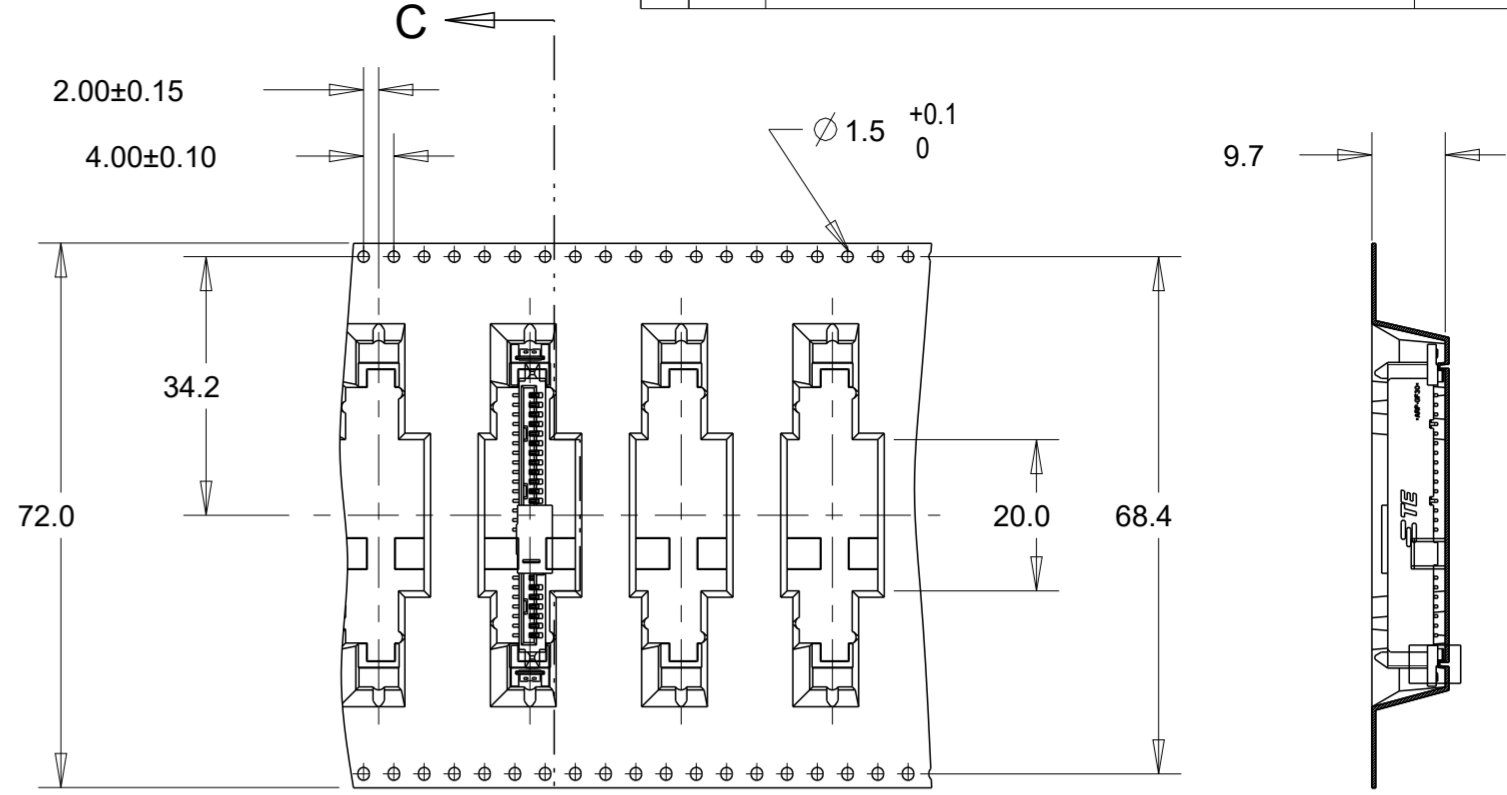
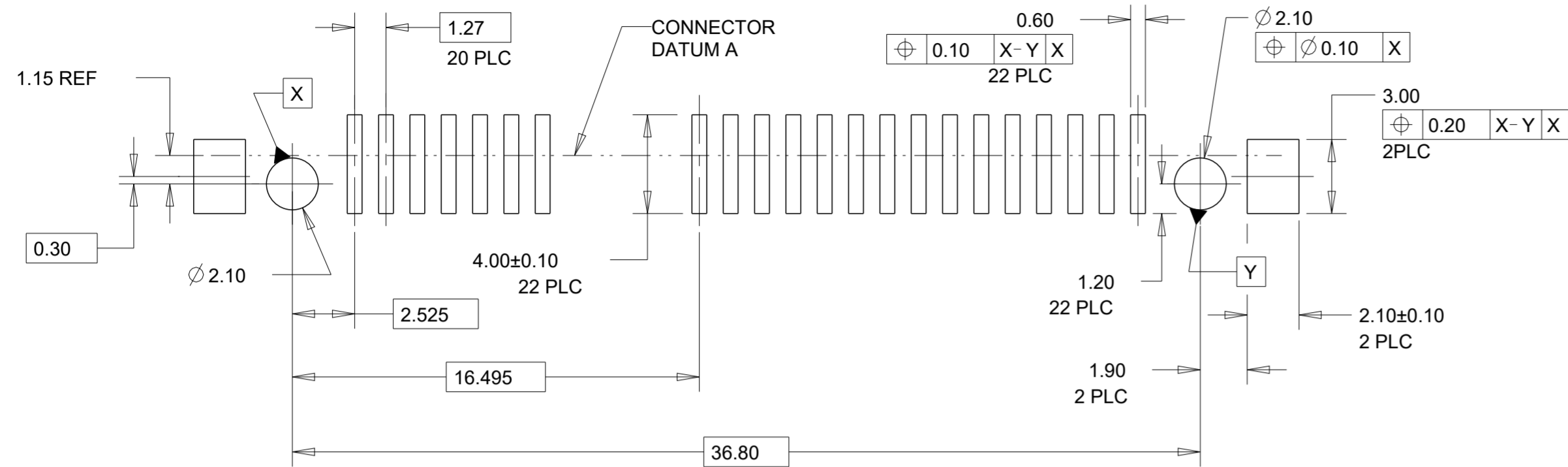

RECOMMENDED PCB LAYOUT  
 GENERAL TOLERANCE ± 0.05  
 SCALE 5:1

SECTION C-C

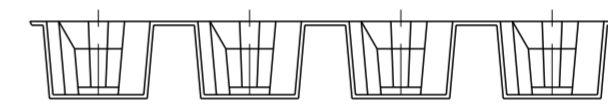
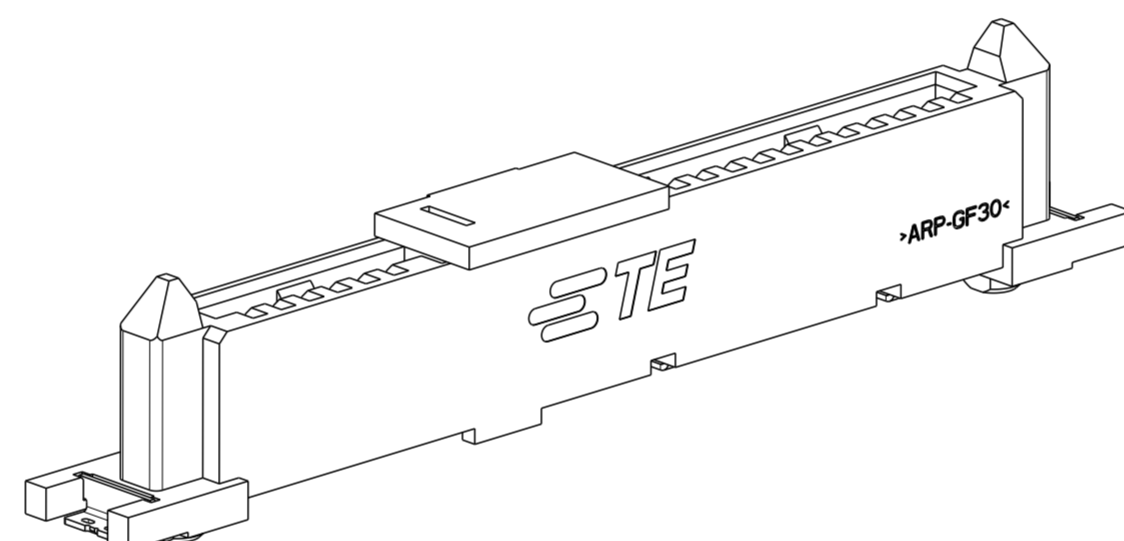

SCALE 1:1

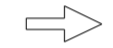

CUSTOMER DE-REEL DIRECTION

MATING X-SECTION WITH HDD

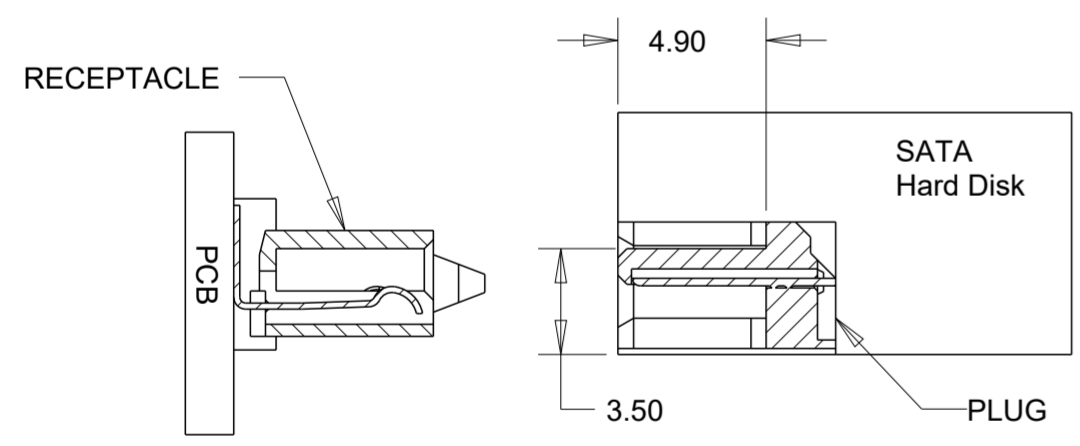

BEFORE MATING

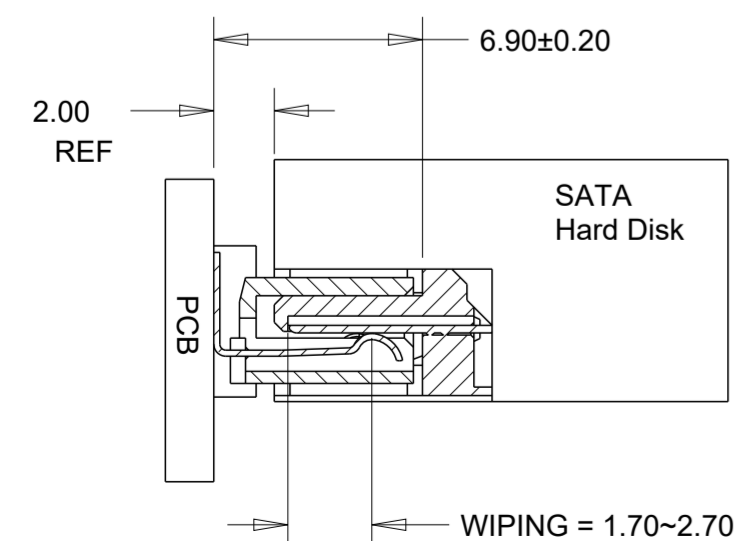

AFTER MATING

AS SHOWN WITH PICK-UP CAP

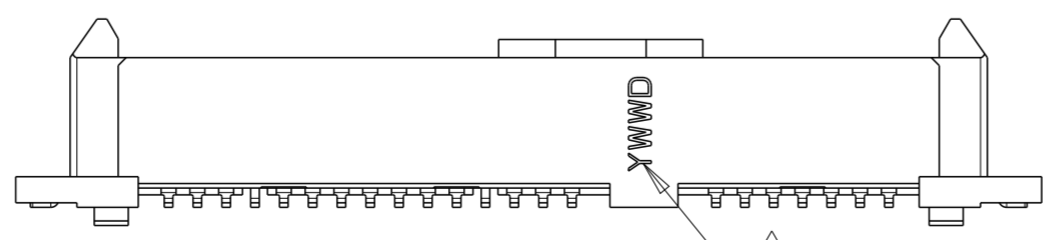
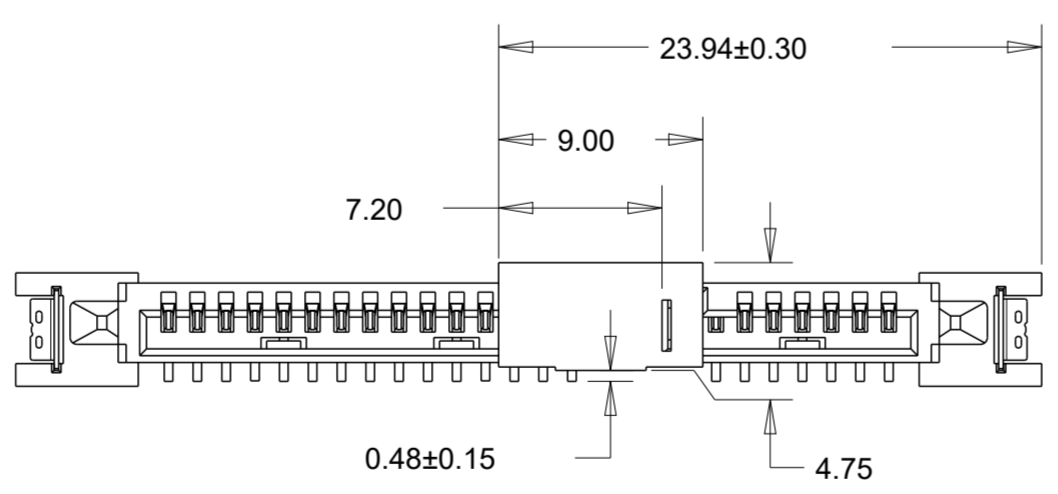

SCALE 3:1

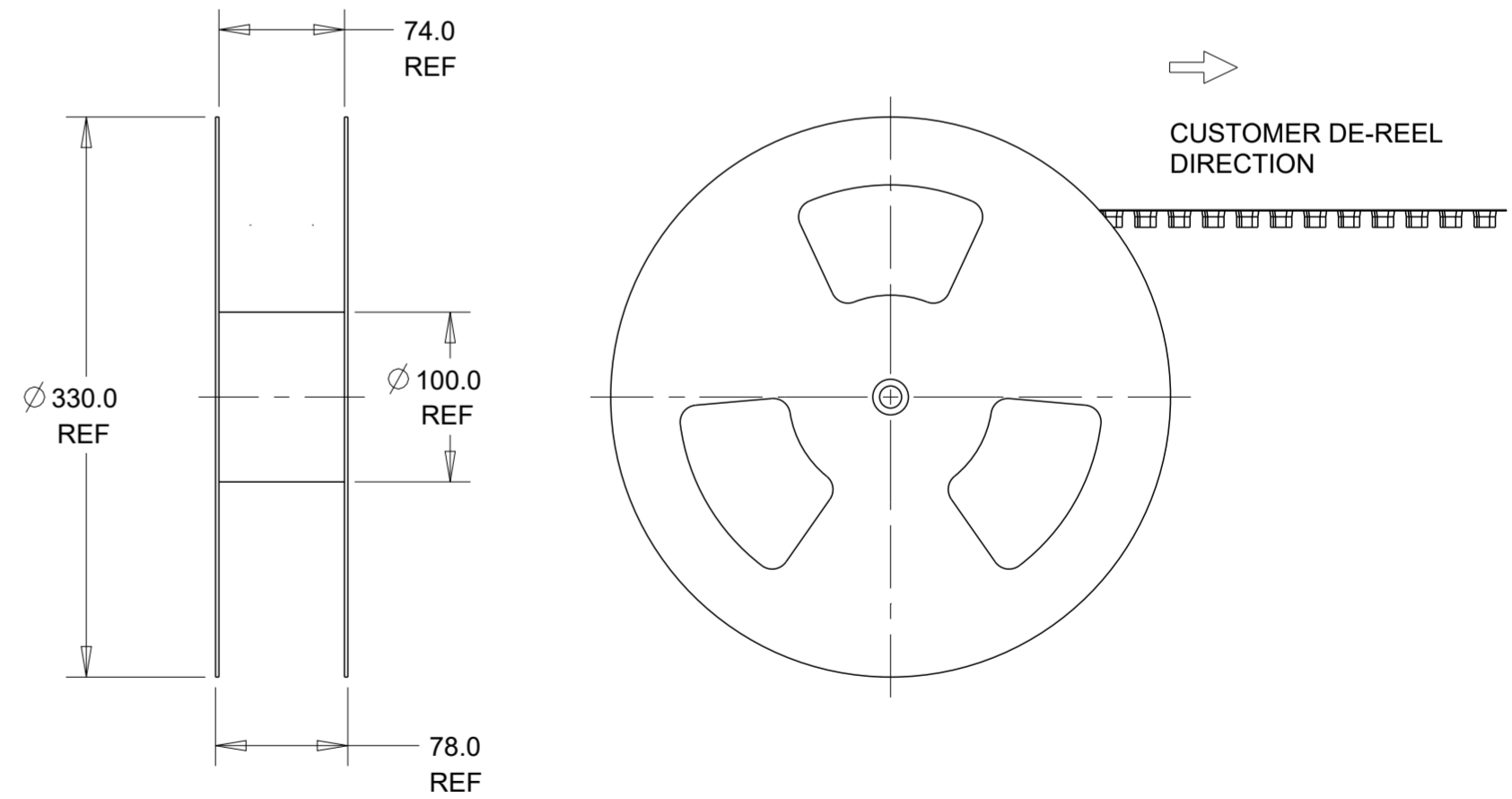

THIS DRAWING IS A CONTROLLED DOCUMENT.		DWN SK LEAW 28JUL2011	TE Connectivity Singapore
DIMENSIONS: mm		CHK SF LEONG 19SEP2011	
TOLERANCES UNLESS OTHERWISE SPECIFIED:		APVD SF LEONG 19SEP2011	
0 PLC ± 1 PLC ± 2 PLC ±0.20 3 PLC ± 4 PLC ± ANGLES ±3° FINISH		PRODUCT SPEC 108-51111 APPLICATION SPEC WEIGHT CUSTOMER DRAWING	
NAME: SATA BACKPLANE RECEPTACLE, VERTICAL, SMT LOW PROFILE			RESTRICTED TO
MATERIAL		SIZE A2	CAGE CODE 00779
		DRAWING NO. C-1735944	
		SCALE 2:1	SHEET 2 OF 2 REV B