

ABSTRACT

This user guide details the TCAN1046A/V CAN (Controller Area Network) EVM transceiver operation. The TCAN1046A/V CAN EVM is configurable for the SOIC package version of both TCAN1046A and TCAN1046AV. This user guide explains the EVM configurations for basic CAN evaluation, and various load and termination settings.

Table of Contents

1 Introduction	2
1.1 Overview.....	2
1.2 CAN EVM.....	2
2 EVM Setup and Operation	7
2.1 Overview and Basic Operation Settings.....	7
2.2 Using CAN Bus Load, Termination, and Protection Configurations.....	8
2.3 Using Customer Installable I/O Options for Current Limiting, Pullup and Pulldown, Noise Filtering.....	11
3 CAN EVM Configuration for TCAN1046A and TCAN1046AV	12

Trademarks

All trademarks are the property of their respective owners.

1 Introduction

1.1 Overview

TI offers a broad portfolio of high speed (HS) CAN transceivers compatible with the ISO11898-2 high speed CAN standards. These include 5-V V_{CC} only, 3.3-V V_{CC} only, 5-V V_{CC} with I/O level shifting and galvanic-isolated CAN transceivers. These CAN transceiver families include product mixes with varying features such as low-power standby modes with and without wake up, silent modes, loop back, and diagnostic modes.

The TCAN1046A/V EVM helps designers evaluate the operation and performance of TCAN1046A and TCAN1046AV transceivers in the SOIC package. It also provides bus termination, bus filtering, and protection concepts. It is easily configured by the customer to test different configurations with jumper settings, simple soldering tasks, and replacement of standard components, as well as both CAN interfaces on the device separately.

1.2 CAN EVM

The TCAN1046A/V EVM has simple connections to all necessary pins of the CAN transceiver device, and jumpers where necessary to provide flexibility for device pin and CAN bus configuration. There are test points (loops) for all main points where probing is necessary for evaluation such as GND, V_{CC} , TXD, RXD, CANH, CANL, STBY, and VIO. The EVM supports many options for CAN bus configuration. It is pre-configured with two 120- Ω resistors that are connected on the bus via jumpers: a single resistor is used with the EVM as a terminated line end (CAN is defined for 120- Ω impedance twisted pair cable) or both resistors in parallel for electrical measurements representing the 60- Ω load the transceiver “sees” in a properly terminated network (that is, 120- Ω termination resistors at both ends of the cable). The bus also has termination of two 60- Ω resistors in series with a 4.7nF capacitor to GND at the midpoint, all soldered down. This gives the option to test the other typical termination network on CAN buses.

[Figure 1-1](#) shows the EVM board image.

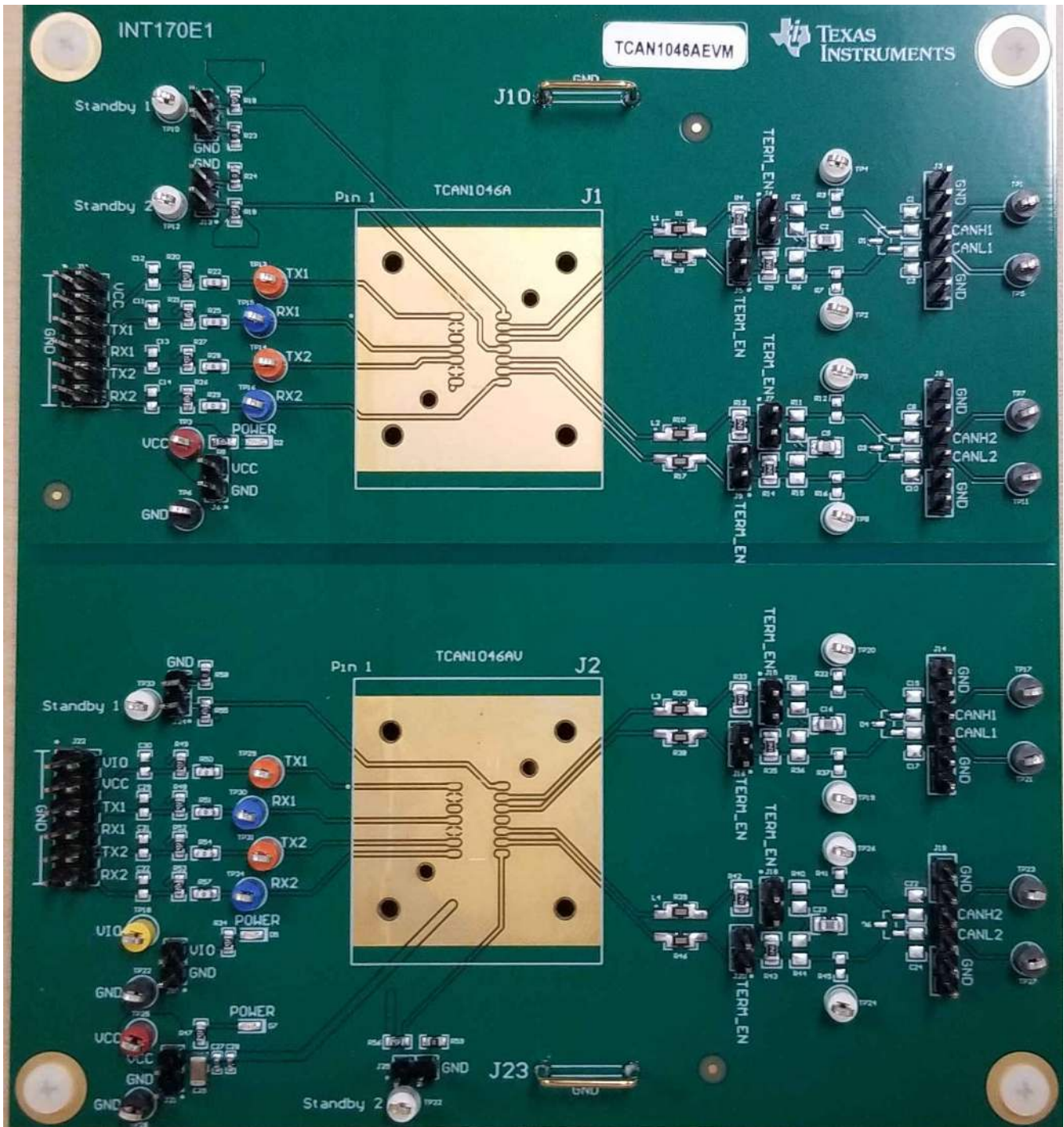

Figure 1-1. EVM PC Board

Figure 1-2 shows the EVM schematic.

1.2.1 Schematic

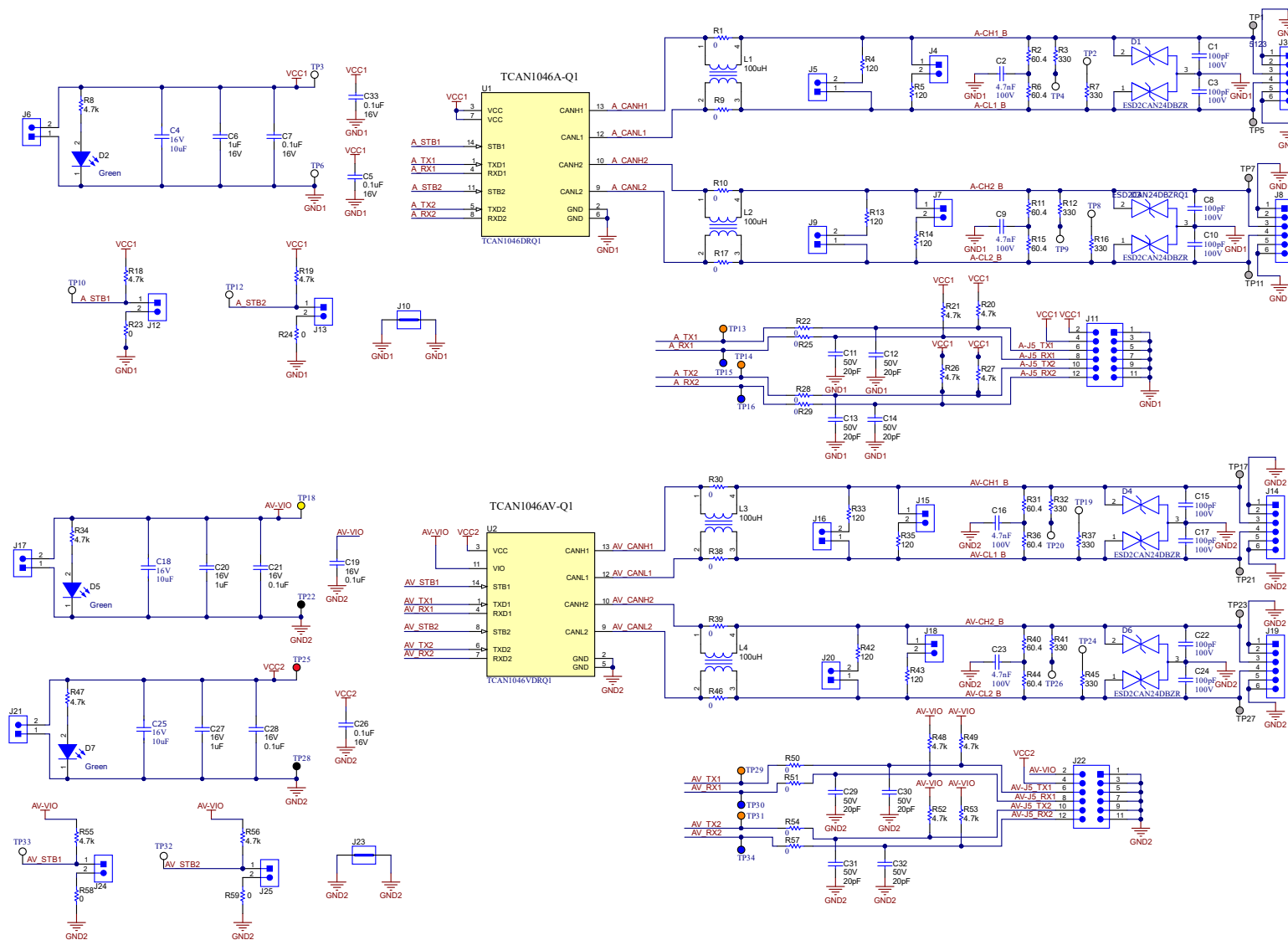

Figure 1-2. EVM Schematic

1.2.2 Jumper Connections

Table 1-1 lists the jumper connections for the EVM.

Table 1-1. Jumper Connections

Connection	Type	Description
J1	SOIC Socket	Removable socket adapter sized for 14-pin SOIC package type.
J2	SOIC Socket	Removable socket adapter sized for 14-pin SOIC package type.
J3	6-pin header	Used to monitor CANH1 and CANL1 on TCAN1046A CAN1 bus, GND connections available as well.
J4	2-pin jumper	Used to place R5 (120-Ω) on the TCAN1046A CAN1 bus. Use in combination with J5 to represent the combined 60-Ω CAN termination.
J5	2-pin jumper	Used to place R4 (120-Ω) on the TCAN1046A CAN1 bus. Use in combination with J4 to represent the combined 60-Ω CAN termination.
J6	2-pin header	VCC and GND connections for TCAN1046A.
J7	2-pin jumper	Used to place R14 (120-Ω) on the TCAN1046A CAN2 bus. Use in combination with J9 to represent the combined 60-Ω CAN termination.
J8	6-pin header	Used to monitor CANH2 and CANL2 on TCAN1046A CAN2 bus, GND connections available as well.
J9	2-pin jumper	Used to place R13 (120-Ω) on the TCAN1046A CAN2 bus. Use in combination with J7 to represent the combined 60-Ω CAN termination.
J10	GND rail	Ground rail connection
J11	12-pin header	Connections for VCC, TXD, and RXD for both CAN interfaces available, as well as GND connections.
J12	2-pin jumper	Used to apply either VCC or GND to Standby 1 (pin 14).
J13	2-pin jumper	Used to apply either VCC or GND to Standby 2 (pin 11).
J14	6-pin header	Used to monitor CANH1 and CANL1 on TCAN1046AV CAN1 bus, GND connections available as well.
J15	2-pin jumper	Used to place R35 (120-Ω) on the TCAN1046AV CAN1 bus. Use in combination with J16 to represent the combined 60-Ω CAN termination.
J16	2-pin jumper	Used to place R33 (120-Ω) on the TCAN1046AV CAN1 bus. Use in combination with J15 to represent the combined 60-Ω CAN termination.
J17	2-pin header	VIO logic supply and GND connections for TCAN1046AV.
J18	2-pin jumper	Used to place R43 (120-Ω) on the TCAN1046AV CAN2 bus. Use in combination with J20 to represent the combined 60-Ω CAN termination.
J19	6-pin header	Used to monitor CANH2 and CANL2 on TCAN1046AV CAN2 bus, GND connections available as well.
J20	2-pin jumper	Used to place R42 (120-Ω) on the TCAN1046AV CAN2 bus. Use in combination with J18 to represent the combined 60-Ω CAN termination.
J21	2-pin header	VCC supply and GND connections for TCAN1046AV.
J22	12-pin header	Connections for VCC, VIO, TXD, and RXD for both CAN interfaces available, as well as GND connections.
J23	GND rail	Ground rail connection
J24	2-pin jumper	Used to apply either VIO or GND to Standby 1 (pin 14).
J25	2-pin jumper	Used to apply either VIO or GND to Standby 2 (pin 8).

Table 1-1. Jumper Connections (continued)

Connection	Type	Description
TP1	Test Point	TCAN1046A CANH (CAN1)
TP2		TCAN1046A CANL (CAN1) via 330-Ω series resistor.
TP3		TCAN1046A VCC
TP4		TCAN1046A CANH (CAN1) via 330-Ω series resistor.
TP5		TCAN1046A CANL (CAN1)
TP6		TCAN1046A GND
TP7		TCAN1046A CANH (CAN2)
TP8		TCAN1046A CANL (CAN2) via 330-Ω series resistor.
TP9		TCAN1046A CANH (CAN2) via 330-Ω series resistor.
TP10		TCAN1046A Standby (CAN1)
TP11		TCAN1046A CANL (CAN2)
TP12		TCAN1046A Standby (CAN2)
TP13		TCAN1046A TXD (CAN1)
TP14		TCAN1046A TXD (CAN2)
TP15		TCAN1046A RXD (CAN1)
TP16		TCAN1046A RXD (CAN2)
TP17		TCAN1046AV CANH (CAN1)
TP18		TCAN1046AV VIO logic supply
TP19		TCAN1046AV CANL (CAN1) via 330-Ω series resistor.
TP20		TCAN1046AV CANH (CAN1) via 330-Ω series resistor.
TP21		TCAN1046AV CANL (CAN1)
TP22		TCAN1046AV GND
TP23		TCAN1046AV CANH (CAN2)
TP24		TCAN1046AV CANL (CAN2) via 330-Ω series resistor.
TP25		TCAN1046AV VCC
TP26		TCAN1046AV CANH (CAN2) via 330-Ω series resistor.
TP27		TCAN1046AV CANL (CAN2)
TP28		TCAN1046AV GND
TP29		TCAN1046AV TXD (CAN1)
TP30		TCAN1046AV RXD (CAN1)
TP31		TCAN1046AV TXD (CAN2)
TP32		TCAN1046AV Standby (CAN2)
TP33		TCAN1046AV Standby (CAN1)
TP34		TCAN1046AV RXD (CAN2)

2 EVM Setup and Operation

This section describes the setup and operation of the EVM for parameter performance evaluation.

2.1 Overview and Basic Operation Settings

2.1.1 V_{CC} Power Supply (J6 and J21)

The basic setup of the TCAN1046A/V EVM uses at most two power supply outputs required to evaluate a standard 5-V supply transceiver with the possibility of 3.3-V IO level device performance. For VCC the power supplied should meet 5-V and at least 100-mA. For the TCAN1046A footprint connect the 5-V supply to the J6. For the TCAN1046AV footprint connect the 5-V supply to the J21.

2.1.2 I/O Power Supply V_{IO} (J17)

When using the TCAN1046AV footprint, a power supply must be connected to J17. It is up to the user to decide if the J17 is connect to the same 5-V supply as VCC, or a seperate supply. The VIO pin can accept voltages down to 1.7 V. Connect this power supply via J17. The power supply must be capable of 1.8 V at 50 mA.

2.1.3 Transmit and Receive Connections(J11 and J22)

All transmit and receive (TXD and RXD) for both CAN interfaces, VIO, VCC, and GND connections are available on the J11 and J22 header. This allows the user the ability to evaluate the communication parameters of the transceiver in a straightforward manner.

Table 2-1. J11 Pin Definitions

Pin	Connection	Description
1	GND	Pin 2 and 6 of the transceiver, GND
2	VCC	Pin 3 and 7 of the transceiver, VCC
3	GND	Pin 2 and 6 of the transceiver, GND
4	VCC	Pin 3 and 7 of the transceiver, VCC
5	GND	Pin 2 and 6 of the transceiver, GND
6	TXD1	Pin 1 of the transceiver, TXD1
7	GND	Pin 2 and 6 of the transceiver, GND
8	RXD1	Pin 4 of transceiver, RXD1
9	GND	Pin 2 and 6 of the transceiver, GND
10	TXD2	Pin 5 of the transceiver, TXD2
11	GND	Pin 2 and 6 of the transceiver, GND
12	RXD2	Pin 8 of the transceiver, RXD2

Table 2-2. J22 Pin Definitions

Pin	Connection	Description
1	GND	Pin 2 and 5 of the transceiver, GND
2	VIO	Pin 11 of the transceiver, VIO
3	GND	Pin 2 and 5 of the transceiver, GND
4	VCC	Pin 3 of the transceiver, VIO
5	GND	Pin 2 and 5 of the transceiver, GND
6	TXD1	Pin 1 of the transceiver, TXD1
7	GND	Pin 2 and 5 of the transceiver, GND
8	RXD1	Pin 4 of transceiver, RXD1
9	GND	Pin 2 and 5 of the transceiver, GND
10	TXD2	Pin 6 of the transceiver, TXD2
11	GND	Pin 2 and 5 of the transceiver, GND
12	RXD2	Pin 7 of the transceiver, RXD2

This header is arranged to provide a separate ground for each signal pair (TXD/GND and RXD/GND). If the EVM is being used with lab equipment, connect separate cables to these main points via simple 2-pin header

connectors. If connecting the board to a processor-based system, connect a single cable with all power and signals via a 10-pin header cable to this port.

2.1.4 TXD Inputs (J11/J22, TP13 and TP14/TP29 and TP31)

For the TCAN1046A footprint, the TXD inputs (pin 1 and 5) of the transceiver; TXD1 is routed to pin 6 of J11, or TP13. The signal path to the J11 header is pre-installed with a 0-Ω series resistor, R22. TXD2 is routed to pin 10 of J11, or TP14, and the signal path to the J11 header is pre-installed with a 0-Ω resistor, R28.

For the TCAN1046AV footprint, the TXD inputs (pin 1 and 6) of the transceiver; TXD1 is routed to pin 6 of J22, or TP29. The signal path to the J22 header is pre-installed with a 0-Ω series resistor, R50. TXD2 is routed to pin 10 of J22, or TP31, and the signal path to the J22 header is pre-installed with a 0-Ω resistor, R54.

2.1.5 RXD Outputs (J11/J22, TP15 and TP16/TP30 and TP34)

For the TCAN1046A footprint, the RXD inputs (pin 4 and 8) of the transceiver; RXD1 is routed to pin 8 of J11, or TP15. The signal path to the J11 header is pre-installed with a 0-Ω series resistor, R25. RXD2 is routed to pin 12 of J11, or TP16, and the signal path to the J11 header is pre-installed with a 0-Ω resistor, R29.

For the TCAN1046AV footprint, the RXD inputs (pin 4 and 7) of the transceiver; RXD1 is routed to pin 8 of J22, or TP30. The signal path to the J22 header is pre-installed with a 0-Ω series resistor, R51. RXD2 is routed to pin 12 of J22, or TP34, and the signal path to the J22 header is pre-installed with a 0-Ω resistor, R57.

2.1.6 STBY inputs (J12 and J13/J24 and J25, TP10 and TP12/TP32 and TP33)

For the TCAN1046A footprint, pins 11 and 14 of the device are the STBY inputs. These pins control the state of the transceiver. STBY1 is routed to J12 or TP10. J12 allows the selection of VCC or GND to connect to the STBY1 pin, while TP10 is just for observation. STBY2 is routed to J13 or TP12. J13 allows the selection of VCC or GND to connect to the STBY2 pin, while TP12 is just for observation.

For the TCAN1046AV footprint, pins 8 and 14 of the device are the STBY inputs. These pins control the state of the transceiver. STBY1 is routed to J24 or TP33. J24 allows the selection of VCC or GND to connect to the STBY1 pin, while TP33 is just for observation. STBY2 is routed to J25 or TP32. J25 allows the selection of VCC or GND to connect to the STBY2 pin, while TP32 is just for observation.

2.1.7 Bus Observation (J3 or J8/J14 or J19)

For the TCAN1046A footprint, the CANH and CANL lines are available to be observed on an oscilloscope via the J3 or J8 headers. The CAN1 bus is routed to the J3 header, with CANH on pin 3, CANL on pin 4, and pins 1, 2, 5, and 6 are connected to GND. The CAN2 bus is routed to the J8 header, with CANH on pin 3, CANL on pin 4, and pins 1, 2, 5, and 6 are connected to GND.

For the TCAN1046AV footprint, the CANH and CANL lines are available to be observed on an oscilloscope via the J14 or J19 headers. The CAN1 bus is routed to the J14 header, with CANH on pin 3, CANL on pin 4, and pins 1, 2, 5, and 6 are connected to GND. The CAN2 bus is routed to the J19 header, with CANH on pin 3, CANL on pin 4, and pins 1, 2, 5, and 6 are connected to GND.

2.1.8 Bus protection

Footprints for the ESD2CAN24-Q1 ESD protection diodes are available on all CAN buses. D1, D3, D4, and D6 are all included in the SOT-23 package, which is a common package for ESD protection diodes for CAN interfaces.

2.2 Using CAN Bus Load, Termination, and Protection Configurations

The TCAN1046AEVM has several bus termination options for all available buses. For the TCAN1046A half of the board (top half), the termination on the CAN bus (CANH and CANL) can be configured with the J4 and J5 (CAN1) or J7 and J9 (CAN2) jumpers. For the TCAN1046AV half of the board (bottom half), the termination on the CAN bus (CANH and CANL) can be configured with the J15 and J16 (CAN1) or J18 and J20 (CAN2) jumpers. Each jumper adds 120-Ω termination to the respective bus. When using one resistor, the EVM is used as a terminated end of a bus. For electrical measurements to represent the total loading of the bus, use both 120-Ω resistors in parallel to give the standard 60-Ω load for parametric measurement. The footprint for split termination is also available and can be populated on all 4 buses. These components are not populated out of the box. [Table 2-3](#) summarizes how to use these termination options. If using split termination, match the resistors. Calculate the common mode filter frequency using: $f_c = 1 / (2\pi RC)$. Normally, the split capacitance is

in the range of 4.7 nF to 100 nF. Keep in mind this is the common-mode filter frequency, not a differential filter that impacts the differential CAN signal directly.

Table 2-3. TCAN1046A Bus Termination Configuration

Termination Configuration	120-Ω Resistors (CAN1)		120-Ω Resistors (CAN2)		Split Termination Footprints (CAN1)		Split Termination Footprints (CAN2)		Split Termination Footprints (CAN1)	Split Termination Footprints (CAN2)
	J5	J9	J4	J7	R2	R6	R15	R11		
Standard termination (120 Ω)	shorted		open		N/A		N/A		N/A	
60-Ω load - electrical parameters	shorted		shorted							
Split termination (common mode stabilization)	open		open		60 Ω		60 Ω		populated	

Table 2-4. TCAN1046AV Bus Termination Configuration

Termination Configuration	120-Ω Resistors (CAN1)		120-Ω Resistors (CAN2)		Split Termination Footprints (CAN1)		Split Termination Footprints (CAN2)		Split Termination Footprints (CAN1)	Split Termination Footprints (CAN2)
	J16	J20	J15	J18	R31	R36	R40	R44		
Standard termination (120 Ω)	shorted		open		N/A		N/A		N/A	
60-Ω load - electrical parameters	shorted		shorted							
Split termination (common mode stabilization)	open		open		60 Ω		60 Ω		populated	

The EVM also has footprints for various protection schemes to enhance robustness for extreme system-level EMC requirements. [Table 2-5](#) summarizes these options.

Table 2-5. TCAN1046A Protection and Filtering Configuration

Configuration	Footprint Reference	Use Case	Population and Description
Series resistors or common mode choke	R1/R9 or L1 (common footprint)	Direct CAN1 transceiver to bus connection	R1 and R9 populated with 0 Ω
		Series resistance protection, CAN1 transceiver to bus connection	R1 and R9 populated with MELF resistor as necessary for harsh EMC environment
		CM choke (CAN1 bus filter)	L1 populated with CM choke to filter noise as necessary for harsh EMC environment (default population)
	R10/R17 or L2 (common footprint)	Direct CAN2 transceiver to bus connection	R10 and R17 populated with 0 Ω
		Series resistance protection, CAN2 transceiver to bus connection	R10 and R17 populated with MELF resistor as necessary for harsh EMC environment
		CM choke (CAN2 bus filter)	L2 populated with CM choke to filter noise as necessary for harsh EMC environment (default population)
Bus filtering caps transient protection	C1/C3	Bus filter	Filter noise as necessary for harsh EMC environment. Use filter caps in combination with L1 CM choke.
	C8/C10		Filter noise as necessary for harsh EMC environment. Use filter caps in combination with L2 CM choke.

Table 2-5. TCAN1046A Protection and Filtering Configuration (continued)

Configuration	Footprint Reference	Use Case	Population and Description
	C1/C3 or D1	Transient and ESD protection	To add extra protection for system level transients and ESD protection, TVS diode population option via D1 footprint or varistor population via C1/C3 footprint.
	C8/C10 or D3		To add extra protection for system level transients and ESD protection, TVS diode population option via D3 footprint or varistor population via C8/C10 footprint.

Table 2-6. TCAN1046AV Protection and Filtering Configuration

Configuration	Footprint Reference	Use Case	Population and Description
Series resistors or common mode choke	R30/R38 or L3 (common footprint)	Direct CAN1 transceiver to bus connection	R30 and R38 populated with 0 Ω
		Series resistance protection, CAN1 transceiver to bus connection	R30 and R38 populated with MELF resistor as necessary for harsh EMC environment
		CM choke (CAN1 bus filter)	L3 populated with CM choke to filter noise as necessary for harsh EMC environment (default population)
	R39/R46 or L4 (common footprint)	Direct CAN2 transceiver to bus connection	R39 and R46 populated with 0 Ω
		Series resistance protection, CAN2 transceiver to bus connection	R39 and R46 populated with MELF resistor as necessary for harsh EMC environment
		CM choke (CAN2 bus filter)	L4 populated with CM choke to filter noise as necessary for harsh EMC environment (default population)
Bus filtering caps transient protection	C15/C17	Bus filter	Filter noise as necessary for harsh EMC environment. Use filter caps in combination with L3 CM choke.
	C22/C24		Filter noise as necessary for harsh EMC environment. Use filter caps in combination with L4 CM choke.
	C15/C17 or D4	Transient and ESD protection	To add extra protection for system level transients and ESD protection, TVS diode population option via D4 footprint or varistor population via C15/C17 footprint.
	C22/C24 or D6		To add extra protection for system level transients and ESD protection, TVS diode population option via D6 footprint or varistor population via C22/C24 footprint.

2.3 Using Customer Installable I/O Options for Current Limiting, Pullup and Pulldown, Noise Filtering

The TCAN1046AEVM has footprints on the PCB for the installation of various filtering and protection options to adapt the EVM to match CAN network topology requirements if the EVM is being used as a CAN node.

Each digital input or output pin has footprints allowing for series current-limiting resistors (default populated with 0 Ω), pull-up resistors (defaulted with 4.7 k Ω), and a capacitor to GND which allows for RC filters when configured with a series resistor. [Table 2-7](#) lists these features for each of the digital input and output pins of the EVM. Replace or populate the RC components as necessary for the application.

Table 2-7. TCAN1046A RC Filter and Protection Lists

Device Pin			Jumperable		Series R	Pullup	C to GND
No.	Description	Type	Pullup	Pulldown			
1/5	TXD1/TXD2	Input	N/A	N/A	R22/R28	R20/R27 PU	C12/C13
4/8	RXD1/RXD2	Output	N/A	N/A	R25/R29	R21/R26 PU	C11/C14

Table 2-8. TCAN1046AV RC Filter and Protection Lists

Device Pin			Jumperable		Series R	Pullup	C to GND
No.	Description	Type	Pullup	Pulldown			
1/6	TXD1/TXD2	Input	N/A	N/A	R50/R54	R49/R52 PU	C30/C31
4/7	RXD1/RXD2	Output	N/A	N/A	R51/R57	R48/R53 PU	C29/C32

3 CAN EVM Configuration for TCAN1046A and TCAN1046AV

The TCAN1046A/V device interfaces CAN protocol controllers with the physical bus in accordance to the ISO 11898 standard. These devices are compatible with the ISO 11898 High Speed CAN (Controller Area Network) Physical Layer standards: 11898-2. These devices are designed for use of up to 5 Mbit CAN systems, and they include many protection features providing device and CAN network robustness.

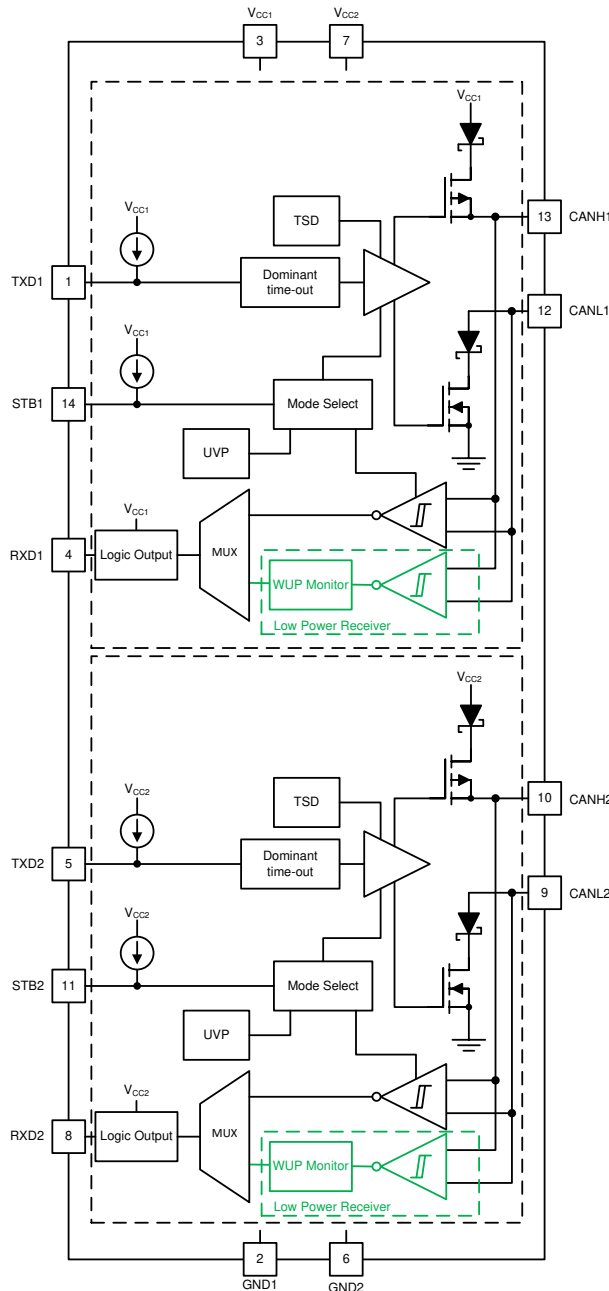

Figure 3-1. TCAN1046A Block Diagram

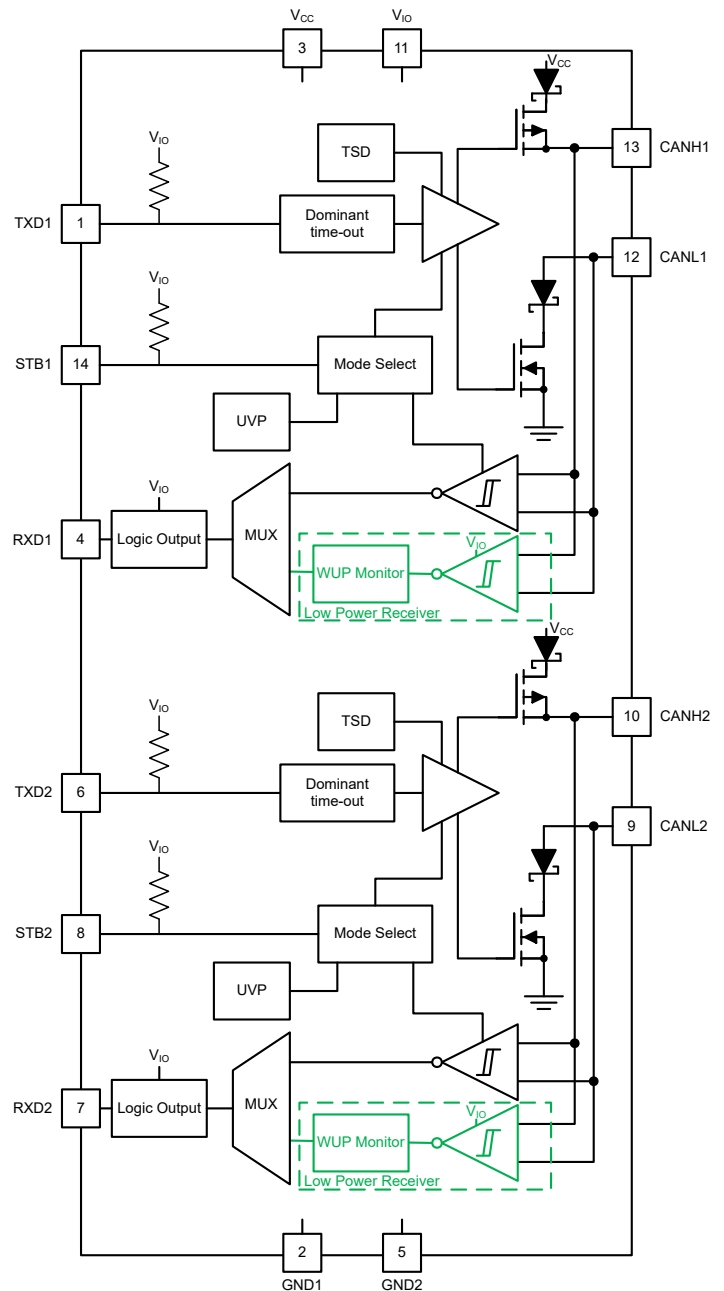

Figure 3-2. TCAN1046AV Block Diagram

STANDARD TERMS FOR EVALUATION MODULES

1. *Delivery:* TI delivers TI evaluation boards, kits, or modules, including any accompanying demonstration software, components, and/or documentation which may be provided together or separately (collectively, an "EVM" or "EVMs") to the User ("User") in accordance with the terms set forth herein. User's acceptance of the EVM is expressly subject to the following terms.
 - 1.1 EVMs are intended solely for product or software developers for use in a research and development setting to facilitate feasibility evaluation, experimentation, or scientific analysis of TI semiconductors products. EVMs have no direct function and are not finished products. EVMs shall not be directly or indirectly assembled as a part or subassembly in any finished product. For clarification, any software or software tools provided with the EVM ("Software") shall not be subject to the terms and conditions set forth herein but rather shall be subject to the applicable terms that accompany such Software
 - 1.2 EVMs are not intended for consumer or household use. EVMs may not be sold, sublicensed, leased, rented, loaned, assigned, or otherwise distributed for commercial purposes by Users, in whole or in part, or used in any finished product or production system.
2. *Limited Warranty and Related Remedies/Disclaimers:*
 - 2.1 These terms do not apply to Software. The warranty, if any, for Software is covered in the applicable Software License Agreement.
 - 2.2 TI warrants that the TI EVM will conform to TI's published specifications for ninety (90) days after the date TI delivers such EVM to User. Notwithstanding the foregoing, TI shall not be liable for a nonconforming EVM if (a) the nonconformity was caused by neglect, misuse or mistreatment by an entity other than TI, including improper installation or testing, or for any EVMs that have been altered or modified in any way by an entity other than TI, (b) the nonconformity resulted from User's design, specifications or instructions for such EVMs or improper system design, or (c) User has not paid on time. Testing and other quality control techniques are used to the extent TI deems necessary. TI does not test all parameters of each EVM. User's claims against TI under this Section 2 are void if User fails to notify TI of any apparent defects in the EVMs within ten (10) business days after delivery, or of any hidden defects with ten (10) business days after the defect has been detected.
 - 2.3 TI's sole liability shall be at its option to repair or replace EVMs that fail to conform to the warranty set forth above, or credit User's account for such EVM. TI's liability under this warranty shall be limited to EVMs that are returned during the warranty period to the address designated by TI and that are determined by TI not to conform to such warranty. If TI elects to repair or replace such EVM, TI shall have a reasonable time to repair such EVM or provide replacements. Repaired EVMs shall be warranted for the remainder of the original warranty period. Replaced EVMs shall be warranted for a new full ninety (90) day warranty period.

WARNING

Evaluation Kits are intended solely for use by technically qualified, professional electronics experts who are familiar with the dangers and application risks associated with handling electrical mechanical components, systems, and subsystems.

User shall operate the Evaluation Kit within TI's recommended guidelines and any applicable legal or environmental requirements as well as reasonable and customary safeguards. Failure to set up and/or operate the Evaluation Kit within TI's recommended guidelines may result in personal injury or death or property damage. Proper set up entails following TI's instructions for electrical ratings of interface circuits such as input, output and electrical loads.

NOTE:

EXPOSURE TO ELECTROSTATIC DISCHARGE (ESD) MAY CAUSE DEGRADATION OR FAILURE OF THE EVALUATION KIT; TI RECOMMENDS STORAGE OF THE EVALUATION KIT IN A PROTECTIVE ESD BAG.

3 Regulatory Notices:

3.1 United States

3.1.1 Notice applicable to EVMs not FCC-Approved:

FCC NOTICE: This kit is designed to allow product developers to evaluate electronic components, circuitry, or software associated with the kit to determine whether to incorporate such items in a finished product and software developers to write software applications for use with the end product. This kit is not a finished product and when assembled may not be resold or otherwise marketed unless all required FCC equipment authorizations are first obtained. Operation is subject to the condition that this product not cause harmful interference to licensed radio stations and that this product accept harmful interference. Unless the assembled kit is designed to operate under part 15, part 18 or part 95 of this chapter, the operator of the kit must operate under the authority of an FCC license holder or must secure an experimental authorization under part 5 of this chapter.

3.1.2 For EVMs annotated as FCC – FEDERAL COMMUNICATIONS COMMISSION Part 15 Compliant:

CAUTION

This device complies with part 15 of the FCC Rules. Operation is subject to the following two conditions: (1) This device may not cause harmful interference, and (2) this device must accept any interference received, including interference that may cause undesired operation.

Changes or modifications not expressly approved by the party responsible for compliance could void the user's authority to operate the equipment.

FCC Interference Statement for Class A EVM devices

NOTE: This equipment has been tested and found to comply with the limits for a Class A digital device, pursuant to part 15 of the FCC Rules. These limits are designed to provide reasonable protection against harmful interference when the equipment is operated in a commercial environment. This equipment generates, uses, and can radiate radio frequency energy and, if not installed and used in accordance with the instruction manual, may cause harmful interference to radio communications. Operation of this equipment in a residential area is likely to cause harmful interference in which case the user will be required to correct the interference at his own expense.

FCC Interference Statement for Class B EVM devices

NOTE: This equipment has been tested and found to comply with the limits for a Class B digital device, pursuant to part 15 of the FCC Rules. These limits are designed to provide reasonable protection against harmful interference in a residential installation. This equipment generates, uses and can radiate radio frequency energy and, if not installed and used in accordance with the instructions, may cause harmful interference to radio communications. However, there is no guarantee that interference will not occur in a particular installation. If this equipment does cause harmful interference to radio or television reception, which can be determined by turning the equipment off and on, the user is encouraged to try to correct the interference by one or more of the following measures:

- Reorient or relocate the receiving antenna.
- Increase the separation between the equipment and receiver.
- Connect the equipment into an outlet on a circuit different from that to which the receiver is connected.
- Consult the dealer or an experienced radio/TV technician for help.

3.2 Canada

3.2.1 For EVMs issued with an Industry Canada Certificate of Conformance to RSS-210 or RSS-247

Concerning EVMs Including Radio Transmitters:

This device complies with Industry Canada license-exempt RSSs. Operation is subject to the following two conditions:

(1) this device may not cause interference, and (2) this device must accept any interference, including interference that may cause undesired operation of the device.

Concernant les EVMs avec appareils radio:

Le présent appareil est conforme aux CNR d'Industrie Canada applicables aux appareils radio exempts de licence. L'exploitation est autorisée aux deux conditions suivantes: (1) l'appareil ne doit pas produire de brouillage, et (2) l'utilisateur de l'appareil doit accepter tout brouillage radioélectrique subi, même si le brouillage est susceptible d'en compromettre le fonctionnement.

Concerning EVMs Including Detachable Antennas:

Under Industry Canada regulations, this radio transmitter may only operate using an antenna of a type and maximum (or lesser) gain approved for the transmitter by Industry Canada. To reduce potential radio interference to other users, the antenna type and its gain should be so chosen that the equivalent isotropically radiated power (e.i.r.p.) is not more than that necessary for successful communication. This radio transmitter has been approved by Industry Canada to operate with the antenna types listed in the user guide with the maximum permissible gain and required antenna impedance for each antenna type indicated. Antenna types not included in this list, having a gain greater than the maximum gain indicated for that type, are strictly prohibited for use with this device.

Concernant les EVMs avec antennes détachables

Conformément à la réglementation d'Industrie Canada, le présent émetteur radio peut fonctionner avec une antenne d'un type et d'un gain maximal (ou inférieur) approuvé pour l'émetteur par Industrie Canada. Dans le but de réduire les risques de brouillage radioélectrique à l'intention des autres utilisateurs, il faut choisir le type d'antenne et son gain de sorte que la puissance isotrope rayonnée équivalente (p.i.r.e.) ne dépasse pas l'intensité nécessaire à l'établissement d'une communication satisfaisante. Le présent émetteur radio a été approuvé par Industrie Canada pour fonctionner avec les types d'antenne énumérés dans le manuel d'usage et ayant un gain admissible maximal et l'impédance requise pour chaque type d'antenne. Les types d'antenne non inclus dans cette liste, ou dont le gain est supérieur au gain maximal indiqué, sont strictement interdits pour l'exploitation de l'émetteur.

3.3 Japan

3.3.1 *Notice for EVMs delivered in Japan:* Please see http://www.tij.co.jp/lstds/ti_ja/general/eStore/notice_01.page 日本国内に輸入される評価用キット、ボードについては、次のところをご覧ください。
http://www.tij.co.jp/lstds/ti_ja/general/eStore/notice_01.page

3.3.2 *Notice for Users of EVMs Considered "Radio Frequency Products" in Japan:* EVMs entering Japan may not be certified by TI as conforming to Technical Regulations of Radio Law of Japan.

If User uses EVMs in Japan, not certified to Technical Regulations of Radio Law of Japan, User is required to follow the instructions set forth by Radio Law of Japan, which includes, but is not limited to, the instructions below with respect to EVMs (which for the avoidance of doubt are stated strictly for convenience and should be verified by User):

1. Use EVMs in a shielded room or any other test facility as defined in the notification #173 issued by Ministry of Internal Affairs and Communications on March 28, 2006, based on Sub-section 1.1 of Article 6 of the Ministry's Rule for Enforcement of Radio Law of Japan,
2. Use EVMs only after User obtains the license of Test Radio Station as provided in Radio Law of Japan with respect to EVMs, or
3. Use of EVMs only after User obtains the Technical Regulations Conformity Certification as provided in Radio Law of Japan with respect to EVMs. Also, do not transfer EVMs, unless User gives the same notice above to the transferee. Please note that if User does not follow the instructions above, User will be subject to penalties of Radio Law of Japan.

【無線電波を送信する製品の開発キットをお使いになる際の注意事項】 開発キットの中には技術基準適合証明を受けていないものがあります。技術適合証明を受けていないものご使用に際しては、電波法遵守のため、以下のいずれかの措置を取っていただく必要がありますのでご注意ください。

1. 電波法施行規則第6条第1項第1号に基づく平成18年3月28日総務省告示第173号で定められた電波暗室等の試験設備でご使用いただく。
2. 実験局の免許を取得後ご使用いただく。
3. 技術基準適合証明を取得後ご使用いただく。

なお、本製品は、上記の「ご使用にあたっての注意」を譲渡先、移転先に通知しない限り、譲渡、移転できないものとします。

上記を遵守頂けない場合は、電波法の罰則が適用される可能性があることをご留意ください。日本テキサス・インスツルメンツ株式会社
東京都新宿区西新宿 6 丁目 2 4 番 1 号
西新宿三井ビル

3.3.3 *Notice for EVMs for Power Line Communication:* Please see http://www.tij.co.jp/lstds/ti_ja/general/eStore/notice_02.page 電力線搬送波通信についての開発キットをお使いになる際の注意事項については、次のところをご覧ください。
http://www.tij.co.jp/lstds/ti_ja/general/eStore/notice_02.page

3.4 European Union

3.4.1 *For EVMs subject to EU Directive 2014/30/EU (Electromagnetic Compatibility Directive):*

This is a class A product intended for use in environments other than domestic environments that are connected to a low-voltage power-supply network that supplies buildings used for domestic purposes. In a domestic environment this product may cause radio interference in which case the user may be required to take adequate measures.

-
- 4 *EVM Use Restrictions and Warnings:*
- 4.1 EVMS ARE NOT FOR USE IN FUNCTIONAL SAFETY AND/OR SAFETY CRITICAL EVALUATIONS, INCLUDING BUT NOT LIMITED TO EVALUATIONS OF LIFE SUPPORT APPLICATIONS.
- 4.2 User must read and apply the user guide and other available documentation provided by TI regarding the EVM prior to handling or using the EVM, including without limitation any warning or restriction notices. The notices contain important safety information related to, for example, temperatures and voltages.
- 4.3 *Safety-Related Warnings and Restrictions:*
- 4.3.1 User shall operate the EVM within TI's recommended specifications and environmental considerations stated in the user guide, other available documentation provided by TI, and any other applicable requirements and employ reasonable and customary safeguards. Exceeding the specified performance ratings and specifications (including but not limited to input and output voltage, current, power, and environmental ranges) for the EVM may cause personal injury or death, or property damage. If there are questions concerning performance ratings and specifications, User should contact a TI field representative prior to connecting interface electronics including input power and intended loads. Any loads applied outside of the specified output range may also result in unintended and/or inaccurate operation and/or possible permanent damage to the EVM and/or interface electronics. Please consult the EVM user guide prior to connecting any load to the EVM output. If there is uncertainty as to the load specification, please contact a TI field representative. During normal operation, even with the inputs and outputs kept within the specified allowable ranges, some circuit components may have elevated case temperatures. These components include but are not limited to linear regulators, switching transistors, pass transistors, current sense resistors, and heat sinks, which can be identified using the information in the associated documentation. When working with the EVM, please be aware that the EVM may become very warm.
- 4.3.2 EVMs are intended solely for use by technically qualified, professional electronics experts who are familiar with the dangers and application risks associated with handling electrical mechanical components, systems, and subsystems. User assumes all responsibility and liability for proper and safe handling and use of the EVM by User or its employees, affiliates, contractors or designees. User assumes all responsibility and liability to ensure that any interfaces (electronic and/or mechanical) between the EVM and any human body are designed with suitable isolation and means to safely limit accessible leakage currents to minimize the risk of electrical shock hazard. User assumes all responsibility and liability for any improper or unsafe handling or use of the EVM by User or its employees, affiliates, contractors or designees.
- 4.4 User assumes all responsibility and liability to determine whether the EVM is subject to any applicable international, federal, state, or local laws and regulations related to User's handling and use of the EVM and, if applicable, User assumes all responsibility and liability for compliance in all respects with such laws and regulations. User assumes all responsibility and liability for proper disposal and recycling of the EVM consistent with all applicable international, federal, state, and local requirements.
5. *Accuracy of Information:* To the extent TI provides information on the availability and function of EVMs, TI attempts to be as accurate as possible. However, TI does not warrant the accuracy of EVM descriptions, EVM availability or other information on its websites as accurate, complete, reliable, current, or error-free.
6. *Disclaimers:*
- 6.1 EXCEPT AS SET FORTH ABOVE, EVMS AND ANY MATERIALS PROVIDED WITH THE EVM (INCLUDING, BUT NOT LIMITED TO, REFERENCE DESIGNS AND THE DESIGN OF THE EVM ITSELF) ARE PROVIDED "AS IS" AND "WITH ALL FAULTS." TI DISCLAIMS ALL OTHER WARRANTIES, EXPRESS OR IMPLIED, REGARDING SUCH ITEMS, INCLUDING BUT NOT LIMITED TO ANY EPIDEMIC FAILURE WARRANTY OR IMPLIED WARRANTIES OF MERCHANTABILITY OR FITNESS FOR A PARTICULAR PURPOSE OR NON-INFRINGEMENT OF ANY THIRD PARTY PATENTS, COPYRIGHTS, TRADE SECRETS OR OTHER INTELLECTUAL PROPERTY RIGHTS.
- 6.2 EXCEPT FOR THE LIMITED RIGHT TO USE THE EVM SET FORTH HEREIN, NOTHING IN THESE TERMS SHALL BE CONSTRUED AS GRANTING OR CONFERRING ANY RIGHTS BY LICENSE, PATENT, OR ANY OTHER INDUSTRIAL OR INTELLECTUAL PROPERTY RIGHT OF TI, ITS SUPPLIERS/LICENSORS OR ANY OTHER THIRD PARTY, TO USE THE EVM IN ANY FINISHED END-USER OR READY-TO-USE FINAL PRODUCT, OR FOR ANY INVENTION, DISCOVERY OR IMPROVEMENT, REGARDLESS OF WHEN MADE, CONCEIVED OR ACQUIRED.
7. *USER'S INDEMNITY OBLIGATIONS AND REPRESENTATIONS.* USER WILL DEFEND, INDEMNIFY AND HOLD TI, ITS LICENSORS AND THEIR REPRESENTATIVES HARMLESS FROM AND AGAINST ANY AND ALL CLAIMS, DAMAGES, LOSSES, EXPENSES, COSTS AND LIABILITIES (COLLECTIVELY, "CLAIMS") ARISING OUT OF OR IN CONNECTION WITH ANY HANDLING OR USE OF THE EVM THAT IS NOT IN ACCORDANCE WITH THESE TERMS. THIS OBLIGATION SHALL APPLY WHETHER CLAIMS ARISE UNDER STATUTE, REGULATION, OR THE LAW OF TORT, CONTRACT OR ANY OTHER LEGAL THEORY, AND EVEN IF THE EVM FAILS TO PERFORM AS DESCRIBED OR EXPECTED.

8. *Limitations on Damages and Liability:*

8.1 *General Limitations.* IN NO EVENT SHALL TI BE LIABLE FOR ANY SPECIAL, COLLATERAL, INDIRECT, PUNITIVE, INCIDENTAL, CONSEQUENTIAL, OR EXEMPLARY DAMAGES IN CONNECTION WITH OR ARISING OUT OF THESE TERMS OR THE USE OF THE EVMS , REGARDLESS OF WHETHER TI HAS BEEN ADVISED OF THE POSSIBILITY OF SUCH DAMAGES. EXCLUDED DAMAGES INCLUDE, BUT ARE NOT LIMITED TO, COST OF REMOVAL OR REINSTALLATION, ANCILLARY COSTS TO THE PROCUREMENT OF SUBSTITUTE GOODS OR SERVICES, RETESTING, OUTSIDE COMPUTER TIME, LABOR COSTS, LOSS OF GOODWILL, LOSS OF PROFITS, LOSS OF SAVINGS, LOSS OF USE, LOSS OF DATA, OR BUSINESS INTERRUPTION. NO CLAIM, SUIT OR ACTION SHALL BE BROUGHT AGAINST TI MORE THAN TWELVE (12) MONTHS AFTER THE EVENT THAT GAVE RISE TO THE CAUSE OF ACTION HAS OCCURRED.

8.2 *Specific Limitations.* IN NO EVENT SHALL TI'S AGGREGATE LIABILITY FROM ANY USE OF AN EVM PROVIDED HEREUNDER, INCLUDING FROM ANY WARRANTY, INDEMNITY OR OTHER OBLIGATION ARISING OUT OF OR IN CONNECTION WITH THESE TERMS, , EXCEED THE TOTAL AMOUNT PAID TO TI BY USER FOR THE PARTICULAR EVM(S) AT ISSUE DURING THE PRIOR TWELVE (12) MONTHS WITH RESPECT TO WHICH LOSSES OR DAMAGES ARE CLAIMED. THE EXISTENCE OF MORE THAN ONE CLAIM SHALL NOT ENLARGE OR EXTEND THIS LIMIT.

9. *Return Policy.* Except as otherwise provided, TI does not offer any refunds, returns, or exchanges. Furthermore, no return of EVM(s) will be accepted if the package has been opened and no return of the EVM(s) will be accepted if they are damaged or otherwise not in a resalable condition. If User feels it has been incorrectly charged for the EVM(s) it ordered or that delivery violates the applicable order, User should contact TI. All refunds will be made in full within thirty (30) working days from the return of the components(s), excluding any postage or packaging costs.

10. *Governing Law:* These terms and conditions shall be governed by and interpreted in accordance with the laws of the State of Texas, without reference to conflict-of-laws principles. User agrees that non-exclusive jurisdiction for any dispute arising out of or relating to these terms and conditions lies within courts located in the State of Texas and consents to venue in Dallas County, Texas. Notwithstanding the foregoing, any judgment may be enforced in any United States or foreign court, and TI may seek injunctive relief in any United States or foreign court.

Mailing Address: Texas Instruments, Post Office Box 655303, Dallas, Texas 75265
Copyright © 2019, Texas Instruments Incorporated

IMPORTANT NOTICE AND DISCLAIMER

TI PROVIDES TECHNICAL AND RELIABILITY DATA (INCLUDING DATA SHEETS), DESIGN RESOURCES (INCLUDING REFERENCE DESIGNS), APPLICATION OR OTHER DESIGN ADVICE, WEB TOOLS, SAFETY INFORMATION, AND OTHER RESOURCES "AS IS" AND WITH ALL FAULTS, AND DISCLAIMS ALL WARRANTIES, EXPRESS AND IMPLIED, INCLUDING WITHOUT LIMITATION ANY IMPLIED WARRANTIES OF MERCHANTABILITY, FITNESS FOR A PARTICULAR PURPOSE OR NON-INFRINGEMENT OF THIRD PARTY INTELLECTUAL PROPERTY RIGHTS.

These resources are intended for skilled developers designing with TI products. You are solely responsible for (1) selecting the appropriate TI products for your application, (2) designing, validating and testing your application, and (3) ensuring your application meets applicable standards, and any other safety, security, regulatory or other requirements.

These resources are subject to change without notice. TI grants you permission to use these resources only for development of an application that uses the TI products described in the resource. Other reproduction and display of these resources is prohibited. No license is granted to any other TI intellectual property right or to any third party intellectual property right. TI disclaims responsibility for, and you will fully indemnify TI and its representatives against, any claims, damages, costs, losses, and liabilities arising out of your use of these resources.

TI's products are provided subject to [TI's Terms of Sale](#) or other applicable terms available either on ti.com or provided in conjunction with such TI products. TI's provision of these resources does not expand or otherwise alter TI's applicable warranties or warranty disclaimers for TI products.

TI objects to and rejects any additional or different terms you may have proposed.

Mailing Address: Texas Instruments, Post Office Box 655303, Dallas, Texas 75265
Copyright © 2022, Texas Instruments Incorporated