

4

3

2

1

THIS DRAWING IS UNPUBLISHED. RELEASED FOR PUBLICATION  
 © COPYRIGHT - By - ALL RIGHTS RESERVED.

LOC		DIST		REVISIONS			
P	LTR	DESCRIPTION		DATE	DWN	APVD	
AD	00	A2	REVISED PER ECO-15-004048		16MAR2015	NK	RH



MATERIALS

COMPONENT NAME	BASE MATERIAL	FINISH
CASE	LCP, BLACK, UL94 V-0	
TERMINAL, WIRE LUG (GOLD)	BRASS	GOLD OVER NICKEL
TERMINAL, PC & RA (GOLD)	BRASS	GOLD OVER NICKEL IN CONTACT AREA, TIN OVER NICKEL IN SOLDER AREA
TERMINAL, WIRE LUG & PC (SILVER)	SILVER CLAD COPPER	SILVER OVER NICKEL
CONTACT (GOLD)	COPPER ALLOY OR BRASS	GOLD OVER NICKEL
CONTACT (SILVER)	SILVER CLAD COPPER OR COPPER	SILVER OVER NICKEL
FRAME	STEEL	TIN OVER COPPER
SPRING	MUSIC WIRE	
PLUNGER BUTTON	NYLON 6/6, BLACK, RED OR BLUE, UL94 HB	
GUIDE, CC & FF SWITCHES ONLY	NYLON 6/6, WHITE	

SPECIFICATIONS

RATING	GOLD: .4VA MAX. @ 20VDC OR PEAK AC RESISTIVE SILVER: 1A @ 125VAC OR 28 VDC RESISTIVE
INITIAL TERMINATION RESISTANCE	20 MILLIOHMS MAX.
INSULATION RESISTANCE	1,000 MEGOHMS MIN @ 500 VDC
DIELECTRIC STRENGTH	1,000 VOLTS RMS AT SEA LEVEL
TIMING	BREAK BEFORE MAKE
PLUNGER TRAVEL	.030
ACTUATION FORCE	50 TO 400 GRAMS
LIFE EXPECTANCY	.4VA: 100,000 1A: 60,000
OPERATING TEMPERATURE	-30°C TO +95°C
STORAGE TEMPERATURE	-30°C TO +95°C
TERMINAL SEAL	SINGLE POLE: EPOXY DOUBLE POLE: EPOXY OPTIONAL









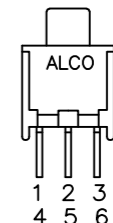
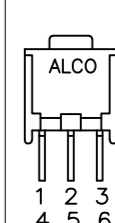
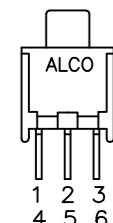
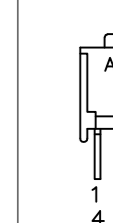

NOTES:

- TERMINAL NUMBERS ARE FOR REFERENCE ONLY AND DO NOT APPEAR ON SWITCHES
- ALL MATERIALS AND FINISHES COMPLY WITH EU DIRECTIVE 2002/95/ES OF 27JAN2003 (ROHS)
-  CENTER TERMINAL PRESENT ON DOUBLE THROW SWITCHES ONLY.
-  OBSOLETE.

PART NUMBER MATRIX

MODEL	POLES	RATING	FUNCTION	PLATING	TERMINATIONS	BUTTON COLOR	04
TP	1	1=GOLD .4VA	C=SPST MOMENTARY	G=GOLD	BLANK=WIRE LUG	0=BLACK	
	2(1+1)	3=SILVER 1 AMP 1	F=SPDT MOMENTARY	BLANK=SILVER 1	PC=PRINTED CIRCUIT	2=RED	
					RA=RIGHT ANGLE 1	6=BLUE	

NOTES:  
1. SILVER ONLY AVAILABLE IN WIRE LUG AND PC TERMINATIONS

P/N	ALCO P/N	POLES	THROWS	PLATING	TERMINALS	BUTTON COLOR	FUNCTION		CONNECTED TERMINALS	
										
1825095-1	TP11CGPC004	1	1	GOLD	PC	BLACK	OFF	MOM	OFF	1-3
1825095-2	TP11CGPC204	1	1	GOLD	PC	RED	OFF	MOM	OFF	1-3
1825095-3	TP11CGRA004	1	1	GOLD	RIGHT ANGLE	BLACK	OFF	MOM	OFF	1-3
 1825095-4	TP11CGRA204	1	1	GOLD	RIGHT ANGLE	RED	OFF	MOM	OFF	1-3
 1825095-5	TP11CGRA604	1	1	GOLD	RIGHT ANGLE	BLUE	OFF	MOM	OFF	1-3
1825095-6	TP11FGPC004	1	2	GOLD	PC	BLACK	ON	MOM	1-2	2-3
 1825095-7	TP11FGPC204	1	2	GOLD	PC	RED	ON	MOM	1-2	2-3
 1825095-8	TP11FGRA004	1	2	GOLD	RIGHT ANGLE	BLACK	ON	MOM	1-2	2-3
 1825095-9	TP11FGRA204	1	2	GOLD	RIGHT ANGLE	RED	ON	MOM	1-2	2-3
 1-1825095-0	TP11FGRA604	1	2	GOLD	RIGHT ANGLE	BLUE	ON	MOM	1-2	2-3
 1-1825095-1	TP21CCGRA004	2(1+1)	1	GOLD	RIGHT ANGLE	BLACK	OFF	MOM	OFF	1-3
 1-1825095-2	TP21CCGRA204	2(1+1)	1	GOLD	RIGHT ANGLE	RED	OFF	MOM	OFF	1-3
 1-1825095-3	TP21FFGRA004	2(1+1)	2	GOLD	RIGHT ANGLE	BLACK	ON	MOM	1-2	2-3

THIS DRAWING IS A CONTROLLED DOCUMENT. 12-1-05

DWN	RAGHU	CHK	-	APVD	-	NAME	TE Connectivity		
PRODUCT SPEC	PUSHBUTTON SWITCH, TP SERIES			SIZE	A2	CAGE CODE	00779	DRAWING NO	C=1825095
APPLICATION SPEC	CUSTOMER DRAWING			WEIGHT	-	SCALE	4:1	SHEET	1 of 3
MATERIAL	FINISH			RESTRICTED TO	-				

1471-9 (3/11)

THIS DRAWING IS UNPUBLISHED. RELEASED FOR PUBLICATION  
 © COPYRIGHT - By - ALL RIGHTS RESERVED.

LOC	DIST	REVISIONS					
AD	00	P	LTR	DESCRIPTION	DATE	DWN	APVD
		-	-	SEE SHEET 1	-	-	-

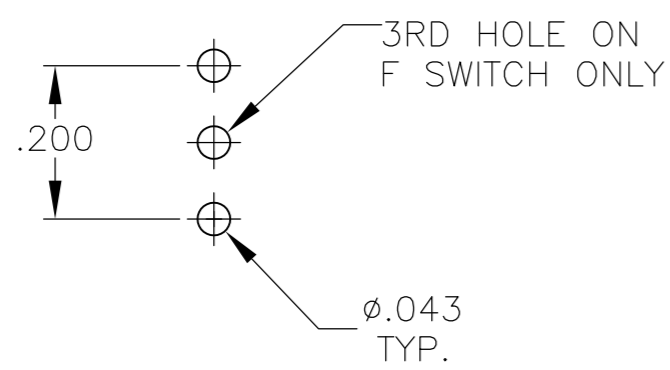

RECOMMENDED HOLE LAYOUT  
 TOLERANCE ±.002 UNLESS OTHERWISE NOTED

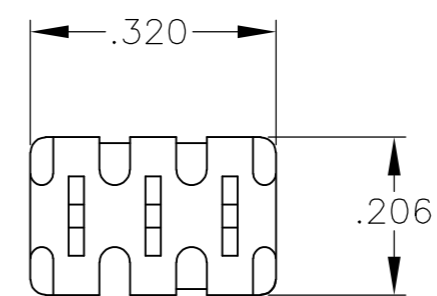
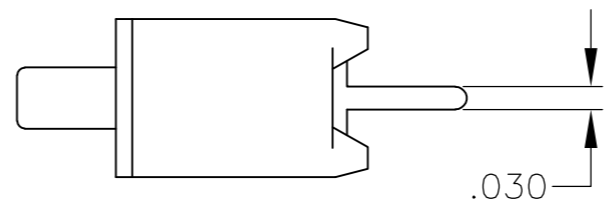
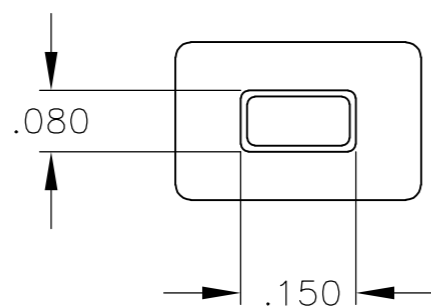
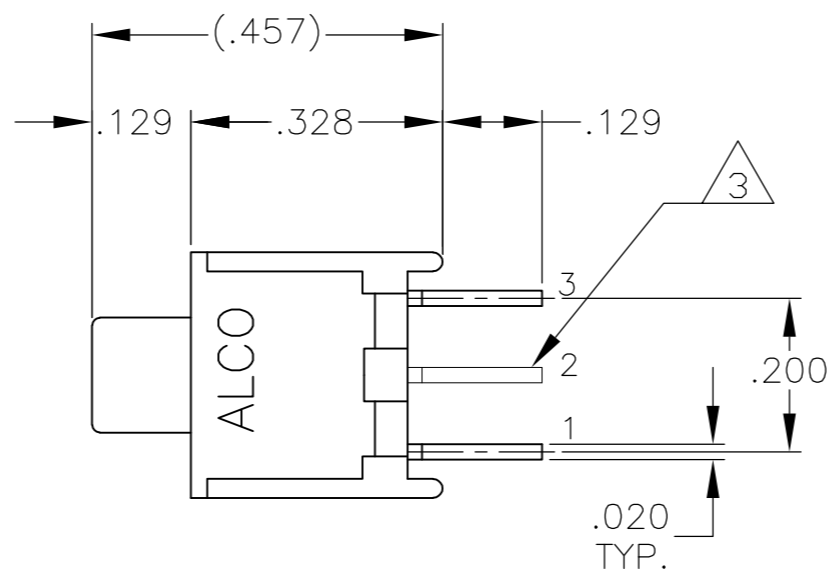

TP11CGPC  
 TP11FGPC

THIS DRAWING IS A CONTROLLED DOCUMENT.		DWN	12-1-05	<b>TE</b> TE Connectivity	
DIMENSIONS: INCHES		CHK	-		
TOLERANCES UNLESS OTHERWISE SPECIFIED:		APVD	-	NAME	
0 PLC ± -		PRODUCT SPEC	-	PUSHBUTTON SWITCH, TP SERIES	
1 PLC ± -		APPLICATION SPEC	-	SIZE	CAGE CODE
2 PLC ± -		WEIGHT	-	A2	00779
3 PLC ± .010		CUSTOMER DRAWING	-	DRAWING NO	1825095
4 PLC ± -		SCALE	4:1	SHEET	2 of 3
ANGLES ± 3°		REV	A2	RESTRICTED TO	
FINISH					

THIS DRAWING IS UNPUBLISHED. RELEASED FOR PUBLICATION  
 © COPYRIGHT - By - ALL RIGHTS RESERVED.

LOC		DIST		REVISIONS			
P	LTR	DESCRIPTION	DATE	DWN	APVD		
AD	00	SEE SHEET 1	-	-	-		

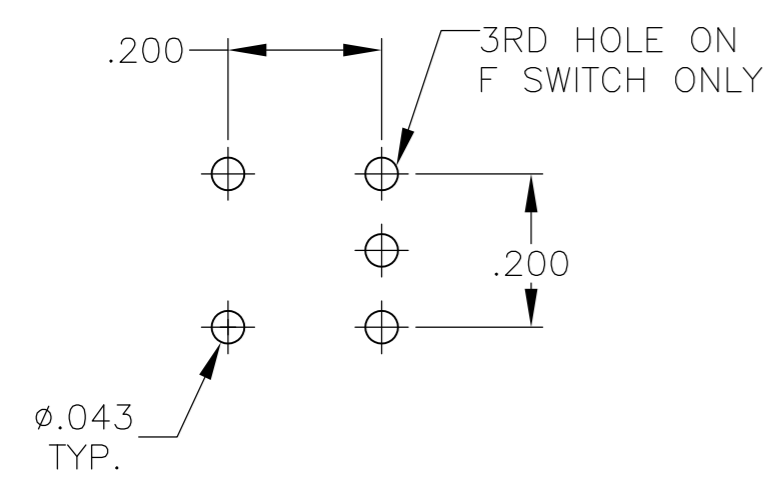

**RECOMMENDED HOLE LAYOUT**  
 TOLERANCE ±.002 UNLESS OTHERWISE NOTED

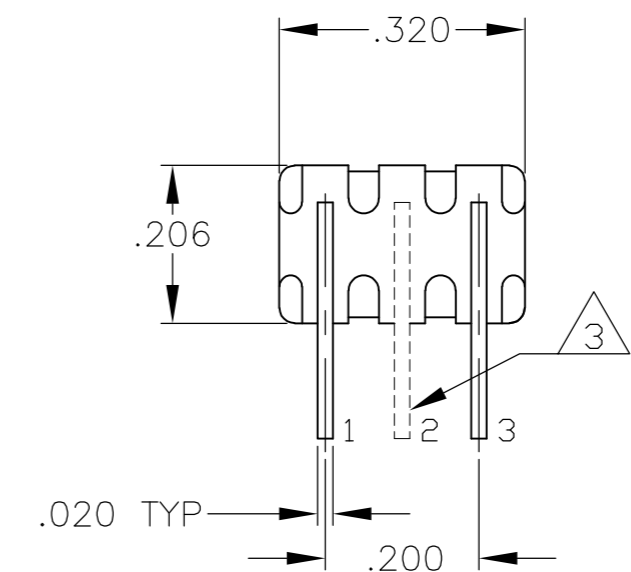
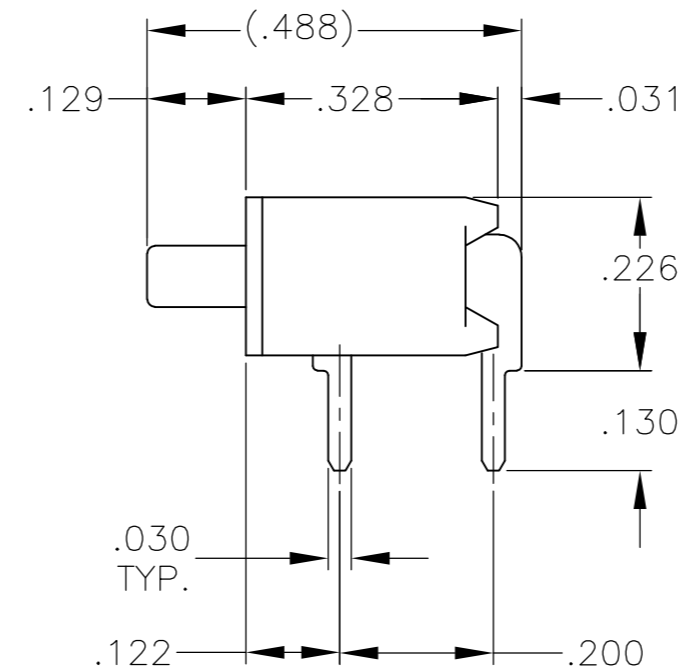
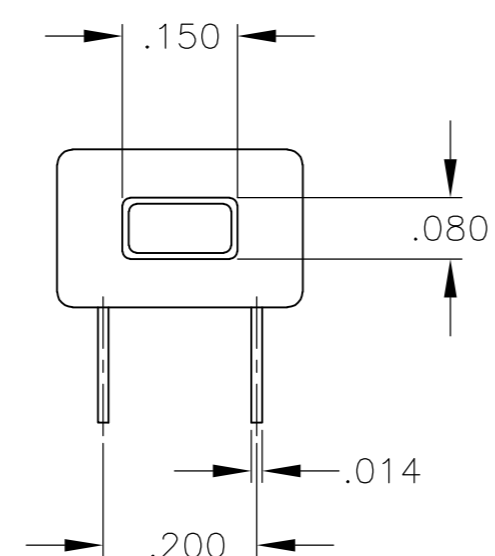

TP11CGRA  
 TP11FGRA

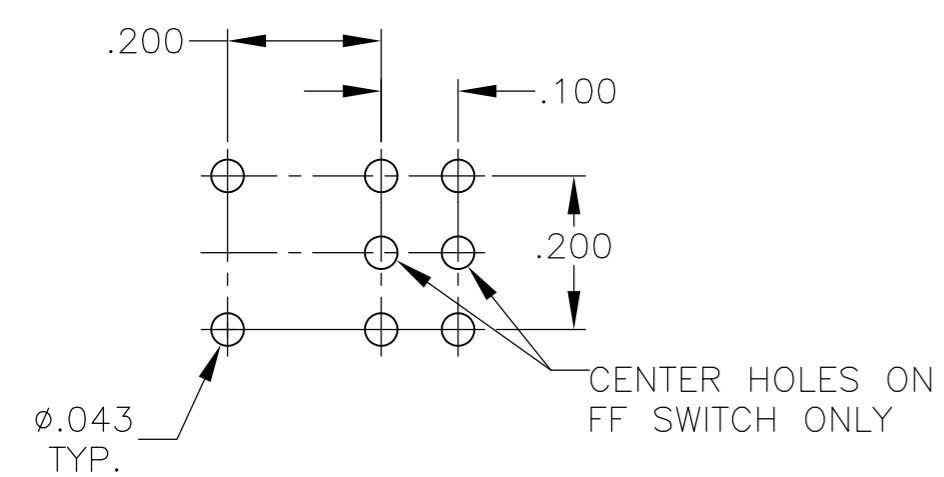

**RECOMMENDED HOLE LAYOUT**  
 TOLERANCE ±.002 UNLESS OTHERWISE NOTED

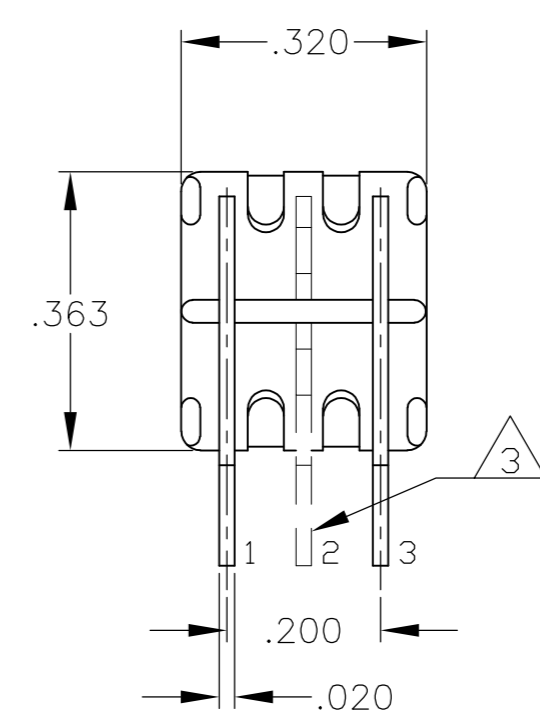
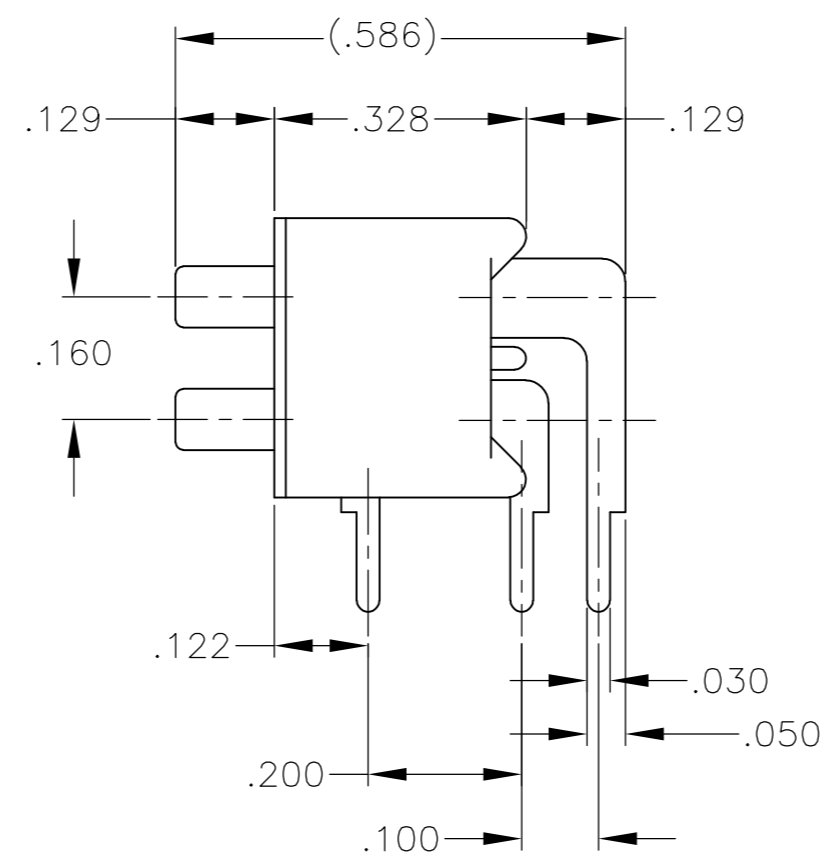
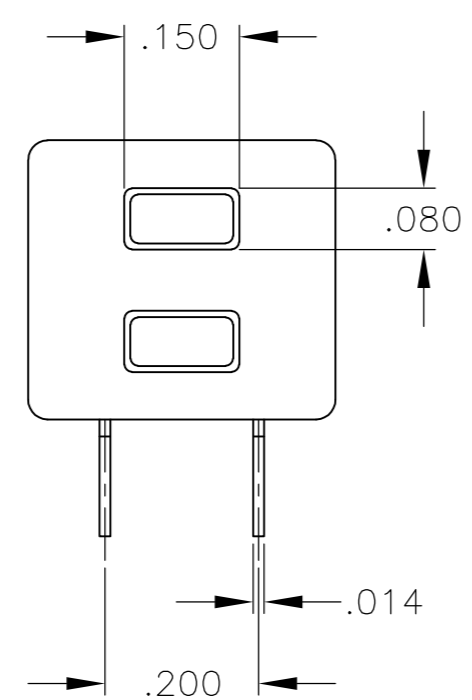

TP21CCGRA  
 TP21FFGRA

THIS DRAWING IS A CONTROLLED DOCUMENT.		DWN	12-1-05	<b>TE</b> TE Connectivity	
DIMENSIONS: INCHES		CHK	-		
TOLERANCES UNLESS OTHERWISE SPECIFIED:		APVD	-	NAME	
0 PLC ± -		PRODUCT SPEC	-	PUSHBUTTON SWITCH, TP SERIES	
1 PLC ± -		APPLICATION SPEC	-	SIZE	CAGE CODE
2 PLC ± -		WEIGHT	-	A2	00779
3 PLC ± .010		CUSTOMER DRAWING	-	DRAWING NO	1825095
4 PLC ± -		SCALE	1:1	SHEET	3 OF 3
ANGLES ± 3°		REV	A2	RESTRICTED TO	
FINISH					