

PI7C7300D
3-PORT PCI-to-PCI BRIDGE
Revision 1.01



3545 North 1ST Street, San Jose, CA 95134
Telephone: 1-877-PERICOM (1-877-737-4266)
FAX: 408-435-1100
Internet: <http://www.pericom.com>

LIFE SUPPORT POLICY

Pericom Semiconductor Corporation's products are not authorized for use as critical components in life support devices or systems unless a specific written agreement pertaining to such intended use is executed between the manufacturer and an officer of PSC.

1. Life support devices or systems are devices or systems which:

- a) are intended for surgical implant into the body or
- b) support or sustain life and whose failure to perform, when properly used in accordance with instructions for use provided in the labeling, can be reasonably expected to result in a significant injury to the user.

2. A critical component is any component of a life support device or system whose failure to perform can be reasonably expected to cause the failure of the life support device or system, or to affect its safety or effectiveness. Pericom Semiconductor Corporation reserves the right to make changes to its products or specifications at any time, without notice, in order to improve design or performance and to supply the best possible product. Pericom Semiconductor does not assume any responsibility for use of any circuitry described other than the circuitry embodied in a Pericom Semiconductor product. The Company makes no representations that circuitry described herein is free from patent infringement or other rights of third parties which may result from its use. No license is granted by implication or otherwise under any patent, patent rights or other rights, of Pericom Semiconductor Corporation.

All other trademarks are of their respective companies.

REVISION HISTORY

Revision	Date	Description
1.00	09/21/2004	Initial release of datasheet
1.01	11/21/2005	Removed "Advance Information" from datasheet Renamed pin Y4 from BYPASS to BY_PASS

This page intentionally left blank.

TABLE OF CONTENTS

1	INTRODUCTION	11
2	BLOCK DIAGRAM	12
3	SIGNAL DEFINITIONS	13
3.1	SIGNAL TYPES	13
3.2	PRIMARY BUS INTERFACE SIGNALS	13
3.3	SECONDARY BUS INTERFACE SIGNALS	15
3.4	CLOCK SIGNALS.....	17
3.5	MISCELLANEOUS SIGNALS	17
3.6	COMPACT PCI HOT-SWAP SIGNALS	17
3.7	JTAG BOUNDARY SCAN SIGNALS	18
3.8	POWER AND GROUND	18
3.9	PI7C7300D PBGA PIN LIST	18
4	PCI BUS OPERATION	21
4.1	TYPES OF TRANSACTIONS	21
4.2	SINGLE ADDRESS PHASE	22
4.3	DUAL ADDRESS PHASE	22
4.4	DEVICE SELECT (DEVSEL#) GENERATION	23
4.5	DATA PHASE	23
4.6	WRITE TRANSACTIONS	23
4.6.1	<i>MEMORY WRITE TRANSACTIONS</i>	24
4.6.2	<i>MEMORY WRITE AND INVALIDATE TRANSACTIONS</i>	25
4.6.3	<i>DELAYED WRITE TRANSACTIONS</i>	25
4.6.4	<i>WRITE TRANSACTION ADDRESS BOUNDARIES</i>	26
4.6.5	<i>BUFFERING MULTIPLE WRITE TRANSACTIONS</i>	26
4.6.6	<i>FAST BACK-TO-BACK WRITE TRANSACTIONS</i>	27
4.7	READ TRANSACTIONS.....	27
4.7.1	<i>PREFETCHABLE READ TRANSACTIONS</i>	27
4.7.2	<i>NON-PREFETCHABLE READ TRANSACTIONS</i>	27
4.7.3	<i>READ PREFETCH ADDRESS BOUNDARIES</i>	28
4.7.4	<i>DELAYED READ REQUESTS</i>	30
4.7.5	<i>DELAYED READ COMPLETION WITH TARGET</i>	30
4.7.6	<i>DELAYED READ COMPLETION ON INITIATOR BUS</i>	32
4.7.7	<i>FAST BACK-TO-BACK READ TRANSACTION</i>	32
4.8	CONFIGURATION TRANSACTIONS	33
4.8.1	<i>TYPE 0 ACCESS TO PI7C7300D</i>	33
4.8.2	<i>TYPE 1 TO TYPE 0 CONVERSION</i>	34
4.8.3	<i>TYPE 1 TO TYPE 1 FORWARDING</i>	35
4.8.4	<i>SPECIAL CYCLES</i>	36
4.9	TRANSACTION TERMINATION	37
4.9.1	<i>MASTER TERMINATION INITIATED BY PI7C7300D</i>	37
4.9.2	<i>MASTER ABORT RECEIVED BY PI7C7300D</i>	38
4.9.3	<i>TARGET TERMINATION RECEIVED BY PI7C7300D</i>	38
4.9.4	<i>TARGET TERMINATION INITIATED BY PI7C7300D</i>	41
4.10	CONCURRENT MODE OPERATION.....	42
5	ADDRESS DECODING	42

5.1	ADDRESS RANGES.....	43
5.2	I/O ADDRESS DECODING.....	43
5.2.1	<i>I/O BASE AND LIMIT ADDRESS REGISTER</i>	44
5.2.2	<i>ISA MODE</i>	45
5.3	MEMORY ADDRESS DECODING.....	45
5.3.1	<i>MEMORY-MAPPED I/O BASE AND LIMIT ADDRESS REGISTERS</i>	46
5.3.2	<i>PREFETCHABLE MEMORY BASE AND LIMIT ADDRESS REGISTERS</i>	47
5.4	VGA SUPPORT.....	48
5.4.1	<i>VGA MODE</i>	48
5.4.2	<i>VGA SNOOP MODE</i>	48
6	TRANSACTION ORDERING.....	49
6.1	TRANSACTIONS GOVERNED BY ORDERING RULES.....	49
6.2	GENERAL ORDERING GUIDELINES.....	50
6.3	ORDERING RULES.....	50
6.4	DATA SYNCHRONIZATION.....	52
7	ERROR HANDLING.....	52
7.1	ADDRESS PARITY ERRORS.....	52
7.2	DATA PARITY ERRORS.....	53
7.2.1	<i>CONFIGURATION WRITE TRANSACTIONS TO CONFIGURATION SPACE</i>	53
7.2.2	<i>READ TRANSACTIONS</i>	53
7.2.3	<i>DELAYED WRITE TRANSACTIONS</i>	54
7.2.4	<i>POSTED WRITE TRANSACTIONS</i>	56
7.3	DATA PARITY ERROR REPORTING SUMMARY.....	58
7.4	SYSTEM ERROR (SERR#) REPORTING.....	63
8	EXCLUSIVE ACCESS.....	63
8.1	CONCURRENT LOCKS.....	64
8.2	ACQUIRING EXCLUSIVE ACCESS ACROSS PI7C7300D.....	64
8.2.1	<i>LOCKED TRANSACTIONS IN DOWSTREAM DIRECTION</i>	64
8.2.2	<i>LOCKED TRANSACTION IN UPSTREAM DIRECTION</i>	65
8.3	ENDING EXCLUSIVE ACCESS.....	65
9	PCI BUS ARBITRATION.....	66
9.1	PRIMARY PCI BUS ARBITRATION.....	67
9.2	SECONDARY PCI BUS ARBITRATION.....	67
9.2.1	<i>SECONDARY BUSARBITRATION USING THE INTERNAL ARBITER</i>	67
9.2.2	<i>PREEMPTION</i>	69
9.2.3	<i>SECONDARY BUS ARBITRATION USING AN EXTERNAL ARBITER</i>	69
9.2.4	<i>BUS PARKING</i>	69
10	COMPACT PCI HOT SWAP.....	70
11	CLOCKS.....	70
11.1	PRIMARY CLOCK INPUTS.....	70
11.2	SECONDARY CLOCK OUTPUTS.....	70
12	RESET.....	71
12.1	PRIMARY INTERFACE RESET.....	71
12.2	SECONDARY INTERFACE RESET.....	71

13	SUPPORTED COMMANDS	72
13.1	PRIMARY INTERFACE.....	72
13.2	SECONDARY INTERFACE.....	73
14	CONFIGURATION REGISTERS	73
14.1	CONFIGURATION REGISTER 1 AND 2.....	75
14.1.1	VENDOR ID REGISTER – OFFSET 00h.....	75
14.1.2	DEVICE ID REGISTER – OFFSET 00h.....	76
14.1.3	COMMAND REGISTER – OFFSET 04h.....	76
14.1.4	STATUS REGISTER – OFFSET 04h.....	77
14.1.5	REVISION ID REGISTER – OFFSET 08h.....	78
14.1.6	CLASS CODE REGISTER – OFFEST 08h.....	78
14.1.7	CACHE LINE SIZE REGISTER – OFFSET 0Ch.....	78
14.1.8	PRIMARY LATENCY TIMER REGISTER – OFFSET 0Ch.....	78
14.1.9	HEADER TYPE REGISTER – OFFSET 0Ch.....	79
14.1.10	PRIMARY BUS NUMBER REGISTER – OFFSET 18h.....	79
14.1.11	SECONDARY (S1 or S2) BUS NUMBER REGISTER – OFFSET 18h.....	79
14.1.12	SUBORDINATE (S1 or S2) BUS NUMBER REGISTER – OFFSET 18h.....	79
14.1.13	SECONDARY LATENCY TIMER REGISTER – OFFSET 18h.....	79
14.1.14	I/O BASE REGISTER – OFFSET 1Ch.....	80
14.1.15	I/O LIMIT REGISTER – OFFSET 1Ch.....	80
14.1.16	SECONDARY STATUS REGISTER – OFFSET 1Ch.....	80
14.1.17	MEMORY BASE REGISTER – OFFSET 20h.....	81
14.1.18	MEMORY LIMIT REGISTER – OFFSET 20h.....	81
14.1.19	PREFETCHABLE MEMORY BASE REGISTER – OFFSET 24h.....	82
14.1.20	PREFETCHABLE MEMORY LIMIT REGISTER – OFFSET 24h.....	82
14.1.21	PREFETCHABLE MEMORY BASE ADDRESS UPPER 32-BITS REGISTER – OFFSET 28h.....	82
14.1.22	PREFETCHABLE MEMORY LIMIT ADDRESS UPPER 32-BITS REGISTER – OFFSET 2Ch.....	82
14.1.23	I/O BASE ADDRESS UPPER 16-BITS REGISTER – Offset 30h.....	83
14.1.24	I/O LIMIT ADDRESS UPPER 16-BITS REGISTER – OFFSET 30h.....	83
14.1.25	ECP POINTER REGISTER – OFFSET 34h.....	83
14.1.26	BRIDGE CONTROL REGISTER – OFFSET 3Ch.....	83
14.1.27	DIAGNOSTIC / CHIP CONTROL REGISTER – OFFSET 40h.....	85
14.1.28	ARBITER CONTROL REGISTER – OFFSET 40h.....	86
14.1.29	UPSTREAM MEMORY CONTROL REGISTER – OFFSET 48h.....	86
14.1.30	HOT SWAP SWITCH TIME SLOT REGISTER – OFFSET 4Ch.....	86
14.1.31	UPSTREAM (S1 or S2 to P) MEMORY BASE REGISTER – OFFSET 50h.....	87
14.1.32	UPSTREAM (S1 or S2 to P) MEMORY LIMIT REGISTER – OFFSET 50h.....	87
14.1.33	UPSTREAM (S1 or S2 to P) MEMORY BASE UPPER 32-BITS REGISTER – OFFSET 54h.....	87
14.1.34	UPSTREAM (S1 or S2 to P) MEMORY LIMIT UPPER 32 BITS REGISTER – OFFSET 58h.....	88
14.1.35	P_SERR# EVENT DISABLE REGISTER – OFFSET 64h.....	88
14.1.36	SECONDARY CLOCK CONTROL REGISTER – OFFSET 68h.....	89
14.1.37	PORT OPTION REGISTER – OFFSET 74h.....	89
14.1.38	MASTER TIMEOUT COUNTER REGISTER – OFFSET 74h.....	91
14.1.39	RETRY COUNTER REGISTER – OFFSET 78h.....	91
14.1.40	SAMPLING TIMER REGISTER – OFFSET 7Ch.....	91
14.1.41	SECONDARY SUCCESSFUL I/O READ COUNTER REGISTER – OFFSET 80h.....	91

14.1.42	SECONDARY SUCCESSFUL I/O WRITE COUNTER REGISTER – OFFSET 84h.....	91
14.1.43	SECONDARY SUCCESSFUL MEMORY READ COUNTER REGISTER – Offset 88h	92
14.1.44	SECONDARY SUCCESSFUL MEMORY WRITE COUNTER REGISTER – OFFSET 8Ch	92
14.1.45	PRIMARY SUCCESSFUL I/O READ COUNTER REGISTER – OFFSET 90h	92
14.1.46	PRIMARY SUCCESSFUL I/O WRITE COUNTER REGISTER – OFFSET 94h.....	92
14.1.47	PRIMARY SUCCESSFUL MEMORY READ COUNTER REGISTER – OFFSET 98h..	92
14.1.48	PRIMARY SUCCESSFUL MEMORY WRITE COUNTER REGISTER – OFFSET 9Ch	93
14.1.49	CAPABILITY ID REGISTER – OFFSET B0h.....	93
14.1.50	NEXT POINTER REGISTER – OFFSET B0h.....	93
14.1.51	SLOT NUMBER REGISTER – OFFSET B0h.....	93
14.1.52	CHASSIS NUMBER REGISTER – OFFSET B0h.....	93
14.1.53	CAPABILITY ID REGISTER – OFFSET C0h.....	94
14.1.54	NEXT POINTER REGISTER – OFFSET C0h.....	94
14.1.55	HOT SWAP CONTROL AND STATUS REGISTER – OFFSET C0h.....	94
15	BRIDGE BEHAVIOR.....	94
15.1	BRIDGE ACTIONS FOR VARIOUS CYCLE TYPES	95
15.2	TRANSACTION ORDERING	95
15.3	ABNORMAL TERMINATION (INITIATED BY BRIDGE MASTER)	96
15.3.1	MASTER ABORT.....	96
15.3.2	PARITY AND ERROR REPORTING.....	96
15.3.3	REPORTING PARITY ERRORS.....	96
15.3.4	SECONDARY IDSEL MAPPING	97
16	IEEE 1149.1 COMPATIBLE JTAG CONTROLLER	97
16.1	BOUNDARY SCAN ARCHITECTURE	97
16.1.1	TAP PINS.....	98
16.1.2	INSTRUCTION REGISTER.....	98
16.2	BOUNDARY-SCAN INSTRUCTION SET.....	99
16.3	TAP TEST DATA REGISTERS.....	99
16.4	BYPASS REGISTER.....	100
16.5	BOUNDARY-SCAN REGISTER	100
16.6	TAP CONTROLLER	100
17	ELECTRICAL AND TIMING SPECIFICATIONS.....	103
17.1	MAXIMUM RATINGS	103
17.2	3.3V DC SPECIFICATIONS.....	104
17.3	3.3V AC SPECIFICATIONS.....	105
17.4	PRIMARY AND SECONDARY BUSES AT 66MHz CLOCK TIMING	106
17.5	PRIMARY AND SECONDARY BUSES AT 33MHz CLOCK TIMING	106
17.6	POWER CONSUMPTION	106
18	272-PIN PBGA PACKAGE FIGURE	107
18.1	PART NUMBER ORDERING INFORMATION	107

LIST OF TABLES

TABLE 4-1 PCI TRANSACTIONS	21
TABLE 4-2 WRITE TRANSACTION FORWARDING	23
TABLE 4-3 WRITE TRANSACTION DISCONNECT ADDRESS BOUNDARIES	26
TABLE 4-4 READ PREFETCH ADDRESS BOUNDARIES	29
TABLE 4-5 READ TRANSACTION PREFETCHING	30
TABLE 4-6 DEVICE NUMBER TO IDSEL S1_AD OR S2_AD PIN MAPPING	34
TABLE 4-7 DELAYED WRITE TARGET TERMINATION RESPONSE	39
TABLE 4-8 RESPONSE TO POSTED WRITE TARGET TERMINATION	39
TABLE 4-9 RESPONSE TO DELAYED READ TARGET TERMINATION	40
TABLE 6-1 SUMMARY OF TRANSACTION ORDERING	50
TABLE 7-1 SETTING THE PRIMARY INTERFACE DETECTED PARITY ERROR BIT	58
TABLE 7-2 SETTING SECONDARY INTERFACE DETECTED PARITY ERROR BIT	58
TABLE 7-3 SETTING PRIMARY INTERFACE DATA PARITY ERROR DETECTED BIT	59
TABLE 7-4 SETTING SECONDARY INTERFACE DATA PARITY ERROR DETECTED BIT	59
TABLE 7-5 ASSERTION OF P_PERR#	60
TABLE 7-6 ASSERTION OF S_PERR#	62
TABLE 7-7 ASSERTION OF P_SERR# FOR DATA PARITY ERRORS	62
TABLE 16-1 TAP PINS	99
TABLE 16-2 JTAG BOUNDARY REGISTER ORDER	101

LIST OF FIGURES

FIGURE 9-1 SECONDARY ARBITER EXAMPLE	68
FIGURE 16-1 TEST ACCESS PORT BLOCK DIAGRAM	98
FIGURE 17-1 PCI SIGNAL TIMING MEASUREMENT CONDITIONS	105
FIGURE 18-1 272-PIN PBGA PACKAGE	107

This page intentionally left blank.

1 INTRODUCTION

PRODUCT DESCRIPTION

The PI7C7300D is Pericom Semiconductor's second-generation PCI-PCI Bridge and is an updated revision to the PI7C7300A. It is designed to be fully compliant with the 32-bit, 66MHz implementation of the *PCI Local Bus Specification, Revision 2.2*. The PI7C7300D supports only synchronous bus transactions between devices on the Primary Bus running at 33MHz to 66MHz and the Secondary Buses operating at either 33MHz or 66MHz. The Primary and Secondary Buses can also operate in concurrent mode, resulting in added increase in system performance. Concurrent bus operation off-loads and isolates unnecessary traffic from the Primary Bus; thereby enabling a master and a target device on the same Secondary PCI Bus to communicate even while the Primary Bus is busy. In addition, the Secondary Buses have load balancing capability, allowing faster devices to be isolated away from slower devices. Among the other features supported by the PI7C7300D are: support for up to 15 devices on the Secondary Buses, Compact PCI Hot Swap (PICMG 2.1, R1.0) *Friendly* Support and Dual Addressing Cycle.

PRODUCT FEATURES

- 32-bit Primary and Two Secondary Ports run up to 66MHz
- All 3 ports compliant with the *PCI Local Bus Specification, Revision 2.2*
- Compliant with PCI-to-PCI Bridge Architecture Specification, Revision 1.1.
 - All I/O and memory commands
 - Type 1 to Type 0 configuration conversion
 - Type 1 to Type 1 configuration forwarding
 - Type 1 configuration write to special cycle conversion
- Concurrent Primary to Secondary Bus operation and independent intra-Secondary Port channel to reduce traffic on the Primary Port
- Provides internal arbitration for one set of eight secondary bus masters (S1 bus) and one set of seven (eight if Hot Swap is disabled) secondary bus masters (S2 bus)
 - Programmable 2-level priority arbiter
 - Disable control for use of external arbiter
- Supports posted write buffers in all directions
- Three 128 byte FIFO's for delay transactions
- Three 128 byte FIFO's for posted memory transactions
- Enhanced address decoding
 - 32-bit I/O address range
 - 32-bit memory-mapped I/O address range
 - VGA addressing and VGA palette snooping
 - ISA-aware mode for legacy support in the first 64KB of I/O address range
- Dual Addressing cycle (64-bit)
- Supports system transaction ordering rules
- Tri-state control of output buffers on secondary buses
- Compact PCI Hot Swap (PICMG 2.1, R1.0) *Friendly* Support
- Industrial Temperature range -40°C to 85°C
- IEEE 1149.1 JTAG interface support
- 3.3V core; 3.3V PCI I/O interface with 5V I/O tolerance
- 272-pin plastic BGA package

2 BLOCK DIAGRAM

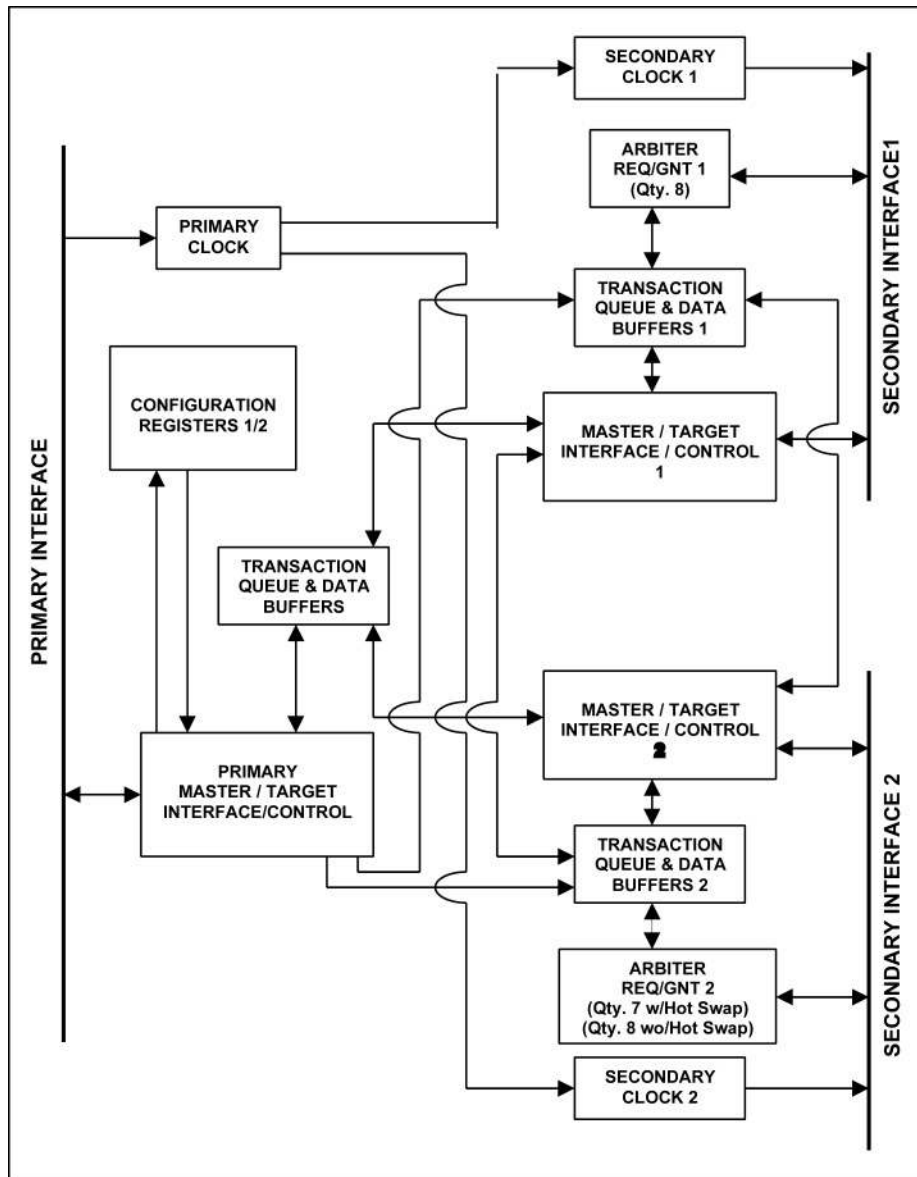

3 SIGNAL DEFINITIONS

3.1 SIGNAL TYPES

Signal Type	Description
PI	PCI input (3.3V, 5V tolerant)
PIU	PCI input (3.3V, 5V tolerant) with weak pull-up
PID	PCI input (3.3V, 5V tolerant) with weak pull-down
PO	PCI output (3.3V)
PB	PCI tri-state bidirectional (3.3V, 5V tolerant)
PSTS	PCI sustained tri-state bi-directional (Active LOW signal which must be driven inactive for one cycle before being tri-stated to ensure HIGH performance on a shared signal line)
PTS	PCI tri-state output
POD	PCI output which either drives LOW (active state) or tri-state

3.2 PRIMARY BUS INTERFACE SIGNALS

Name	Pin #	Type	Description
P_AD[31:0]	Y7, W7, Y8, W8, V8, U8, Y9, W9, W10, V10, Y11, V11, U11, Y12, W12, V12, V16, W16, Y16, W17, Y17, U18, W18, Y18, U19, W19, Y19, U20, V20, Y20, T17, R17	PB	Primary Address/Data. Multiplexed address and data bus. Address is indicated by P_FRAME# assertion. Write data is stable and valid when P_IRDY# is asserted and read data is stable and valid when P_TRDY# is asserted. Data is transferred on rising clock edges when both P_IRDY# and P_TRDY# are asserted. During bus idle, PI7C7300D drives P_AD to a valid logic level when P_GNT# is asserted.
P_CBE[3:0]	V9, U12, U16, V19	PB	Primary Command/Byte Enables. Multiplexed command field and byte enable field. During address phase, the initiator drives the transaction type on these pins. The initiator then drives the byte enables during data phases. During bus idle, PI7C7300D drives P_CBE[3:0] to a valid logic level when P_GNT# is asserted.
P_PAR	U15	PB	Primary Parity. Parity is even across P_AD[31:0], P_CBE[3:0], and P_PAR (i.e. an even number of 1's). P_PAR is an input and is valid and stable one cycle after the address phase (indicated by assertion of P_FRAME#) for address parity. For write data phases, P_PAR is an input and is valid one clock after P_IRDY# is asserted. For read data phase, P_PAR is an output and is valid one clock after P_TRDY# is asserted. Signal P_PAR is tri-stated one cycle after the P_AD lines are tri-stated. During bus idle, PI7C7300D drives P_PAR to a valid logic level when P_GNT# is asserted.
P_FRAME#	W13	PSTS	Primary FRAME (Active LOW). Driven by the initiator of a transaction to indicate the beginning and duration of an access. The de-assertion of P_FRAME# indicates the final data phase requested by the initiator. Before being tri-stated, it is driven to a de-asserted state for one cycle.

Name	Pin #	Type	Description
P_IRDY#	V13	PSTS	Primary IRDY (Active LOW). Driven by the initiator of a transaction to indicate its ability to complete current data phase on the primary side. Once asserted in a data phase, it is not de-asserted until the end of the data phase. Before tri-stated, it is driven to a de-asserted state for one cycle.
P_TRDY#	U13	PSTS	Primary TRDY (Active LOW). Driven by the target of a transaction to indicate its ability to complete current data phase on the primary side. Once asserted in a data phase, it is not de-asserted until the end of the data phase. Before tri-stated, it is driven to a de-asserted state for one cycle.
P_DEVSEL#	Y14	PSTS	Primary Device Select (Active LOW). Asserted by the target indicating that the device is accepting the transaction. As a master, PI7C7300D waits for the assertion of this signal within 5 cycles of P_FRAME# assertion; otherwise, terminate with master abort. Before tri-stated, it is driven to a de-asserted state for one cycle.
P_STOP#	W14	PSTS	Primary STOP (Active LOW). Asserted by the target indicating that the target is requesting the initiator to stop the current transaction. Before tri-stated, it is driven to a de-asserted state for one cycle.
P_LOCK#	V14	PSTS	Primary LOCK (Active LOW). Asserted by the master for multiple transactions to complete.
P_IDSEL	Y10	PI	Primary ID Select. Used as a chip select line for Type 0 configuration accesses to PI7C7300D configuration space.
P_PERR#	Y15	PSTS	Primary Parity Error (Active LOW). Asserted when a data parity error is detected for data received on the primary interface. Before being tri-stated, it is driven to a de-asserted state for one cycle.
P_SERR#	W15	POD	Primary System Error (Active LOW). Can be driven LOW by any device to indicate a system error condition. PI7C7300D drives this pin on: <ul style="list-style-type: none"> ▪ Address parity error ▪ Posted write data parity error on target bus ▪ Secondary S1_SERR# or S2_SERR# asserted ▪ Master abort during posted write transaction ▪ Target abort during posted write transaction ▪ Posted write transaction discarded ▪ Delayed write request discarded ▪ Delayed read request discarded ▪ Delayed transaction master timeout This signal requires an external pull-up resistor for proper operation.
P_REQ#	W6	PTS	Primary Request (Active LOW). This is asserted by PI7C7300D to indicate that it wants to start a transaction on the primary bus. PI7C7300D de-asserts this pin for at least 2 PCI clock cycles before asserting it again.
P_GNT#	U7	PI	Primary Grant (Active LOW). When asserted, PI7C7300D can access the primary bus. During idle and P_GNT# asserted, PI7C7300D will drive P_AD, P_CBE, and P_PAR to valid logic levels.
P_RESET#	Y5	PI	Primary RESET (Active LOW). When P_RESET# is active, all PCI signals should be asynchronously tri-stated.

Name	Pin #	Type	Description
P_M66EN	V18	PI	Primary Interface 66MHz Operation. This input is used to specify if PI7C7300D is capable of running at 66MHz. For 66MHz operation on the Primary bus, this signal should be pulled "HIGH". For 33MHz operation on the Primary bus, this signal should be pulled "LOW". In this condition, S1_M66EN and S2_M66EN will both need to be "LOW", forcing both secondary buses to run at 33MHz also.

3.3 SECONDARY BUS INTERFACE SIGNALS

Name	Pin #	Type	Description
S1_AD[31:0], S2_AD[31:0]	B20, B19, C20, C19, C18, D20, D19, D17, E19, E18, E17, F20, F19, F17, G20, G19, L20, L19, L18, M20, M19, M17, N20, N19, N18, N17, P17, R20, R19, R18, T20, T19 J4, H1, H2, H3, H4, G1, G3, G4, F2, F3, F4, E1, E4, D1, C1, B1, C5, B5, D6, C6, B6, A6, C7, B7, D8, C8, D9, C9, B9, A9, D10, C10	PB	Secondary Address/Data. Multiplexed address and data bus. Address is indicated by S1_FRAME# or S2_FRAME# assertion. Write data is stable and valid when S1_IRDY# or S2_IRDY# is asserted and read data is stable and valid when S1_IRDY# or S2_IRDY# is asserted. Data is transferred on rising clock edges when both S1_IRDY# or S2_IRDY# and S1_TRDY# or S2_TRDY# are asserted. During bus idle, PI7C7300D drives S1_AD or S2_AD to a valid logic level when S1_GNT# or S2_GNT# is asserted respectively.
S1_CBE[3:0], S2_CBE[3:0]	E20, G18, K17, P20 F1, A1, A4, A7	PB	Secondary Command/Byte Enables. Multiplexed command field and byte enable field. During address phase, the initiator drives the transaction type on these pins. The initiator then drives the byte enables during data phases. During bus idle, PI7C7300D drives S1_CBE[3:0] or S2_CBE[3:0] to a valid logic level when the internal grant is asserted.
S1_PAR, S2_PAR	K18, B4	PB	Secondary Parity. Parity is even across S1_AD[31:0], S1_CBE[3:0], and S1_PAR or S2_AD[31:0], S2_CBE[3:0], and S2_PAR (i.e. an even number of 1's). S1_PAR or S2_PAR is an input and is valid and stable one cycle after the address phase (indicated by assertion of S1_FRAME# or S2_FRAME#) for address parity. For write data phases, S1_PAR or S2_PAR is an input and is valid one clock after S1_IRDY# or S2_IRDY# is asserted. For read data phase, S1_PAR or S2_PAR is an output and is valid one clock after S1_TRDY# or S2_TRDY# is asserted. Signal S1_PAR or S2_PAR is tri-stated one cycle after the S1_AD or S2_AD lines are tri-stated. During bus idle, PI7C7300D drives S1_PAR or S2_PAR to a valid logic level when the internal grant is asserted.
S1_FRAME#, S2_FRAME#	H20, D2	PSTS	Secondary FRAME (Active LOW). Driven by the initiator of a transaction to indicate the beginning and duration of an access. The de-assertion of S1_FRAME# or S2_FRAME# indicates the final data phase requested by the initiator. Before being tri-stated, it is driven to a de-asserted state for one cycle.

Name	Pin #	Type	Description
S1_IRDY#, S2_IRDY#	H19, B2	PSTS	Secondary IRDY (Active LOW). Driven by the initiator of a transaction to indicate its ability to complete current data phase on the secondary side. Once asserted in a data phase, it is not de-asserted until the end of the data phase. Before tri-stated, it is driven to a de-asserted state for one cycle.
S1_TRDY#, S2_TRDY#	H18, A2	PSTS	Secondary TRDY (Active LOW). Driven by the target of a transaction to indicate its ability to complete current data phase on the secondary side. Once asserted in a data phase, it is not de-asserted until the end of the data phase. Before tri-stated, it is driven to a de-asserted state for one cycle.
S1_DEVSEL#, S2_DEVSEL#	J20, D3	PSTS	Secondary Device Select (Active LOW). Asserted by the target indicating that the device is accepting the transaction. As a master, PI7C7300D waits for the assertion of this signal within 5 cycles of S1_FRAME# or S2_FRAME# assertion; otherwise, terminate with master abort. Before tri-stated, it is driven to a de-asserted state for one cycle.
S1_STOP#, S2_STOP#	J19, C3	PSTS	Secondary STOP (Active LOW). Asserted by the target indicating that the target is requesting the initiator to stop the current transaction. Before tri-stated, it is driven to a de-asserted state for one cycle.
S1_LOCK#, S2_LOCK#	J18, B3	PSTS	Secondary LOCK (Active LOW). Asserted by the master for multiple transactions to complete.
S1_PERR#, S2_PERR#	J17, D4	PSTS	Secondary Parity Error (Active LOW). Asserted when a data parity error is detected for data received on the secondary interface. Before being tri-stated, it is driven to a de-asserted state for one cycle.
S1_SERR#, S2_SERR#	K20, C4	PI	Secondary System Error (Active LOW). Can be driven LOW by any device to indicate a system error condition.
S1_REQ#[7:0], S2_REQ#[6:0]	B11, A12, D13, C13, C15, A16, C17, B17 R3, P2, P1, M2, M1, K1, K3	PIU	Secondary Request (Active LOW). This is asserted by an external device to indicate that it wants to start a transaction on the secondary bus. The input is externally pulled up through a resistor to VDD.
S1_GNT#[7:0] S2_GNT#[6:0]	C11, B12, B13, A14, D14, B16, D16, B18 P4, R1, N4, M3, L4, L1, K2	PO	Secondary Grant (Active LOW). PI7C7300D asserts this pin to access the secondary bus. PI7C7300D de-asserts this pin for at least 2 PCI clock cycles before asserting it again. During idle and S1_GNT# or S2_GNT# asserted, PI7C7300D will drive S1_AD, S1_CBE, and S1_PAR or S2_AD, S2_CBE, and S2_PAR.
S1_RESET#, S2_RESET#	B10, T4	PO	Secondary RESET (Active LOW). Asserted when any of the following conditions are met: <ol style="list-style-type: none"> Signal P_RESET# is asserted. Secondary reset bit in bridge control register in configuration space is set. When asserted, all control signals are tri-stated and zeroes are driven on S1_AD, S1_CBE, and S1_PAR or S2_AD, S2_CBE, and S2_PAR.
S1_EN, S2_EN	W3, W4	PIU	Secondary Enable (Active HIGH). When S1_EN or S2_EN is inactive, secondary bus PCI S1 or PCI S2 will be asynchronously tri-stated.
S1_M66EN, S2_M66EN	D7, W5	PI	Secondary Interface 66MHz Operation. This input is used to specify if PI7C7300D is capable of running at 66MHz on the secondary side. When HIGH, the S1 or S2 bus may run at 66MHz. When LOW, the S1 or S2 bus may only run at 33MHz. If P_M66EN is pulled LOW, both S1_M66EN and S2_M66EN need to be LOW.

Name	Pin #	Type	Description
S_CFN#	Y2	PIU	Secondary Bus Central Function Control Pin. When tied LOW, it enables the internal arbiter. When tied HIGH, an external arbiter must be used. S1_REQ#[0] or S2_REQ#[0] is reconfigured to be the secondary bus grant input, and S1_GNT#[0] or S2_GNT#[0] is reconfigured to be the secondary bus request output.

3.4 CLOCK SIGNALS

Name	Pin #	Type	Description
P_CLK	V6	PI	Primary Clock Input. Provides timing for all transactions on the primary interface.
S1_CLKOUT [7:0]	A11, C12, A13, B14, B15, C16, A18, A19	PTS	Secondary Clock Output. Provides secondary 1 clocks phase synchronous with the P_CLK.
S2_CLKOUT [7:0]	T3, T1, P3, N3, M4, L3, L2, J1	PTS	Secondary Clock Output. Provides secondary 2 clocks phase synchronous with the P_CLK.

3.5 MISCELLANEOUS SIGNALS

Name	Pin #	Type	Description
BY_PASS	Y4	PI	Reserved. Reserved for future use. Must be tied HIGH.
PLL_TM	Y3	PI	Reserved. Reserved for future use. Must be tied LOW.
S_CLKIN	V5	PI	Reserved. Reserved for future use. Must be tied LOW.
SCAN_TM#	V4	PI	Full-Scan Test Mode Enable (Active LOW). Connect HIGH for normal operation. When SCAN_TM# is active, the ten scan chains will be enabled. The scan clock is P_CLK. The scan input and outputs are as follows: S1_REQ[6], S1_REQ[5], S1_REQ[4], S1_REQ[3], S1_REQ[2], S2_REQ#[6], S2_REQ#[5], S2_REQ#[4], S2_REQ#[3], S2_REQ#[2], and S1_GNT#[6], S1_GNT#[5], S1_GNT#[4], S1_GNT#[3], S1_GNT#[2], S2_GNT#[6], S2_GNT#[5], S2_GNT#[4], S2_GNT#[3], S2_GNT#[2]
SCAN_EN	U5	PID	Full-Scan Enable Control. SCAN_EN should be tied LOW in normal mode. When SCAN_EN is LOW, full-scan is in shift operation if SCAN_TM# is active. When SCAN_EN is HIGH, full-scan is in parallel operation if SCAN_TM# is active.

3.6 COMPACT PCI HOT-SWAP SIGNALS

Name	Pin #	Type	Description
LOO	U1	PO	Hot Swap LED. The output of this pin lights a blue LED to indicate insertion and removal ready status. If HS_EN is LOW, pin is S2_GNT#[7].
HS_SW#	T2	PI	Hot Swap Switch. When driven LOW, this signal indicates that the board ejector handle indicates an insertion or impending extraction of a board. If HS_EN is LOW, pin is S2_REQ#[7].

Name	Pin #	Type	Description
HS_EN	U6	PI	Hot Swap Enable. To enable Hot Swap Friendly support, this signal should be pulled HIGH.
ENUM#	R4	POD	Hot Swap Status Indicator. The output of ENUM# indicates to the system that an insertion has occurred of that an extraction is about to occur.

3.7 JTAG BOUNDARY SCAN SIGNALS

Name	Pin #	Type	Description
TCK	V2	PIU	Test Clock. Used to clock state information and data into and out of the PI7C7300D during boundary scan.
TMS	W1	PIU	Test Mode Select. Used to control the state of the Test Access Port controller.
TDO	V3	PTS	Test Data Output. When SCAN_EN is HIGH, it is used (in conjunction with TCK) to shift data out of the Test Access Port (TAP) in a serial bit stream.
TDI	W2	PIU	Test Data Input. When SCAN_EN is HIGH, it is used (in conjunction with TCK) to shift data and instructions into the Test Access Port (TAP) in a serial bit stream.
TRST#	U3	PIU	Test Reset. Active LOW signal to reset the Test Access Port (TAP) controller into an initialized state.

3.8 POWER AND GROUND

Name	Pin #	Type	Description
VDD	B8, C14, D5, D11, D15, E2, F18, J3, L17, N2, P19, U10, V1, V7, V15, W20		3.3V Digital Power
VSS	A3, A5, A8, A10, A15, A17, A20, C2, D12, D18, E3, G2, G17, H17, J2, J9, J10, J11, J12, K4, K9, K10, K11, K12, K19, L9, L10, L11, L12, M9, M10, M11, M12, M18, N1, P18, R2, T18, U2, U9, U14, U17, V17, W11, Y6, Y13		Digital Ground
AVCC	Y1		Analog 3.3V for PLL
AGND	U4		Analog Ground for PLL

3.9 PI7C7300D PBGA PIN LIST

Pin #	Name	Type	Pin #	Name	Type
A1	S2_CBE[2]	PB	A2	S2_TRDY#	PSTS
A3	VSS	-	A4	S2_CBE[1]	PB
A5	VSS	-	A6	S2_AD[10]	PB

Pin #	Name	Type	Pin #	Name	Type
A7	S2_CBE[0]	PB	A8	VSS	-
A9	S2_AD[2]	PB	A10	VSS	-
A11	S1_CLKOUT[7]	PTS	A12	S1_REQ#[6]	PIU
A13	S1_CLKOUT[5]	PTS	A14	S1_GNT#[4]	PO
A15	VSS	-	A16	S1_REQ#[2]	PIU
A17	VSS	-	A18	S1_CLKOUT[1]	PTS
A19	S1_CLKOUT[0]	PTS	A20	VSS	-
B1	S2_AD[16]	PB	B2	S2_IRDY#	PSTS
B3	S2_LOCK#	PSTS	B4	S2_PAR	PB
B5	S2_AD[14]	PB	B6	S2_AD[11]	PB
B7	S2_AD[8]	PB	B8	VDD	-
B9	S2_AD[3]	PB	B10	S1_RESET#	PO
B11	S1_REQ#[7]	PIU	B12	S1_GNT#[6]	PO
B13	S1_GNT#[5]	PO	B14	S1_CLKOUT[4]	PTS
B15	S1_CLKOUT[3]	PTS	B16	S1_GNT#[2]	PO
B17	S1_REQ#[0]	PIU	B18	S1_GNT#[0]	PO
B19	S1_AD[30]	PB	B20	S1_AD[31]	PB
C1	S2_AD[17]	PB	C2	VSS	-
C3	S2_STOP#	PSTS	C4	S2_SERR#	PI
C5	S2_AD[15]	PB	C6	S2_AD[12]	PB
C7	S2_AD[9]	PB	C8	S2_AD[6]	PB
C9	S2_AD[4]	PB	C10	S2_AD[0]	PB
C11	S1_GNT#[7]	PO	C12	S1_CLKOUT[6]	PTS
C13	S1_REQ#[4]	PIU	C14	VDD	PTS
C15	S1_REQ#[3]	PIU	C16	S1_CLKOUT[2]	PTS
C17	S1_REQ#[1]	PIU	C18	S1_AD[27]	PB
C19	S1_AD[28]	PB	C20	S1_AD[29]	PB
D1	S2_AD[18]	PB	D2	S2_FRAME#	PSTS
D3	S2_DEVSEL#	PSTS	D4	S2_PERR#	PSTS
D5	VDD	-	D6	S2_AD[13]	PB
D7	S1_M66EN	PI	D8	S2_AD[7]	PB
D9	S2_AD[5]	PB	D10	S2_AD[1]	PB
D11	VDD	-	D12	VSS	-
D13	S1_REQ#[5]	PIU	D14	S1_GNT#[3]	PO
D15	VDD	-	D16	S1_GNT#[1]	PO
D17	S1_AD[24]	PB	D18	VSS	-
D19	S1_AD[25]	PB	D20	S1_AD[26]	PB
E1	S2_AD[20]	PB	E2	VDD	-
E3	VSS	-	E4	S2_AD[19]	PB
E17	S1_AD[21]	PB	E18	S1_AD[22]	PB
E19	S1_AD[23]	PB	E20	S1_CBE[3]	PB
F1	S2_CBE[3]	PB	F2	S2_AD[23]	PB
F3	S2_AD[22]	PB	F4	S2_AD[21]	PB
F17	S1_AD[18]	PB	F18	VDD	-
F19	S1_AD[19]	PB	F20	S1_AD[20]	PB
G1	S2_AD[26]	PB	G2	VSS	-
G3	S2_AD[25]	PB	G4	S2_AD[24]	PB
G17	VSS	-	G18	S1_CBE[2]	PB
G19	S1_AD[16]	PB	G20	S1_AD[17]	PB
H1	S2_AD[30]	PB	H2	S2_AD[29]	PB
H3	S2_AD[28]	PB	H4	S2_AD[27]	PB
H17	VSS	-	H18	S1_TRDY#	PSTS
H19	S1_IRDY#	PSTS	H20	S1_FRAME#	PSTS
J1	S2_CLKOUT[0]	PTS	J2	VSS	-
J3	VDD	-	J4	S2_AD[31]	PB
J9	VSS	-	J10	VSS	-
J11	VSS	-	J12	VSS	-
J17	S1_PERR#	PSTS	J18	S1_LOCK#	PSTS
J19	S1_STOP#	PSTS	J20	S1_DEVSEL#	PSTS
K1	S2_REQ#[1]	PIU	K2	S2_GNT#[0]	PO

Pin #	Name	Type	Pin #	Name	Type
K3	S2_REQ#[0]	PIU	K4	VSS	-
K9	VSS	-	K10	VSS	-
K11	VSS	-	K12	VSS	-
K17	S1_CBE[1]	PB	K18	S1_PAR	PB
K19	VSS	-	K20	S1_SERR#	PI
L1	S2_GNT#[1]	PO	L2	S2_CLKOUT[1]	PTS
L3	S2_CLKOUT[2]	PTS	L4	S2_GNT#[2]	PO
L9	VSS	-	L10	VSS	-
L11	VSS	-	L12	VSS	-
L17	VDD	-	L18	S1_AD[13]	PB
L19	S1_AD[14]	PB	L20	S1_AD[15]	PB
M1	S2_REQ#[2]	PIU	M2	S2_REQ#[3]	PIU
M3	S2_GNT#[3]	PO	M4	S2_CLKOUT[3]	PTS
M9	VSS	-	M10	VSS	-
M11	VSS	-	M12	VSS	-
M17	S1_AD[10]	PB	M18	VSS	-
M19	S1_AD[11]	PB	M20	S1_AD[12]	PB
N1	VSS	-	N2	VDD	-
N3	S2_CLKOUT[4]	PTS	N4	S2_GNT#[4]	PO
N17	S1_AD[6]	PB	N18	S1_AD[7]	PB
N19	S1_AD[8]	PB	N20	S1_AD[9]	PB
P1	S2_REQ#[4]	PIU	P2	S2_REQ#[5]	PIU
P3	S2_CLKOUT[5]	PTS	P4	S2_GNT#[6]	PO
P17	S1_AD[5]	PB	P18	VSS	-
P19	VDD	-	P20	S1_CBE[0]	PB
R1	S2_GNT#[5]	PO	R2	VSS	-
R3	S2_REQ#[6]	PIU	R4	ENUM#	POD
R17	P_AD[0]	PB	R18	S1_AD[2]	PB
R19	S1_AD[3]	PB	R20	S1_AD[4]	PB
T1	S2_CLKOUT[6]	PTS	T2	HS_SW	PI
T3	S2_CLKOUT[7]	PTS	T4	S2_RESET#	PO
T17	P_AD[1]	PB	T18	VSS	-
T19	S1_AD[0]	PB	T20	S1_AD[1]	PB
U1	LOO	PO	U2	VSS	-
U3	TRST#	PIU	U4	AGND	-
U5	SCAN_EN	PID	U6	HS_EN	PI
U7	P_GNT#	PI	U8	P_AD[26]	PB
U9	VSS	-	U10	VDD	-
U11	P_AD[19]	PB	U12	P_CBE[2]	PB
U13	P_TRDY#	PB	U14	VSS	-
U15	P_PAR	PB	U16	P_CBE[1]	PB
U17	VSS	-	U18	P_AD[10]	PB
U19	P_AD[7]	PB	U20	P_AD[4]	PB
V1	VDD	-	V2	TCK	PIU
V3	TDO	PTS	V4	SCAN_TM#	PI
V5	S_CLKIN	PI	V6	P_CLK	PI
V7	VDD	-	V8	P_AD[27]	PB
V9	P_CBE[3]	PB	V10	P_AD[22]	PB
V11	P_AD[20]	PB	V12	P_AD[16]	PB
V13	P_IRDY#	PB	V14	P_LOCK#	PSTS
V15	VDD	-	V16	P_AD[15]	PB
V17	VSS	-	V18	P_M66EN#	PI
V19	P_CBE[0]	PB	V20	P_AD[3]	PB
W1	TMS	PIU	W2	TDI	PIU
W3	S1_EN	PIU	W4	S2_EN	PIU
W5	S2_M66EN	PI	W6	P_REQ#	PTS
W7	P_AD[30]	PB	W8	P_AD[28]	PB
W9	P_AD[24]	PB	W10	P_AD[23]	PB
W11	VSS	-	W12	P_AD[17]	PB
W13	P_FRAME#	PB	W14	P_STOP#	PSTS

Pin #	Name	Type	Pin #	Name	Type
W15	P_SERR#	POD	W16	P_AD[14]	PB
W17	P_AD[12]	PB	W18	P_AD[9]	PB
W19	P_AD[6]	PB	W20	VDD	-
Y1	AVCC	-	Y2	S_CFN#	PIU
Y3	PLL_TM	PI	Y4	BYPASS	-
Y5	P_RESET#	PI	Y6	VSS	-
Y7	P_AD[31]	PB	Y8	P_AD[29]	PB
Y9	P_AD[25]	PB	Y10	P_IDSEL	PI
Y11	P_AD[21]	PB	Y12	P_AD[18]	PB
Y13	VSS	-	Y14	P_DEVSEL#	PSTS
Y15	P_PERR#	PSTS	Y16	P_AD[13]	PB
Y17	P_AD[11]	PB	Y18	P_AD[8]	PB
Y19	P_AD[5]	PB	Y20	P_AD[2]	PB

4 PCI BUS OPERATION

This Chapter offers information about PCI transactions, transaction forwarding across PI7C7300D, and transaction termination. The PI7C7300D has three 128-byte buffers for buffering of upstream and downstream transactions. These hold addresses, data, commands, and byte enables and are used for both read and write transactions.

4.1 TYPES OF TRANSACTIONS

This section provides a summary of PCI transactions performed by PI7C7300D. Table 4-1 lists the command code and name of each PCI transaction. The Master and Target columns indicate support for each transaction when PI7C7300D initiates transactions as a master, on the primary (P) and secondary (S1, S2) buses, and when PI7C7300D responds to transactions as a target, on the primary (P) and secondary (S1, S2) buses.

Table 4-1 PCI TRANSACTIONS

Types of Transactions		Initiates as Master		Responds as Target	
		Primary	Secondary	Primary	Secondary
0000	Interrupt Acknowledge	N	N	N	N
0001	Special Cycle	Y	Y	N	N
0010	I/O Read	Y	Y	Y	Y
0011	I/O Write	Y	Y	Y	Y
0100	Reserved	N	N	N	N
0101	Reserved	N	N	N	N
0110	Memory Read	Y	Y	Y	Y
0111	Memory Write	Y	Y	Y	Y
1000	Reserved	N	N	N	N
1001	Reserved	N	N	N	N
1010	Configuration Read	N	Y	Y	N
1011	Configuration Write	Y (Type 1 only)	Y	Y	Y (Type 1 only)
1100	Memory Read Multiple	Y	Y	Y	Y
1101	Dual Address Cycle	Y	Y	Y	Y
1110	Memory Read Line	Y	Y	Y	Y
1111	Memory Write and Invalidate	Y	Y	Y	Y

As indicated in Table 4-1, the following PCI commands are not supported by PI7C7300D:

- PI7C7300D never initiates a PCI transaction with a reserved command code and, as a target, PI7C7300D ignores reserved command codes.
- PI7C7300D does not generate interrupt acknowledge transactions. PI7C7300D ignores interrupt acknowledge transactions as a target.
- PI7C7300D does not respond to special cycle transactions. PI7C7300D cannot guarantee delivery of a special cycle transaction to downstream buses because of the broadcast nature of the special cycle command and the inability to control the transaction as a target. To generate special cycle transactions on other PCI buses, either upstream or downstream, Type 1 configuration write must be used.
- PI7C7300D neither generates Type 0 configuration transactions on the primary PCI bus nor responds to Type 0 configuration transactions on the secondary PCI buses.

4.2 SINGLE ADDRESS PHASE

A 32-bit address uses a single address phase. This address is driven on P_AD[31:0], and the bus command is driven on P_CBE[3:0]. PI7C7300D supports the linear increment address mode only, which is indicated when the lowest two address bits are equal to zero. If either of the lowest two address bits is nonzero, PI7C7300D automatically disconnects the transaction after the first data transfer.

4.3 DUAL ADDRESS PHASE

A 64-bit address uses two address phases. The first address phase is denoted by the asserting edge of FRAME#. The second address phase always follows on the next clock cycle.

For a 32-bit interface, the first address phase contains dual address command code on the C/BE#[3:0] lines, and the low 32 address bits on the AD[31:0] lines. The second address phase consists of the specific memory transaction command code on the C/BE#[3:0] lines, and the high 32 address bits on the AD[31:0] lines. In this way, 64-bit addressing can be supported on 32-bit PCI buses.

The *PCI-to-PCI Bridge Architecture Specification* supports the use of dual address transactions in the prefetchable memory range only. See Section 5.3.2 for a discussion of prefetchable address space. The PI7C7300D supports dual address transactions in both the upstream and the downstream direction. The PI7C7300D supports a programmable 64-bit address range in prefetchable memory for downstream forwarding of dual address transactions. Dual address transactions falling outside the prefetchable address range are forwarded upstream, but not downstream. Prefetching and posting are performed in a manner consistent with the guidelines given in this specification for each type of memory transaction in prefetchable memory space.

4.4 DEVICE SELECT (DEVSEL#) GENERATION

PI7C7300D always performs positive address decoding (medium decode) when accepting transactions on either the primary or secondary buses. PI7C7300D never does subtractive decode.

4.5 DATA PHASE

The address phase of a PCI transaction is followed by one or more data phases. A data phase is completed when IRDY# and either TRDY# or STOP# are asserted. A transfer of data occurs only when both IRDY# and TRDY# are asserted during the same PCI clock cycle. The last data phase of a transaction is indicated when FRAME# is de-asserted and both TRDY# and IRDY# are asserted, or when IRDY# and STOP# are asserted. See Section 4.9 for further discussion of transaction termination.

Depending on the command type, PI7C7300D can support multiple data phase PCI transactions. For detailed descriptions of how PI7C7300D imposes disconnect boundaries, see Section 4.6.4 for write address boundaries and Section 4.7.3 read address boundaries.

4.6 WRITE TRANSACTIONS

Write transactions are treated as either posted write or delayed write transactions. Table 4-2 shows the method of forwarding used for each type of write operation.

Table 4-2 WRITE TRANSACTION FORWARDING

Type of Transaction	Type of Forwarding
Memory Write	Posted (except VGA memory)
Memory Write and Invalidate	Posted
Memory Write to VGA memory	Delayed
I/O Write	Delayed
Type 1 Configuration Write	Delayed

4.6.1 MEMORY WRITE TRANSACTIONS

Posted write forwarding is used for “Memory Write” and “Memory Write and Invalidate” transactions.

When PI7C7300D determines that a memory write transaction is to be forwarded across the bridge, PI7C7300D asserts DEVSEL# with medium timing and TRDY# in the next cycle, provided that enough buffer space is available in the posted memory write queue for the address and at least one DWORD of data. Under this condition, PI7C7300D accepts write data without obtaining access to the target bus. The PI7C7300D can accept one DWORD of write data every PCI clock cycle. That is, no target wait state is inserted. The write data is stored in an internal posted write buffers and is subsequently delivered to the target. The PI7C7300D continues to accept write data until one of the following events occurs:

- The initiator terminates the transaction by de-asserting FRAME# and IRDY#.
- An internal write address boundary is reached, such as a cache line boundary or an aligned 4KB boundary, depending on the transaction type.
- The posted write data buffer fills up.

When one of the last two events occurs, the PI7C7300D returns a target disconnect to the requesting initiator on this data phase to terminate the transaction.

Once the posted write data moves to the head of the posted data queue, PI7C7300D asserts its request on the target bus. This can occur while PI7C7300D is still receiving data on the initiator bus. When the grant for the target bus is received and the target bus is detected in the idle condition, PI7C7300D asserts FRAME# and drives the stored write address out on the target bus. On the following cycle, PI7C7300D drives the first DWORD of write data and continues to transfer write data until all write data corresponding to that transaction is delivered, or until a target termination is received. As long as write data exists in the queue, PI7C7300D can drive one DWORD of write data each PCI clock cycle; that is, no master wait states are inserted. If write data is flowing through PI7C7300D and the initiator stalls, PI7C7300D will signal the last data phase for the current transaction at the target bus if the queue empties. PI7C7300D will restart the follow-on transactions if the queue has new data.

PI7C7300D ends the transaction on the target bus when one of the following conditions is met:

- All posted write data has been delivered to the target.
- The target returns a target disconnect or target retry (PI7C7300D starts another transaction to deliver the rest of the write data).
- The target returns a target abort (PI7C7300D discards remaining write data).
- The master latency timer expires, and PI7C7300D no longer has the target bus grant (PI7C7300D starts another transaction to deliver remaining write data).

Section 4.9.3.2 provides detailed information about how PI7C7300D responds to target termination during posted write transactions.

4.6.2 MEMORY WRITE AND INVALIDATE TRANSACTIONS

Posted write forwarding is used for Memory Write and Invalidate transactions.

The PI7C7300D disconnects Memory Write and Invalidate commands at aligned cache line boundaries. The cache line size value in the cache line size register gives the number of DWORD in a cache line.

If the value in the cache line size register does not meet the memory write and invalidate conditions, the PI7C7300D returns a target disconnect to the initiator either on a cache line boundary or when the posted write buffer fills.

When the Memory Write and Invalidate transaction is disconnected before a cache line boundary is reached, typically because the posted write buffer fills, the transaction is converted to Memory Write transaction.

4.6.3 DELAYED WRITE TRANSACTIONS

Delayed write forwarding is used for I/O write transactions and Type 1 configuration write transactions.

A delayed write transaction guarantees that the actual target response is returned back to the initiator without holding the initiating bus in wait states. A delayed write transaction is limited to a single DWORD data transfer.

When a write transaction is first detected on the initiator bus, and PI7C7300D forwards it as a delayed transaction, PI7C7300D claims the access by asserting DEVSEL# and returns a target retry to the initiator. During the address phase, PI7C7300D samples the bus command, address, and address parity one cycle later. After IRDY# is asserted, PI7C7300D also samples the first data DWORD, byte enable bits, and data parity. This information is placed into the delayed transaction queue. The transaction is queued only if no other existing delayed transactions have the same address and command, and if the delayed transaction queue is not full. When the delayed write transaction moves to the head of the delayed transaction queue and all ordering constraints with posted data are satisfied. The PI7C7300D initiates the transaction on the target bus. PI7C7300D transfers the write data to the target. If PI7C7300D receives a target retry in response to the write transaction on the target bus, it continues to repeat the write transaction until the data transfer is completed, or until an error condition is encountered.

If PI7C7300D is unable to deliver write data after 2^{24} (default) or 2^{32} (maximum) attempts, PI7C7300D will report a system error. PI7C7300D also asserts P_SERR# if the primary SERR# enable bit is set in the command register. See Section 7.4 for information on the assertion of P_SERR#. When the initiator repeats the same write transaction (same command, address, byte enable bits, and data), and the completed delayed transaction is at the head of the queue, the PI7C7300D claims the access by asserting DEVSEL# and returns TRDY# to the initiator, to indicate that the write data

was transferred. If the initiator requests multiple DWORD, PI7C7300D also asserts STOP# in conjunction with TRDY# to signal a target disconnect. Note that only those

bytes of write data with valid byte enable bits are compared. If any of the byte enable bits are turned off (driven HIGH), the corresponding byte of write data is not compared.

If the initiator repeats the write transaction before the data has been transferred to the target, PI7C7300D returns a target retry to the initiator. PI7C7300D continues to return a target retry to the initiator until write data is delivered to the target, or until an error condition is encountered. When the write transaction is repeated, PI7C7300D does not make a new entry into the delayed transaction queue. Section 4.9.3.1 provides detailed information about how PI7C7300D responds to target termination during delayed write transactions.

PI7C7300D implements a discard timer that starts counting when the delayed write completion is at the head of the delayed transaction completion queue. The initial value of this timer can be set to the retry counter register offset 78h.

If the initiator does not repeat the delayed write transaction before the discard timer expires, PI7C7300D discards the delayed write completion from the delayed transaction completion queue. PI7C7300D also conditionally asserts P_SERR# (see Section 7.4).

4.6.4 WRITE TRANSACTION ADDRESS BOUNDARIES

PI7C7300D imposes internal address boundaries when accepting write data. The aligned address boundaries are used to prevent PI7C7300D from continuing a transaction over a device address boundary and to provide an upper limit on maximum latency. PI7C7300D returns a target disconnect to the initiator when it reaches the aligned address boundaries under conditions shown in Table 4-3.

Table 4-3 WRITE TRANSACTION DISCONNECT ADDRESS BOUNDARIES

Type of Transaction	Condition	Aligned Address Boundary
Delayed Write	All	Disconnects after one data transfer
Posted Memory Write	Memory write disconnect control bit = 0 ⁽¹⁾	4KB aligned address boundary
Posted Memory Write	Memory write disconnect control bit = 1 ⁽¹⁾	Disconnects at cache line boundary
Posted Memory Write and Invalidate	Cache line size ≠ 1, 2, 4, 8, 16	4KB aligned address boundary
Posted Memory Write and Invalidate	Cache line size = 1, 2, 4, 8, 16	Cache line boundary if posted memory write data FIFO does not have enough space for the cache line

Note 1. Memory write disconnect control bit is bit 1 of the chip control register at offset 40h in the configuration space.

4.6.5 BUFFERING MULTIPLE WRITE TRANSACTIONS

PI7C7300D continues to accept posted memory write transactions as long as space for at least one DWORD of data in the posted write data buffer remains. If the posted write data buffer fills before the initiator terminates the write transaction, PI7C7300D returns a target disconnect to the initiator.

Delayed write transactions are posted as long as at least one open entry in the delayed transaction queue exists. Therefore, several posted and delayed write transactions can exist in data buffers at the same time. See Chapter 6 for information about how multiple posted and delayed write transactions are ordered.

4.6.6 FAST BACK-TO-BACK WRITE TRANSACTIONS

PI7C7300D can recognize and post fast back-to-back write transactions. When PI7C7300D cannot accept the second transaction because of buffer space limitations, it returns a target retry to the initiator. The fast back-to-back enable bit must be set in the command register for upstream write transactions, and in the bridge control register for downstream write transactions.

4.7 READ TRANSACTIONS

Delayed read forwarding is used for all read transactions crossing PI7C7300D. Delayed read transactions are treated as either prefetchable or non-prefetchable. Table 4-4 shows the read behavior, prefetchable or non-prefetchable, for each type of read operation.

4.7.1 PREFETCHABLE READ TRANSACTIONS

A prefetchable read transaction is a read transaction where PI7C7300D performs speculative DWORD reads, transferring data from the target before it is requested from the initiator. This behavior allows a prefetchable read transaction to consist of multiple data transfers. However, byte enable bits cannot be forwarded for all data phases as is done for the single data phase of the non-prefetchable read transaction. For prefetchable read transactions, PI7C7300D forces all byte enable bits to be turned on for all data phases.

Prefetchable behavior is used for memory read line and memory read multiple transactions, as well as for memory read transactions that fall into prefetchable memory space. The amount of data that is pre-fetched depends on the type of transaction. The amount of pre-fetching may also be affected by the amount of free buffer space available in PI7C7300D, and by any read address boundaries encountered.

Pre-fetching should not be used for those read transactions that have side effects in the target device, that is, control and status registers, FIFOs, and so on. The target device's base address register or registers indicate if a memory address region is prefetchable.

4.7.2 NON-PREFETCHABLE READ TRANSACTIONS

A non-prefetchable read transaction is a read transaction where PI7C7300D requests one and only one DWORD from the target and disconnects the initiator after delivery of the first DWORD of read data. Unlike prefetchable read transactions, PI7C7300D forwards the read byte enable information for the data phase.

Non-prefetchable behavior is used for I/O and configuration read transactions, as well as for memory read transactions that fall into non-prefetchable memory space.

If extra read transactions could have side effects, for example, when accessing a FIFO, use non-prefetchable read transactions to those locations. Accordingly, if it is important to retain the value of the byte enable bits during the data phase, use non-prefetchable read transactions. If these locations are mapped in memory space, use the memory read command and map the target into non-prefetchable (memory-mapped I/O) memory space to use non-prefetching behavior.

4.7.3 READ PREFETCH ADDRESS BOUNDARIES

PI7C7300D imposes internal read address boundaries on read pre-fetched data. When a read transaction reaches one of these aligned address boundaries, the PI7C7300D stops pre-fetched data, unless the target signals a target disconnect before the read pre-fetched boundary is reached. When PI7C7300D finishes transferring this read data to the initiator, it returns a target disconnect with the last data transfer, unless the initiator completes the transaction before all pre-fetched read data is delivered. Any leftover pre-fetched data is discarded.

Prefetchable read transactions in flow-through mode pre-fetch to the nearest aligned 4KB address boundary, or until the initiator de-asserts FRAME#. Section 4.7.6 describes flow-through mode during read operations.

Table 4-5 shows the read pre-fetch address boundaries for read transactions during non-flow-through mode.

Table 4-4 READ PREFETCH ADDRESS BOUNDARIES

Type of Transaction	Address Space	Cache Line Size (CLS)	Prefetch Aligned Address Boundary
Configuration Read	-	*	One DWORD (no prefetch)
I/O Read	-	*	One DWORD (no prefetch)
Memory Read	Non-Prefetchable	*	One DWORD (no prefetch)
Memory Read	Prefetchable	CLS = 0 or 16	16-DWORD aligned address boundary
Memory Read	Prefetchable	CLS = 1, 2, 4, 8, 16	Cache line address boundary
Memory Read Line	-	CLS = 0 or 16	16-DWORD aligned address boundary
Memory Read Line	-	CLS = 1, 2, 4, 8, 16	Cache line boundary
Memory Read Multiple	-	CLS = 0 or 16	32-DWORD aligned address boundary
Memory Read Multiple	-	CLS = 1, 2, 4, 8, 16	2X of cache line boundary

- does not matter if it is prefetchable or non-prefetchable

* don't care

Table 4-5 READ TRANSACTION PREFETCHING

Type of Transaction	Read Behavior
I/O Read	Prefetching never allowed
Configuration Read	Prefetching never allowed
Memory Read	Downstream: Prefetching used if address is prefetchable space Upstream: Prefetching used or programmable
Memory Read Line	Prefetching always used
Memory Read Multiple	Prefetching always used

See Section 5.3 for detailed information about prefetchable and non-prefetchable address spaces.

4.7.4 DELAYED READ REQUESTS

PI7C7300D treats all read transactions as delayed read transactions, which means that the read request from the initiator is posted into a delayed transaction queue. Read data from the target is placed in the read data queue directed toward the initiator bus interface and is transferred to the initiator when the initiator repeats the read transaction.

When PI7C7300D accepts a delayed read request, it first samples the read address, read bus command, and address parity. When IRDY# is asserted, PI7C7300D then samples the byte enable bits for the first data phase. This information is entered into the delayed transaction queue. PI7C7300D terminates the transaction by signaling a target retry to the initiator. Upon reception of the target retry, the initiator is required to continue to repeat the same read transaction until at least one data transfer is completed, or until a target response (target abort or master abort) other than a target retry is received.

4.7.5 DELAYED READ COMPLETION WITH TARGET

When delayed read request reaches the head of the delayed transaction queue, PI7C7300D arbitrates for the target bus and initiates the read transaction only if all previously queued posted write transactions have been delivered. PI7C7300D uses the exact read address and read command captured from the initiator during the initial delayed read request to initiate the read transaction. If the read transaction is a non-prefetchable read, PI7C7300D drives the captured byte enable bits during the next cycle. If the transaction is a prefetchable read transaction, it drives all byte enable bits to zero for all data phases. If PI7C7300D receives a target retry in response to the read transaction on the target bus, it continues to repeat the read transaction until at least one data transfer is completed, or until an error condition is encountered. If the transaction is terminated via normal master termination or target disconnect after at least one data transfer has been completed, PI7C7300D does not initiate any further attempts to read more data.

If PI7C7300D is unable to obtain read data from the target after 2^{24} (default) or 2^{32} (maximum) attempts, PI7C7300D will report a system error. The number of attempts is programmable. PI7C7300D also asserts P_SERR# if the primary SERR# enable bit is set in the command register. See Section 7.4 for information on the assertion of P_SERR#.

Once PI7C7300D receives DEVSEL# and TRDY# from the target, it transfers the data read to the opposite direction read data queue, pointing toward the opposite inter-face, before terminating the

transaction. For example, read data in response to a downstream read transaction initiated on the primary bus is placed in the upstream read data queue. The PI7C7300D can accept one DWORD of read data each PCI clock cycle; that is, no master wait states are inserted. The number of DWORD transferred during a delayed read transaction depends on the conditions given in

Table 4-5 (assuming no disconnect is received from the target).

4.7.6 DELAYED READ COMPLETION ON INITIATOR BUS

When the transaction has been completed on the target bus, and the delayed read data is at the head of the read data queue, and all ordering constraints with posted write transactions have been satisfied, the PI7C7300D transfers the data to the initiator when the initiator repeats the transaction. For memory read transactions, PI7C7300D aliases the memory read, memory read line, and memory read multiple bus commands when matching the bus command of the transaction to the bus command in the delayed transaction queue. PI7C7300D returns a target disconnect along with the transfer of the last DWORD of read data to the initiator. If PI7C7300D initiator terminates the transaction before all read data has been transferred, the remaining read data left in data buffers is discarded.

When the master repeats the transaction and starts transferring prefetchable read data from data buffers while the read transaction on the target bus is still in progress and before a read boundary is reached on the target bus, the read transaction starts operating in flow-through mode. Because data is flowing through the data buffers from the target to the initiator, long read bursts can then be sustained. In this case, the read transaction is allowed to continue until the initiator terminates the transaction, or until an aligned 4KB address boundary is reached, or until the buffer fills, whichever comes first. When the buffer empties, PI7C7300D reflects the stalled condition to the initiator by disconnecting the initiator with data. The initiator may retry the transaction later if data are needed. If the initiator does not need any more data, the initiator will not continue the disconnected transaction. In this case, PI7C7300D will start the master timeout timer. The remaining read data will be discarded after the master timeout timer expires. To provide better latency, if there are any other pending data for other transactions in the RDB (Read Data Buffer), the remaining read data will be discarded even though the master timeout timer has not expired.

PI7C7300D implements a master timeout timer that starts counting when the delayed read completion is at the head of the delayed transaction queue, and the read data is at the head of the read data queue. The initial value of this timer is program-mable through configuration register. If the initiator does not repeat the read transaction and before the master timeout timer expires (2^{15} default), PI7C7300D discards the read transaction and read data from its queues. PI7C7300D also conditionally asserts P_SERR# (see Section 7.4).

PI7C7300D has the capability to post multiple delayed read requests, up to a maximum of four in each direction. If an initiator starts a read transaction that matches the address and read command of a read transaction that is already queued, the current read command is not posted as it is already contained in the delayed transaction queue.

See Section 6 for a discussion of how delayed read transactions are ordered when crossing PI7C7300D.

4.7.7 FAST BACK-TO-BACK READ TRANSACTION

PI7C7300D can recognize fast back-to-back read transactions.

4.8 CONFIGURATION TRANSACTIONS

Configuration transactions are used to initialize a PCI system. Every PCI device has a configuration space that is accessed by configuration commands. All registers are accessible in configuration space only.

In addition to accepting configuration transactions for initialization of its own configuration space, the PI7C7300D also forwards configuration transactions for device initialization in hierarchical PCI systems, as well as for special cycle generation.

To support hierarchical PCI bus systems, two types of configuration transactions are specified: Type 0 and Type 1.

Type 0 configuration transactions are issued when the intended target resides on the same PCI bus as the initiator. A Type 0 configuration transaction is identified by the configuration command and the lowest two bits of the address set to 00b.

Type 1 configuration transactions are issued when the intended target resides on another PCI bus, or when a special cycle is to be generated on another PCI bus. A Type 1 configuration command is identified by the configuration command and the lowest two address bits set to 01b.

The register number is found in both Type 0 and Type 1 formats and gives the DWORD address of the configuration register to be accessed. The function number is also included in both Type 0 and Type 1 formats and indicates which function of a multifunction device is to be accessed. For single-function devices, this value is not decoded. The addresses of Type 1 configuration transaction include a 5-bit field designating the device number that identifies the device on the target PCI bus that is to be accessed. In addition, the bus number in Type 1 transactions specifies the PCI bus to which the transaction is targeted.

4.8.1 TYPE 0 ACCESS TO PI7C7300D

The configuration space is accessed by a Type 0 configuration transaction on the primary interface. The configuration space cannot be accessed from the secondary bus. The PI7C7300D responds to a Type 0 configuration transaction by asserting P_DEVSEL# when the following conditions are met during the address phase:

- The bus command is a configuration read or configuration write transaction.
- Lowest two address bits P_AD[1:0] must be 00b.
- Signal P_IDSEL must be asserted.

Function code is either 0 for configuration space of S1, or 1 for configuration space of S2 as PI7C7300D is a multi-function device.

PI7C7300D limits all configuration access to a single DWORD data transfer and returns target-disconnect with the first data transfer if additional data phases are requested.

Because read transactions to configuration space do not have side effects, all bytes in the requested DWORD are returned, regardless of the value of the byte enable bits.

Type 0 configuration write and read transactions do not use data buffers; that is, these transactions are completed immediately, regardless of the state of the data buffers. The PI7C7300D ignores all Type 0 transactions initiated on the secondary interface.

4.8.2 TYPE 1 TO TYPE 0 CONVERSION

Type 1 configuration transactions are used specifically for device configuration in a hierarchical PCI bus system. A PCI-to-PCI bridge is the only type of device that should respond to a Type 1 configuration command. Type 1 configuration commands are used when the configuration access is intended for a PCI device that resides on a PCI bus other than the one where the Type 1 transaction is generated.

PI7C7300D performs a Type 1 to Type 0 translation when the Type 1 transaction is generated on the primary bus and is intended for a device attached directly to the secondary bus. PI7C7300D must convert the configuration command to a Type 0 format so that the secondary bus device can respond to it. Type 1 to Type 0 translations are performed only in the downstream direction; that is, PI7C7300D generates a Type 0 transaction only on the secondary bus, and never on the primary bus.

PI7C7300D responds to a Type 1 configuration transaction and translates it into a Type 0 transaction on the secondary bus when the following conditions are met during the address phase:

- The lowest two address bits on P_AD[1:0] are 01b.
- The bus number in address field P_AD[23:16] is equal to the value in the secondary bus number register in configuration space.
- The bus command on P_CBE[3:0] is a configuration read or configuration write transaction.

When PI7C7300D translates the Type 1 transaction to a Type 0 transaction on the secondary interface, it performs the following translations to the address:

- Sets the lowest two address bits on S1_AD[1:0] or S2_AD[1:0] to 00b.
- Decodes the device number and drives the bit pattern specified in Table 4-6 on S1_AD[31:16] or S2_AD[31:16] for the purpose of asserting the device's IDSEL signal.
- Sets S1_AD[15:11] or S2_AD[15:11] to 0.
- Leaves unchanged the function number and register number fields.

PI7C7300D asserts a unique address line based on the device number. These address lines may be used as secondary bus IDSEL signals. The mapping of the address lines depends on the device number in the Type 1 address bits P_AD[15:11]. Table 4-6 presents the mapping that PI7C7300D uses.

Table 4-6 DEVICE NUMBER TO IDSEL S1_AD OR S2_AD PIN MAPPING

Device Number	P_AD[15:11]	Secondary IDSEL S2_AD[31:16]	S1_AD[31:16]	or	S1_AD or S2_AD
---------------	-------------	------------------------------	--------------	----	----------------

0h	00000	0000 0000 0000 0001	16
1h	00001	0000 0000 0000 0010	17
2h	00010	0000 0000 0000 0100	18
3h	00011	0000 0000 0000 1000	19
4h	00100	0000 0000 0001 0000	20
5h	00101	0000 0000 0010 0000	21
6h	00110	0000 0000 0100 0000	22
7h	00111	0000 0000 1000 0000	23
8h	01000	0000 0001 0000 0000	24
9h	01001	0000 0010 0000 0000	25
Ah	01010	0000 0100 0000 0000	26
Bh	01011	0000 1000 0000 0000	27
Ch	01100	0001 0000 0000 0000	28
Dh	01101	0010 0000 0000 0000	29
Eh	01110	0100 0000 0000 0000	30
Fh	01111	1000 0000 0000 0000	31
10h – 1Eh	10000 – 11110	0000 0000 0000 0000	-
1Fh	11111	Generate special cycle (P_AD[7:2] = 00h) 0000 0000 0000 0000 (P_AD[7:2] = 00h)	-

PI7C7300D can assert up to 16 unique address lines to be used as IDSEL signals for up to 16 devices on the secondary bus, for device numbers ranging from 0 through 15. Because of electrical loading constraints of the PCI bus, more than 16 IDSEL signals should not be necessary. However, if device numbers greater than 15 are desired, some external method of generating IDSEL lines must be used, and no upper address bits are then asserted. The configuration transaction is still translated and passed from the primary bus to the secondary bus. If no IDSEL pin is asserted to a secondary device, the transaction ends in a master abort.

PI7C7300D forwards Type 1 to Type 0 configuration read or write transactions as delayed transactions. Type 1 to Type 0 configuration read or write transactions are limited to a single 32-bit data transfer.

4.8.3 TYPE 1 TO TYPE 1 FORWARDING

Type 1 to Type 1 transaction forwarding provides a hierarchical configuration mechanism when two or more levels of PCI-to-PCI bridges are used.

When PI7C7300D detects a Type 1 configuration transaction intended for a PCI bus downstream from the secondary bus, PI7C7300D forwards the transaction unchanged to the secondary bus. Ultimately, this transaction is translated to a Type 0 configuration command or to a special cycle transaction by a downstream PCI-to-PCI bridge. Downstream Type 1 to Type 1 forwarding occurs when the following conditions are met during the address phase:

- The lowest two address bits are equal to 01b.
- The bus number falls in the range defined by the lower limit (exclusive) in the secondary bus number register and the upper limit (inclusive) in the subordinate bus number register.
- The bus command is a configuration read or write transaction.

PI7C7300D also supports Type 1 to Type 1 forwarding of configuration write transactions upstream to support upstream special cycle generation. A Type 1 configuration command is forwarded upstream when the following conditions are met:

- The lowest two address bits are equal to 01b.
- The bus number falls outside the range defined by the lower limit (inclusive) in the secondary bus number register and the upper limit (inclusive) in the subordinate bus number register.
- The device number in address bits AD[15:11] is equal to 11111b.
- The function number in address bits AD[10:8] is equal to 111b.
- The bus command is a configuration write transaction.

The PI7C7300D forwards Type 1 to Type 1 configuration write transactions as delayed transactions. Type 1 to Type 1 configuration write transactions are limited to a single data transfer.

4.8.4 SPECIAL CYCLES

The Type 1 configuration mechanism is used to generate special cycle transactions in hierarchical PCI systems. Special cycle transactions are ignored by acting as a target and are not forwarded across the bridge. Special cycle transactions can be generated from Type 1 configuration write transactions in either the upstream or the down-stream direction.

PI7C7300D initiates a special cycle on the target bus when a Type 1 configuration write transaction is being detected on the initiating bus and the following conditions are met during the address phase:

- The lowest two address bits on AD[1:0] are equal to 01b.
- The device number in address bits AD[15:11] is equal to 11111b.
- The function number in address bits AD[10:8] is equal to 111b.
- The register number in address bits AD[7:2] is equal to 000000b.
- The bus number is equal to the value in the secondary bus number register in configuration space for downstream forwarding or equal to the value in the primary bus number register in configuration space for upstream forwarding.
- The bus command on CBE# is a configuration write command.

When PI7C7300D initiates the transaction on the target interface, the bus command is changed from configuration write to special cycle. The address and data are forwarded unchanged. Devices that use special cycles ignore the address and decode only the bus command. The data phase contains the special cycle message. The transaction is forwarded as a delayed transaction, but in this case the target response is not forwarded back (because special cycles result in a master abort). Once the transaction is completed on the target bus, through detection of the master abort condition, PI7C7300D responds with TRDY# to the next attempt of the configuration transaction from the initiator. If more than one data transfer is requested, PI7C7300D responds with a target disconnect operation during the first data phase.

4.9 TRANSACTION TERMINATION

This section describes how PI7C7300D returns transaction termination conditions back to the initiator. The initiator can terminate transactions with one of the following types of termination:

- **Normal termination**
Normal termination occurs when the initiator de-asserts FRAME# at the beginning of the last data phase, and de-asserts IRDY# at the end of the last data phase in conjunction with either TRDY# or STOP# assertion from the target.
- **Master abort**
A master abort occurs when no target response is detected. When the initiator does not detect a DEVSEL# from the target within five clock cycles after asserting FRAME#, the initiator terminates the transaction with a master abort. If FRAME# is still asserted, the initiator de-asserts FRAME# on the next cycle, and then de-asserts IRDY# on the following cycle. IRDY# must be asserted in the same cycle in which FRAME# de-asserts. If FRAME# is already de-asserted, IRDY# can be de-asserted on the next clock cycle following detection of the master abort condition.

The target can terminate transactions with one of the following types of termination:

- **Normal termination**
TRDY# and DEVSEL# asserted in conjunction with FRAME# de-asserted and IRDY# asserted.
- **Target retry**
STOP# and DEVSEL# asserted with TRDY# de-asserted during the first data phase. No data transfers occur during the transaction. This transaction must be repeated.
- **Target disconnect with data transfer**
STOP#, DEVSEL# and TRDY# asserted. It signals that this is the last data transfer of the transaction.
- **Target disconnect without data transfer**
STOP# and DEVSEL# asserted with TRDY# de-asserted after previous data transfers have been made. Indicates that no more data transfers will be made during this transaction.
- **Target abort**
STOP# asserted with DEVSEL# and TRDY# de-asserted. Indicates that target will never be able to complete this transaction. DEVSEL# must be asserted for at least one cycle during the transaction before the target abort is signaled.

4.9.1 MASTER TERMINATION INITIATED BY PI7C7300D

PI7C7300D, as an initiator, uses normal termination if DEVSEL# is returned by target within five clock cycles of PI7C7300D's assertion of FRAME# on the target bus. As an initiator, PI7C7300D terminates a transaction when the following conditions are met:

- During a delayed write transaction, a single DWORD is delivered.
- During a non-prefetchable read transaction, a single DWORD is transferred from the target.
- During a prefetchable read transaction, a pre-fetch boundary is reached.

- For a posted write transaction, all write data for the transaction is transferred from data buffers to the target.
- For burst transfer, with the exception of “Memory Write and Invalidate” transactions, the master latency timer expires and the PI7C7300D’s bus grant is de-asserted.
- The target terminates the transaction with a retry, disconnect, or target abort.

If PI7C7300D is delivering posted write data when it terminates the transaction because the master latency timer expires, it initiates another transaction to deliver the remaining write data. The address of the transaction is updated to reflect the address of the current DWORD to be delivered.

If PI7C7300D is pre-fetching read data when it terminates the transaction because the master latency timer expires, it does not repeat the transaction to obtain more data.

4.9.2 MASTER ABORT RECEIVED BY PI7C7300D

If the initiator initiates a transaction on the target bus and does not detect DEVSEL# returned by the target within five clock cycles of the assertion of FRAME#, PI7C7300D terminates the transaction with a master abort. This sets the received-master-abort bit in the status register corresponding to the target bus.

For delayed read and write transactions, PI7C7300D is able to reflect the master abort condition back to the initiator. When PI7C7300D detects a master abort in response to a delayed transaction, and when the initiator repeats the transaction, PI7C7300D does not respond to the transaction with DEVSEL# which induces the master abort condition back to the initiator. The transaction is then removed from the delayed transaction queue. When a master abort is received in response to a posted write transaction, PI7C7300D discards the posted write data and makes no more attempts to deliver the data. PI7C7300D sets the received-master-abort bit in the status register when the master abort is received on the primary bus, or it sets the received master abort bit in the secondary status register when the master abort is received on the secondary interface. When master abort is detected in posted write transaction with both master-abort-mode bit (bit 5 of bridge control register) and the SERR# enable bit (bit 8 of command register for secondary bus S1 or S2) are set, PI7C7300D asserts P_SERR# if the master-abort-on-posted-write is not set. The master-abort-on-posted-write bit is bit 4 of the P_SERR# event disable register (offset 64h).

Note: When PI7C7300D performs a Type 1 to special cycle conversion, a master abort is the expected termination for the special cycle on the target bus. In this case, the master abort received bit is not set, and the Type 1 configuration transaction is disconnected after the first data phase.

4.9.3 TARGET TERMINATION RECEIVED BY PI7C7300D

When PI7C7300D initiates a transaction on the target bus and the target responds with DEVSEL#, the target can end the transaction with one of the following types of termination:

- Normal termination (upon de-assertion of FRAME#)
- Target retry
- Target disconnect
- Target abort

PI7C7300D handles these terminations in different ways, depending on the type of transaction being performed.

4.9.3.1 DELAYED WRITE TARGET TERMINATION RESPONSE

When PI7C7300D initiates a delayed write transaction, the type of target termination received from the target can be passed back to the initiator. Table 4-7 shows the response to each type of target termination that occurs during a delayed write transaction.

PI7C7300D repeats a delayed write transaction until one of the following conditions is met:

- PI7C7300D completes at least one data transfer.
- PI7C7300D receives a master abort.
- PI7C7300D receives a target abort.

PI7C7300D makes 2^{24} (default) or 2^{32} (maximum) write attempts resulting in a response of target retry.

Table 4-7 DELAYED WRITE TARGET TERMINATION RESPONSE

Target Termination	Response
Normal	Returning disconnect to initiator with first data transfer only if multiple data phases requested.
Target Retry	Returning target retry to initiator. Continue write attempts to target
Target Disconnect	Returning disconnect to initiator with first data transfer only if multiple data phases requested.
Target Abort	Returning target abort to initiator. Set received target abort bit in target interface status register. Set signaled target abort bit in initiator interface status register.

After the PI7C7300D makes 2^{24} (default) attempts of the same delayed write transaction on the target bus, PI7C7300D asserts P_SERR# if the SERR# enable bit (bit 8 of command register for secondary bus S1 or S2) is set and the delayed-write-non-delivery bit is not set. The delayed-write-non-delivery bit is bit 5 of P_SERR# event disable register (offset 64h). PI7C7300D will report system error. See Section 7.4 for a description of system error conditions.

4.9.3.2 POSTED WRITE TARGET TERMINATION RESPONSE

When PI7C7300D initiates a posted write transaction, the target termination cannot be passed back to the initiator. Table 4-8 shows the response to each type of target termination that occurs during a posted write transaction.

Table 4-8 RESPONSE TO POSTED WRITE TARGET TERMINATION

Target Termination	Response
Normal	No additional action.
Target Retry	Repeating write transaction to target.
Target Disconnect	Initiate write transaction for delivering remaining posted write data.

Target Termination	Response
Target Abort	Set received-target-abort bit in the target interface status register. Assert P_SERR# if enabled, and set the signaled-system-error bit in primary status register.

Note that when a target retry or target disconnect is returned and posted write data associated with that transaction remains in the write buffers, PI7C7300D initiates another write transaction to attempt to deliver the rest of the write data. If there is a target retry, the exact same address will be driven as for the initial write transaction attempt. If a target disconnect is received, the address that is driven on a subsequent write transaction attempt will be updated to reflect the address of the current DWORD. If the initial write transaction is Memory-Write-and-Invalidate transaction, and a partial delivery of write data to the target is performed before a target disconnect is received, PI7C7300D will use the memory write command to deliver the rest of the write data. It is because an incomplete cache line will be transferred in the subsequent write transaction attempt.

After the PI7C7300D makes 2²⁴ (default) write transaction attempts and fails to deliver all posted write data associated with that transaction, PI7C7300D asserts P_SERR# if the primary SERR# enable bit is set (bit 8 of command register for secondary bus S1 or S2) and posted-write-non-delivery bit is not set. The posted-write-non-delivery bit is the bit 2 of P_SERR# event disable register (offset 64h). PI7C7300D will report system error. See Section 7.4 for a discussion of system error conditions.

4.9.3.3 DELAYED READ TARGET TERMINATION RESPONSE

When PI7C7300D initiates a delayed read transaction, the abnormal target responses can be passed back to the initiator. Other target responses depend on how much data the initiator requests. Table 4-9 shows the response to each type of target termination that occurs during a delayed read transaction.

PI7C7300D repeats a delayed read transaction until one of the following conditions is met:

- PI7C7300D completes at least one data transfer.
- PI7C7300D receives a master abort.
- PI7C7300D receives a target abort.
- PI7C7300D makes 2²⁴ (default) read attempts resulting in a response of target retry.

Table 4-9 RESPONSE TO DELAYED READ TARGET TERMINATION

Target Termination	Response
Normal	If prefetchable, target disconnect only if initiator requests more data than read from target. If non-prefetchable, target disconnect on first data phase.
Target Retry	Re-initiate read transaction to target
Target Disconnect	If initiator requests more data than read from target, return target disconnect to initiator.
Target Abort	Return target abort to initiator. Set received target abort bit in the target interface status register. Set signaled target abort bit in the initiator interface status register.

After PI7C7300D makes 2²⁴(default) attempts of the same delayed read transaction on the target bus, PI7C7300D asserts P_SERR# if the primary SERR# enable bit is set (bit 8 of command register for secondary bus S1 or S2) and the delayed-write-non-delivery bit is not set. The delayed-write-non-delivery bit is bit 5 of P_SERR# event disable register

(offset 64h). PI7C7300D will report system error. See Section 7.4 for a description of system error conditions.

4.9.4 TARGET TERMINATION INITIATED BY PI7C7300D

PI7C7300D can return a target retry, target disconnect, or target abort to an initiator for reasons other than detection of that condition at the target interface.

4.9.4.1 TARGET RETRY

PI7C7300D returns a target retry to the initiator when it cannot accept write data or return read data as a result of internal conditions. PI7C7300D returns a target retry to an initiator when any of the following conditions is met:

For delayed write transactions:

- The transaction is being entered into the delayed transaction queue.
- Transaction has already been entered into delayed transaction queue, but target response has not yet been received.
- Target response has been received but has not progressed to the head of the return queue.
- The delayed transaction queue is full, and the transaction cannot be queued.
- A transaction with the same address and command has been queued.
- A locked sequence is being propagated across PI7C7300D, and the write transaction is not a locked transaction.
- The target bus is locked and the write transaction is a locked transaction.
- Use more than 16 clocks to accept this transaction.

For delayed read transactions:

- The transaction is being entered into the delayed transaction queue.
- The read request has already been queued, but read data is not yet available.
- Data has been read from target, but it is not yet at head of the read data queue or a posted write transaction precedes it.
- The delayed transaction queue is full, and the transaction cannot be queued.
- A delayed read request with the same address and bus command has already been queued.
- A locked sequence is being propagated across PI7C7300D, and the read transaction is not a locked transaction.
- PI7C7300D is currently discarding previously pre-fetched read data.
- The target bus is locked and the write transaction is a locked transaction.
- Use more than 16 clocks to accept this transaction.

For posted write transactions:

- The posted write data buffer does not have enough space for address and at least one DWORD of write data.
- A locked sequence is being propagated across PI7C7300D, and the write transaction is not a locked transaction.

When a target retry is returned to the initiator of a delayed transaction, the initiator must repeat the transaction with the same address and bus command as well as the data if it is a write transaction, within the time frame specified by the master timeout value. Otherwise, the transaction is discarded from the buffers.

4.9.4.2 TARGET DISCONNECT

PI7C7300D returns a target disconnect to an initiator when one of the following conditions is met:

- PI7C7300D hits an internal address boundary.
- PI7C7300D cannot accept any more write data.
- PI7C7300D has no more read data to deliver.

See Section 4.6.4 for a description of write address boundaries, and Section 4.7.3 for a description of read address boundaries.

4.9.4.3 TARGET ABORT

PI7C7300D returns a target abort to an initiator when one of the following conditions is met:

- PI7C7300D is returning a target abort from the intended target.

When PI7C7300D returns a target abort to the initiator, it sets the signaled target abort bit in the status register corresponding to the initiator interface.

4.10 CONCURRENT MODE OPERATION

The Bridge can be configured to run in concurrent operation. Concurrent operation is defined as cycles going from one device on one secondary bus to another device on the same or other secondary bus. This off-loads traffic from the primary bus, allowing other traffic to run on the primary bus concurrently.

The Bridge is already configured to handle concurrent operation. However, the devices themselves need to be configured to do so. Meaning, device drivers for the specific device used will have to be configured to perform the operation. Please see section 5.1 for more information on addressing.

5 ADDRESS DECODING

PI7C7300D uses three address ranges that control I/O and memory transaction forwarding. These address ranges are defined by base and limit address registers in the configuration space. This chapter describes these address ranges, as well as ISA-mode and VGA-addressing support.

5.1 ADDRESS RANGES

PI7C7300D uses the following address ranges that determine which I/O and memory transactions are forwarded from the primary PCI bus to the secondary PCI bus, and from the secondary bus to the primary bus:

- Two 32-bit I/O address ranges
- Two 32-bit memory-mapped I/O (non-prefetchable memory) ranges
- Two 32-bit prefetchable memory address ranges

Transactions falling within these ranges are forwarded downstream from the primary PCI bus to the two secondary PCI buses. Transactions falling outside these ranges are forwarded upstream from the two secondary PCI buses to the primary PCI bus.

No address translation is required in PI7C7300D. The addresses that are not marked for downstream are always forwarded upstream. However, if an address of a transaction initiated from S1 bus is located in the marked address range for downstream in S2 bus and not in the marked address range for downstream in S1 bus, the transaction will be forwarded to S2 bus instead of primary bus. By the same token, if an address of a transaction initiated from S2 bus is located in the marked address range for downstream in S1 bus and not in the marked address range for downstream in S2 bus, the transaction will be forwarded to S1 bus instead of primary bus.

5.2 I/O ADDRESS DECODING

PI7C7300D uses the following mechanisms that are defined in the configuration space to specify the I/O address space for downstream and upstream forwarding:

- I/O base and limit address registers
- The ISA enable bit
- The VGA mode bit
- The VGA snoop bit

This section provides information on the I/O address registers and ISA mode. Section 5.4 provides information on the VGA modes.

To enable downstream forwarding of I/O transactions, the I/O enable bit must be set in the command register in configuration space. All I/O transactions initiated on the primary bus will be ignored if the I/O enable bit is not set. To enable upstream forwarding of I/O transactions, the master enable bit must be set in the command register. If the master-enable bit is not set, PI7C7300D ignores all I/O and memory transactions initiated on the secondary bus.

The master-enable bit also allows upstream forwarding of memory transactions if it is set.

CAUTION

If any configuration state affecting I/O transaction forwarding is changed by a configuration write operation on the primary bus at the same time that I/O

transactions are ongoing on the secondary bus, PI7C7300D response to the secondary bus I/O transactions is not predictable. Configure the I/O base and limit address registers, ISA enable bit, VGA mode bit, and VGA snoop bit before setting I/O enable and master enable bits, and change them subsequently only when the primary and secondary PCI buses are idle.

5.2.1 I/O BASE AND LIMIT ADDRESS REGISTER

PI7C7300D implements one set of I/O base and limit address registers in configuration space that define an I/O address range per port downstream forwarding. PI7C7300D supports 32-bit I/O addressing, which allows I/O addresses downstream of PI7C7300D to be mapped anywhere in a 4GB I/O address space.

I/O transactions with addresses that fall inside the range defined by the I/O base and limit registers are forwarded downstream from the primary PCI bus to the secondary PCI bus. I/O transactions with addresses that fall outside this range are forwarded upstream from the secondary PCI bus to the primary PCI bus.

The I/O range can be turned off by setting the I/O base address to a value greater than that of the I/O limit address. When the I/O range is turned off, all I/O transactions are forwarded upstream, and no I/O transactions are forwarded downstream. The I/O range has a minimum granularity of 4KB and is aligned on a 4KB boundary. The maximum I/O range is 4GB in size. The I/O base register consists of an 8-bit field at configuration address 1Ch, and a 16-bit field at address 30h. The top 4 bits of the 8-bit field define bits [15:12] of the I/O base address.

The bottom 4 bits read only as 1h to indicate that PI7C7300D supports 32-bit I/O addressing. Bits [11:0] of the base address are assumed to be 0, which naturally aligns the base address to a 4KB boundary. The 16 bits contained in the I/O base upper 16 bits register at configuration offset 30h define AD[31:16] of the I/O base address. All 16 bits are read/write. After primary bus reset or chip reset, the value of the I/O base address is initialized to 0000 0000h.

The I/O limit register consists of an 8-bit field at configuration offset 1Dh and a 16-bit field at offset 32h. The top 4 bits of the 8-bit field define bits [15:12] of the I/O limit address. The bottom 4 bits read only as 1h to indicate that 32-bit I/O addressing is supported. Bits [11:0] of the limit address are assumed to be FFFh, which naturally aligns the limit address to the top of a 4KB I/O address block. The 16 bits contained in the I/O limit upper 16 bits register at configuration offset 32h define AD[31:16] of the I/O limit address. All 16 bits are read/write. After primary bus reset or chip reset, the value of the I/O limit address is reset to 0000 0FFFh.

Note: The initial states of the I/O base and I/O limit address registers define an I/O range of 0000 0000h to 0000 0FFFh, which is the bottom 4KB of I/O space. Write these registers with their appropriate values before setting either the I/O enable bit or the master enable bit in the command register in configuration space.

5.2.2 ISA MODE

PI7C7300D supports ISA mode by providing an ISA enable bit in the bridge control register in configuration space. ISA mode modifies the response of PI7C7300D inside the I/O address range in order to support mapping of I/O space in the presence of an ISA bus in the system. This bit only affects the response of PI7C7300D when the transaction falls inside the address range defined by the I/O base and limit address registers, and only when this address also falls inside the first 64KB of I/O space (address bits [31:16] are 0000h). When the ISA enable bit is set, PI7C7300D does not forward downstream any I/O transactions addressing the top 768 bytes of each aligned 1KB block. Only those transactions addressing the bottom 256 bytes of an aligned 1KB block inside the base and limit I/O address range are forwarded downstream. Transactions above the 64KB I/O address boundary are forwarded as defined by the address range defined by the I/O base and limit registers.

Accordingly, if the ISA enable bit is set, PI7C7300D forwards upstream those I/O transactions addressing the top 768 bytes of each aligned 1KB block within the first 64KB of I/O space. The master enable bit in the command configuration register must also be set to enable upstream forwarding. All other I/O transactions initiated on the secondary bus are forwarded upstream only if they fall outside the I/O address range.

When the ISA enable bit is set, devices downstream of PI7C7300D can have I/O space mapped into the first 256 bytes of each 1KB chunk below the 64KB boundary, or anywhere in I/O space above the 64KB boundary.

5.3 MEMORY ADDRESS DECODING

PI7C7300D has three mechanisms for defining memory address ranges for forwarding of memory transactions:

- Memory-mapped I/O base and limit address registers
- Prefetchable memory base and limit address registers
- VGA mode

This section describes the first two mechanisms. Section 5.4.1 describes VGA mode. To enable downstream forwarding of memory transactions, the memory enable bit must be set in the command register in configuration space. To enable upstream forwarding of memory transactions, the master-enable bit must be set in the command register. The master-enable bit also allows upstream forwarding of I/O transactions if it is set.

CAUTION

If any configuration state affecting memory transaction forwarding is changed by a configuration write operation on the primary bus at the same time that memory transactions are ongoing on the secondary bus, response to the secondary bus memory transactions is not predictable. Configure the memory-mapped I/O base and limit address registers, prefetchable memory base and limit address registers, and VGA mode bit before setting the memory enable and master enable bits, and change them subsequently only when the primary and secondary PCI buses are idle.

5.3.1 MEMORY-MAPPED I/O BASE AND LIMIT ADDRESS REGISTERS

Memory-mapped I/O is also referred to as non-prefetchable memory. Memory addresses that cannot automatically be pre-fetched but that can be conditionally prefetched based on command type should be mapped into this space. Read transactions to non-prefetchable space may exhibit side effects; this space may have non-memory-like behavior. PI7C7300D prefetches in this space only if the memory read line or memory read multiple commands are used; transactions using the memory read command are limited to a single data transfer.

The memory-mapped I/O base address and memory-mapped I/O limit address registers define an address range that PI7C7300D uses to determine when to forward memory commands. PI7C7300D forwards a memory transaction from the primary to the secondary interface if the transaction address falls within the memory-mapped I/O address range. PI7C7300D ignores memory transactions initiated on the secondary interface that fall into this address range. Any transactions that fall outside this address range are ignored on the primary interface and are forwarded upstream from the secondary interface (provided that they do not fall into the prefetchable memory range or are not forwarded downstream by the VGA mechanism).

The memory-mapped I/O range supports 32-bit addressing only. The PCI-to-PCI Bridge Architecture Specification does not provide for 64-bit addressing in the memory-mapped I/O space. The memory-mapped I/O address range has a granularity and alignment of 1MB. The maximum memory-mapped I/O address range is 4GB.

The memory-mapped I/O address range is defined by a 16-bit memory-mapped I/O base address register at configuration offset 20h and by a 16-bit memory-mapped I/O limit address register at offset 22h. The top 12 bits of each of these registers correspond to bits [31:20] of the memory address. The low 4 bits are hardwired to 0. The lowest 20 bits of the memory-mapped I/O base address are assumed to be 0 0000h, which results in a natural alignment to a 1MB boundary. The lowest 20 bits of the memory-mapped I/O limit address are assumed to be FFFFh, which results in an alignment to the top of a 1MB block.

Note: The initial state of the memory-mapped I/O base address register is 0000 0000h. The initial state of the memory-mapped I/O limit address register is 000F

FFFFh. Note that the initial states of these registers define a memory-mapped I/O range at the bottom 1MB block of memory. Write these registers with their appropriate values before setting either the memory enable bit or the master enable bit in the command register in configuration space.

To turn off the memory-mapped I/O address range, write the memory-mapped I/O base address register with a value greater than that of the memory-mapped I/O limit address register.

5.3.2 PREFETCHABLE MEMORY BASE AND LIMIT ADDRESS REGISTERS

Locations accessed in the prefetchable memory address range must have true memory-like behavior and must not exhibit side effects when read. This means that extra reads to a prefetchable memory location must have no side effects. PI7C7300D pre-fetches for all types of memory read commands in this address space.

The prefetchable memory base address and prefetchable memory limit address registers define an address range that PI7C7300D uses to determine when to forward memory commands. PI7C7300D forwards a memory transaction from the primary to the secondary interface if the transaction address falls within the prefetchable memory address range. PI7C7300D ignores memory transactions initiated on the secondary interface that fall into this address range. PI7C7300D does not respond to any transactions that fall outside this address range on the primary interface and forwards those transactions upstream from the secondary interface (provided that they do not fall into the memory-mapped I/O range or are not forwarded by the VGA mechanism).

The prefetchable memory range supports 64-bit addressing and provides additional registers to define the upper 32 bits of the memory address range, the prefetchable memory base address upper 32 bits register, and the prefetchable memory limit address upper 32 bits register. For address comparison, a single address cycle (32-bit address) prefetchable memory transaction is treated like a 64-bit address transaction where the upper 32 bits of the address are equal to 0. This upper 32-bit value of 0 is compared to the prefetchable memory base address upper 32 bits register and the prefetchable memory limit address upper 32 bits register. The prefetchable memory base address upper 32 bits register must be 0 to pass any single address cycle transactions downstream.

Prefetchable memory address range has a granularity and alignment of 1MB. Maximum memory address range is 4GB when 32-bit addressing is being used. Prefetchable memory address range is defined by a 16-bit prefetchable memory base address register at configuration offset 24h and by a 16-bit prefetchable memory limit address register at offset 26h. The top 12 bits of each of these registers correspond to bits [31:20] of the memory address. The lowest 4 bits are hardwired to 1h. The lowest 20 bits of the prefetchable memory base address are assumed to be 0 0000h, which results in a natural alignment to a 1MB boundary. The lowest 20 bits of the prefetchable memory limit address are assumed to be FFFFh, which results in an alignment to the top of a 1MB block.

Note: The initial state of the prefetchable memory base address register is 0000 0000h. The initial state of the prefetchable memory limit address register is 000F FFFFh. Note that the initial states of these registers define a prefetchable memory range at the bottom 1MB block of memory. Write these registers with their appropriate values before setting either the memory enable bit or the master enable bit in the command register in configuration space.

To turn off the prefetchable memory address range, write the prefetchable memory base address register with a value greater than that of the prefetchable memory limit address register. The entire base value must be greater than the entire limit value, meaning that the upper 32 bits must be considered. Therefore, to disable the address range, the upper

32 bits registers can both be set to the same value, while the lower base register is set greater than the lower limit register. Otherwise, the upper 32-bit base must be greater than the upper 32-bit limit.

5.4 VGA SUPPORT

PI7C7300D provides two modes for VGA support:

- VGA mode, supporting VGA-compatible addressing
- VGA snoop mode, supporting VGA palette forwarding

5.4.1 VGA MODE

When a VGA-compatible device exists downstream from PI7C7300D, set the VGA mode bit in the bridge control register in configuration space to enable VGA mode. When PI7C7300D is operating in VGA mode, it forwards downstream those transactions addressing the VGA frame buffer memory and VGA I/O registers, regardless of the values of the base and limit address registers. PI7C7300D ignores transactions initiated on the secondary interface addressing these locations.

The VGA frame buffer consists of the following memory address range:

000A 0000h–000B FFFFh

Read transactions to frame buffer memory are treated as non-prefetchable. PI7C7300D requests only a single data transfer from the target, and read byte enable bits are forwarded to the target bus.

The VGA I/O addresses are in the range of 3B0h–3BBh and 3C0h–3DFh I/O. These I/O addresses are aliases every 1KB throughout the first 64KB of I/O space. This means that address bits <15:10> are not decoded and can be any value, while address bits [31:16] must be all 0s. VGA BIOS addresses starting at C0000h are not decoded in VGA mode.

5.4.2 VGA SNOOP MODE

PI7C7300D provides VGA snoop mode, allowing for VGA palette write transactions to be forwarded downstream. This mode is used when a graphics device downstream from PI7C7300D needs to snoop or respond to VGA palette write transactions. To enable the mode, set the VGA snoop bit in the command register in configuration space. Note that PI7C7300D claims VGA palette write transactions by asserting DEVSEL# in VGA snoop mode.

When VGA snoop bit is set, PI7C7300D forwards downstream transactions within the 3C6h, 3C8h and 3C9h I/O addresses space. Note that these addresses are also forwarded as part of the VGA compatibility mode previously described. Again, address bits <15:10> are not decoded, while address bits <31:16> must be equal to 0, which means that these addresses are aliases every 1KB throughout the first 64KB of I/O space.

Note: If both the VGA mode bit and the VGA snoop bit are set, PI7C7300D behaves in the same way as if only the VGA mode bit were set.

6 TRANSACTION ORDERING

To maintain data coherency and consistency, PI7C7300D complies with the ordering rules set forth in the *PCI Local Bus Specification, Revision 2.2*, for transactions crossing the bridge. This chapter describes the ordering rules that control transaction forwarding across PI7C7300D.

6.1 TRANSACTIONS GOVERNED BY ORDERING RULES

Ordering relationships are established for the following classes of transactions crossing PI7C7300D:

Posted write transactions, comprised of memory write and memory write and invalidate transactions.

Posted write transactions complete at the source before they complete at the destination; that is, data is written into intermediate data buffers before it reaches the target.

Delayed write request transactions, comprised of I/O write and configuration write transactions.

Delayed write requests are terminated by target retry on the initiator bus and are queued in the delayed transaction queue. A delayed write transaction must complete on the target bus before it completes on the initiator bus.

Delayed write completion transactions, comprised of I/O write and configuration write transactions.

Delayed write completion transactions complete on the target bus, and the target response is queued in the buffers. A delayed write completion transaction proceeds in the direction opposite that of the original delayed write request; that is, a delayed write completion transaction proceeds from the target bus to the initiator bus.

Delayed read request transactions, comprised of all memory read, I/O read, and configuration read transactions.

Delayed read requests are terminated by target retry on the initiator bus and are queued in the delayed transaction queue.

Delayed read completion transactions, comprised of all memory read, I/O read, & configuration read transactions.

Delayed read completion transactions complete on the target bus, and the read data is queued in the read data buffers. A delayed read completion transaction proceeds in the direction opposite that of the original delayed read request; that is, a delayed read completion transaction proceeds from the target bus to the initiator bus.

PI7C7300D does not combine or merge write transactions:

- PI7C7300D does not combine separate write transactions into a single write transaction—this optimization is best implemented in the originating master.
- PI7C7300D does not merge bytes on separate masked write transactions to the same DWORD address—this optimization is also best implemented in the originating master.
- PI7C7300D does not collapse sequential write transactions to the same address into a single write transaction—the PCI Local Bus Specification does not permit this combining of transactions.

6.2 GENERAL ORDERING GUIDELINES

Independent transactions on primary and secondary buses have a relationship only when those transactions cross PI7C7300D.

The following general ordering guidelines govern transactions crossing PI7C7300D:

- The ordering relationship of a transaction with respect to other transactions is determined when the transaction completes, that is, when a transaction ends with a termination other than target retry.
- Requests terminated with target retry can be accepted and completed in any order with respect to other transactions that have been terminated with target retry. If the order of completion of delayed requests is important, the initiator should not start a second delayed transaction until the first one has been completed. If more than one delayed transaction is initiated, the initiator should repeat all delayed transaction requests, using some fairness algorithm. Repeating a delayed transaction cannot be contingent on completion of another delayed transaction. Otherwise, a deadlock can occur.
- Write transactions flowing in one direction have no ordering requirements with respect to write transactions flowing in the other direction. PI7C7300D can accept posted write transactions on both interfaces at the same time, as well as initiate posted write transactions on both interfaces at the same time.
- The acceptance of a posted memory write transaction as a target can never be contingent on the completion of a non-locked, non-posted transaction as a master. This is true for PI7C7300D and must also be true for other bus agents. Otherwise, a deadlock can occur.
- PI7C7300D accepts posted write transactions, regardless of the state of completion of any delayed transactions being forwarded across PI7C7300D.

6.3 ORDERING RULES

Table 6-1 shows the ordering relationships of all the transactions and refers by number to the ordering rules that follow.

Table 6-1 SUMMARY OF TRANSACTION ORDERING

Pass	Posted Write	Delayed Read Request	Delayed Write Request	Delayed Read Completion	Delayed Write Completion
Posted Write	No ¹	Yes ⁵	Yes ⁵	Yes ⁵	Yes ⁵
Delayed Read Request	No ²	No	No	Yes	Yes

Pass		Posted Write	Delayed Read Request	Delayed Write Request	Delayed Read Completion	Delayed Write Completion
Delayed Write Request		No ⁴	No	No	Yes	Yes
Delayed Read Completion	Read	No ³	Yes	Yes	No	No
Delayed Write Completion	Write	Yes	Yes	Yes	No	No

Note: The superscript accompanying some of the table entries refers to any applicable ordering rule listed in this section. Many entries are not governed by these ordering rules; therefore, the implementation can choose whether or not the transactions pass each other. The entries without superscripts reflect the PI7C7300D's implementation choices.

The following ordering rules describe the transaction relationships. Each ordering rule is followed by an explanation, and the ordering rules are referred to by number in Table 6-1. These ordering rules apply to posted write transactions, delayed write and read requests, and delayed write and read completion transactions crossing PI7C7300D in the same direction. Note that delayed completion transactions cross PI7C7300D in the direction opposite that of the corresponding delayed requests.

1. Posted write transactions must complete on the target bus in the order in which they were received on the initiator bus. The subsequent posted write transaction can be setting a flag that covers the data in the first posted write transaction; if the second transaction were to complete before the first transaction, a device checking the flag could subsequently consume stale data.
2. A delayed read request traveling in the same direction as a previously queued posted write transaction must push the posted write data ahead of it. The posted write transaction must complete on the target bus before the delayed read request can be attempted on the target bus. The read transaction can be to the same location as the write data, so if the read transaction were to pass the write transaction, it would return stale data.
3. A delayed read completion must "pull" ahead of previously queued posted write data traveling in the same direction. In this case, the read data is traveling in the same direction as the write data, and the initiator of the read transaction is on the same side of PI7C7300D as the target of the write transaction. The posted write transaction must complete to the target before the read data is returned to the initiator. The read transaction can be a reading to a status register of the initiator of the posted write data and therefore should not complete until the write transaction is complete.
4. Delayed write requests cannot pass previously queued posted write data. For posted memory write transactions, the delayed write transaction can set a flag that covers the data in the posted write transaction. If the delayed write request were to complete before the earlier posted write transaction, a device checking the flag could subsequently consume stale data.
5. Posted write transactions must be given opportunities to pass delayed read and write requests and completions. Otherwise, deadlocks may occur when some bridges which support delayed transactions and other bridges which do not support delayed transactions are being used in the same system. A fairness algorithm is used to arbitrate between the posted write queue and the delayed transaction queue.

6.4 DATA SYNCHRONIZATION

Data synchronization refers to the relationship between interrupt signaling and data delivery. The *PCI Local Bus Specification, Revision 2.2*, provides the following alternative methods for synchronizing data and interrupts:

- The device signaling the interrupt performs a read of the data just written (software).
- The device driver performs a read operation to any register in the interrupting device before accessing data written by the device (software).
- System hardware guarantees that write buffers are flushed before interrupts are forwarded.

PI7C7300D does not have a hardware mechanism to guarantee data synchronization for posted write transactions. Therefore, all posted write transactions must be followed by a read operation, either from the device to the location just written (or some other location along the same path), or from the device driver to one of the device registers.

7 ERROR HANDLING

PI7C7300D checks, forwards, and generates parity on both the primary and secondary interfaces. To maintain transparency, PI7C7300D always tries to forward the existing parity condition on one bus to the other bus, along with address and data. PI7C100 always attempts to be transparent when reporting errors, but this is not always possible, given the presence of posted data and delayed transactions.

To support error reporting on the PCI bus, PI7C7300D implements the following:

- PERR# and SERR# signals on both the primary and secondary interfaces
- Primary status and secondary status registers
- The device-specific P_SERR# event disable register

This chapter provides detailed information about how PI7C7300D handles errors. It also describes error status reporting and error operation disabling.

7.1 ADDRESS PARITY ERRORS

PI7C7300D checks address parity for all transactions on both buses, for all address and all bus commands. When PI7C7300D detects an address parity error on the primary interface, the following events occur:

- If the parity error response bit is set in the command register, PI7C7300D does not claim the transaction with P_DEVSEL#; this may allow the transaction to terminate in a master abort. If parity error response bit is not set, PI7C7300D proceeds normally and accepts the transaction if it is directed to or across PI7C7300D.
- PI7C7300D sets the detected parity error bit in the status register.
- PI7C7300D asserts P_SERR# and sets signaled system error bit in the status register, if both the following conditions are met:

- The SERR# enable bit is set in the command register.
- The parity error response bit is set in the command register.

When PI7C7300D detects an address parity error on the secondary interface, the following events occur:

- If the parity error response bit is set in the bridge control register, PI7C7300D does not claim the transaction with S1_DEVSEL# or S2_DEVSEL#; this may allow the transaction to terminate in a master abort. If parity error response bit is not set, PI7C7300D proceeds normally and accepts transaction if it is directed to or across PI7C7300D.
- PI7C7300D sets the detected parity error bit in the secondary status register.
- PI7C7300D asserts P_SERR# and sets signaled system error bit in status register, if both of the following conditions are met:
 - The SERR# enable bit is set in the command register.
 - The parity error response bit is set in the bridge control register.

7.2 DATA PARITY ERRORS

When forwarding transactions, PI7C7300D attempts to pass the data parity condition from one interface to the other unchanged, whenever possible, to allow the master and target devices to handle the error condition.

The following sections describe, for each type of transaction, the sequence of events that occurs when a parity error is detected and the way in which the parity condition is forwarded across PI7C7300D.

7.2.1 CONFIGURATION WRITE TRANSACTIONS TO CONFIGURATION SPACE

When PI7C7300D detects a data parity error during a Type 0 configuration write transaction to PI7C7300D configuration space, the following events occur:

- If the parity error response bit is set in the command register, PI7C7300D asserts P_TRDY# and writes the data to the configuration register. PI7C7300D also asserts P_PERR#. If the parity error response bit is not set, PI7C7300D does not assert P_PERR#.
- PI7C7300D sets the detected parity error bit in the status register, regardless of the state of the parity error response bit.

7.2.2 READ TRANSACTIONS

When PI7C7300D detects a parity error during a read transaction, the target drives data and data parity, and the initiator checks parity and conditionally asserts PERR#. For downstream transactions, when PI7C7300D detects a read data parity error on the secondary bus, the following events occur:

- PI7C7300D asserts S_PERR# two cycles following the data transfer, if the secondary interface parity error response bit is set in the bridge control register.
- PI7C7300D sets the detected parity error bit in the secondary status register.
- PI7C7300D sets the data parity detected bit in the secondary status register, if the secondary interface parity error response bit is set in the bridge control register.
- PI7C7300D forwards the bad parity with the data back to the initiator on the primary bus. If the data with the bad parity is pre-fetched and is not read by the initiator on the primary bus, the data is discarded and the data with bad parity is not returned to the initiator.
- PI7C7300D completes the transaction normally.

For upstream transactions, when PI7C7300D detects a read data parity error on the primary bus, the following events occur:

- PI7C7300D asserts P_PERR# two cycles following the data transfer, if the primary interface parity error response bit is set in the command register.
- PI7C7300D sets the detected parity error bit in the primary status register.
- PI7C7300D sets the data parity detected bit in the primary status register, if the primary interface parity-error-response bit is set in the command register.
- PI7C7300D forwards the bad parity with the data back to the initiator on the secondary bus. If the data with the bad parity is pre-fetched and is not read by the initiator on the secondary bus, the data is discarded and the data with bad parity is not returned to the initiator.
- PI7C7300D completes the transaction normally.

PI7C7300D returns to the initiator the data and parity that was received from the target. When the initiator detects a parity error on this read data and is enabled to report it, the initiator asserts PERR# two cycles after the data transfer occurs. It is assumed that the initiator takes responsibility for handling a parity error condition; therefore, when PI7C7300D detects PERR# asserted while returning read data to the initiator, PI7C7300D does not take any further action and completes the transaction normally.

7.2.3 DELAYED WRITE TRANSACTIONS

When PI7C7300D detects a data parity error during a delayed write transaction, the initiator drives data and data parity, and the target checks parity and conditionally asserts PERR#.

For delayed write transactions, a parity error can occur at the following times:

- During the original delayed write request transaction
- When the initiator repeats the delayed write request transaction
- When PI7C7300D completes the delayed write transaction to the target

When a delayed write transaction is normally queued, the address, command, address parity, data, byte enable bits, and data parity are all captured and a target retry is returned to the initiator. When PI7C7300D detects a parity error on the write data for the initial delayed write request transaction, the following events occur:

- If the parity-error-response bit corresponding to the initiator bus is set, PI7C7300D asserts TRDY# to the initiator and the transaction is not queued. If multiple data phases are requested, STOP# is also asserted to cause a target disconnect. Two cycles after the data transfer, PI7C7300D also asserts PERR#.

If the parity-error-response bit is not set, PI7C7300D returns a target retry. It queues the transaction as usual. PI7C7300D does not assert PERR#. In this case, the initiator repeats the transaction.

- PI7C7300D sets the detected-parity-error bit in the status register corresponding to the initiator bus, regardless of the state of the parity-error-response bit.

Note: If parity checking is turned off and data parity errors have occurred for queued or subsequent delayed write transactions on the initiator bus, it is possible that the initiator's re-attempts of the write transaction may not match the original queued delayed write information contained in the delayed transaction queue. In this case, a master timeout condition may occur, possibly resulting in a system error (P_SERR# assertion).

For downstream transactions, when PI7C7300D is delivering data to the target on the secondary bus and S_PERR# is asserted by the target, the following events occur:

- PI7C7300D sets the secondary interface data parity detected bit in the secondary status register, if the secondary parity error response bit is set in the bridge control register.
- PI7C7300D captures the parity error condition to forward it back to the initiator on the primary bus.

Similarly, for upstream transactions, when PI7C7300D is delivering data to the target on the primary bus and P_PERR# is asserted by the target, the following events occur:

- PI7C7300D sets the primary interface data-parity-detected bit in the status register, if the primary parity-error-response bit is set in the command register.
- PI7C7300D captures the parity error condition to forward it back to the initiator on the secondary bus.

A delayed write transaction is completed on the initiator bus when the initiator repeats the write transaction with the same address, command, data, and byte enable bits as the delayed write command that is at the head of the posted data queue. Note that the parity bit is not compared when determining whether the transaction matches those in the delayed transaction queues.

Two cases must be considered:

- When parity error is detected on the initiator bus on a subsequent re-attempt of the transaction and was not detected on the target bus
- When parity error is forwarded back from the target bus

For downstream delayed write transactions, when the parity error is detected on the initiator bus and PI7C7300D has write status to return, the following events occur:

- PI7C7300D first asserts P_TRDY# and then asserts P_PERR# two cycles later, if the primary interface parity-error-response bit is set in the command register.

- PI7C7300D sets the primary interface parity-error-detected bit in the status register.
- Because there was not an exact data and parity match, the write status is not returned and the transaction remains in the queue.

Similarly, for upstream delayed write transactions, when the parity error is detected on the initiator bus and PI7C7300D has write status to return, the following events occur:

- PI7C7300D first asserts S1_TRDY# or S2_TRDY# and then asserts S_PERR# two cycles later, if the secondary interface parity-error-response bit is set in the bridge control register (offset 3Ch).
- PI7C7300D sets the secondary interface parity-error-detected bit in the secondary status register.
- Because there was not an exact data and parity match, the write status is not returned and the transaction remains in the queue.

For downstream transactions, where the parity error is being passed back from the target bus and the parity error condition was not originally detected on the initiator bus, the following events occur:

- PI7C7300D asserts P_PERR# two cycles after the data transfer, if the following are both true:
 - The parity-error-response bit is set in the command register of the primary interface.
 - The parity-error-response bit is set in the bridge control register of the secondary interface.
- PI7C7300D completes the transaction normally.

For upstream transactions, when the parity error is being passed back from the target bus and the parity error condition was not originally detected on the initiator bus, the following events occur:

- PI7C7300D asserts S_PERR# two cycles after the data transfer, if the following are both true:
 - The parity error response bit is set in the command register of the primary interface.
 - The parity error response bit is set in the bridge control register of the secondary interface.
- PI7C7300D completes the transaction normally.

7.2.4 POSTED WRITE TRANSACTIONS

During downstream posted write transactions, when PI7C7300D responds as a target, it detects a data parity error on the initiator (primary) bus and the following events occur:

- PI7C7300D asserts P_PERR# two cycles after the data transfer, if the parity error response bit is set in the command register of primary interface.
- PI7C7300D sets the parity error detected bit in the status register of the primary interface.
- PI7C7300D captures and forwards the bad parity condition to the secondary bus.
- PI7C7300D completes the transaction normally.

Similarly, during upstream posted write transactions, when PI7C7300D responds as a target, it detects a data parity error on the initiator (secondary) bus, the following events occur:

- PI7C7300D asserts S_PERR# two cycles after the data transfer, if the parity error response bit is set in the bridge control register of the secondary interface.
- PI7C7300D sets the parity error detected bit in the status register of the secondary interface.
- PI7C7300D captures and forwards the bad parity condition to the primary bus.
- PI7C7300D completes the transaction normally.

During downstream write transactions, when a data parity error is reported on the target (secondary) bus by the target's assertion of S_PERR#, the following events occur:

- PI7C7300D sets the data parity detected bit in the status register of secondary interface, if the parity error response bit is set in the bridge control register of the secondary interface.
- PI7C7300D asserts P_SERR# and sets the signaled system error bit in the status register, if all the following conditions are met:
 - The SERR# enable bit is set in the command register.
 - The posted write parity error bit of P_SERR# event disable register is not set.
 - The parity error response bit is set in the bridge control register of the secondary interface.
 - The parity error response bit is set in the command register of the primary interface.
 - PI7C7300D has not detected the parity error on the primary (initiator) bus which the parity error is not forwarded from the primary bus to the secondary bus.

During upstream write transactions, when a data parity error is reported on the target (primary) bus by the target's assertion of P_PERR#, the following events occur:

- PI7C7300D sets the data parity detected bit in the status register, if the parity error response bit is set in the command register of the primary interface.
- PI7C7300D asserts P_SERR# and sets the signaled system error bit in the status register, if all the following conditions are met:
 - The SERR# enable bit is set in the command register.
 - The parity error response bit is set in the bridge control register of the secondary interface.
 - The parity error response bit is set in the command register of the primary interface.
 - PI7C7300D has not detected the parity error on the secondary (initiator) bus which the parity error is not forwarded from the secondary bus to the primary bus.

Assertion of P_SERR# is used to signal the parity error condition when the initiator does not know that the error occurred. Because the data has already been delivered with no errors, there is no other way to signal this information back to the initiator. If the parity error has forwarded from the initiating bus to the target bus, P_SERR# will not be asserted.

7.3 DATA PARITY ERROR REPORTING SUMMARY

In the previous sections, the responses of PI7C7300D to data parity errors are presented according to the type of transaction in progress. This section organizes the responses of PI7C7300D to data parity errors according to the status bits that PI7C7300D sets and the signals that it asserts.

Table 7-1 shows setting the detected parity error bit in the status register, corresponding to the primary interface. This bit is set when PI7C7300D detects a parity error on the primary interface.

Table 7-1 SETTING THE PRIMARY INTERFACE DETECTED PARITY ERROR BIT

Primary Detected Parity Error Bit	Transaction Type	Direction	Bus Where Error Was Detected	Primary/Secondary Parity Error Response Bits
0	Read	Downstream	Primary	x / x
0	Read	Downstream	Secondary	x / x
1	Read	Upstream	Primary	x / x
0	Read	Upstream	Secondary	x / x
1	Posted Write	Downstream	Primary	x / x
0	Posted Write	Downstream	Secondary	x / x
0	Posted Write	Upstream	Primary	x / x
0	Posted Write	Upstream	Secondary	x / x
1	Delayed Write	Downstream	Primary	x / x
0	Delayed Write	Downstream	Secondary	x / x
0	Delayed Write	Upstream	Primary	x / x
0	Delayed Write	Upstream	Secondary	x / x

X = don't care

Table 7-2 shows setting the detected parity error bit in the secondary status register, corresponding to the secondary interface. This bit is set when PI7C7300D detects a parity error on the secondary interface.

Table 7-2 SETTING SECONDARY INTERFACE DETECTED PARITY ERROR BIT

Secondary Detected Parity Error Bit	Transaction Type	Direction	Bus Where Error Was Detected	Primary/Secondary Parity Error Response Bits
0	Read	Downstream	Primary	x / x
1	Read	Downstream	Secondary	x / x
0	Read	Upstream	Primary	x / x
0	Read	Upstream	Secondary	x / x
0	Posted Write	Downstream	Primary	x / x
0	Posted Write	Downstream	Secondary	x / x
0	Posted Write	Upstream	Primary	x / x
1	Posted Write	Upstream	Secondary	x / x
0	Delayed Write	Downstream	Primary	x / x
0	Delayed Write	Downstream	Secondary	x / x
0	Delayed Write	Upstream	Primary	x / x
1	Delayed Write	Upstream	Secondary	x / x

X = don't care

Table 7-3 shows setting data parity detected bit in the primary interface's status register. This bit is set under the following conditions:

- PI7C7300D must be a master on the primary bus.
- The parity error response bit in the command register, corresponding to the primary interface, must be set.
- The P_PERR# signal is detected asserted or a parity error is detected on the primary bus.

Table 7-3 SETTING PRIMARY INTERFACE DATA PARITY ERROR DETECTED BIT

Primary Data Parity Bit	Transaction Type	Direction	Bus Where Error Was Detected	Primary / Secondary Parity Error Response Bits
0	Read	Downstream	Primary	x / x
0	Read	Downstream	Secondary	x / x
1	Read	Upstream	Primary	1 / x
0	Read	Upstream	Secondary	x / x
0	Posted Write	Downstream	Primary	x / x
0	Posted Write	Downstream	Secondary	x / x
1	Posted Write	Upstream	Primary	1 / x
0	Posted Write	Upstream	Secondary	x / x
0	Delayed Write	Downstream	Primary	x / x
0	Delayed Write	Downstream	Secondary	x / x
1	Delayed Write	Upstream	Primary	1 / x
0	Delayed Write	Upstream	Secondary	x / x

X = don't care

Table 7-4 shows setting the data parity detected bit in the status register of secondary interface. This bit is set under the following conditions:

- The PI7C7300D must be a master on the secondary bus.
- The parity error response bit must be set in the bridge control register of secondary interface.
- The S_PERR# signal is detected asserted or a parity error is detected on the secondary bus.

Table 7-4 SETTING SECONDARY INTERFACE DATA PARITY ERROR DETECTED BIT

Secondary Detected Parity Detected Bit	Transaction Type	Direction	Bus Where Error Was Detected	Primary / Secondary Parity Error Response Bits
0	Read	Downstream	Primary	x / x
1	Read	Downstream	Secondary	x / 1
0	Read	Upstream	Primary	x / x
0	Read	Upstream	Secondary	x / x
0	Posted Write	Downstream	Primary	x / x
1	Posted Write	Downstream	Secondary	x / 1
0	Posted Write	Upstream	Primary	x / x
0	Posted Write	Upstream	Secondary	x / x
0	Delayed Write	Downstream	Primary	x / x
1	Delayed Write	Downstream	Secondary	x / 1
0	Delayed Write	Upstream	Primary	x / x
0	Delayed Write	Upstream	Secondary	x / x

X = don't care

Table 7-5 shows assertion of P_PERR#. This signal is set under the following conditions:

- PI7C7300D is either the target of a write transaction or the initiator of a read transaction on the primary bus.
- The parity-error-response bit must be set in the command register of primary interface.
- PI7C7300D detects a data parity error on the primary bus or detects S_PERR# asserted during the completion phase of a downstream delayed write transaction on the target (secondary) bus.

Table 7-5 ASSERTION OF P_PERR#

P_PERR#	Transaction Type	Direction	Bus Where Error Was Detected	Primary/Secondary Parity Error Response Bits
1 (de-asserted)	Read	Downstream	Primary	x / x
1	Read	Downstream	Secondary	x / x
0 (asserted)	Read	Upstream	Primary	1 / x
1	Read	Upstream	Secondary	x / x
0	Posted Write	Downstream	Primary	1 / x
1	Posted Write	Downstream	Secondary	x / x
1	Posted Write	Upstream	Primary	x / x
1	Posted Write	Upstream	Secondary	x / x
0	Delayed Write	Downstream	Primary	1 / x
0 ²	Delayed Write	Downstream	Secondary	1 / 1
1	Delayed Write	Upstream	Primary	x / x
1	Delayed Write	Upstream	Secondary	x / x

X = don't care

²The parity error was detected on the target (secondary) bus but not on the initiator (primary) bus.

Table 7-6 shows assertion of S_PERR# that is set under the following conditions:

- PI7C7300D is either the target of a write transaction or the initiator of a read transaction on the secondary bus.
- The parity error response bit must be set in the bridge control register of secondary interface.
- PI7C7300D detects a data parity error on the secondary bus or detects P_PERR# asserted during the completion phase of an upstream delayed write transaction on the target (primary) bus.

Table 7-6 ASSERTION OF S_PERR#

S_PERR#	Transaction Type	Direction	Bus Where Error Was Detected	Primary/Secondary Parity Error Response Bits
1 (de-asserted)	Read	Downstream	Primary	x / x
0 (asserted)	Read	Downstream	Secondary	x / 1
1	Read	Upstream	Primary	x / x
1	Read	Upstream	Secondary	x / x
1	Posted Write	Downstream	Primary	x / x
1	Posted Write	Downstream	Secondary	x / x
1	Posted Write	Upstream	Primary	x / x
0	Posted Write	Upstream	Secondary	x / 1
1	Delayed Write	Downstream	Primary	x / x
1	Delayed Write	Downstream	Secondary	x / x
0 ²	Delayed Write	Upstream	Primary	1 / 1
0	Delayed Write	Upstream	Secondary	x / 1

X = don't care

²The parity error was detected on the target (secondary) bus but not on the initiator (primary) bus.

Table 7-7 shows assertion of P_SERR#. This signal is set under the following conditions:

- PI7C7300D has detected P_PERR# asserted on an upstream posted write transaction or S_PERR# asserted on a downstream posted write transaction.
- PI7C7300D did not detect the parity error as a target of the posted write transaction.
- The parity error response bit on the command register and the parity error response bit on the bridge control register must both be set.
- The SERR# enable bit must be set in the command register.

Table 7-7 ASSERTION OF P_SERR# FOR DATA PARITY ERRORS

P_SERR#	Transaction Type	Direction	Bus Where Error Was Detected	Primary / Secondary Parity Error Response Bits
1 (de-asserted)	Read	Downstream	Primary	x / x
1	Read	Downstream	Secondary	x / x
1	Read	Upstream	Primary	x / x
1	Read	Upstream	Secondary	x / x
1	Posted Write	Downstream	Primary	x / x
0 ² (asserted)	Posted Write	Downstream	Secondary	1 / 1
0 ³	Posted Write	Upstream	Primary	1 / 1
1	Posted Write	Upstream	Secondary	x / x
1	Delayed Write	Downstream	Primary	x / x
1	Delayed Write	Downstream	Secondary	x / x
1	Delayed Write	Upstream	Primary	x / x
1	Delayed Write	Upstream	Secondary	x / x

X = don't care

²The parity error was detected on the target (secondary) bus but not on the initiator (primary) bus.

³The parity error was detected on the target (primary) bus but not on the initiator (secondary) bus.

7.4 SYSTEM ERROR (SERR#) REPORTING

PI7C7300D uses the P_SERR# signal to report conditionally a number of system error conditions in addition to the special case parity error conditions described in Section 7.2.3.

Whenever assertion of P_SERR# is discussed in this document, it is assumed that the following conditions apply:

- For PI7C7300D to assert P_SERR# for any reason, the SERR# enable bit must be set in the command register.
- Whenever PI7C7300D asserts P_SERR#, PI7C7300D must also set the signaled system error bit in the status register.

In compliance with the PCI-to-PCI Bridge Architecture Specification, PI7C7300D asserts P_SERR# when it detects the secondary SERR# input, S_SERR#, asserted and the SERR# forward enable bit is set in the bridge control register. In addition, PI7C7300D also sets the received system error bit in the secondary status register.

PI7C7300D also conditionally asserts P_SERR# for any of the following reasons:

- Target abort detected during posted write transaction
- Master abort detected during posted write transaction
- Posted write data discarded after 2^{24} (default) attempts to deliver (2^{24} target retries received)
- Parity error reported on target bus during posted write transaction (see previous section)
- Delayed write data discarded after 2^{24} (default) attempts to deliver (2^{24} target retries received)
- Delayed read data cannot be transferred from target after 2^{24} (default) attempts (2^{24} target retries received)
- Master timeout on delayed transaction

The device-specific P_SERR# status register reports the reason for the assertion of P_SERR#. Most of these events have additional device-specific disable bits in the P_SERR# event disable register that make it possible to mask out P_SERR# assertion for specific events. The master timeout condition has a SERR# enable bit for that event in the bridge control register and therefore does not have a device-specific disable bit.

8 EXCLUSIVE ACCESS

This chapter describes the use of the LOCK# signal to implement exclusive access to a target for transactions that cross PI7C7300D.

8.1 CONCURRENT LOCKS

The primary and secondary bus lock mechanisms operate concurrently except when a locked transaction crosses PI7C7300D. A primary master can lock a primary target without affecting the status of the lock on the secondary bus, and vice versa. This means that a primary master can lock a primary target at the same time that a secondary master locks a secondary target.

8.2 ACQUIRING EXCLUSIVE ACCESS ACROSS PI7C7300D

For any PCI bus, before acquiring access to the LOCK# signal and starting a series of locked transactions, the initiator must first check that both of the following conditions are met:

- The PCI bus must be idle.
- The LOCK# signal must be de-asserted.

The initiator leaves the LOCK# signal de-asserted during the address phase and asserts LOCK# one clock cycle later. Once a data transfer is completed from the target, the target lock has been achieved.

8.2.1 LOCKED TRANSACTIONS IN DOWSTREAM DIRECTION

Locked transactions can cross PI7C7300D only in the downstream direction, from the primary bus to the secondary bus.

When the target resides on another PCI bus, the master must acquire not only the lock on its own PCI bus but also the lock on every bus between its bus and the target's bus. When PI7C7300D detects on the primary bus, an initial locked transaction intended for a target on the secondary bus, PI7C7300D samples the address, transaction type, byte enable bits, and parity, as described in Section 4.6.4. It also samples the lock signal. If there is a lock established between 2 ports or the target bus is already locked by another master, then the current lock cycle is retried without forward. Because a target retry is signaled to the initiator, the initiator must relinquish the lock on the primary bus, and therefore the lock is not yet established.

The first locked transaction must be a memory read transaction. Subsequent locked transactions can be memory read or memory write transactions. Posted memory write transactions that are a part of the locked transaction sequence are still posted. Memory read transactions that are a part of the locked transaction sequence are not pre-fetched.

When the locked delayed memory read request is queued, PI7C7300D does not queue any more transactions until the locked sequence is finished. PI7C7300D signals a target retry to all transactions initiated subsequent to the locked read transaction that are intended for targets on the other side of PI7C7300D. PI7C7300D allows any transactions queued before the locked transaction to complete before initiating the locked transaction.

When the locked delayed memory read request transaction moves to the head of the delayed transaction queue, PI7C7300D initiates the transaction as a locked read transaction by de-asserting LOCK# on the target bus during the first address phase, and by asserting LOCK# one cycle later. If LOCK# is already asserted (used by another initiator), PI7C7300D waits to request access to the secondary bus until LOCK# is de-asserted when the target bus is idle. Note that the existing lock on the target bus could not have crossed PI7C7300D. Otherwise, the pending queued locked transaction would not have been queued. When PI7C7300D is able to complete a data transfer with the locked read transaction, the lock is established on the secondary bus.

When the initiator repeats the locked read transaction on the primary bus with the same address, transaction type, and byte enable bits, PI7C7300D transfers the read data back to the initiator, and the lock is then also established on the primary bus.

For PI7C7300D to recognize and respond to the initiator, the initiator's subsequent attempts of the read transaction must use the locked transaction sequence (de-assert LOCK# during address phase, and assert LOCK# one cycle later). If the LOCK# sequence is not used in subsequent attempts, a master timeout condition may result. When a master timeout condition occurs, SERR# is conditionally asserted (see Section 7.4), the read data and queued read transaction are discarded, and the LOCK# signal is de-asserted on the target bus.

Once the intended target has been locked, any subsequent locked transactions initiated on the initiator bus that are forwarded by PI7C7300D are driven as locked transactions on the target bus.

The first transaction to establish LOCK# must be Memory Read. If the first transaction is not Memory read, the following transactions behave accordingly:

- Type 0 Configuration Read/Write induces master abort
- Type 1 Configuration Read/Write induces master abort
- I/O Read induces master abort

- I/O Write induces master abort
- Memory Write induces master abort

When PI7C7300D receives a target abort or a master abort in response to the delayed locked read transaction, this status is passed back to the initiator, and no locks are established on either the target or the initiator bus. PI7C7300D resumes forwarding unlocked transactions in both directions.

8.2.2 LOCKED TRANSACTION IN UPSTREAM DIRECTION

PI7C7300D ignores upstream lock and transactions. PI7C7300D will pass these transactions as normal transactions without lock established.

8.3 ENDING EXCLUSIVE ACCESS

After the lock has been acquired on both initiator and target buses, PI7C7300D must maintain the lock on the target bus for any subsequent locked transactions until the initiator relinquishes the lock.

The only time a target-retry causes the lock to be relinquished is on the first transaction of a locked sequence. On subsequent transactions in the sequence, the target retry has no effect on the status of the lock signal.

An established target lock is maintained until the initiator relinquishes the lock. PI7C7300D does not know whether the current transaction is the last one in a sequence of locked transactions until the initiator de-asserts the LOCK# signal at end of the transaction.

When the last locked transaction is a delayed transaction, PI7C7300D has already completed the transaction on the target bus. In this example, as soon as PI7C7300D detects that the initiator has relinquished the LOCK# signal by sampling it in the de-asserted state while FRAME# is deasserted, PI7C7300D de-asserts the LOCK# signal on the target bus as soon as possible. Because of this behavior, LOCK# may not be de-asserted until several cycles after the last locked transaction has been completed on the target bus. As soon as PI7C7300D has de-asserted LOCK# to indicate the end of a sequence of locked transactions, it resumes forwarding unlocked transactions.

When the last locked transaction is a posted write transaction, PI7C7300D de-asserts LOCK# on the target bus at the end of the transaction because the lock was relinquished at the end of the write transaction on the initiator bus.

When PI7C7300D receives a target abort or a master abort in response to a locked delayed transaction, PI7C7300D returns a target abort or a master abort when the initiator repeats the locked transaction. The initiator must then deassert LOCK# at the end of the transaction. PI7C7300D sets the appropriate status bits, flagging the abnormal target termination condition (see Section 4.8). Normal forwarding of unlocked posted and delayed transactions is resumed.

When PI7C7300D receives a target abort or a master abort in response to a locked posted write transaction, PI7C7300D cannot pass back that status to the initiator. PI7C7300D asserts SERR# on the initiator bus when a target abort or a master abort is received during a locked posted write transaction, if the SERR# enable bit is set in the command register. Signal SERR# is asserted for the master abort condition if the master abort mode bit is set in the bridge control register (see Section 7.4).

9 PCI BUS ARBITRATION

PI7C7300D must arbitrate for use of the primary bus when forwarding upstream transactions. Also, it must arbitrate for use of the secondary bus when forwarding downstream transactions. The arbiter for the primary bus resides external to PI7C7300D, typically on the motherboard. For the secondary PCI bus, PI7C7300D implements an internal arbiter. This arbiter can be disabled, and an external arbiter can be used instead. This chapter describes primary and secondary bus arbitration.

9.1 PRIMARY PCI BUS ARBITRATION

PI7C7300D implements a request output pin, P_REQ#, and a grant input pin, P_GNT#, for primary PCI bus arbitration. PI7C7300D asserts P_REQ# when forwarding transactions upstream; that is, it acts as initiator on the primary PCI bus. As long as at least one pending transaction resides in the queues in the upstream direction, either posted write data or delayed transaction requests, PI7C7300D keeps P_REQ# asserted. However, if a target retry, target disconnect, or a target abort is received in response to a transaction initiated by PI7C7300D on the primary PCI bus, PI7C7300D de-asserts P_REQ# for two PCI clock cycles.

For all cycles through the bridge, P_REQ# is not asserted until the transaction request has been completely queued. When P_GNT# is asserted LOW by the primary bus arbiter after PI7C7300D has asserted P_REQ#, PI7C7300D initiates a transaction on the primary bus during the next PCI clock cycle. When P_GNT# is asserted to PI7C7300D when P_REQ# is not asserted, PI7C7300D parks P_AD, P_CBE, and P_PAR by driving them to valid logic levels. When the primary bus is parked at PI7C7300D and PI7C7300D has a transaction to initiate on the primary bus, PI7C7300D starts the transaction if P_GNT# was asserted during the previous cycle.

9.2 SECONDARY PCI BUS ARBITRATION

PI7C7300D implements an internal secondary PCI bus arbiter. This arbiter supports eight external masters on secondary 1 and seven external masters on secondary 2 in addition to PI7C7300D. The internal arbiter can be disabled, and an external arbiter can be used instead for secondary bus arbitration.

9.2.1 SECONDARY BUS ARBITRATION USING THE INTERNAL ARBITER

To use the internal arbiter, the secondary bus arbiter enable pin, S_CFN#, must be tied LOW. PI7C7300D has eight/seven secondary bus 1/2 request input pins, S1_REQ#[7:0], S2_REQ#[6:0], and has eight/seven secondary bus 1/2 output grant pins, S1_GNT#[7:0], S2_GNT#[6:0], to support external secondary bus masters. The secondary bus request and grant signals are connected internally to the arbiter and are not brought out to external pins when S_CFN# is HIGH.

The secondary arbiter supports a 2-sets programmable 2-level rotating algorithm with each set taking care of 8 requests/ grants. Each set of masters can be assigned to a high priority group and a low priority group. The low priority group as a whole represents one entry in the high priority group; that is, if the high priority group consists of n masters, then in at least every n+1 transactions the highest priority is assigned to the low priority group. Priority rotates evenly among the low priority group. Therefore, members of the high priority group can be serviced n transactions out of n+1, while one member of the low priority group is serviced once every n+1 transactions. **Error! Reference source not found.** shows an example of an internal arbiter where four masters, including PI7C7300D, are in the high priority group, and five masters are in the low priority group. Using this example, if all requests are always asserted, the highest priority rotates among

the masters in the following fashion (high priority members are given in *italics*, low priority members, in **boldface** type): *B*, *m0*, *m1*, *m2*, **m3**, *B*, *m0*, *m1*, *m2*, **m4**, *B*, *m0*, *m1*, *m2*, **m5**, *B*, *m0*, *m1*, *m2*, **m6**, *B*, *m0*, *m1*, *m2*, **m7** and so on.

Figure 9-1 SECONDARY ARBITER EXAMPLE

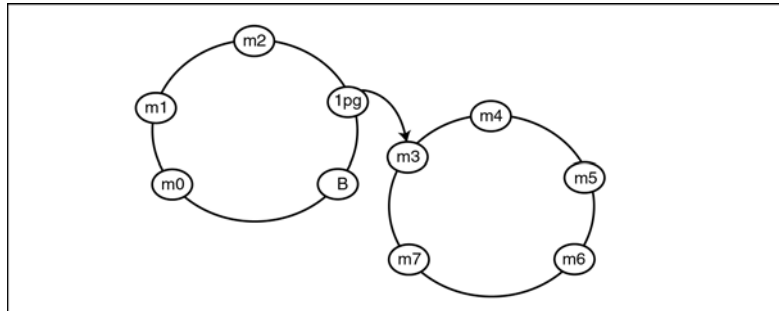

Each bus master, including PI7C7300D, can be configured to be in either the low priority group or the high priority group by setting the corresponding priority bit in the arbiter-control register. The arbiter-control register is located at offset 40h. Each master has a corresponding bit. If the bit is set to 1, the master is assigned to the high priority group. If the bit is set to 0, the master is assigned to the low priority group. If all the masters are assigned to one group, the algorithm defaults to a straight rotating priority among all the masters. After reset, all external masters are assigned to the low priority group, and PI7C7300D is assigned to the high priority group. PI7C7300D receives highest priority on the target bus every other transaction, and priority rotates evenly among the other masters.

Priorities are re-evaluated every time S1_FRAME# or S2_FRAME# is asserted at the start of each new transaction on the secondary PCI bus. From this point until the time that the next transaction starts, the arbiter asserts the grant signal corresponding to the highest priority request that is asserted. If a grant for a particular request is asserted, and a higher priority request subsequently asserts, the arbiter de-asserts the asserted grant signal and asserts the grant corresponding to the new higher priority request on the next PCI clock cycle. When priorities are re-evaluated, the highest priority is assigned to the next highest priority master relative to the master that initiated the previous transaction. The master that initiated the last transaction now has the lowest priority in its group.

If PI7C7300D detects that an initiator has failed to assert S1_FRAME# or S2_FRAME# after 16 cycles of both grant assertion and a secondary idle bus condition, the arbiter de-asserts the grant. That master does not receive any more grants until it deasserts its request for at least one PCI clock cycle.

To prevent bus contention, if the secondary PCI bus is idle, the arbiter never asserts one grant signal in the same PCI cycle in which it deasserts another. It de-asserts one grant and asserts the next grant, no earlier than one PCI clock cycle later. If the secondary PCI bus is busy, that is, either S1_FRAME# (S2_FRAME#) or S1_IRDY# (S2_IRDY#) is asserted, the arbiter can de-assert one grant and assert another grant during the same PCI clock cycle.

9.2.2 PREEMPTION

Preemption can be programmed to be either on or off, with the default to on (offset 4Ch, bit 31=0). Time-to-preempt can be programmed to 8, 16, 32, 64, or 128 (default is 32) clocks.

If the current master occupies the bus and other masters are waiting, the current master will be preempted by removing its grant (GNT#) after the next master waits for the time-to-preempt.

9.2.3 SECONDARY BUS ARBITRATION USING AN EXTERNAL ARBITER

The internal arbiter is disabled when the secondary bus central function control pin, S_CFN#, is tied high. An external arbiter must then be used.

When S_CFN# is tied high, PI7C7300D, reconfigures four pins (two per port) to be external request and grant pins. The S1_GNT#[0] and S2_GNT#[0] pins are reconfigured to be the external request pins because they are output. The S1_REQ#[0] and S2_REQ#[0] pins are reconfigured to be the external grant pins because they are input. When an external arbiter is used, PI7C7300D uses the S1_GNT#[0] or S2_GNT#[0] pin to request the secondary bus. When the reconfigured S1_REQ#[0] and S2_REQ#[0] pin is asserted low after PI7C7300D has asserted S1_GNT#[0] or S2_GNT#[0], PI7C7300D initiates a transaction on the secondary bus one cycle later. If grant is asserted and PI7C7300D has not asserted the request, PI7C7300D parks AD, CBE and PAR pins by driving them to valid logic levels.

The unused secondary bus grants outputs, S_GNT#[7:1] and S_GNT#[6:1] are driven high. The unused secondary bus requests inputs, S1_REQ#[7:1] and S2_REQ#[6:1], should be pulled high.

9.2.4 BUS PARKING

Bus parking refers to driving the AD[31:0], CBE[3:0]#, and PAR lines to a known value while the bus is idle. In general, the device implementing the bus arbiter is responsible for parking the bus or assigning another device to park the bus. A device parks the bus when the bus is idle, its bus grant is asserted, and the device's request is not asserted. The AD and CBE signals should be driven first, with the PAR signal driven one cycle later.

PI7C7300D parks the primary bus only when P_GNT# is asserted, P_REQ# is de-asserted, and the primary PCI bus is idle. When P_GNT# is de-asserted, PI7C7300D 3-states the P_AD, P_CBE, and P_PAR signals on the next PCI clock cycle. If PI7C7300D is parking the primary PCI bus and wants to initiate a transaction on that bus, then PI7C7300D can start the transaction on the next PCI clock cycle by asserting P_FRAME# if P_GNT# is still asserted.

If the internal secondary bus arbiter is enabled, the secondary bus is always parked at the last master that used the PCI bus. That is, PI7C7300D keeps the secondary bus grant asserted to a particular master until a new secondary bus request comes along. After reset, PI7C7300D parks the secondary bus at itself until transactions start occurring on

the secondary bus. If the internal arbiter is disabled, PI7C7300D parks the secondary bus only when the reconfigured grant signal, S_REQ#[0], is asserted and the secondary bus is idle.

10 COMPACT PCI HOT SWAP

Compact PCI (cPCI) Hot Swap (PICMG 2.1, R1.0) defines a process for installing and removing PCI boards from a Compact PCI system without powering down the system. The PI7C7300D is Hot Swap Friendly silicon that supports all the cPCI Hot Swap Capable features and adds support for Software Connection Control. Being Hot Swap Friendly, the PI7C7300D supports the following:

- Compliance with PCI Specification 2.2
- Tolerates V_{CC} from Early Power
- Asynchronous Reset
- Tolerates Precharge Voltage
- I/O Buffers Meet Modified V/I Requirements
- Limited I/O Pin Leakage at Precharge Voltage

When the PI7C7300D resides on the Compact PCI add-in card, the Primary Bus must be the bus that is inserted into the Compact PCI system. To perform the Hot Swap function, the device must be configured according to the *CPCI Hot-Swap Specifications*. For the PI7C7300D, the only path for configuration is through the Primary Bus. The bridge may not be configured through either secondary buses. If the user chooses to use the secondary buses for insertion, an external register needs to be provided for the Hot Swap Control Status Register.

11 CLOCKS

This chapter provides information about the clocks.

11.1 PRIMARY CLOCK INPUTS

PI7C7300D implements a primary clock input for the PCI interface. The primary interface is synchronized to the primary clock input, P_CLK, and the secondary interface is synchronized to the secondary clock. The secondary clock is derived internally from the primary clock, P_CLK, through an internal PLL. PI7C7300D operates at a maximum frequency of 66 MHz.

11.2 SECONDARY CLOCK OUTPUTS

PI7C7300D has 16 secondary clock outputs, S_CLKOUT[15:0] that can be used as clock inputs for up to fifteen external secondary bus devices. The S_CLKOUT[15:0] outputs are derived from P_CLK. The secondary clock edges are delayed from P_CLK edges by a minimum of 0ns. This is the rule for using secondary clocks:

- Each secondary clock output is limited to no more than one load.

12 RESET

This chapter describes the primary interface, secondary interface, and chip reset mechanisms.

12.1 PRIMARY INTERFACE RESET

PI7C7300D has a reset input, P_RESET#. When P_RESET# is asserted, the following events occur:

- PI7C7300D immediately 3-states all primary and secondary PCI interface signals.
- PI7C7300D performs a chip reset.
- Registers that have default values are reset.

P_RESET# asserting and de-asserting edges can be asynchronous to P_CLK and S_CLK. PI7C7300D is not accessible during P_RESET#. After P_RESET# is de-asserted, PI7C7300D remains inaccessible for 16 PCI clocks (T_{rthfa} , page 128 of the PCI Local Bus Specification Rev 2.2) before the first configuration transaction can be accepted.

12.2 SECONDARY INTERFACE RESET

PI7C7300D is responsible for driving the secondary bus reset signals, S1_RESET# and S2_RESET#. PI7C7300D asserts S1_RESET# or S2_RESET# when any of the following conditions is met:

- **Signal P_RESET# is asserted.** Signal S1_RESET# or S2_RESET# remains asserted as long as P_RESET# is asserted and does not de-assert until P_RESET# is de-asserted.
- **The secondary reset bit in the bridge control register is set.** Signal S1_RESET# or S2_RESET# remains asserted until a configuration write operation clears the secondary reset bit.
- **S1_RESET# or S2_RESET# pin is asserted.** When S1_RESET# or S2_RESET# is asserted, PI7C7300D immediately 3-states all the secondary PCI interface signals associated with the Secondary S1 or S2 port. The S1_RESET# or S2_RESET# in asserting and de-asserting edges can be asynchronous to P_CLK.

When S1_RESET# or S2_RESET# is asserted, all secondary PCI interface control signals, including the secondary grant outputs, are immediately 3-stated. Signals S1_AD, S1_CBE[3:0]#, S1_PAR (S2_AD, S2_CBE[3:0]#, S2_PAR) are driven low for the duration of S1_RESET# (S2_RESET#) assertion. All posted write and delayed transaction data buffers are reset. Therefore, any transactions residing inside the buffers at the time of secondary reset are discarded.

When S1_RESET# or S2_RESET# is asserted by means of the secondary reset bit, PI7C7300D remains accessible during secondary interface reset and continues to respond to accesses to its configuration space from the primary interface.

13 SUPPORTED COMMANDS

The PCI command set is given below for the primary and secondary interfaces.

13.1 PRIMARY INTERFACE

P_CBE [3:0] #	Command	Action
0000	Interrupt Acknowledge	Ignore
0001	Special Cycle	Do not claim. Ignore.
0010	I/O Read	<ol style="list-style-type: none"> If address is within pass through I/O range, claim and pass through. Otherwise, do not pass through and do not claim for internal access.
0011	I/O Write	Same as I/O Read.
0100	Reserved	-----
0101	Reserved	-----
0110	Memory Read	<ol style="list-style-type: none"> If address is within pass through memory range, claim and pass through. If address is within pass through memory mapped I/O range, claim and pass through. Otherwise, do not pass through and do not claim for internal access.
0111	Memory Write	Same as Memory Read.
1000	Reserved	-----
1001	Reserved	-----
1010	Configuration Read	<p>I. Type 0 Configuration Read: If the bridge's IDSEL line is asserted, perform function decode and claim if target function is implemented. Otherwise, ignore. If claimed, permit access to target function's configuration registers. Do not pass through under any circumstances.</p> <p>II. Type 1 Configuration Read:</p> <ol style="list-style-type: none"> If the target bus is the bridge's secondary bus: claim and pass through as a Type 0 Configuration Read. If the target bus is a subordinate bus that exists behind the bridge (but not equal to the secondary bus): claim and pass through as a Type 1 Configuration Read. Otherwise, ignore.
1011	Configuration Write	<p>I. Type 0 Configuration Write: same as Configuration Read.</p> <p>II. Type 1 Configuration Write (not special cycle request):</p> <ol style="list-style-type: none"> If the target bus is the bridge's secondary bus: claim and pass through as a Type 0 Configuration Write If the target bus is a subordinate bus that exists behind the bridge (but not equal to the secondary bus): claim and pass through unchanged as a Type 1 Configuration Write. Otherwise, ignore. <p>III. Configuration Write as Special Cycle Request (device = 1Fh, function = 7h)</p>

P_CBE [3:0] #	Command	Action
		<ol style="list-style-type: none"> If the target bus is the bridge's secondary bus: claim and pass through as a special cycle. If the target bus is a subordinate bus that exists behind the bridge (but not equal to the secondary bus): claim and pass through unchanged as a type 1 Configuration Write. Otherwise ignore
1100	Memory Read Multiple	Same as Memory Read
1101	Dual Address Cycle	Supported
1110	Memory Read Line	Same as Memory Read
1111	Memory Write and Invalidate	Same as Memory Read

13.2 SECONDARY INTERFACE

S1_CBE [3:0] # S2_CBE [3:0] #	Command	Action
0000	Interrupt Acknowledge	Ignore
0001	Special Cycle	Do not claim. Ignore.
0010	I/O Read	Same as Primary Interface
0011	I/O Write	Same as I/O Read.
0100	Reserved	-----
0101	Reserved	-----
0110	Memory Read	Same as Primary Interface
0111	Memory Write	Same as Memory Read.
1000	Reserved	-----
1001	Reserved	-----
1010	Configuration Read	Ignore
1011	Configuration Write	<p>I. Type 0 Configuration Write: Ignore</p> <p>II. Type 1 Configuration Write (not special cycle request): Ignore</p> <p>III. Configuration Write as Special Cycle Request (device = 1Fh, function = 7h):</p> <ol style="list-style-type: none"> If the target bus is the bridge's primary bus: claim and pass through as a Special Cycle If the target bus is neither the primary bus nor is it in range of buses defined by the bridge's secondary and subordinate bus registers: claim and pass through unchanged as a Type 1 Configuration Write. If the target bus is not the bridge's primary bus, but is in range of buses defined by the bridge's secondary and subordinate bus registers: ignore.
1100	Memory Read Multiple	Same as Memory Read
1101	Dual Address Cycle	Supported
1110	Memory Read Line	Same as Memory Read
1111	Memory Write and Invalidate	Same as Memory Read

14 CONFIGURATION REGISTERS

As PI7C7300D supports two secondary interfaces, it has two sets of configuration registers that are almost identical and accessed through different function numbers. PCI configuration defines a 64-byte space (configuration header) to define various attributes of the PCI-to-PCI Bridge as shown below. There are two configuration registers:

Configuration Register 1 and Configuration Register 2 corresponding to Secondary Bus 1 and Secondary Bus 2 interfaces respectively. The configuration for the Primary interface is implemented through Configuration Register 1.

14.1 CONFIGURATION REGISTER 1 AND 2

31-24	23-16	15-8	7-0	Address
Device ID		Vendor ID		00h
Status		Command		04h
Class Code			Revision ID	08h
Reserved	Header Type	Primary Latency Timer	Cache Line Size	0Ch
Reserved				10h
Reserved				14h
Secondary Latency Timer	Subordinate Bus Number	Secondary Bus Number	Primary Bus Number	18h
Secondary Status		I/O Limit	I/O Base	1Ch
Memory Limit		Memory Base		20h
Prefetchable Memory Limit		Prefetchable Memory Base		24h
Prefetchable Base Upper 32-bit				28h
Prefetchable Limit Upper 32-bit				2Ch
I/O Limit Upper 16-bit		I/O Base Upper 16-bit		30h
Reserved		ECP Pointer		34h
Reserved				38h
Bridge Control		Reserved		3Ch
Arbiter Control		Diagnostic / Chip Control		40h
Reserved				44h
Upstream Memory Control		Reserved		48h
Hot Swap Switch Time Slot				4Ch
Upstream (S1 or S2 to P) Memory Limit		Upstream (S1 or S2 to P) Memory Base		50h
Upstream (S1 or S2 to P) Memory Base Upper 32-bit				54h
Upstream (S1 or S2 to P) Memory Limit Upper 32-bit				58h
Reserved				5Ch
Reserved				60h
Reserved			P_SERR# Event Disable	64h
Reserved		Secondary Clock Control		68h
Reserved				6Ch
Reserved				70h
Master Timeout Counter		Port Option		74h
Retry Counter				78h
Sampling Timer				7Ch
Secondary Successful I/O Read Counter				80h
Secondary Successful I/O Write Counter				84h
Secondary Successful Memory Read Counter				88h
Secondary Successful Memory Write Counter				8Ch
Primary Successful I/O Read Counter				90h
Primary Successful I/O Write Counter				94h
Primary Successful Memory Read Counter				98h
Primary Successful Memory Write Counter				9Ch
Reserved				A0h-AFh
Chassis Number	Slot Number	Next Pointer	Capability ID	B0h
Reserved				B4h-BFh
Hot Swap Control and Status		Next Pointer	Capability ID	C0h
Reserved				D0h-FFh

14.1.1 VENDOR ID REGISTER – OFFSET 00h

Bit	Function	Type	Description
15:0	Vendor ID	R/O	Identifies Pericom as vendor of this device. Hardwired as 12D8h.

14.1.2 DEVICE ID REGISTER – OFFSET 00h

Configuration Register 1

Bit	Function	Type	Description
31:16	Device ID	R/O	Identifies this device as the PI7C7300D. Hardwired as 71E2h.

Configuration Register 2

Bit	Function	Type	Description
31:16	Device ID	R/O	Identifies this device as the PI7C7300D. Hardwired as 71E3h.

14.1.3 COMMAND REGISTER – OFFSET 04h

Bit	Function	Type	Description
0	I/O Space Enable	R/W	Controls response to I/O access on the primary interface 0: ignore I/O transactions on the primary interface 1: enable response to I/O transactions on the primary interface Reset to 0
1	Memory Space Enable	R/W	Controls response to memory accesses on the primary interface 0: ignore memory transactions on the primary interface 1: enable response to memory transactions on the primary interface Reset to 0
2	Bus Master Enable	R/W	Controls ability to operate as a bus master on the primary interface 0: do not initiate memory or I/O transactions on the primary interface and disable response to memory and I/O transactions on secondary 1 interface 1: enables PI7C7300D to operate as a master on the primary interfaces for memory and I/O transactions forwarded from the secondary interface Reset to 0
3	Special Cycle Enable	R/O	No special cycles defined. Bit is defined as read only and returns 0 when read
4	Memory Write And Invalidate Enable	R/O	Memory write and invalidate not supported. Bit is implemented as read only and returns 0 when read (unless forwarding a transaction for another master)
5	VGA Palette Snoop Enable	R/W	Controls response to VGA compatible palette accesses 0: ignore VGA palette accesses on the primary 1: enable positive decoding response to VGA palette writes on the primary interface with I/O address bits AD[9:0] equal to 3C6h, 3C8h, and 3C9h (inclusive of ISA alias; AD[15:10] are not decoded and may be any value)

Bit	Function	Type	Description
6	Parity Error Response	R/W	Controls response to parity errors 0: PI7C7300D may ignore any parity errors that it detects and continue normal operation 1: PI7C7300D must take its normal action when a parity error is detected Reset to 0
7	Wait Cycle Control	R/O	Controls the ability to perform address / data stepping 0: disable address/data stepping (affects primary and secondary) 1: enable address/data stepping (affects primary and secondary) Reset to 0
8	P_SERR# enable	R/W	Controls the enable for the P_SERR# pin 0: disable the P_SERR# driver 1: enable the P_SERR# driver Reset to 0
9	Fast Back-to-Back Enable	R/W	Controls PI7C7300D's ability to generate fast back-to-back transactions to different devices on the primary interface. 0: no fast back-to-back transactions 1: enable fast back-to-back transactions Reset to 0
15:10	Reserved	R/O	Returns 000000 when read

14.1.4 STATUS REGISTER – OFFSET 04h

Bit	Function	Type	Description
19:16	Reserved	R/O	Reset to 0
20	Capabilities List	R/O	Set to 1 to enable support for the capability list (offset 34h is the pointer to the data structure) Reset to 1
21	66MHz Capable	R/O	Set to 1 to enable 66MHz operation on the primary interface Reset to 1
22	Reserved	R/O	Reset to 0
23	Fast Back-to-Back Capable	R/O	Set to 1 to enable decoding of fast back-to-back transactions on the primary interface to different targets Reset to 1
24	Data Parity Error Detected	R/WC	Set to 1 when P_PERR# is asserted and bit 6 of command register is set Reset to 0
26:25	DEVSEL# timing	R/O	DEVSEL# timing (medium decoding) 00: fast DEVSEL# decoding 01: medium DEVSEL# decoding 10: slow DEVSEL# decoding 11: reserved Reset to 01

Bit	Function	Type	Description
27	Signaled Target Abort	R/WC	Set to 1 (by a target device) whenever a target abort cycle occurs Reset to 0
28	Received Target Abort	R/WC	Set to 1 (by a master device) whenever transactions are terminated with target aborts Reset to 0
29	Received Master Abort	R/WC	Set to 1 (by a master) when transactions are terminated with Master Abort Reset to 0
30	Signaled System Error	R/WC	Set to 1 when P_SERR# is asserted Reset to 0
31	Detected Parity Error	R/WC	Set to 1 when address or data parity error is detected on the primary interface Reset to 0

14.1.5 REVISION ID REGISTER – OFFSET 08h

Bit	Function	Type	Description
7:0	Revision	R/O	Indicates revision number of device. Hardwired to 01h

14.1.6 CLASS CODE REGISTER – OFFEST 08h

Bit	Function	Type	Description
15:8	Programming Interface	R/O	Read as 0 to indicate no programming interfaces have been defined for PCI-to-PCI bridges
23:16	Sub-Class Code	R/O	Read as 04h to indicate device is PCI-to-PCI bridge
31:24	Base Class Code	R/O	Read as 06h to indicate device is a bridge device

14.1.7 CACHE LINE SIZE REGISTER – OFFSET 0Ch

Bit	Function	Type	Description
7:0	Cache Line Size	R/W	Designates the cache line size for the system and is used when terminating memory write and invalidate transactions and when prefetching memory read transactions. Only cache line sizes (in units of 4-byte) which are a power of two are valid (only one bit can be set in this register; only 00h, 01h, 02h, 04h, 08h, and 10h are valid values). Reset to 0

14.1.8 PRIMARY LATENCY TIMER REGISTER – OFFSET 0Ch

Bit	Function	Type	Description
15:8	Primary Latency timer	R/W	This register sets the value for the Master Latency Timer which starts counting when the master asserts FRAME#. Reset to 0

14.1.9 HEADER TYPE REGISTER – OFFSET 0Ch

Configuration Register 1

Bit	Function	Type	Description
23:16	Header Type	R/O	Read as 81h to designate function 0 (multiple function PCI-to-PCI bridge for secondary bus S1)

Configuration Register 2

Bit	Function	Type	Description
23:16	Header Type	R/O	Read as 01h to designate function 1 (single function PCI-to-PCI bridge for secondary bus S2)

14.1.10 PRIMARY BUS NUMBER REGISTER – OFFSET 18h

Bit	Function	Type	Description
7:0	Primary Bus Number	R/W	Indicates the number of the PCI bus to which the primary interface is connected. The value is set in software during configuration. Reset to 0

14.1.11 SECONDARY (S1 or S2) BUS NUMBER REGISTER – OFFSET 18h

Bit	Function	Type	Description
15:8	Secondary (S1 or S2) Bus Number	R/W	Indicates the number of the PCI bus to which the secondary interface (S1 or S2) is connected. The value is set in software during configuration. Reset to 0

14.1.12 SUBORDINATE (S1 or S2) BUS NUMBER REGISTER – OFFSET 18h

Bit	Function	Type	Description
23:16	Subordinate (S1 or S2) Bus Number	R/W	Indicates the number of the PCI bus with the highest number that is subordinate to the bridge. The value is set in software during configuration. Reset to 0

14.1.13 SECONDARY LATENCY TIMER REGISTER – OFFSET 18h

Bit	Function	Type	Description
31:24	Secondary Latency Timer	R/W	Designated in units of PCI bus clocks. Latency timer checks for master accesses on the secondary bus interfaces that remain unclaimed by any target. Reset to 0

14.1.14 I/O BASE REGISTER – OFFSET 1Ch

Bit	Function	Type	Description
3:0	32-bit Indicator	R/O	Read as 01h to indicate 32-bit I/O addressing
7:4	I/O Base Address [15:12]	R/W	Defines the bottom address of the I/O address range for the bridge to determine when to forward I/O transactions from one interface to the other. The upper 4 bits correspond to address bits [15:12] and are writable. The lower 12 bits corresponding to address bits [11:0] are assumed to be 0. The upper 16 bits corresponding to address bits [31:16] are defined in the I/O base address upper 16 bits address register Reset to 0

14.1.15 I/O LIMIT REGISTER – OFFSET 1Ch

Bit	Function	Type	Description
11:8	32-bit Indicator	R/O	Read as 01h to indicate 32-bit I/O addressing
15:12	I/O Base Address [15:12]	R/W	Defines the top address of the I/O address range for the bridge to determine when to forward I/O transactions from one interface to the other. The upper 4 bits correspond to address bits [15:12] and are writable. The lower 12 bits corresponding to address bits [11:0] are assumed to be FFFh. The upper 16 bits corresponding to address bits [31:16] are defined in the I/O base address upper 16 bits address register Reset to 0

14.1.16 SECONDARY STATUS REGISTER – OFFSET 1Ch

Bit	Function	Type	Description
20:16	Reserved	R/O	Reset to 0
21	66MHz Capable	R/O	Set to 1 to enable 66MHz operation on the secondary (S1 or S2) interface Reset to 1
22	Reserved	R/O	Reset to 0
23	Fast Back-to-Back Capable	R/O	Set to 1 to enable decoding of fast back-to-back transactions on the secondary (S1 or S2) interface to different targets Reset to 0
24	Data Parity Error Detected	R/WC	Set to 1 when S1_PERR# or S2_PERR# is asserted and bit 6 of command register is set Reset to 0
26:25	DEVSEL# timing	R/O	DEVSEL# timing (medium decoding) 00: fast DEVSEL# decoding 01: medium DEVSEL# decoding 10: slow DEVSEL# decoding 11: reserved Reset to 01

Bit	Function	Type	Description
27	Signaled Target Abort	R/WC	Set to 1 (by a target device) whenever a target abort cycle occurs on its secondary (S1 or S2) interface Reset to 0
28	Received Target Abort	R/WC	Set to 1 (by a master device) whenever transactions on its secondary (S1 or S2) interface are terminated with target abort Reset to 0
29	Received Master Abort	R/WC	Set to 1 (by a master) when transactions on its secondary (S1 or S2) interface are terminated with Master Abort Reset to 0
30	Received System Error	R/WC	Set to 1 when S1_SERR# or S2_SERR# is asserted Reset to 0
31	Detected Parity Error	R/WC	Set to 1 when address or data parity error is detected on the secondary (S1 or S2) interface Reset to 0

14.1.17 MEMORY BASE REGISTER – OFFSET 20h

Bit	Function	Type	Description
3:0		R/O	Lower four bits of register are read only and return 0. Reset to 0
15:4	Memory Base Address [15:4]	R/W	Defines the bottom address of an address range for the bridge to determine when to forward memory transactions from one interface to the other. The upper 12 bits correspond to address bits [31:20] and are writable. The lower 20 bits corresponding to address bits [19:0] are assumed to be 0. Reset to 0

14.1.18 MEMORY LIMIT REGISTER – OFFSET 20h

Bit	Function	Type	Description
19:16		R/O	Lower four bits of register are read only and return 0. Reset to 0
31:20	Memory Limit Address [31:20]	R/W	Defines the top address of an address range for the bridge to determine when to forward memory transactions from one interface to the other. The upper 12 bits correspond to address bits [31:20] and are writable. The lower 20 bits corresponding to address bits [19:0] are assumed to be FFFFh.

14.1.19 PREFETCHABLE MEMORY BASE REGISTER – OFFSET 24h

Bit	Function	Type	Description
3:0	64-bit addressing	R/O	Indicates 64-bit addressing 0000: 32-bit addressing 0001: 64-bit addressing Reset to 1
15:4	Prefetchable Memory Base Address [31:20]	R/W	Defines the bottom address of an address range for the bridge to determine when to forward memory read and write transactions from one interface to the other. The upper 12 bits correspond to address bits [31:20] and are writable. The lower 20 bits are assumed to be 0.

14.1.20 PREFETCHABLE MEMORY LIMIT REGISTER – OFFSET 24h

Bit	Function	Type	Description
19:16	64-bit addressing	R/O	Indicates 64-bit addressing 0000: 32-bit addressing 0001: 64-bit addressing Reset to 1
31:20	Prefetchable Memory Base Address [31:20]	R/W	Defines the top address of an address range for the bridge to determine when to forward memory read and write transactions from one interface to the other. The upper 12 bits correspond to address bits [31:20] and are writable. The lower 20 bits are assumed to be FFFFh.

14.1.21 PREFETCHABLE MEMORY BASE ADDRESS UPPER 32-BITS REGISTER – OFFSET 28h

Bit	Function	Type	Description
31:0	Prefetchable Memory Base Address, Upper 32-bits [63:32]	R/W	Defines the upper 32-bits of a 64-bit bottom address of an address range for the bridge to determine when to forward memory read and write transactions from one interface to the other. Reset to 0

14.1.22 PREFETCHABLE MEMORY LIMIT ADDRESS UPPER 32-BITS REGISTER – OFFSET 2Ch

Bit	Function	Type	Description
31:0	Prefetchable Memory Limit Address, Upper 32-bits [63:32]	R/W	Defines the upper 32-bits of a 64-bit top address of an address range for the bridge to determine when to forward memory read and write transactions from one interface to the other. Reset to 0

14.1.23 I/O BASE ADDRESS UPPER 16-BITS REGISTER – Offset 30h

Bit	Function	Type	Description
15:0	I/O Base Address, Upper 16-bits [31:16]	R/W	Defines the upper 16-bits of a 32-bit bottom address of an address range for the bridge to determine when to forward I/O transactions from one interface to the other. Reset to 0

14.1.24 I/O LIMIT ADDRESS UPPER 16-BITS REGISTER – OFFSET 30h

Bit	Function	Type	Description
31:0	I/O Limit Address, Upper 16-bits [31:16]	R/W	Defines the upper 16-bits of a 32-bit top address of an address range for the bridge to determine when to forward I/O transactions from one interface to the other. Reset to 0

14.1.25 ECP POINTER REGISTER – OFFSET 34h

Bit	Function	Type	Description
7:0	Enhanced Capabilities Port Pointer	R/O	Enhanced capabilities port offset pointer. Read as B0h to indicate that the first item resides at that configuration offset.

14.1.26 BRIDGE CONTROL REGISTER – OFFSET 3Ch

Bit	Function	Type	Description
16	Parity Error Response	R/W	Controls the bridge's response to parity errors on the secondary interface. 0: ignore address and data parity errors on the secondary interface 1: enable parity error reporting and detection on the secondary interface Reset to 0
17	S1_SERR# enable	R/W	Controls the forwarding of S1_SERR# or S2_SERR# to the primary interface. 0: disable the forwarding of S1_SERR# or S2_SERR# to primary interface 1: enable the forwarding of S1_SERR# or S2_SERR# to primary interface Reset to 0

Bit	Function	Type	Description
18	ISA enable	R/W	<p>Modifies the bridge's response to ISA I/O addresses, applying only to those addresses falling within the I/O base and limit address registers and within the first 64KB or PCI I/O space.</p> <p>0: forward all I/O addresses in the range defined by the I/O base and I/O limit registers</p> <p>1: blocks forwarding of ISA I/O addresses in the range defined by the I/O base and I/O limit registers that are in the first 64KB of I/O space that address the last 768 bytes in each 1KB block. Secondary I/O transactions are forwarded upstream if the address falls within the last 768 bytes in each 1KB block</p> <p>Reset to 0</p>
19	VGA enable	R/W	<p>Controls the bridge's response to VGA compatible addresses.</p> <p>0: does not forward VGA compatible memory and I/O addresses from primary to secondary</p> <p>1: forward VGA compatible memory and I/O addresses from primary to secondary regardless of other settings</p> <p>Reset to 0</p>
20	Reserved	R/O	Reserved. Returns 0 when read. Reset to 0
21	Master Abort Mode	R/W	<p>Control's bridge's behavior responding to master aborts on secondary interface.</p> <p>0: does not report master aborts (returns FFFF_FFFFh on reads and discards data on writes)</p> <p>1: reports master aborts by signaling target abort if possible by the assertion of P_SERR# if enabled</p> <p>Reset to 0</p>
22	Secondary Interface Reset	R/W	<p>Controls the assertion of S1_RESET# or S2_RESET# signal pin on the secondary interface</p> <p>0: does not force the assertion of S1_RESET# or S2_RESET# pin</p> <p>1: forces the assertion of S1_RESET# or S2_RESET#</p> <p>Reset to 0</p>
23	Fast Back-to-Back Enable	R/W	<p>Controls bridge's ability to generate fast back-to-back transactions to different devices on the secondary interface.</p> <p>0: does not allow fast back-to-back transactions</p> <p>1: enables fast back-to-back transactions</p> <p>Reset to 0</p>
24	Reserved	R/W	Reserved. Reset to 0
25	Reserved	R/W	Reserved. Reset to 0
26	Master Timeout Status	R/WC	<p>This bit is set to 1 when either the primary master timeout counter or secondary master timeout counter expires.</p> <p>Reset to 0</p>
27	Discard Timer P_SERR# enable	R/WC	<p>This bit is set to 1 and P_SERR# is asserted when either the primary discard timer or the secondary S1 or S2 discard timer expire.</p> <p>Reset to 0</p>
31-28	Reserved	R/O	Reserved. Returns 0 when read. Reset to 0.

14.1.27 DIAGNOSTIC / CHIP CONTROL REGISTER – OFFSET 40h

Configuration 1

Bit	Function	Type	Description
0	Reserved	R/O	Reserved. Returns 0 when read. Reset to 0
1	Memory Write Disconnect Control	R/W	Controls when the bridge (as a target) disconnects memory write transactions. 0: memory write disconnects at 4KB aligned address boundary 1: memory write disconnects at cache line aligned address boundary Reset to 0
3:2	Reserved	R/O	Reserved. Returns 0 when read. Reset to 0.
4	Memory Read Flow-Through Control	R/W	Controls whether the bridge supports memory read flow-through 0: Enable 1: Disable Reset to 0
8:5	Reserved	R/O	Reserved. Returns 0 when read. Reset to 0
10:9	Test Mode For All Counters at P and S1	R/O	Controls the testability of the bridge's internal counters. The bits are used for chip test only. 00: all bits are exercised 01: byte 1 is exercised 10: byte 2 is exercised 11: byte 3 is exercised Reset to 0
15:11	Reserved	R/O	Reserved. Returns 0 when read. Reset to 0.

Configuration 2

Bit	Function	Type	Description
0	Reserved	R/O	Reserved. Returns 0 when read. Reset to 0
1	Memory Write Disconnect Control at S2	R/W	Controls when the bridge (as a target) disconnects memory write transactions. 0: memory write disconnects at 4KB aligned address boundary 1: memory write disconnects at cache line aligned address boundary Reset to 0
3:2	Reserved	R/O	Reserved. Returns 0 when read. Reset to 0
4	Memory Read Flow-through Control	R/W	Controls whether the bridge supports memory read flow-through 0: Enable 1: Disable Reset to 0
8:5	Reserved	R/O	Reserved. Returns 0 when read. Reset to 0
10:9	Test Mode For All Counters at S2	R/O	Controls the testability of the bridge's internal counters. The bits are used for chip test only. 00: all bits are exercised 01: byte 1 is exercised 10: byte 2 is exercised 11: byte 3 is exercised Reset to 0
15:11	Reserved	R/O	Reserved. Returns 0 when read. Reset to 0.

14.1.28 ARBITER CONTROL REGISTER – OFFSET 40h

Bit	Function	Type	Description
23:16	Arbiter Control	R/W	Each bit controls whether a secondary bus master is assigned to the high priority group or the low priority group. Bits [23:16] correspond to request inputs S1_REQ[7:0] or S2_REQ[6:0] 0: low priority 1: high priority Reset to 0
24	Reserved	R/O	Reserved. Returns 0 when read. Reset to 0
25	Priority of Secondary Interface	R/W	Controls whether the S1 or S2 interface of the bridge is in the high priority group or the low priority group. 0: low priority 1: high priority Reset to 1
26	Arbiter Park Function	R/W	Controls the arbiter's park function. 0: park to last master 1: park to bridge port S1 or S2 Reset to 0
31:27	Reserved	R/O	Reserved. Returns 0 when read. Reset to 0.

14.1.29 UPSTREAM MEMORY CONTROL REGISTER – OFFSET 48h

Bit	Function	Type	Description
16	Upstream (S1 or S2 to P) Memory Base and Limit Enable	R/W	0: Upstream memory is the entire range except the down stream memory channel 1: Upstream memory is confined to upstream Memory Base and Limit (See offset 50 th and 54 th for upstream memory range) Reset to 0
17	Upstream (S1 or S2 to P) Memory Prefetchable Enable	R/W	0: Upstream memory is prefetchable at Primary 1: Upstream memory is not prefetchable at Primary Reset to 0
31:18	Reserved	R/O	Reserved. Returns 0 when read. Reset to 0

14.1.30 HOT SWAP SWITCH TIME SLOT REGISTER – OFFSET 4Ch

Bit	Function	Type	Description
27:0	Hot Swap Time Slot	R/W	Hot Swap time slot (15K PCI clocks) Reset to 0003A98h

Bit	Function	Type	Description
30:28	Secondary Bus Master Preemption Control	R/W	Sets the number of clocks for time-to-preempt after another master request. 000: 32 clocks 001: 8 clocks 010: 16 clocks 011: 64 clocks 100: 128 clocks Reset to 000
31	Preemption	R/W	Sets preemption. 0: preemption ON 1: preemption OFF Reset to 0

14.1.31 UPSTREAM (S1 or S2 to P) MEMORY BASE REGISTER – OFFSET 50h

Bit	Function	Type	Description
3:0	64 bit addressing	R/O	0: 32 bit addressing 1: 64 bit addressing Reset to 1
15:4	Upstream Memory Base Address	R/W	Controls upstream memory base address. Reset to 00000000h

14.1.32 UPSTREAM (S1 or S2 to P) MEMORY LIMIT REGISTER – OFFSET 50h

Bit	Function	Type	Description
19:16	64 bit addressing	R/O	0: 32 bit addressing 1: 64 bit addressing Reset to 1
31:20	Upstream Memory Limit Address	R/W	Controls upstream memory limit address. Reset to 000FFFFh

14.1.33 UPSTREAM (S1 or S2 to P) MEMORY BASE UPPER 32-BITS REGISTER – OFFSET 54h

Bit	Function	Type	Description
31:0	Upstream Memory Base Address	R/W	Defines bits [63:32] of the upstream memory base Reset to 0

14.1.34 UPSTREAM (S1 or S2 to P) MEMORY LIMIT UPPER 32 BITS REGISTER – OFFSET 58h

Bit	Function	Type	Description
31:0	Upstream Memory Limit Address	R/W	Defines bits [63:32] of the upstream memory limit Reset to 0

14.1.35 P_SERR# EVENT DISABLE REGISTER – OFFSET 64h

Bit	Function	Type	Description
0	Reserved	R/O	Reserved. Returns 0 when read. Reset to 0
1	Posted Write Parity Error	R/W	Controls PI7C7300D's ability to assert P_SERR# when it is unable to transfer any read data from the target after 2 ²⁴ attempts. 0: P_SERR# is asserted if this event occurs and the SERR# enable bit in the command register is set. 1: P_SERR# is not assert if this event occurs. Reset to 0
2	Posted Write Non-Delivery	R/W	Controls PI7C7300D's ability to assert P_SERR# when it is unable to transfer delayed write data after 2 ²⁴ attempts. 0: P_SERR# is asserted if this event occurs and the SERR# enable bit in the command register is set 1: P_SERR# is not asserted if this event occurs Reset to 0
3	Target Abort During Posted Write	R/W	Controls PI7C7300D's ability to assert P_SERR# when it receives a target abort when attempting to deliver posted write data. 0: P_SERR# is asserted if this event occurs and the SERR# enable bit in the command register is set 1: P_SERR# is not asserted if this event occurs Reset to 0
4	Master Abort On Posted Write	R/W	Controls PI7C7300D's ability to assert P_SERR# when it receives a master abort when attempting to deliver posted write data. 0: P_SERR# is asserted if this event occurs and the SERR# enable bit in the command register is set 1: P_SERR# is not asserted if this event occurs Reset to 0
5	Delayed Write Non-Delivery	R/W	Controls PI7C7300D's ability to assert P_SERR# when it is unable to transfer delayed write data after 2 ²⁴ attempts. 0: P_SERR# is asserted if this event occurs and the SERR# enable bit in the command register is set 1: P_SERR# is not asserted if this event occurs Reset to 0

Bit	Function	Type	Description
6	Delayed Read – No Data From Target	R/W	Controls PI7C7300D's ability to assert P_SERR# when it is unable to transfer any read data from the target after 2 ²⁴ attempts. 0: P_SERR# is asserted if this event occurs and the SERR# enable bit in the command register is set 1: P_SERR# is not asserted if this event occurs Reset to 0
7	Reserved	R/O	Reserved. Returns 0 when read. Reset to 0

14.1.36 SECONDARY CLOCK CONTROL REGISTER – OFFSET 68h

Configuration Register 1

Bit	Function	Type	Description
1:0	Clock 0 disable	R/W	If either bit is 0, then S1_CLKOUT [0] is enabled. If both bits are 1, the S1_CLKOUT [0] is disabled.
3:2	Clock 1 disable	R/W	If either bit is 0, then S1_CLKOUT [1] is enabled. If both bits are 1, the S1_CLKOUT [1] is disabled.
5:4	Clock 2 disable	R/W	If either bit is 0, then S1_CLKOUT [2] is enabled. If both bits are 1, the S1_CLKOUT [2] is disabled.
7:6	Clock 3 disable	R/W	If either bit is 0, then S1_CLKOUT [3] is enabled. If both bits are 1, the S1_CLKOUT [3] is disabled.
9:8	Clock 4 disable	R/W	If either bit is 0, then S1_CLKOUT [4] is enabled. If both bits are 1, the S1_CLKOUT [4] is disabled.
11:10	Clock 5 disable	R/W	If either bit is 0, then S1_CLKOUT [5] is enabled. If both bits are 1, the S1_CLKOUT [5] is disabled.
13:12	Clock 6 disable	R/W	If either bit is 0, then S1_CLKOUT [6] is enabled. If both bits are 1, the S1_CLKOUT [6] is disabled.
15:14	Clock 7 disable	R/W	If either bit is 0, then S1_CLKOUT [7] is enabled. If both bits are 1, the S1_CLKOUT [7] is disabled.

Configuration Register 2

Bit	Function	Type	Description
1:0	Clock 0 disable	R/W	If either bit is 0, then S2_CLKOUT [0] is enabled. If both bits are 1, the S2_CLKOUT [0] is disabled.
3:2	Clock 1 disable	R/W	If either bit is 0, then S2_CLKOUT [1] is enabled. If both bits are 1, the S2_CLKOUT [1] is disabled.
5:4	Clock 2 disable	R/W	If either bit is 0, then S2_CLKOUT [2] is enabled. If both bits are 1, the S2_CLKOUT [2] is disabled.
7:6	Clock 3 disable	R/W	If either bit is 0, then S2_CLKOUT [3] is enabled. If both bits are 1, the S2_CLKOUT [3] is disabled.
9:8	Clock 4 disable	R/W	If either bit is 0, then S2_CLKOUT [4] is enabled. If both bits are 1, the S2_CLKOUT [4] is disabled.
11:10	Clock 5 disable	R/W	If either bit is 0, then S2_CLKOUT [5] is enabled. If both bits are 1, the S2_CLKOUT [5] is disabled.
13:12	Clock 6 disable	R/W	If either bit is 0, then S2_CLKOUT [6] is enabled. If both bits are 1, the S2_CLKOUT [6] is disabled.
15:14	Clock 7 disable	R/W	If either bit is 0, then S2_CLKOUT [7] is enabled. If both bits are 1, the S2_CLKOUT [7] is disabled.

14.1.37 PORT OPTION REGISTER – OFFSET 74h

Bit	Function	Type	Description
0	Reserved	R/O	Reserved. Returns 0 when read. Reset to 0.

Bit	Function	Type	Description
1	Primary MEMR Command Alias Enable	R/W	Controls PI7C7300D's detection mechanism for matching memory read retry cycles from the initiator on the primary interface 0: exact matching for non-posted memory write retry cycles from initiator on the primary interface 1: alias MEMRL or MEMRM to MEMR for memory read retry cycles from the initiator on the primary interface Reset to 0
2	Primary MEMW Command Alias Enable	R/W	Controls PI7C7300D's detection mechanism for matching non-posted memory write retry cycles from the initiator on the primary interface 0: exact matching for non-posted memory write retry cycles from initiator on the primary interface 1: alias MEMWI to MEMW for non-posted memory write retry cycles from initiator on the primary interface Reset to 0
3	Secondary MEMR Command Alias Enable	R/W	Controls PI7C7300D's detection mechanism for matching memory read retry cycles from the initiator on S1 0: exact matching for memory read retry cycles from initiator on the S1 or S2 interface 1: alias MEMRL or MEMRM to MEMR for memory read retry cycles from initiator on the S1 or S2 interface Reset to 0
4	Secondary MEMW Command Alias Enable	R/W	Controls PI7C7300D's detection mechanism for matching non-posted memory write retry cycles from the initiator on the primary interface 0: exact matching for non-posted memory write retry cycles from initiator on the S1 or S2 interface 1: alias MEMWI to MEMW for non-posted memory write retry cycles from initiator on the S1 or S2 interface Reset to 0
8:5	Reserved	R/O	Reserved. Returns 0 when read. Reset to 0.
9	Enable Long Request	R/W	Controls PI7C7300D's ability to enable long requests for lock cycles 0: normal lock operation 1: enable long request for lock cycle Reset to 0
10	Enable Secondary To Hold Request Longer	R/W	Control's PI7C7300D's ability to enable S1 or S2 to hold requests longer. 0: internal S1 or S2 master will release REQ# after FRAME# assertion 1: internal S1 or S2 master will hold REQ# until there is no transactions pending in FIFO or until terminated by target Reset to 0
11	Enable Primary To Hold Request Longer	R/W	Control's PI7C7300D's ability to hold requests longer at the Primary Port. 0: internal Primary master will release REQ# after FRAME# assertion 1: internal Primary master will hold REQ# until there is no transactions pending in FIFO or until terminated by target Reset to 0
15:12	Reserved	R/O	Reserved. Returns 0 when read. Reset to 0.

14.1.38 MASTER TIMEOUT COUNTER REGISTER – OFFSET 74h

Bit	Function	Type	Description
31:16	Master Timeout	R/W	Holds the maximum number of PCI clocks that PI7C7300D will wait for initiator to retry the same cycle before reporting timeout. Master timeout occurs after 2 ¹⁰ PCI clocks. Default is 400h.

14.1.39 RETRY COUNTER REGISTER – OFFSET 78h

Bit	Function	Type	Description
31:0	Retry Counter	R/W	Holds the maximum number of attempts that PI7C7300D will try before reporting retry timeout. Retry count set at 2 ²⁴ PCI clocks. Default is 0100 0000h.

14.1.40 SAMPLING TIMER REGISTER – OFFSET 7Ch

Bit	Function	Type	Description
31:0	Sampling Timer	R/W	Sets the duration (in PCI clocks) during which PI7C7300D will record the number of successful transactions for performance evaluation. The recording will start right after this register is programmed and will be cleared after the timer expires. Maximum period is 128 seconds at 33MHz. Reset to 0.

14.1.41 SECONDARY SUCCESSFUL I/O READ COUNTER REGISTER – OFFSET 80h

Bit	Function	Type	Description
31:0	Successful I/O Read Counts on S1 or S2	R/W	Stores the successful I/O read count on S1 or S2 and is updated when the sampling timer is active. Reset to 0

14.1.42 SECONDARY SUCCESSFUL I/O WRITE COUNTER REGISTER – OFFSET 84h

Bit	Function	Type	Description
31:0	Successful I/O Write Counts on S1 or S2	R/W	Stores the successful I/O write count on S1 or S2 and is updated when the sampling timer is active. Reset to 0

14.1.43 SECONDARY SUCCESSFUL MEMORY READ COUNTER REGISTER – Offset 88h

Bit	Function	Type	Description
31:0	Successful Memory Read Counts on S1 or S2	R/W	Stores the successful memory read count on S1 or S2 and is updated when the sampling timer is active. Reset to 0

14.1.44 SECONDARY SUCCESSFUL MEMORY WRITE COUNTER REGISTER – OFFSET 8Ch

Bit	Function	Type	Description
31:0	Successful Memory Write Counts on S1 or S2	R/W	Stores the successful memory write count on S1 or S2 and is updated when the sampling timer is active. Reset to 0

14.1.45 PRIMARY SUCCESSFUL I/O READ COUNTER REGISTER – OFFSET 90h

Bit	Function	Type	Description
31:0	Successful I/O Read Counts on Primary	R/W	Stores the successful I/O read count on Primary and is updated when the sampling timer is active. Reset to 0

14.1.46 PRIMARY SUCCESSFUL I/O WRITE COUNTER REGISTER – OFFSET 94h

Bit	Function	Type	Description
31:0	Successful I/O Write Counts on Primary	R/W	Stores the successful I/O write count on Primary and is updated when the sampling timer is active. Reset to 0

14.1.47 PRIMARY SUCCESSFUL MEMORY READ COUNTER REGISTER – OFFSET 98h

Bit	Function	Type	Description
31:0	Successful Memory Read Counts on Primary	R/W	Stores the successful memory read count on Primary and is updated when the sampling timer is active. Reset to 0

14.1.48 PRIMARY SUCCESSFUL MEMORY WRITE COUNTER REGISTER – OFFSET 9Ch

Bit	Function	Type	Description
31:0	Successful Memory Write Counts on Primary	R/W	Stores the successful memory write count on Primary and is updated when the sampling timer is active. Reset to 0

14.1.49 CAPABILITY ID REGISTER – OFFSET B0h

Bit	Function	Type	Description
7:0	Capability ID	R/O	Capability ID for slot identification 00h: Reserved 01h: PCI Power Management (PCIPM) 02h: Accelerated Graphics Port (AGP) 03h: Vital Product Data (VPD) 04h: Slot Identification (SI) 05h: Message Signaled Interrupts (MSI) 06h: Compact PCI Hot Swap (CHS) 07h – 255h: Reserved Reset to 04h

14.1.50 NEXT POINTER REGISTER – OFFSET B0h

Bit	Function	Type	Description
15:8	Next Pointer	R/O	Reset to 1100 0000: next pointer (C0h if HS_EN is 1) 0000 0000: next pointer (00h if HS_EN is 0)

14.1.51 SLOT NUMBER REGISTER – OFFSET B0h

Bit	Function	Type	Description
20:16	Expansion Slot Number	R/W	Determines expansion slot number Reset to 0
21	First in Chassis	R/W	First in chassis Reset to 0
23:22	Reserved	R/O	Reserved. Returns 0 when read. Reset to 0.

14.1.52 CHASSIS NUMBER REGISTER – OFFSET B0h

Bit	Function	Type	Description
31:24	Chassis Number Register	R/W	Chassis number register. Reset to 0

14.1.53 CAPABILITY ID REGISTER – OFFSET C0h

Bit	Function	Type	Description
7:0	Capability ID for Hot Swap	R/O	Capability ID for Hot Swap 00h: Reserved 01h: PCI Power Management (PCIPM) 02h: Accelerated Graphics Port (AGP) 03h: Vital Product Data (VPD) 04h: Slot Identification (SI) 05h: Message Signaled Interrupts (MSI) 06h: Compact PCI Hot Swap (CHS) 07h – 255h: Reserved Reset to 06h

14.1.54 NEXT POINTER REGISTER – OFFSET C0h

Bit	Function	Type	Description
15:8	Next Pointer	R/O	00: End of pointer (00h).

14.1.55 HOT SWAP CONTROL AND STATUS REGISTER – OFFSET C0h

Bit	Function	Type	Description
16	Not Available	R/O	Not used. Returns 0 when read. Reset to 0
17	ENUM Signal Mask	R/W	0: Mask ENUM# signal 1: Enable ENUM# signal
18	Not Available	R/O	Not used. Returns 0 when read. Reset to 0
19	LED ON/OFF	R/W	LOO signal (LED on/off) 0: LED on 1: LED off Reset to 0
21:20	Not Available	R/O	Not Used. Returns 0 when read. Reset to 0
22	ENUM# Status – Extraction	R/W	0: ENUM# asserted 1: ENUM# not asserted Reset to 0
23	ENUM# Status – Insertion	R/W	0: ENUM# asserted 1: ENUM# not asserted Reset to 0
31:24	Reserved	R/O	Reserved. Returns 0 when read. Reset to 0

15 BRIDGE BEHAVIOR

A PCI cycle is initiated by asserting the FRAME# signal. In a bridge, there are a number of possibilities. Those possibilities are summarized in the table below:

15.1 BRIDGE ACTIONS FOR VARIOUS CYCLE TYPES

Initiator	Target	Response
Master on Primary	Target on Primary	PI7C7300D does not respond. It detects this situation by decoding the address as well as monitoring the P_DEVSEL# for other fast and medium devices on the Primary Port.
Master on Primary	Target on Secondary	PI7C7300D asserts P_DEVSEL#, terminates the cycle normally if it is able to be posted, otherwise return with a retry. It then passes the cycle to the appropriate port. When the cycle is complete on the target port, it will wait for the initiator to repeat the same cycle and end with normal termination.
Master on Primary	Target not on Primary nor Secondary Port	PI7C7300D does not respond and the cycle will terminate as master abort.
Master on Secondary	Target on the same Secondary Port	PI7C7300D does not respond.
Master on Secondary	Target on Primary or the other Secondary Port	PI7C7300D asserts S1_DEVSEL# or S2_DEVSEL#, terminates the cycle normally if it is able to be posted, otherwise returns with a retry. It then passes the cycle to the appropriate port. When cycle is complete on the target port, it will wait for the initiator to repeat the same cycle and end with normal termination.
Master on Secondary	Target not on Primary nor the other Secondary Port	PI7C7300D does not respond.

15.2 TRANSACTION ORDERING

To maintain data coherency and consistency, PI7C7300D complies with the ordering rules put forth in the *PCI Local Bus Specification, Rev 2.2*. The following table summarizes the ordering relationship of all the transactions through the bridge.

PMW - Posted write (either memory write or memory write & invalidate)

DRR - Delayed read request (all memory read, I/O read & configuration read)

DWR - Delayed write request (I/O write & configuration write, memory write to certain location)

DRC - Delayed read completion (all memory read, I/O read & configuration read)

DWC - Delayed write completion (I/O write & configuration write, memory write to certain location)

Cycle type shown on each row is the subsequent cycle after the previous shown on the column.

Can Row Pass Column?	PMW Column 1	DRR Column 2	DWR Column 3	DRC Column 4	DWC Column 5
PMW (Row 1)	No	Yes	Yes	Yes	Yes
DRR (Row 2)	No	No	No	Yes	Yes
DWR (Row 3)	No	No	No	Yes	Yes
DRC (Row 4)	No	Yes	Yes	No	No

DWC (Row 5)	Yes	Yes	Yes	No	No
-------------	-----	-----	-----	----	----

In Row 1 Column 1, PMW cannot pass the previous PMW and that means they must complete on the target bus in the order in which they were received in the initiator bus.

In Row 2 Column1, DRR cannot pass the previous PMW and that means the previous PMW heading to the same direction must be completed before the DRR can be attempted on the target bus.

In Row 1 Column 2, PMW can pass the previous DRR as long as the DRR reaches the head of the delayed transaction queue.

15.3 ABNORMAL TERMINATION (INITIATED BY BRIDGE MASTER)

15.3.1 MASTER ABORT

Master abort indicates that when PI7C7300D acts as a master and receives no response (i.e., no target asserts DEVSEL# or S1_DEVSEL# or S2_DEVSEL#) from a target, the bridge deasserts FRAME# and then deasserts IRDY#.

15.3.2 PARITY AND ERROR REPORTING

Parity must be checked for all addresses and write data. Parity is defined on the P_PAR, S1_PAR, and S2_PAR signals. Parity should be even (i. e. an even number of '1's) across AD, CBE, and PAR. Parity information on PAR is valid the cycle after AD and CBE are valid. For reads, even parity must be generated using the initiators CBE signals combined with the read data. Again, the PAR signal corresponds to read data from the previous data phase cycle.

15.3.3 REPORTING PARITY ERRORS

For all address phases, if a parity error is detected, the error should be reported on the P_SERR# signal by asserting P_SERR# for one cycle and then 3-stating two cycles after the bad address. P_SERR# can only be asserted if bit 6 and 8 in the Command Register are both set to 1. For write data phases, a parity error should be reported by asserting the P_PERR# signal two cycles after the data phase and should remain asserted for one cycle when bit 6 in the Command register is set to a 1. The target reports any type of data parity errors during write cycles, while the master reports data parity errors during read cycles.

Detection of an address parity error will cause the PCI-to-PCI Bridge target to not claim the bus (P_DEVSEL# remains inactive) and the cycle will then terminate with a Master Abort. When the bridge is acting as master, a data parity error during a read cycle results in the bridge master initiating a Master Abort.

15.3.4 SECONDARY IDSEL MAPPING

When PI7C7300D detects a Type 1 configuration transaction for a device connected to the secondary, it translates the Type 1 transaction to Type 0 transaction on the downstream interface. Type 1 configuration format uses a 5-bit field at P_AD[15:11] as a device number. This is translated to S1_AD[31:16] or S2_AD[31:16] by PI7C7300D.

16 IEEE 1149.1 COMPATIBLE JTAG CONTROLLER

An IEEE 1149.1 compatible Test Access Port (TAP) controller and associated TAP pins are provided to support boundary scan in PI7C7300D for board-level continuity test and diagnostics. The TAP pins assigned are TCK, TDI, TDO, TMS and TRST#. All digital input, output, input/output pins are tested except TAP pins and clock pin.

The IEEE 1149.1 Test Logic consists of a TAP controller, an instruction register, and a group of test data registers including Bypass, Device Identification and Boundary Scan registers. The TAP controller is a synchronous 16-state machine driven by the Test Clock (TCK) and the Test Mode Select (TMS) pins. An independent power on reset circuit is provided to ensure the machine is in TEST_LOGIC_RESET state at power-up. The JTAG signal lines are not active when the PCI resource is operating PCI bus cycles.

PI7C7300D implements 3 basic instructions: BYPASS, SAMPLE/PRELOAD, and EXTEST.

16.1 BOUNDARY SCAN ARCHITECTURE

Boundary-scan test logic consists of a boundary-scan register and support logic. These are accessed through a Test Access Port (TAP). The TAP provides a simple serial interface that allows all processor signal pins to be driven and/or sampled, thereby providing direct control and monitoring of processor pins at the system level.

This mode of operation is valuable for design debugging and fault diagnosis since it permits examination of connections not normally accessible to the test system. The following subsections describe the boundary-scan test logic elements: TAP pins, instruction register, test data registers and TAP controller. **Error! Reference source not found.** illustrates how these pieces fit together to form the JTAG unit.

Figure 16-1 TEST ACCESS PORT BLOCK DIAGRAM

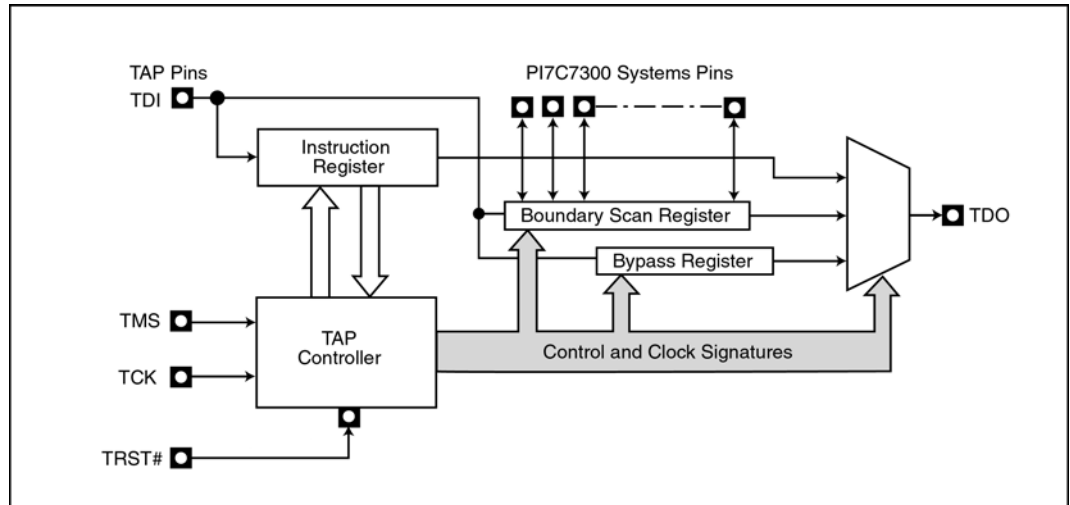

16.1.1 TAP PINS

The PI7C7300D's TAP pins form a serial port composed of four input connections (TMS, TCK, TRST# and TDI) and one output connection (TDO). These pins are described in Table 16-1. The TAP pins provide access to the instruction register and the test data registers.

16.1.2 INSTRUCTION REGISTER

The Instruction Register (IR) holds instruction codes. These codes are shifted in through the Test Data Input (TDI) pin. The instruction codes are used to select the specific test operation to be performed and the test data register to be accessed.

The instruction register is a parallel-loadable, master/slave-configured 4-bit wide, serial-shift register with latched outputs. Data is shifted into and out of the IR serially through the TDI pin clocked by the rising edge of TCK. The shifted-in instruction becomes active upon latching from the master stage to the slave stage. At that time the IR outputs along with the TAP finite state machine outputs are decoded to select and control the test data register selected by that instruction. Upon latching, all actions caused by any previous instructions terminate.

The instruction determines the test to be performed, the test data register to be accessed, or both. The IR is two bits wide. When the IR is selected, the most significant bit is connected to TDI, and the least significant bit is connected to TDO. The value presented on the TDI pin is shifted into the IR on each rising edge of TCK. The TAP controller captures fixed parallel data (1101 binary). When a new instruction is shifted in through TDI, the value 1101(binary) is always shifted out through TDO, least significant bit first. This helps identify instructions in a long chain of serial data from several devices.

Upon activation of the TRST# reset pin, the latched instruction asynchronously changes to the id code instruction. When the TAP controller moves into the test state other than by reset activation, the opcode changes as TDI shifts, and becomes active on the falling edge of TCK.

16.2 BOUNDARY-SCAN INSTRUCTION SET

The PI7C7300D supports three mandatory boundary-scan instructions (bypass, sample/preload and extest). The table shown below lists the PI7C7300D's boundary-scan instruction codes. The "reserved" code should not be used.

Instruction Code (binary)	Instruction Name	Instruction Code (binary)	Instruction Name
0000	EXTEST	0101	Reserved
0001	SAMPLE/PRELOAD	1111	Bypass

Table 16-1 TAP PINS

Instruction Requisite /	Opcode (binary)	Description
Extest IEEE 1149.1 Required	0000	Extest initiates testing of external circuitry, typically board-level interconnects and off chip circuitry. Extest connects the boundary-scan register between TDI and TDO. When Extest is selected, all output signal pin values are driven by values shifted into the boundary-scan register and may change only of the falling edge of TCK. Also, when extest is selected, all system input pin states must be loaded into the boundary-scan register on the rising-edge of TCK.
Sample/preload IEEE 1149.1 Required	0001	Sample/preload performs two functions: 1. A snapshot of the sample instruction is captured on the rising edge of TCK without interfering with normal operation. The instruction causes boundary-scan register cells associated with outputs to sample the value being driven. 2. On the falling edge of TCK, the data held in the boundary-scan cells is transferred to the slave register cells. Typically, the slave latched data is applied to the system outputs via the extest instruction.
Idcode IEEE 1149.1 Required	0101	Reserved
Bypass IEEE 1149.1 Required	1111	Bypass instruction selects the one-bit bypass register between TDI and TDO pins. 0 (binary) is the only instruction that accesses the bypass register. While this instruction is in effect, all other test data registers have no effect on system operation. Test data registers with both test and system functionality perform their system functions when this instruction is selected.

16.3 TAP TEST DATA REGISTERS

The PI7C7300D contains two test data registers (bypass and boundary-scan). Each test data register selected by the TAP controller is connected serially between TDI and TDO. TDI is connected to the test data register's most significant bit. TDO is connected to the least significant bit. Data is shifted one bit position within the register towards TDO on

each rising edge of TCK. While any register is selected, data is transferred from TDI to TDO without inversion. The following sections describe each of the test data registers.

16.4 BYPASS REGISTER

The required bypass register, a one-bit shift register, provides the shortest path between TDI and TDO when a bypass instruction is in effect. This allows rapid movement of test data to and from other components on the board. This path can be selected when no test operation is being performed on the PI7C7300D.

16.5 BOUNDARY-SCAN REGISTER

The boundary-scan register contains a cell for each pin as well as control cells for I/O and the high-impedance pin.

Table 16-2 shows the bit order of the PI7C7300D boundary-scan register. All table cells that contain “Control” select the direction of bi-directional pins or high-impedance output pins. When a “0” is loaded into the control cell, the associated pin(s) are high-impedance or selected as input.

The boundary-scan register is a required set of serial-shiftable register cells, configured in master/slave stages and connected between each of the PI7C7300D’s pins and on-chip system logic. The VDD, GND, PLL, AGND, AVDD and JTAG pins are NOT in the boundary-scan chain.

The boundary-scan register cells are dedicated logic and do not have any system function. Data may be loaded into the boundary-scan register master cells from the device input pins and output pin-drivers in parallel by the mandatory sample/preload and extest instructions. Parallel loading takes place on the rising edge of TCK.

Data may be scanned into the boundary-scan register serially via the TDI serial input pin, clocked by the rising edge of TCK. When the required data has been loaded into the master-cell stages, it can be driven into the system logic at input pins or onto the output pins on the falling edge of TCK state. Data may also be shifted out of the boundary-scan register by means of the TDO serial output pin at the falling edge of TCK.

16.6 TAP CONTROLLER

The TAP (Test Access Port) controller is a 4-state synchronous finite state machine that controls the sequence of test logic operations. The TAP can be controlled via a bus master. The bus master can be either automatic test equipment or a component (i.e., PLD) that interfaces to the TAP. The TAP controller changes state only in response to a rising edge of TCK. The value of the test mode state (TMS) input signal at a rising edge of TCK controls the sequence of state changes. The TAP controller is initialized after power-up by applying a low to the TRST# pin. In addition, the TAP controller can be initialized by applying a high signal level on the TMS input for a minimum of five TCK periods.

For greater detail on the behavior of the TAP controller, test logic in each controller state and the state machine and public instructions, refer to the IEEE 1149.1 Standard Test Access Port and Boundary-Scan Architecture document (available from the IEEE).

Table 16-2 JTAG BOUNDARY REGISTER ORDER

Order	Pin Names	Type
0	ENUM#	output
1	ENUM#	control
2	HS_EN	input
3	S_CFN#	input
4	S1_EN	input
5	S2_EN	input
6	SCAN_TM#	input
7	SCAN_EN	input
8	PLL_TM	input
9	BY_PASS	input
10	S2_M66EN	input
11	P_RESET#	input
12	P_GNT#	input
13	P_REQ#	output
14	P_REQ#	control
15	P_AD[30]	bidir
16	P_AD[30]	control
17	P_AD[31]	bidir
18	P_AD[31]	control
19	P_AD[27]	bidir
20	P_AD[27]	control
21	P_AD[26]	bidir
22	P_AD[26]	control
23	P_AD[28]	bidir
24	P_AD[28]	control
25	P_AD[29]	bidir
26	P_AD[29]	control
27	P_CBE[3]	bidir
28	P_CBE[3]	control
29	P_AD[24]	bidir
30	P_AD[24]	control
31	P_AD[25]	bidir
32	P_AD[25]	control
33	P_AD[23]	bidir
34	P_AD[23]	control
35	P_AD[22]	bidir
36	P_AD[22]	control
37	P_IDSEL	input
38	P_AD[21]	bidir
39	P_AD[21]	control
40	P_AD[20]	bidir
41	P_AD[20]	control
42	P_AD[19]	bidir
43	P_AD[19]	control
44	P_AD[18]	bidir
45	P_AD[18]	control
46	P_AD[17]	bidir
47	P_AD[17]	control
48	P_AD[16]	bidir
49	P_AD[16]	control
50	P_CBE[2]	bidir
51	P_CBE[2]	control

Order	Pin Names	Type
60	P_STOP#	control
61	P_PERR#	bidir
62	P_PERR#	control
63	P_LOCK#	input
64	P_SERR#	output
65	P_SERR#	control
66	P_AD[13]	bidir
67	P_AD[13]	control
68	P_AD[14]	bidir
69	P_AD[14]	control
70	P_AD[11]	bidir
71	P_AD[11]	control
72	P_AD[15]	bidir
73	P_AD[15]	control
74	P_AD[12]	bidir
75	P_AD[12]	control
76	P_AD[8]	bidir
77	P_AD[8]	control
78	P_CBE[1]	bidir
79	P_CBE[1]	control
80	P_AD[9]	bidir
81	P_AD[9]	control
82	P_AD[5]	bidir
83	P_AD[5]	control
84	P_M66EN	input
85	P_AD[6]	bidir
86	P_AD[6]	control
87	P_AD[2]	bidir
88	P_AD[2]	control
89	P_PAR	bidir
90	P_PAR	control
91	P_AD[0]	bidir
92	P_AD[0]	control
93	P_CBE[0]	bidir
94	P_CBE[0]	control
95	P_AD[7]	bidir
96	P_AD[7]	control
97	P_AD[10]	bidir
98	P_AD[10]	control
99	P_AD[1]	bidir
100	P_AD[1]	control
101	P_AD[3]	bidir
102	P_AD[3]	control
103	P_AD[4]	bidir
104	P_AD[4]	control
105	S1_AD[0]	bidir
106	S1_AD[0]	control
107	S1_AD[1]	bidir
108	S1_AD[1]	control
109	S1_AD[2]	bidir
110	S1_AD[2]	control
111	S1_AD[5]	bidir

Order	Pin Names	Type
52	P_FRAME#	bidir
53	P_FRAME#	control
54	P_IRDY#	bidir
55	P_IRDY#	control
56	P_TRDY#	bidir
57	P_DEVSEL#/P_TRDY#	control
58	P_DEVSEL#	bidir
59	P_STOP#	bidir
120	S1_AD[7]	control
121	S1_AD[6]	bidir
122	S1_AD[6]	control
123	S1_AD[8]	bidir
124	S1_AD[8]	control
125	S1_AD[9]	bidir
126	S1_AD[9]	control
127	S1_AD[10]	bidir
128	S1_AD[10]	control
129	S1_AD[11]	bidir
130	S1_AD[11]	control
131	S1_AD[12]	bidir
132	S1_AD[12]	control
133	S1_AD[14]	bidir
134	S1_AD[14]	control
135	S1_AD[13]	bidir
136	S1_AD[13]	control
137	S1_AD[15]	bidir
138	S1_AD[15]	control
139	S1_SERR#	input
140	S1_PAR	bidir
141	S1_PAR	control
142	S1_CBE[1]	bidir
143	S1_CBE[1]	control
144	S1_DEVSEL#	bidir
145	S1_DEVSEL#/S1_TRDY#	control
146	S1_STOP#	bidir
147	S1_STOP#	control
148	S1_LOCK#	bidir
149	S1_LOCK#	control
150	S1_PERR#	bidir
151	S1_PERR#	control
152	S1_FRAME#	bidir
153	S1_FRAME#	control
154	S1_IRDY#	bidir
155	S1_IRDY#	control
156	S1_TRDY#	bidir
157	S1_AD[17]	bidir
158	S1_AD[17]	control
159	S1_AD[16]	bidir
160	S1_AD[16]	control
161	S1_AD[20]	bidir
162	S1_AD[20]	control
163	S1_CBE[2]	bidir
164	S1_CBE[2]	control
165	S1_AD[19]	bidir
166	S1_AD[19]	control
167	S1_CBE[3]	bidir
168	S1_CBE[3]	control
169	S1_AD[23]	bidir
170	S1_AD[23]	control
171	S1_AD[26]	bidir

Order	Pin Names	Type
112	S1_AD[5]	control
113	S1_AD[3]	bidir
114	S1_AD[3]	control
115	S1_AD[4]	bidir
116	S1_AD[4]	control
117	S1_CBE[0]	bidir
118	S1_CBE[0]	control
119	S1_AD[7]	bidir
182	S1_AD[28]	control
183	S1_AD[30]	bidir
184	S1_AD[30]	control
185	S1_AD[31]	bidir
186	S1_AD[31]	control
187	S1_AD[27]	bidir
188	S1_AD[27]	control
189	S1_AD[24]	bidir
190	S1_AD[24]	control
191	S1_AD[18]	bidir
192	S1_AD[18]	control
193	S1_GNT#[0]	output
194	S1_GNT#[0]	control
195	S1_REQ#[0]	input
196	S1_REQ#[1]	input
197	S1_GNT#[1]	output
198	S1_GNT#[2]	output
199	S1_REQ#[2]	input
200	S1_REQ#[3]	input
201	S1_GNT#[3]	output
202	S1_GNT#[4]	output
203	S1_REQ#[4]	input
204	S1_REQ#[5]	input
205	S1_GNT#[5]	output
206	S1_GNT#[6]	output
207	S1_REQ#[6]	input
208	S1_REQ#[7]	input
209	S1_GNT#[7]	output
210	S1_RESET#	output
211	S2_AD[0]	bidir
212	S2_AD[0]	control
213	S2_AD[1]	bidir
214	S2_AD[1]	control
215	S2_AD[2]	bidir
216	S2_AD[2]	control
217	S2_AD[3]	bidir
218	S2_AD[3]	control
219	S2_AD[4]	bidir
220	S2_AD[4]	control
221	S2_AD[5]	bidir
222	S2_AD[5]	control
223	S2_AD[6]	bidir
224	S2_AD[6]	control
225	S2_AD[7]	bidir
226	S2_AD[7]	control
227	S2_CBE[0]	bidir
228	S2_CBE[0]	control
229	S2_AD[8]	bidir
230	S2_AD[8]	control
231	S2_AD[10]	bidir
232	S2_AD[10]	control
233	S2_AD[9]	bidir

Order	Pin Names	Type
172	S1_AD[26]	control
173	S1_AD[22]	bidir
174	S1_AD[22]	control
175	S1_AD[25]	bidir
176	S1_AD[25]	control
177	S1_AD[29]	bidir
178	S1_AD[29]	control
179	S1_AD[21]	bidir
180	S1_AD[21]	control
181	S1_AD[28]	bidir
244	S2_AD[15]	bidir
245	S2_AD[15]	control
246	S2_PAR	bidir
247	S2_PAR	control
248	S2_SERR#	input
249	S2_LOCK#	bidir
250	S2_LOCK#	control
251	S2_TRDY#	bidir
252	S2_DEVSEL#/S2_TRDY#	control
253	S2_STOP#	bidir
254	S2_STOP#	control
255	S2_IRDY#	bidir
256	S2_IRDY#	control
257	S2_CBE[2]	bidir
258	S2_CBE[2]	control
259	S2_AD[13]	bidir
260	S2_AD[13]	control
261	S2_AD[21]	bidir
262	S2_AD[21]	control
263	S2_PERR#	bidir
264	S2_PERR#	control
265	S2_AD[16]	bidir
266	S2_AD[16]	control
267	S2_FRAME#	bidir
268	S2_FRAME#	control
269	S2_DEVSEL#	bidir
270	S2_AD[19]	bidir
271	S2_AD[19]	control

Order	Pin Names	Type
272	S2_AD[17]	bidir
273	S2_AD[17]	control
274	S2_AD[18]	bidir
275	S2_AD[18]	control
276	S2_AD[20]	bidir
277	S2_AD[20]	control
278	S2_AD[22]	bidir
279	S2_AD[22]	control
280	S2_AD[24]	bidir
281	S2_AD[24]	control

Order	Pin Names	Type
234	S2_AD[9]	control
235	S2_AD[11]	bidir
236	S2_AD[11]	control
237	S1_M66EN	Input
238	S2_AD[12]	bidir
239	S2_AD[12]	control
240	S2_AD[14]	bidir
241	S2_AD[14]	control
242	S2_CBE[1]	bidir
243	S2_CBE[1]	control
282	S2_AD[23]	bidir
283	S2_AD[23]	control
284	S2_CBE[3]	bidir
285	S2_CBE[3]	control
286	S2_AD[25]	bidir
287	S2_AD[25]	control
288	S2_AD[26]	bidir
289	S2_AD[26]	control
290	S2_AD[28]	bidir
291	S2_AD[28]	control
292	S2_AD[27]	bidir
293	S2_AD[27]	control
294	S2_AD[29]	bidir
295	S2_AD[29]	control
296	S2_AD[30]	bidir
297	S2_AD[30]	control
298	S2_AD[31]	bidir
299	S2_AD[31]	control
300	S2_GNT#[0]	output
301	S2_GNT#[0]	control
302	S2_REQ#[0]	input
303	S2_REQ#[1]	input
304	S2_GNT#[1]	output
305	S2_GNT#[2]	output
306	S2_REQ#[2]	input
307	S2_REQ#[3]	input
308	S2_GNT#[3]	output
309	S2_GNT#[4]	output

Order	Pin Names	Type
310	S2_REQ#[4]	input
311	S2_REQ#[5]	input
312	S2_GNT#[5]	output
313	S2_GNT#[6]	output
314	S2_REQ#[6]	input

17 ELECTRICAL AND TIMING SPECIFICATIONS

17.1 MAXIMUM RATINGS

(Above which the useful life may be impaired. For user guidelines, not tested).

Storage Temperature	-65°C to 150°C
Ambient Temperature with Power Applied	-40°C to 85°C
Supply Voltage to Ground Potentials (Inputs and AV _{CC} , V _{DD} only)	-0.3V to 3.6V
DC Input Voltage	-0.5V to 3.6V

Note:

Stresses greater than those listed under MAXIMUM RATINGS may cause permanent damage to the device. This is a stress rating only and functional operation of the device at these or any conditions above those indicated in the operational sections of this specification is not implied. Exposure to absolute maximum rating conditions for extended periods of time may affect reliability.

17.2 3.3V DC SPECIFICATIONS

Symbol	Parameter	Condition	Min.	Max.	Units	Notes
V _{DD} , AV _{CC}	Supply Voltage		3	3.6	V	
V _{ih}	Input HIGH Voltage		0.5 V _{DD}	V _{DD} + 0.5	V	3
V _{il}	Input LOW Voltage		-0.5	0.3 V _{DD}	V	3
V _{ih}	CMOS Input HIGH Voltage		0.7 V _{DD}	V _{DD} + 0.5	V	1
V _{il}	CMOS Input LOW Voltage		-0.5	0.3 V _{DD}	V	1
V _{ipu}	Input Pull-up Voltage		0.7 V _{DD}		V	3
I _{ii}	Input Leakage Current	0 < V _{in} < V _{DD}		±10	µA	3
V _{oh}	Output HIGH Voltage	I _{out} = -500µA	0.9V _{DD}		V	3
V _{ol}	Output LOW Voltage	I _{out} = 1500µA		0.1 V _{DD}	V	3
V _{oh}	CMOS Output HIGH Voltage	I _{out} = -500µA	V _{DD} - 0.5		V	2
V _{ol}	CMOS Output LOW Voltage	I _{out} = 1500µA		0.5	V	2
C _{in}	Input Pin Capacitance			10	pF	3
C _{CLK}	CLK Pin Capacitance		5	12	pF	3
C _{IDSEL}	IDSEL Pin Capacitance			8	pF	3
L _{pin}	Pin Inductance			20	nH	3

Notes:

1. CMOS Input pins: S_CFN#, TCK, TMS, TDI, TRST#, SCAN_EN, SCAN_TM#
2. CMOS Output pin: TDO
3. PCI pins: P_AD[31:0], P_CBE[3:0], P_PAR, P_FRAME#, P_IRDY#, P_TRDY#, P_DEVSEL#, P_STOP#, P_LOCK#, PIDSEL#, P_PERR#, P_SERR#, P_REQ#, P_GNT#, P_RESET#, S1_AD[31:0], S2_AD[31:0], S1_CBE[3:0], S2_CBE[3:0], S1_PAR, S2_PAR, S1_FRAME#, S2_FRAME#, S1_IRDY#, S2_IRDY#, S1_TRDY#, S2_TRDY#, S1_DEVSEL#, S2_DEVSEL#, S1_STOP#, S2_STOP#, S1_LOCK#, S2_LOCK#, S1_PERR#, S2_PERR#, S1_SERR#, S2_SERR#, S1_REQ[7:0]#, S2_REQ[6:0]#, S1_GNT[7:0]#, S2_GNT[6:0], S1_RESET#, S2_RESET#, S1_EN, S2_EN, HSLED, HS_SW#, HS_EN, ENUM#.

17.3 3.3V AC SPECIFICATIONS

Figure 17-1 PCI SIGNAL TIMING MEASUREMENT CONDITIONS

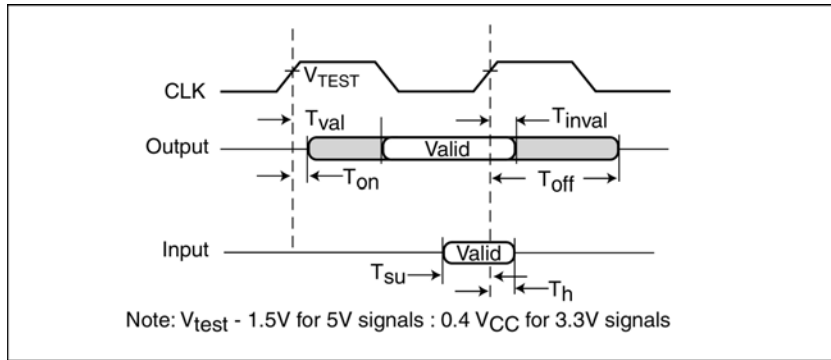

Symbol	Parameter	66 MHz		33 MHz		Units
		Min.	Max.	Min.	Max.	
T_{su}	Input setup time to CLK – based signals ^{1,2,3}	3	-	7	-	ns
$T_{su}(ptp)$	Input setup time to CLK – point-to-point ^{1,2,3}	5	-	10, 12 ⁴	-	
T_h	Input signal hold time from CLK ^{1,2}	0	-	0	-	
T_{val}	CLK to signal valid delay – based signals ^{1,2,3}	2	6	2	11	
$T_{val}(ptp)$	CLK to signal valid delay – point-to-point ^{1,2,3}	2	6	2	12	
T_{on}	Float to active delay ^{1,2}	2	-	2	-	
T_{off}	Active to float delay ^{1,2}	-	14	-	28	

- See Figure 17-1 PCI Signal Timing Measurement Conditions.
- All primary interface signals are synchronized to P_CLK. All secondary interface signals are synchronized to either S1_CLKOUT or S2_CLKOUT.
- Point-to-point signals are P_REQ#, S1_REQ#[7:0], S2_REQ#[6:0], P_GNT#, S1_GNT#[7:0], S2_GNT#[6:0], HSLED, HS_SW#, HS_EN, and ENUM#. Bused signals are P_AD, P_BDE#, P_PAR, P_PERR#, P_SERR#, P_FRAME#, P_IRDY#, P_TRDY#, P_LOCK#, P_DEVSEL#, P_STOP#, P_IDSEL, S1_AD, S1_CBE#, S1_PAR, S1_PERR#, S1_SERR#, S1_FRAME#, S1_IRDY#, S1_TRDY#, S1_LOCK#, S1_devsel#, S1_STOP#, S2_AD, S2_CBE#, S2_PAR, S2_PERR#, S2_SERR#, S2_FRAME#, S2_IRDY#, S2_TRDY#, S2_LOCK#, S2_DEVSEL#, and S2_STOP#.
- REQ# signals have a setup of 10 and GNT# signals have a setup of 12.

17.4 PRIMARY AND SECONDARY BUSES AT 66MHz CLOCK TIMING

Symbol	Parameter	Condition	Min.	Max.	Units
T _{SKEW}	SKEW among S1_CLKOUT[7:0]		0	250	ps
T _{SKEW}	SKEW among S2_CLKOUT[6:0]		0	250	
T _{DELAY}	DELAY between PCLK and S1_CLKOUT[7:0]	20pF load	3.3	4.9	ns
T _{DELAY}	DELAY between PCLK and S2_CLKOUT[6:0]	20pF load	3.3	4.9	
T _{CYCLE}	PCLK, S1_CLKOUT[7:0] cycle time		15	30	
T _{CYCLE}	PCLK, S2_CLKOUT[6:0] cycle time		15	30	
T _{HIGH}	PCLK, S1_CLKOUT[7:0] HIGH time		6		
T _{HIGH}	PCLK, S2_CLKOUT[6:0] HIGH time		6		
T _{LOW}	PCLK, S1_CLKOUT[7:0] LOW time		6		
T _{LOW}	PCLK, S2_CLKOUT[6:0] LOW time		6		

17.5 PRIMARY AND SECONDARY BUSES AT 33MHz CLOCK TIMING

Symbol	Parameter	Condition	Min.	Max.	Units
T _{SKEW}	SKEW among S1_CLKOUT[7:0]		0	250	ps
T _{SKEW}	SKEW among S2_CLKOUT[6:0]		0	250	
T _{DELAY}	DELAY between PCLK and S1_CLKOUT[7:0]	20pF load	3.3	4.9	ns
T _{DELAY}	DELAY between PCLK and S2_CLKOUT[6:0]	20pF load	3.3	4.9	
T _{CYCLE}	PCLK, S1_CLKOUT[7:0] cycle time		30		
T _{CYCLE}	PCLK, S2_CLKOUT[6:0] cycle time		30		
T _{HIGH}	PCLK, S1_CLKOUT[7:0] HIGH time		11		
T _{HIGH}	PCLK, S2_CLKOUT[6:0] HIGH time		11		
T _{LOW}	PCLK, S1_CLKOUT[7:0] LOW time		11		
T _{LOW}	PCLK, S2_CLKOUT[6:0] LOW time		11		

17.6 POWER CONSUMPTION

Parameter	Typical	Units
Power Consumption	2178	mW
Supply Current, I _{CC}	660	mA

Note: Typical values are at VCC = 3.3V, TA = 25°C, and all three ports running at 66MHz.

18 272-PIN PBGA PACKAGE FIGURE

Figure 18-1 272-PIN PBGA PACKAGE

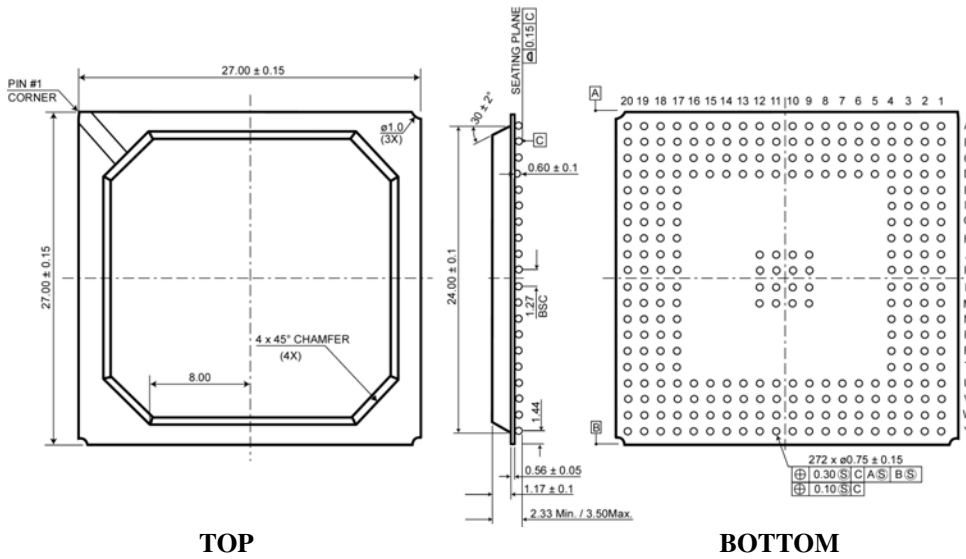

Thermal Characteristics can be found on the web: <http://www.pericom.com/packaging/mechanicals.php>

18.1 PART NUMBER ORDERING INFORMATION

Part Number	Pin – Package	Temperature
PI7C7300DNA	272 – PBGA	-40°C to 85°C
PI7C7300DNAE	272 – PBGA, Pb-free & Green	-40°C to 85°C