

Characteristics:

High Power, Compact Size

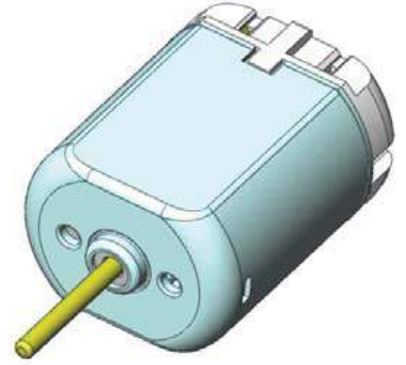

Specifications:

Dimensions (in)	: Ø 1.0 X 0.7 X 1.2 in
Shaft Diameter (in)	: Ø 0.079 in
Input Voltage (V)	: 24 V DC
No Load Speed (rpm)	: 12200 rpm
No Load Current (A)	: 0.10 A
Nominal Speed (rpm)	: 10200 rpm
Nominal Torque (lb.in)	: 0.08 lb.in
Nominal Current (A)	: 0.60 A
Stall Torque (lb.in)	: 0.50 lb.in
Stall Current (A)	: 3.30 A
Maximum Output Power (hp)	: 0.02 hp
Maximum Efficiency (%)	: 65.70 %
Torque (lb.in) - Max Eff	: 0.08 lb.in
Speed (rpm) - Max Eff	: 10200 rpm
Weight (oz)	: 1.4 oz
Operating Temperature Range (°F)	: 14 to 131 °F
Storage Temperature Range (°F)	: -4 to 176 °F
Electrical Connection	: Plug-in

Performance Data:

	No Load	Stall	Max Efficiency	Max Power
Current (A)	0.10	3.30	0.60	1.70
Efficiency (%)	-	-	65.70	44.60
Output Power (hp)	-	-	0.01	0.02
Speed (rpm)	12200.00	-	10200.00	6050.00
Torque (lb.in)	-	0.50	0.08	0.25

Application Examples:

Actuators

Drawing:

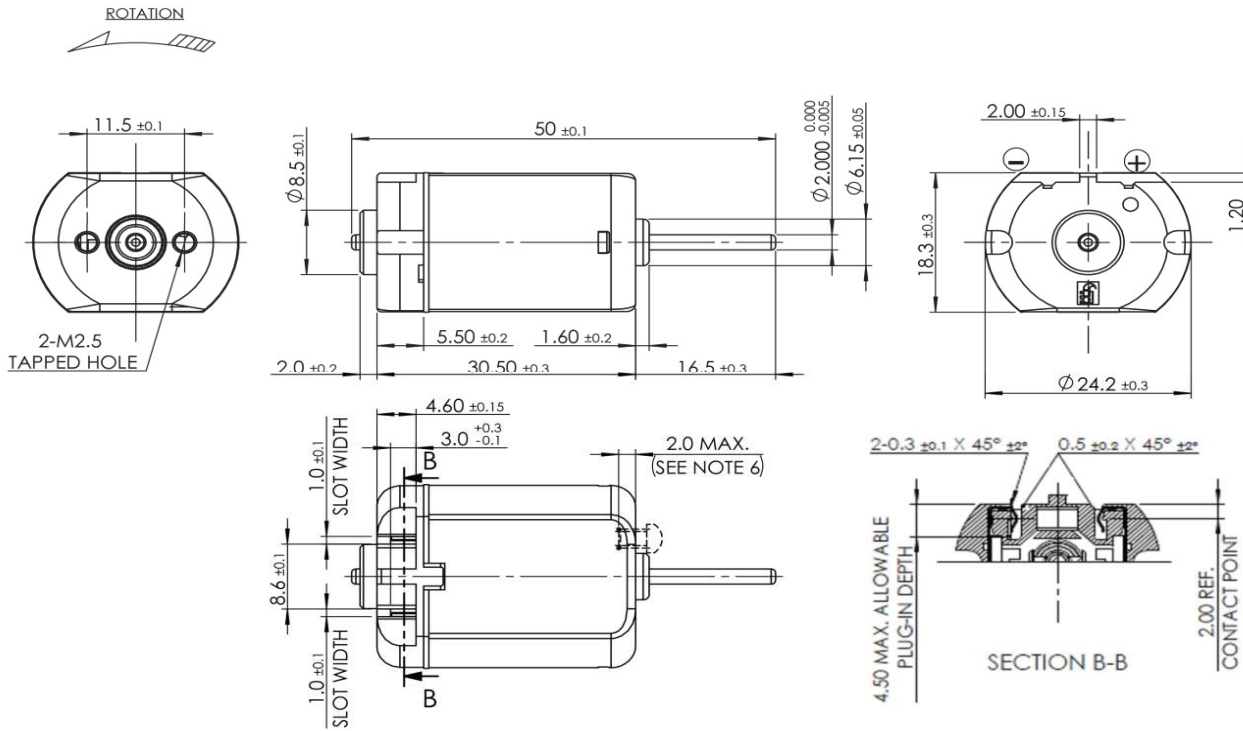

Performance Curves:

