

COMBO STRIP®

Metal Mesh Gasketing with Elastomer Weather Seal



Customer Value Proposition:

COMBO STRIP gaskets are a resilient, highly conductive sealing solution consisting of knitted wire mesh integrated with an elastomer weather seal.

With a track record of over 30 years worth of successful utilization in applications requiring weather sealing, EMI / EMP shielding and / or lightning strike protection, COMBO STRIP has established itself as a versatile and economical electrically conductive weather sealing solution in markets including military, telecommunications and aerospace.

Offered in a variety of standard material options and geometric sizes, COMBO STRIP can easily provide application specific performance without the additional costs associated with custom seal design and implementation.

Contact Information:

Parker Hannifin Corporation
Chomerics Division
77 Dragon Court
Woburn, MA 01801

phone 781 935 4850
fax 781 933 4318
chomailbox@parker.com

www.chomerics.com
www.parker.com/chomerics



Features and Benefits:

- Various standard and custom material and cross sectional geometry choices allow for application specific performance to be attained.
- High metal content ensures very good electrical performance for the seal.
- Knit construction provides durable, yet light-weight gasket performance.
- Various features available to eliminate wire mesh fraying, thereby eliminating foreign object debris concerns.
- Mesh affixation methods to the elastomer can be attained via bonding or overmolding, allowing for various degrees of overall seal durability and precision.
- Application specific design offerings ensure improved gasket performance, thereby reducing costs associated with seal replacement and application rework.
- High metal content results in a gasketing solution that can meet demanding requirements for both EMI shielding and current carrying, making this a solution that can be applied to a broader range of applications as compared to other electrically conductive gasketing options.
- Light-weight gasketing is an optimal solution for applications with weight or fuel savings requirements; parameters that are typically prevalent in the military and aerospace markets.
- Elimination of foreign object debris ensures costly application reworks due to electrical shorting can be avoided.
- Elastomer overmolding onto mesh ensures improved durability and tolerance schemes for applications requiring extremely high performance, whereas bonded options provide a more economical solution for less demanding applications.



ENGINEERING YOUR SUCCESS.

COMBO® Strip Gaskets - Product Information

Application Information:

COMBO STRIP gaskets are used to provide either EMI shielding, EMP resistance or lightning strike performance in unison with weather sealing capabilities for a variety of Military and Commercial applications. Five design variables should be considered when making a COMBO STRIP product selection. Each should be evaluated prior to gasket design to ensure optimal performance.

Wire Mesh

Numerous design criteria should be evaluated when selecting a wire mesh. The most critical of these criteria include galvanic compatibility, electrical performance, overall gasket durability and temperature range requirements.

Elastomer

Three specific design parameters are the most important variables to take into consideration when evaluating elastomer choices. These criteria are fluid exposure, temperature requirements and necessary compression characteristics of the material. Generally, solid elastomers are used in conjunction with cast or machined surfaces due to their larger force requirements for deflection. Sponge offerings have less force requirements for deflection and are therefore typically used in conjunction with sheet metal enclosures.

Geometric Profile

Geometric profile selection should be decided upon in parallel with elastomer material selection. Various design criteria should be evaluated. These criteria include, but are not limited to, gasket deflection percentage, necessary compression characteristics of the material, application load available for gasket deflection and planned gasket affixation method. To provide effective performance, it is recommended that gaskets be deflected 30 +/- 15% of their nominal height.

Foreign Object Debris

For applications with foreign object debris (FOD) requirements, Parker Chomerics provides terminated custom lengths with non-fraying ends by utilizing a variety of encapsulants including fluorosilicone, silicone, acrylic and urethane. Possible fluid exposures should be taken into consideration when choosing an encapsulant material to ensure long-term performance.

Miscellaneous

Typical fabricated gasket form factors for non-overmolded gaskets consist of corner splices utilizing RTV. For applications where a more robust solution is necessary, die-cutting sheeted elastomer material and then bonding the mesh is recommended. For applications in which over-compression at the bolt holes may occur, this can be avoided by bonding washer-type metal compression stops within the elastomer. Compression stop thickness should be targeted at the height which gives the finished gasket a nominal 30% deflection. For applications where a weather seal is not required, please refer to the MESH STRIP gasket data sheets.

COMBO® Strip Gaskets - Available Profiles

Contact Parker Chomerics for any other special requirements and an updated profile list.

Table 1

STANDARD MATERIAL SPECIFICATIONS							
Gasketing Types	ELASTOMERS				METALS		
	Silicone*		Neoprene*		Aluminum	Ferrex	Monel
	Solid	Closed Cell Sponge	Solid	Closed Cell Sponge			
COMBO STRIP®/COMBO® Gaskets (mesh/elastomer)	A-A-59588 Class 2B Grade 40	AMS-3195	MIL-R-6855 Class II, Grade 40	MIL-R-6130 Type II, Grade A, Condition Medium	Alloy 5056 AMS-4182*	**	QQ-N-281 AMS-4730

* Max tensile strength is 75,000 PSI

** Ferrex is Chomerics' tradename for tin-plated, copper-clad steel wire per ASTM B-520, ASTM (QQ-W-343) tin-plated, 2-3% by weight; ASTM B-227 copper-cladding 30-40% by weight; SAE 1010 steel wire, balance by weight.

Table 2

MATERIAL RANGES inches (mm)	
Mesh dimensions	Elastomer dimensions
min. [C]= 0.062 (1.57)	min. [A] = 0.062 (1.57)
[D]= 0.062 (1.57)	[B] = 0.125 (3.18)
max. [C]= 0.375 (9.53)	max. [A] = 0.375 (9.53)
[D]= 1.000 (25.4)	[B] = 1.000 (25.4)

Figure 2 COMBO STRIP Gasketing

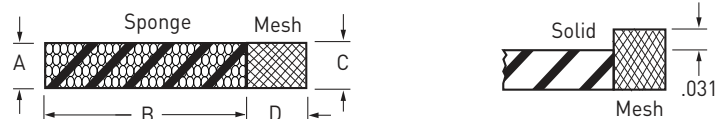

When using "solid" elastomer, mesh is normally 0.031in. (0.79mm) higher because mesh compresses easier than solid elastomer under same pressure.

Table 3

COMBO STRIP STANDARD GASKETING					
Dimensions inches (mm) (see Figure 2)				Part Number	
A	B	C	D	Neoprene Sponge	Silicone Sponge
0.062 (1.57)	0.250 (6.35)	0.062 (1.57)	0.125 (3.18)	01-020X-1756	01-030X-1772
0.062 (1.57)	0.375 (9.53)	0.062 (1.57)	0.125 (3.18)	01-020X-1757	01-030X-1773
0.062 (1.57)	0.500 (12.70)	0.062 (1.57)	0.125 (3.18)	01-020X-1692	01-030X-1774
0.062 (1.57)	0.625 (15.88)	0.062 (1.57)	0.125 (3.18)	01-020X-1739	01-030X-1775
0.093 (2.36)	0.250 (6.35)	0.093 (2.36)	0.125 (3.18)	01-020X-1344	01-030X-1776
0.093 (2.36)	0.375 (9.53)	0.093 (2.36)	0.125 (3.18)	01-020X-1332	01-030X-1777
0.093 (2.36)	0.500 (12.70)	0.093 (2.36)	0.125 (3.18)	01-020X-1758	01-030X-1778
0.093 (2.36)	0.750 (19.05)	0.093 (2.36)	0.125 (3.18)	01-020X-1333	01-030X-1779
0.125 (3.18)	0.125 (3.18)	0.125 (3.18)	0.125 (3.18)	01-020X-1138	01-030X-1780
0.125 (3.18)	0.188 (4.78)	0.125 (3.18)	0.125 (3.18)	01-020X-1136	01-030X-1781
0.125 (3.18)	0.250 (6.35)	0.125 (3.18)	0.125 (3.18)	01-020X-1135	01-030X-1782
0.125 (3.18)	0.250 (6.35)	0.125 (3.18)	0.250 (6.35)	01-020X-1130	01-030X-1783
0.125 (3.18)	0.375 (9.53)	0.125 (3.18)	0.125 (3.18)	01-020X-1132	01-030X-1784
0.125 (3.18)	0.500 (12.70)	0.125 (3.18)	0.125 (3.18)	01-020X-1134	01-030X-1785
0.125 (3.18)	0.500 (12.70)	0.125 (3.18)	0.250 (6.35)	01-020X-1131	01-030X-1786
0.125 (3.18)	0.500 (12.70)	0.125 (3.18)	0.500 (12.70)	01-020X-1133	01-030X-1787
0.125 (3.18)	0.625 (15.88)	0.125 (3.18)	0.125 (3.18)	01-020X-1055	01-030X-1788
0.125 (3.18)	0.750 (19.05)	0.125 (3.18)	0.125 (3.18)	01-020X-1759	01-030X-1789
0.188 (4.78)	0.188 (4.78)	0.188 (4.78)	0.125 (3.18)	01-020X-1760	01-030X-1790
0.188 (4.78)	0.250 (6.35)	0.156 (3.96)	0.125 (3.18)	01-020X-1056	01-030X-1515
0.188 (4.78)	0.250 (6.35)	0.188 (4.78)	0.125 (3.18)	01-020X-1622	01-030X-1791
0.188 (4.78)	0.375 (9.53)	0.188 (4.78)	0.125 (3.18)	01-020X-1761	01-030X-1792
0.188 (4.78)	0.500 (12.70)	0.188 (4.78)	0.125 (3.18)	01-020X-1762	01-030X-1793
0.188 (4.78)	0.750 (19.05)	0.188 (4.78)	0.250 (6.35)	01-020X-1763	01-030X-1794
0.250 (6.35)	0.250 (6.35)	0.250 (6.35)	0.125 (3.18)	01-020X-1764	01-030X-1795
0.250 (6.35)	0.500 (12.70)	0.250 (6.35)	0.125 (3.18)	01-020X-1766	01-030X-1797
0.250 (6.35)	0.750 (19.05)	0.250 (6.35)	0.125 (3.18)	01-020X-1767	01-030X-1798
0.375 (9.53)	0.250 (6.35)	0.375 (9.53)	0.125 (3.18)	01-020X-0817	01-030X-1800
0.375 (9.53)	0.500 (12.70)	0.375 (9.53)	0.250 (6.35)	01-020X-1768	01-030X-1801
0.375 (9.53)	0.750 (19.05)	0.375 (9.53)	0.250 (6.35)	01-020X-1769	01-030X-1802

For pressure-sensitive acrylic adhesive backing: change 02 to 06.

For pressure-sensitive acrylic adhesive backing: change 03 to 07.

Also available with solid neoprene or solid silicone, please inquire.



ENGINEERING YOUR SUCCESS.

COMBO® Strip Gaskets - Available Profiles

Ordering Procedure

Standard COMBO STRIP Gasketing: Standard roll length is 25 feet (7.62 meters). Contact Parker Chomerics about custom roll lengths. Order by part numbers from Tables 3 and 6 by replacing 'X' with **1** for Monel, **2** for Aluminum or **4** for Ferrex and then specify total length required per part. If no listed part is suitable, specify desired cross section, elastomer material, and EMI mesh material. Note the following size ranges:

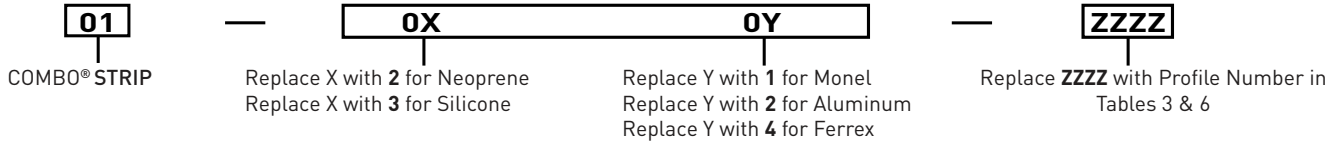

Table 4

FABRICATED COMBO GASKET TOLERANCES inches (mm)	
Dimensions*	Solid Elastomer
A, B, C & D for each 5.00 (127) of length	±0.015 (0.38)
G & J for each 5.00 (127) of length	±0.015 (0.38)
T 0.031 to 0.059 (0.78 - 1.50)	±0.012 (0.30)
T 0.060 to 0.124 (1.52 - 3.15)	±0.016 (0.41)
T 0.125 to 0.186 (3.18 - 4.72)	±0.020 (0.51)
T 0.187 to 0.374 (4.75 - 9.50)	±0.031 (0.78)
T 0.375 to 0.561 (9.52 - 14.2)	±0.047 (1.19)
W & H 0.062 to 0.186 (1.57 to 4.72)	+0.015 (+0.38), -0.000 (-0.00)
W & H 0.187 to 0.375 (4.75 to 9.53)	+0.031 (+0.78), -0.000 (-0.00)

FABRICATED COMBO GASKET TOLERANCES inches (mm)	
Dimensions*	Closed Cell Sponge
A, B, C & D for each 5.00 (127) of length	±0.015 (0.38)
G & J for each 5.00 (127) of length	±0.015 (0.38)
T Up To 0.063 (1.60)	+0.030 (0.76), -0.016 (0.41)
T 0.064 to 0.188 (1.62 to 4.78)	±0.031 (0.76)
T 0.189 to 0.313 (4.80 to 7.95)	+0.050 (1.27), -0.030 (0.76)
T 0.314 to 0.500 (7.97 to 12.7)	±0.060 (1.52)
W & H 0.062 to 0.186 (1.57 to 4.72)	+0.015 (+0.38), -0.000 (-0.00)
W & H 0.187 to 0.375 (4.75 to 9.53)	+0.031 (+0.78), -0.000 (-0.00)

*See sketch.

*See sketch.

Figure 3 Typical Fabricated COMBO Gasket Drawing

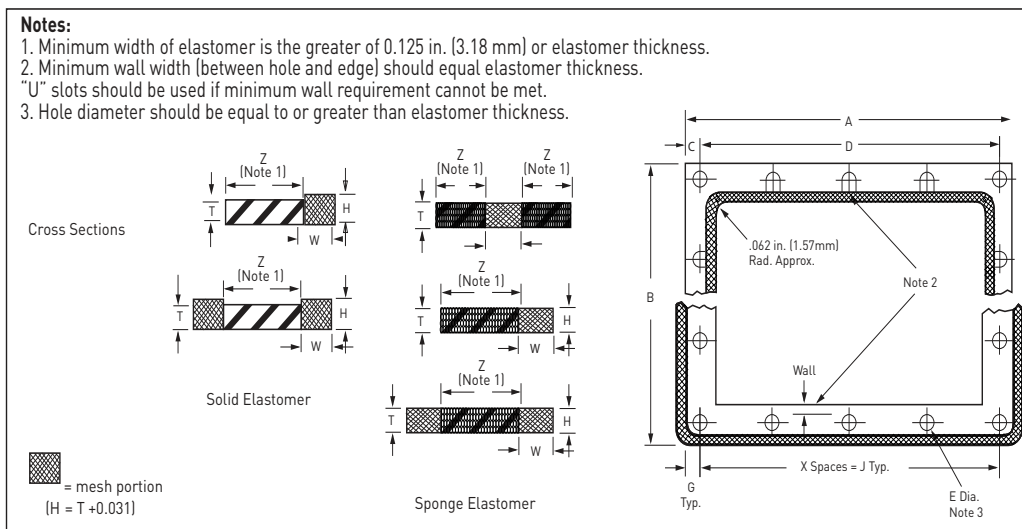

COMBO® Strip Gaskets - Available Profiles

Table 5

COMBO AND COMBO-2 STRIP CROSS SECTION TOLERANCES inches (mm)	
Dimensions*	Solid Elastomer
A Up To 0.030 (.76) 0.031 to 0.059 (0.79 - 1.50) 0.060 to 0.124 (1.52 - 3.15) 0.125 to 0.186 (3.18 - 4.72) 0.187 to 0.374 (4.75 - 9.50) 0.375 to 0.561 (9.53 - 14.25) 0.562 to 0.749 (14.28 - 19.03) 0.750 to 0.999 (19.05 - 25.38) Over 0.999 (25.38)	±0.010 (0.25) ±0.012 (0.31) ±0.016 (0.41) ±0.020 (0.51) ±0.031 (0.79) ±0.047 (1.19) ±0.063 (1.60) ±0.093 (2.36) ±10 %
B Under 1.00 (25.4)	±0.031 (0.78)
C & D 0.062 to 0.186 (1.57 to 4.72) 0.187 to 0.375 (4.75 to 9.53)	+0.015 (+0.38) -0.000 (-0.00) +0.031 (+0.78) -0.000 (-0.00)

*See sketch.

COMBO AND COMBO-2 STRIP CROSS SECTION TOLERANCES inches (mm)	
Dimensions*	Closed Cell Sponge
A Up To 0.063 (1.60) 0.064 to 0.188 (1.64 to 4.78) 0.189 to 0.313 (4.80 to 7.95) 0.314 to 0.500 (7.98 to 12.7) 0.501 to 0.750 (12.76 to 19.05) Over 0.750 (19.05)	+0.030 (0.76), -0.016 (0.41) ±0.031 (0.76) +0.050 (1.27), -0.030 (0.76) ±0.060 (1.52) ±0.090 (2.29) ±0.120 (3.05)
B Under 1.00 (25.4)	±0.094 (2.39)
C & D 0.062 to 0.186 (1.57 to 4.72) 0.187 to 0.375 (4.75 to 9.53)	+0.015 (+0.38) -0.000 (-0.00) +0.031 (+0.78) -0.000 (-0.00)

*See sketch.

Figure 4 COMBO-2 STRIP Gasketing

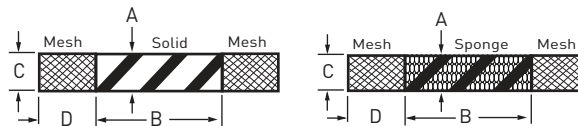

Table 6

COMBO-2 STRIP GASKETS					
Dimensions inches (mm)				Part Number	
				Neoprene Sponge	Silicone Sponge
A	B	C	D		
0.125 (3.18)	0.250 (6.35)	0.125 (3.18)	0.125 (3.18)	01-020X-1765	01-030X-1796
0.125 (3.18)	0.375 (9.53)	0.125 (3.18)	0.125 (3.18)	01-020X-1770	01-030X-1799
0.125 (3.18)	0.500 (12.70)	0.125 (3.18)	0.125 (3.18)	01-020X-1771	01-030X-1803
0.125 (3.18)	0.250 (6.35)	0.156 (3.96)	0.250 (6.35)	01-020X-1804	01-030X-1805
0.125 (3.18)	0.375 (9.53)	0.156 (3.96)	0.125 (3.18)	01-020X-1681	01-030X-1806
0.125 (3.18)	0.500 (12.70)	0.156 (3.96)	0.125 (3.18)	01-020X-1807	01-030X-1810
0.188 (4.78)	0.250 (6.35)	0.188 (4.78)	0.125 (3.18)	01-020X-1808	01-030X-1811
0.188 (4.78)	0.500 (12.70)	0.188 (4.78)	0.125 (3.18)	01-020X-1809	01-030X-1812

For pressure-sensitive acrylic adhesive backing: change 02 to 06.

For pressure-sensitive acrylic adhesive backing: change 03 to 07.

www.chomerics.com
www.parker.com/chomerics

CHOMERICS is a registered trademarks of Parker Hannifin Corporation. © 2012

TB 1128 EN May 2017



ENGINEERING YOUR SUCCESS.