

## Low Skew, 1-To-6 LVC MOS / LV TTL Fanout Buffer

### Features

- 6 LVC MOS / LV TTL outputs
- LVC MOS / LV TTL clock input accepts LVC MOS or LV TTL input levels
- Maximum output frequency: 250MHz
- Part-to-part skew: 250ps (typical)
- Full 3.3V, 2.5V, 1.8V operation mode, or 3.3V/ 2.5V/ 1.8V core with 2.5V, 1.8V, 1.5V supply modes
- -40°C to 85°C ambient operating temperature
- Lead-Free package fully RoHS compliant

### Description

The PI6C49X0206T is a low skew, 1-to-6 LVC MOS/LV TTL High Performance Fanout Buffer. The PI6C49X0206T has a single ended clock input. The single ended clock input accepts LVC MOS or LV TTL input levels. The PI6C49X0206T features a pair of LVC MOS/LV TTL outputs. Guaranteed output and part-to-part skew characteristics make the PI6C49X0206T ideal for clock distribution applications demanding well defined performance and repeatability.

### Block Diagram

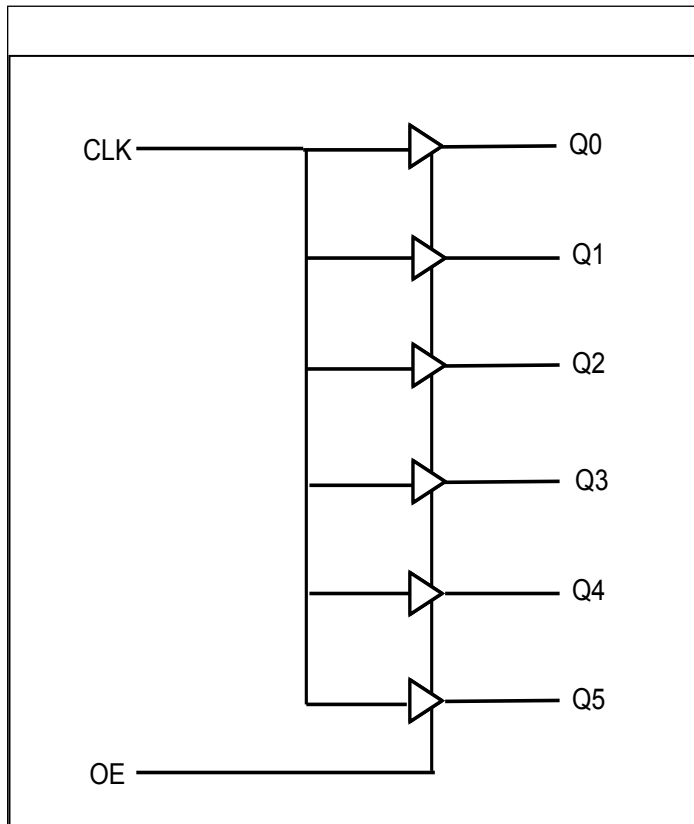

### Pin Assignment

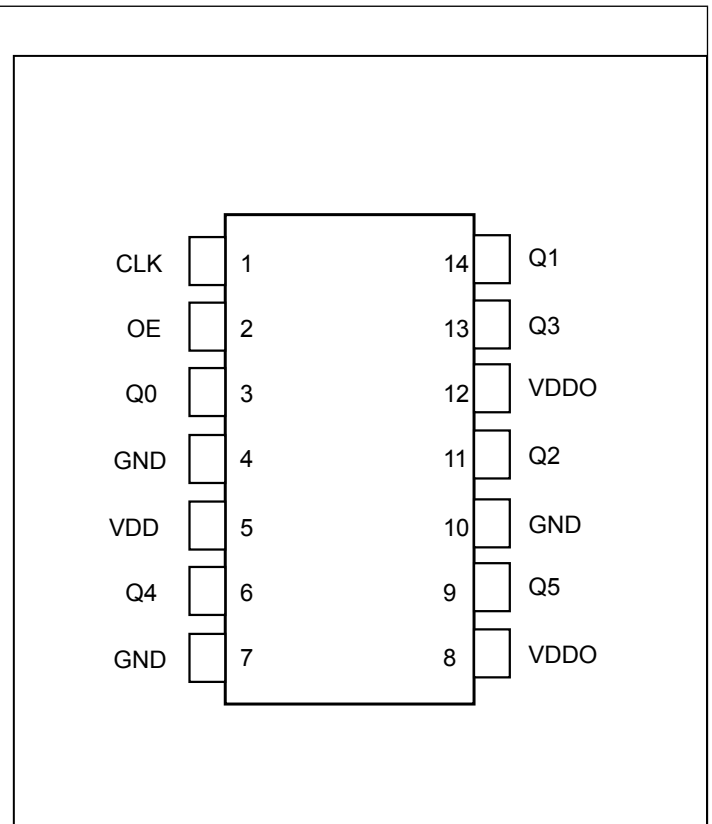

**Pin Descriptions**

Pin#	Pin Name	Pin Type		Pin Description
1	CLK	Input	Pulldown	LVCMOS / LVTTL clock input.
2	OE	Input		Output Enable pin
3, 6, 9, 11, 13, 14	Q0, Q4, Q5, Q2, Q3, Q1	Output		Single clock output. LVCMOS / LVTTL interface levels.
4, 7, 10	GND	Power		Power supply ground.
5	VDD	Power		Core supply pins.
8, 12	VDDO	Power		Output supply pins.

Note: *Pulldown* refer to internal input resistors, typical values in Pin Characteristics table.

**Output Logic**

Inputs		Output
CLK	OE	Qn
X	L	L
L	H	L
H	H	H

**Pin Characteristics**

Symbol	Parameter	Test Conditions	Min.	Typical	Max.	Units
$C_N$	Capacitance			4		pF
$R_{PULLDOWN}$	Input Pulldown Resistor			51		k $\Omega$

**Maximum Ratings**

(Above which useful life may be impaired. For user guidelines, not tested.)

Maximum Supply Voltage, VDD, VDDO .....	4.6V
Inputs, $V_I$ .....	-0.5V to VDD+0.5V
Output, $V_O$ .....	-0.5V to VDDO+0.5V
Storage Temperature .....	-65°C to 150°C
ESD Protection (HBM).....	2000V

Note:

Stresses beyond those listed under Absolute Maximum Ratings may cause permanent damage to the device. These ratings are stress specifications only. Functional operation of product at these conditions or any conditions beyond those listed in the DC Characteristics or AC Characteristics is not implied. Exposure to absolute maximum rating conditions for extended periods may affect product reliability.

**POWER SUPPLY DC CHARACTERISTICS,  $T_A = -40^\circ\text{C}$  to  $85^\circ\text{C}$** 

Symbol	Parameter	Conditions	Min.	Typ.	Max.	Units
VDD	Core Supply Voltage	3.3V Operation	3.135	3.3	3.465	V
		2.5V Operation	2.375	2.5	2.625	
		1.8V Operation	1.6	1.8	2.0	
VDDO	Output Power Supply Voltage	3.3V Supply	3.135	3.3	3.465	V
		2.5V Supply	2.375	2.5	2.625	
		1.8V Supply	1.6	1.8	2.0	
		1.5V Supply	1.425	1.5	1.575	
IDD	Power Supply Current	no load			2	mA
IDDO	Output Supply Current	5pF load, 25MHz, VDDO=3.3V		6	9.5	mA
		5pF load, 25MHz, VDDO=2.5V		5.7	7.2	mA
		5pF load, 25MHz, VDDO=1.8V		4.5	5.5	mA
		5pF load, 25MHz, VDDO=1.5V		3.5	4.6	mA
		5pF load, 200MHz, VDDO=3.3V		57	72	mA
		5pF load, 200MHz, VDDO=2.5V		44	54	mA
		5pF load, 200MHz, VDDO=1.8V		32	39	mA
		5pF load, 200MHz, VDDO=1.5V		19	24	mA

**LVCMOS / LVTTTL DC CHARACTERISTICS,  $T_A = -45^{\circ}\text{C}$  to  $85^{\circ}\text{C}$** 

Symbol	Parameter	Conditions	Min.	Typ.	Max.	Units		
$V_{IH}$	Input High Voltage	VDD = 3.3V	2		VDD+0.3	V		
		VDD = 2.5V	1.7		VDD+0.3			
		VDD = 1.8V	0.65*VDD		VDD+0.3			
$V_{IL}$	Input Low Voltage	VDD = 3.3V	-0.3		0.8	V		
		VDD = 2.5V	-0.3		0.8			
		VDD = 1.8V	-0.3		0.35*VDD			
$I_{IH}$	Input High Current	VDD = $V_{IN} = 3.465\text{V}$			150	$\mu\text{A}$		
		VDD = $V_{IN} = 2.625\text{V}$			150			
		VDD = $V_{IN} = 2.0\text{V}$			150			
$I_{IL}$	Input Low Current	VDD = 3.465V, $V_{IN} = 0\text{V}$	-5			$\mu\text{A}$		
		VDD = 2.625V, $V_{IN} = 0\text{V}$	-5					
		VDD = 2.0V, $V_{IN} = 0\text{V}$	-5					
$V_{OH}$	Output High Voltage	VDDO = 3.3V	50 $\Omega$ to VDDO / 2	2.6			V	
			$I_{OH} = -100\mu\text{A}$	2.9			V	
		VDDO = 2.5V	50 $\Omega$ to VDDO / 2	1.8				V
			$I_{OH} = -100\mu\text{A}$	2.2				V
		VDDO = 1.8V	50 $\Omega$ to VDDO / 2	1.2				V
			$I_{OH} = -100\mu\text{A}$	1.6				V
VDDO = 1.5V	50 $\Omega$ to VDDO / 2	0.96				V		
	$I_{OH} = -100\mu\text{A}$	1.3				V		
$V_{OL}$	Output Low Voltage	VDDO = 3.3V	50 $\Omega$ to VDDO / 2			0.6	V	
			$I_{OL} = 100\mu\text{A}$			0.2	V	
		VDDO = 2.5V	50 $\Omega$ to VDDO / 2			0.6	V	
			$I_{OL} = 100\mu\text{A}$			0.2	V	
		VDDO = 1.8V	50 $\Omega$ to VDDO / 2			0.6	V	
			$I_{OL} = 100\mu\text{A}$			0.2	V	
VDDO = 1.5V	50 $\Omega$ to VDDO / 2			0.6	V			
	$I_{OL} = 100\mu\text{A}$			0.2	V			

**AC CHARACTERISTICS**, VDD = 3.3V ± 5%, T<sub>A</sub> = -45°C to 85°C

Symbol	Parameter	Conditions	Min.	Typ.	Max.	Units
f <sub>MAX</sub>	Output Frequency	VDDO = 3.3V			250	MHz
		VDDO = 2.5V			250	
		VDDO = 1.8V			250	
		VDDO = 1.5V			250	
tp <sub>LH</sub>	Propagation Delay, Low-to-High; NOTE 1	VDDO = 3.3V, f ≤ 250MHz	1.2	1.6	2.8	ns
		VDDO = 2.5V, f ≤ 250MHz	1.45	1.9	3.3	
		VDDO = 1.8V, f ≤ 250MHz	2.2	2.8	3.6	
		VDDO = 1.5V, f ≤ 250MHz	3.25	4	4.7	
tsk(o)	Output Skew; NOTE 2	VDDO = 2.5V, 3.3V		68	100	ps
		VDDO = 1.5V, 1.8V		80	150	ps
tsk(pp)	Part-to-Part Skew; NOTE 3			250	800	ps
t <sub>R</sub>	Output Rise Time NOTE 4	VDDO = 3.3V	300		800	ps
		VDDO = 2.5V	300		800	
		VDDO = 1.8V	300		800	
		VDDO = 1.5V	600		1000	
t <sub>F</sub>	Output Fall Time NOTE 4	VDDO = 3.3V	300		800	ps
		VDDO = 2.5V	300		800	
		VDDO = 1.8V	300		800	
		VDDO = 1.5V	600		1000	
odc	Output Duty Cycle	f ≤ 133MHz	45		55	%
		133MHz < f ≤ 250MHz	40		60	%
t <sub>jit</sub>	Additive RMS Jitter	156.25MHz (@12kHz to 20MHz)		0.03		ps
		125MHz (@12kHz to 20MHz)		0.05		ps
t <sub>OED</sub>	Output Disable Time				6	ns
t <sub>OE</sub>	Output Enable Time				6	ns

Parameters measured at f<sub>MAX</sub> unless otherwise noted.

NOTE 1: Measured from VDD / 2 of the input to VDDO / 2 of the output.

NOTE 2: Defined as skew between outputs at the same supply voltage and with equal load conditions. Measured at VDDO / 2.

NOTE 3: Defined as skew between outputs on different devices operating at the same supply voltages and with equal load conditions. Using the same type of inputs on each device, the outputs are measured at VDDO / 2.

NOTE 4: Defined from 20% to 80%

**AC CHARACTERISTICS**, VDD = 2.5V ± 5%, T<sub>A</sub> = -45°C to 85°C

Symbol	Parameter	Conditions	Min.	Typ.	Max.	Units
f <sub>MAX</sub>	Output Frequency	VDDO = 2.5V			250	MHz
		VDDO = 1.8V			250	
		VDDO = 1.5V			250	
tp <sub>LH</sub>	Propagation Delay, Low-to-High; NOTE 1	VDDO = 2.5V, f ≤ 250MHz	1.56	2	2.7	ns
		VDDO = 1.8V, f ≤ 250MHz	2.3	2.9	3.7	
		VDDO = 1.5V, f ≤ 250MHz	3.34	4	4.83	
tsk(o)	Output Skew; NOTE 2	VDDO = 1.8V, 2.5V		68	100	ps
		VDDO = 1.5V		80	150	ps
tsk(pp)	Part-to-Part Skew; NOTE 3			250	800	ps
t <sub>R</sub>	Output Rise Time NOTE 4	VDDO = 2.5V	300		800	ps
		VDDO = 1.8V	300		800	
		VDDO = 1.5V	500		1000	
t <sub>F</sub>	Output Fall Time NOTE 4	VDDO = 2.5V	300		800	ps
		VDDO = 1.8V	300		800	
		VDDO = 1.5V	500		1000	
odc	Output Duty Cycle	f ≤ 133MHz	45		55	%
		133MHz < f ≤ 250MHz	40		60	%
t <sub>jit</sub>	Additive RMS Jitter	156.25MHz (@12kHz to 20MHz)		0.03		ps
		125MHz (@12kHz to 20MHz)		0.05		ps
t <sub>OED</sub>	Output Disable Time				10	ns
t <sub>OE</sub>	Output Enable Time				10	ns

Parameters measured at f<sub>MAX</sub> unless otherwise noted.

NOTE 1: Measured from VDD / 2 of the input to VDDO / 2 of the output.

NOTE 2: Defined as skew between outputs at the same supply voltage and with equal load conditions. Measured at VDDO / 2.

NOTE 3: Defined as skew between outputs on different devices operating at the same supply voltages and with equal load conditions. Using the same type of inputs on each device, the outputs are measured at VDDO / 2.

NOTE 4: Defined from 20% to 80%

**AC CHARACTERISTICS**,  $V_{DD} = 1.8V \pm 0.2V$ ,  $T_A = -45^{\circ}C$  to  $85^{\circ}C$ 

Symbol	Parameter	Conditions	Min.	Typ.	Max.	Units
$f_{MAX}$	Output Frequency	VDDO = 1.8V			250	MHz
		VDDO = 1.5V			250	
$t_{pLH}$	Propagation Delay, Low-to-High; NOTE 1	VDDO = 1.8V, $f \leq 250MHz$	2.57	3.25	4	ns
		VDDO = 1.5V, $f \leq 250MHz$	3.57	4.3	5.1	
$tsk(o)$	Output Skew; NOTE 2	VDDO = 1.8V		68	100	ps
		VDDO = 1.5V		80	150	ps
$tsk(pp)$	Part-to-Part Skew; NOTE 3			250	800	ps
$t_r$	Output Rise Time NOTE 4	VDDO = 1.8V	300		800	ps
		VDDO = 1.5V	500		1000	
$t_f$	Output Fall Time NOTE 4	VDDO = 1.8V	300		800	ps
		VDDO = 1.5V	500		1000	
odc	Output Duty Cycle	$f \leq 133MHz$	45		55	%
		$133MHz < f \leq 250MHz$	40		60	%
$t_{jit}$	Additive RMS Jitter	156.25MHz (@12kHz to 20MHz)		0.03		ps
		125MHz (@12kHz to 20MHz)		0.06		ps
$t_{OED}$	Output Disable Time				14	ns
$t_{OE}$	Output Enable Time				14	ns

Parameters measured at  $f_{MAX}$  unless otherwise noted.

NOTE 1: Measured from VDD /2 of the input to VDDO /2 of the output.

NOTE 2: Defined as skew between outputs at the same supply voltage and with equal load conditions. Measured at VDDO /2.

NOTE 3: Defined as skew between outputs on different devices operating at the same supply voltages and with equal load conditions. Using the same type of inputs on each device, the outputs are measured at VDDO /2.

NOTE 4: Defined from 20% to 80%

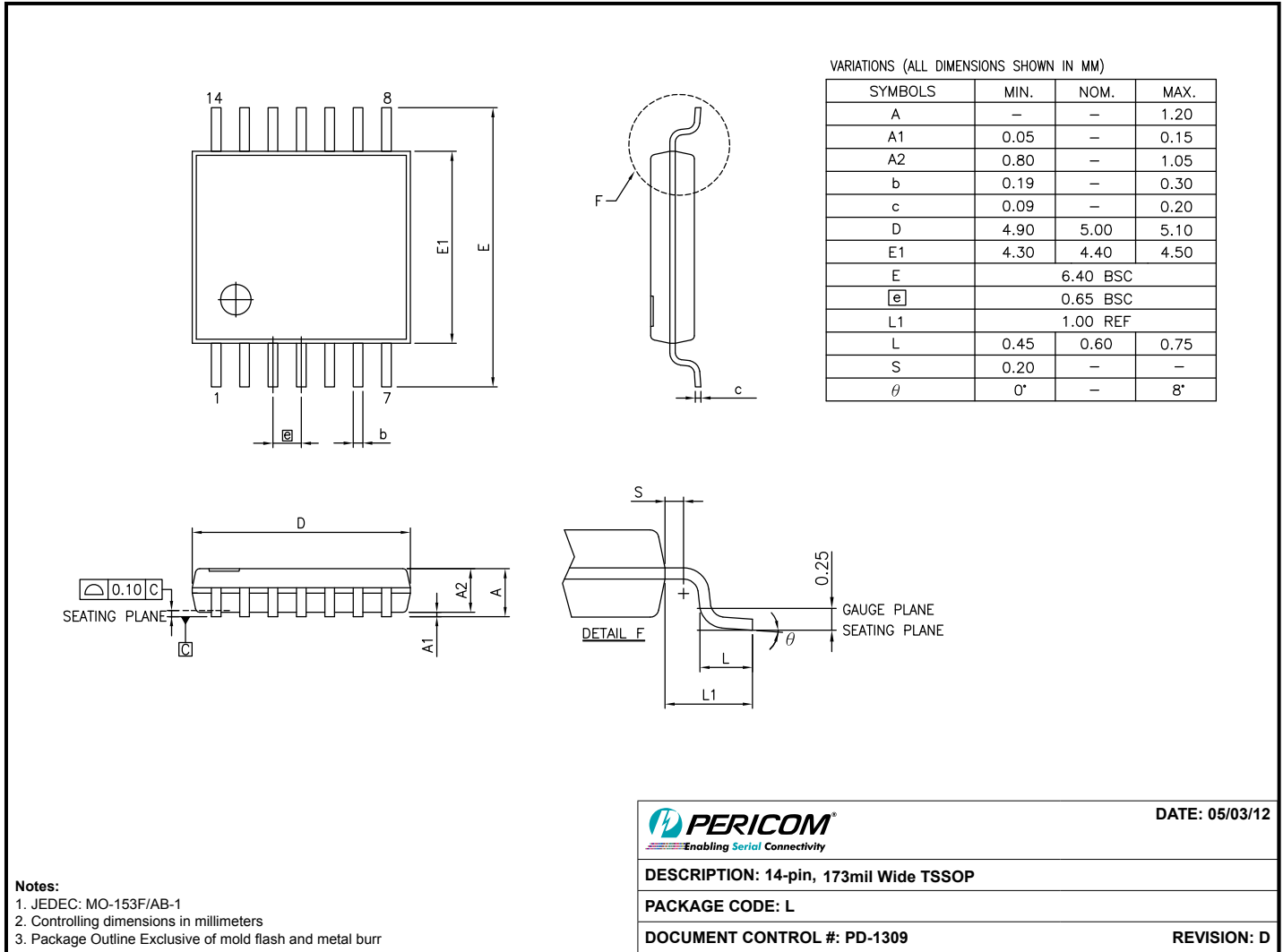

<b>PERICOM</b> Enabling Serial Connectivity	DATE: 05/03/12
<b>DESCRIPTION: 14-pin, 173mil Wide TSSOP</b>	
<b>PACKAGE CODE: L</b>	
<b>DOCUMENT CONTROL #: PD-1309</b>	<b>REVISION: D</b>

**Note:**  
 • For latest package info, please check: <http://www.pericom.com/products/packaging/mechanicals.php>

### Ordering Information<sup>(1-3)</sup>

Ordering Code	Package Code	Package Description
PI6C49X0206TLIE	L	14-pin, Pb-free & Green, TSSOP
PI6C49X0206TLIEX	L	14-pin, Pb-free & Green, TSSOP, Tape & Reel

- Notes:**
1. Thermal characteristics can be found on the company web site at [www.pericom.com/packaging/](http://www.pericom.com/packaging/)
  2. E = Pb-free and Green
  3. Adding an X suffix = Tape/Reel