

AMPHENOL PART NUMBER  
CONFIGURATION  
UE86-3G2420-X0361

**LIGHT PIPE OPTION**

- 0 - NO LIGHT PIPE
- 1 - 4 LP PER 2X1, NORMAL ORIENTATION
- 2 - 2 INNER LP PER 2X1, NORMAL ORIENTATION
- 3 - 2 OUTER LP PER 2X1, NORMAL ORIENTATION
- 4 - 4 LP PER 2X1, REVERSING ORIENTATION
- 5 - 2 INNER LP PER 2X1, REVERSING ORIENTATION
- 6 - 2 OUTER LP PER 2X1, REVERSING ORIENTATION
- 7 - 3 LP PER 2X1, 2 OUTER LP, NORMAL ORIENTATION
- 8 - 3 LP PER 2X1, 2 OUTER LP, REVERSING ORIENTATION

**PACKAGING**  
1 - TRAY PACKAGING (STACKED)

- PLATING OPTIONS FOR CONNECTOR**
- 2 - 30µ" GOLD PLATING ON MATING AREA  
15~100µ" MATTE TIN ON TERMINATION
  - 3 - 30µ" GOLD PLATING ON MATING AREA  
150~300µ" MATTE TIN ON TERMINATION
  - 5 - 15µ" GOLD PLATING ON MATING AREA  
15~100µ" MATTE TIN ON TERMINATION
  - 6 - 15µ" GOLD PLATING ON MATING AREA  
150~300µ" MATTE TIN ON TERMINATION

PART NUMBER  
(LAST DIGIT INDICATING  
PACKAGING TYPE, NOT  
PRINTED ON THE PART)

DATE CODE

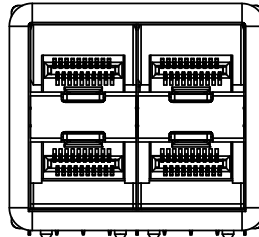
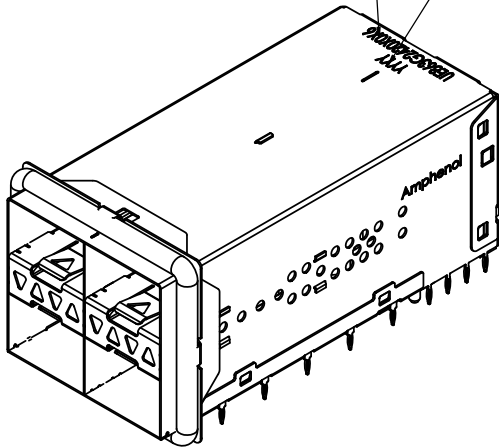

NO LIGHT PIPES  
UE86-3G2420-00X61

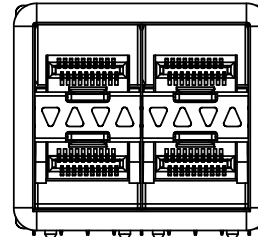

4 LIGHT PIPES  
UE86-3G2420-10X61

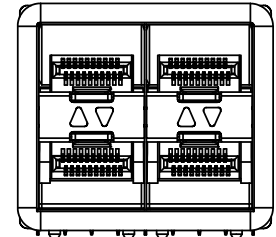

2 INNER LIGHT PIPES  
UE86-3G2420-20X61

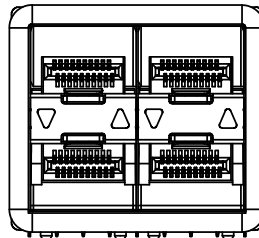

2 OUTER LIGHT PIPES  
UE86-3G2420-30X61

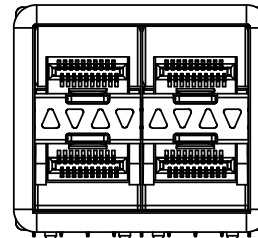

4 LIGHT PIPES UPSIDE DOWN  
UE86-3G2420-40X61

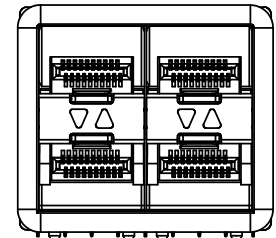

2 INNER LIGHT PIPES UPSIDE DOWN  
UE86-3G2420-50X61

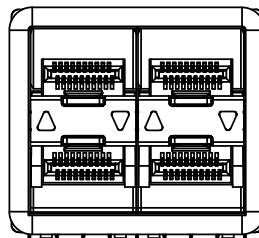

2 OUTER LIGHT PIPES UPSIDE DOWN  
UE86-3G2420-60X61

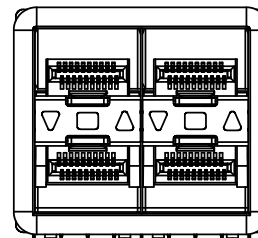

3 LIGHT PIPES  
UE86-3G2420-70X61

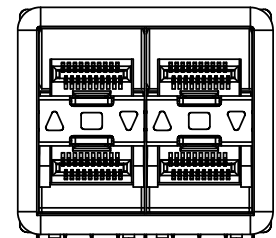

3 LIGHT PIPES UPSIDE DOWN  
UE86-3G2420-80X61

**MATERIAL: (RoHS COMPLIANT)**

1. CAGE - PRESS FIT: COPPER ALLOY (NICKEL SILVER)
2. CONNECTOR - PRESS FIT:  
- PLASTIC HOUSING: LCP, FLAMMABILITY RATING UL94-V0.  
- CONTACTS: PHOSPHOR BRONZE
3. LIGHT PIPE: CLEAR POLYCARBONATE, FLAMMABILITY RATING UL94-V0.
4. PACKAGING: TRAY PACKAGING.
5. TEMPERATURE RANGE: -40°C TO +85°C
6. EMI GASKET: CONDUCTIVE ELASTOMER UL94-V0



UNLESS SPECIFIED OTHERWISE	DRAWN	P. OU	FEB10/14
DIMENSIONS ARE IN MILLIMETERS	CHECKED	J. SI	FEB 12/14
REFERENCE IN PARENTHESES	M.E. APP'D		
GENERAL TOLERANCES	Q.A. APP'D		
1 DECIMAL PLACE ±0.25	DWG APP'D	J. SI	FEB 12/14
2 DECIMAL PLACE ±0.15	MATERIAL AND FINISH	SEE NOTES	
3 DECIMAL PLACE N/A	REF.	ECN Exxxxx	
ANGULAR DEGREES ±1°	THIRD ANGLE PROJECTION	DO NOT SCALE DRAWING	
ENG. REL. NO.			

**Amphenol High Speed Interconnects**  
A Division of Amphenol Corp. www.amphenolcanada.com

**2X2 SFP ULTRAPORT WITH LIGHT PIPE OPTIONS  
AND EMI GASKET**

DWG. NO.	P-UE86-3G2420-X0361			REV C
CODE ID NO.	03554	DWG SIZE: C	SCALE: 2:1	SHEET 1 OF 4

REVISIONS				
REV.	ECN	DESCRIPTION	DATE	APPROVED
A		INITIAL RELEASE	10/02/2014	J.S
B		UPDATE PLATING OPTIONS	JUN 25/14	J.S
C		UPDATE NOTES	AUG 14/15	J.S

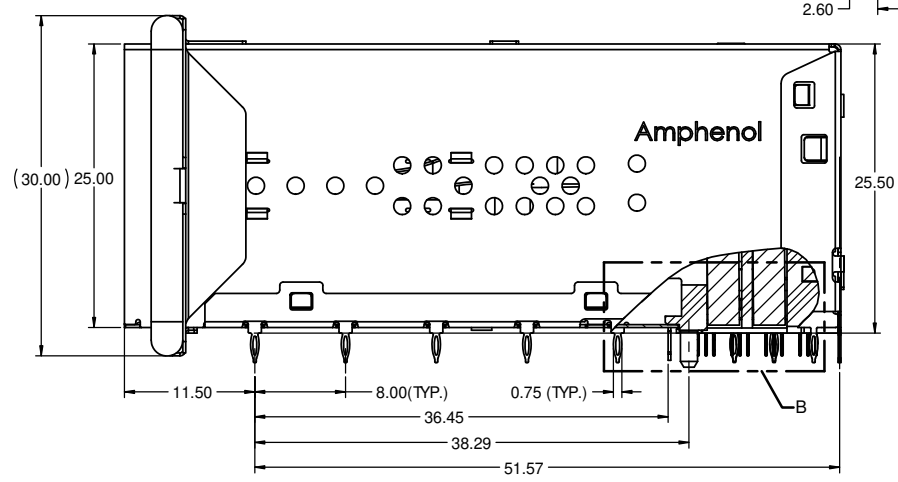
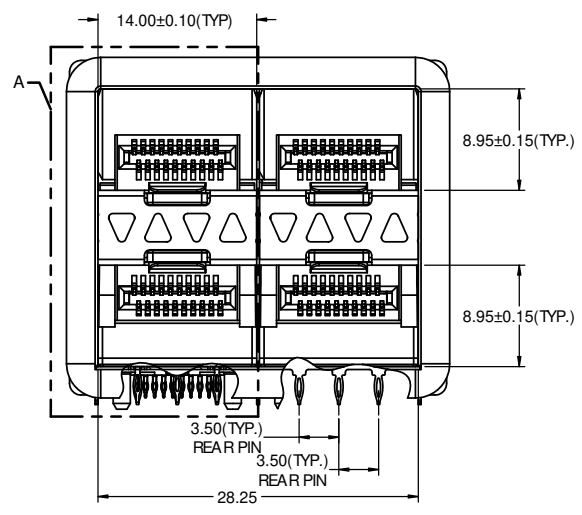
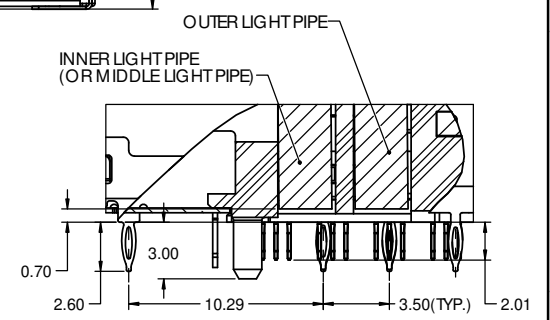
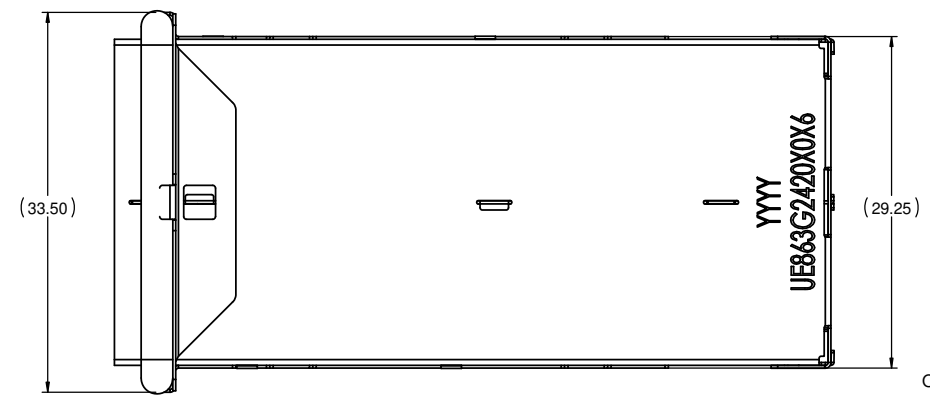
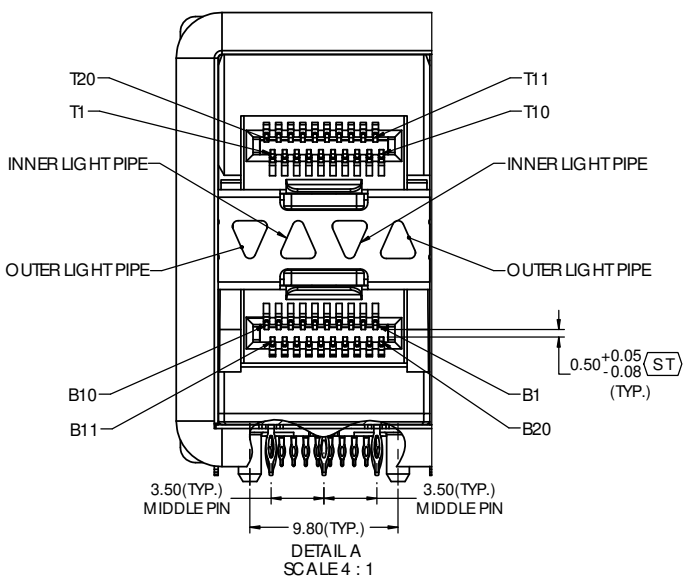

UNLESS SPECIFIED OTHERWISE	DRAWN	P. OU	FEB10/14
DIMENSIONS ARE IN MILLIMETERS	CHECKED	J. SI	FEB 12/14
REFERENCE IN PARENTHESES	M.E. APP'D		
GENERAL TOLERANCES	Q.A. APP'D		
1 DECIMAL PLACE ±0.25	DWG APP'D	J. SI	FEB 12/14
2 DECIMAL PLACE ±0.15	MATERIAL AND FINISH	SEE NOTES	
3 DECIMAL PLACE N/A	REF.	ECN Exxxxx	
ANGULAR DEGREES ±1°	THIRD ANGLE PROJECTION	DO NOT SCALE DRAWING	
ENG. REL. NO.			

**Amphenol High Speed Interconnects**  
A Division of Amphenol Corp. [www.amphenolcanada.com](http://www.amphenolcanada.com)

**2X2 SFP ULTRAPORT WITH LIGHT PIPE OPTIONS AND EMI GASKET**

DWG. NO. **P-UE86-3G2420-X0361** REV **C**

CODE ID NO. 03554 DWG SIZE: C SCALE: 3:1 SHEET 2 OF 4

THIS DOCUMENT CONTAINS PROPRIETARY INFORMATION AND SUCH INFORMATION MAY NOT BE DISCLOSED TO OTHERS FOR ANY PURPOSE OR USED FOR MANUFACTURING PURPOSES WITHOUT WRITTEN PERMISSION FROM AMPHENOL CANADA CORP.

REVISIONS				
REV.	ECN	DESCRIPTION	DATE	APPROVED
A		INITIAL RELEASE	10/02/2014	J.SI
B		UPDATE PLATING OPTIONS	JUN 25/14	J.SI
C		UPDATE NOTES	AUG 14/15	J.SI

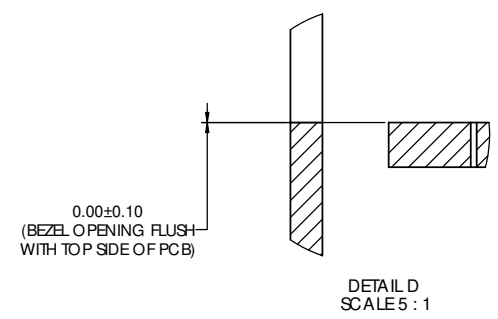
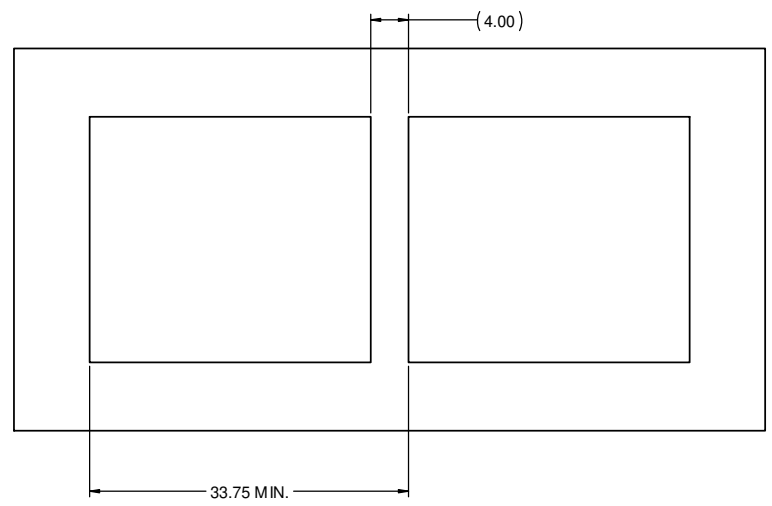
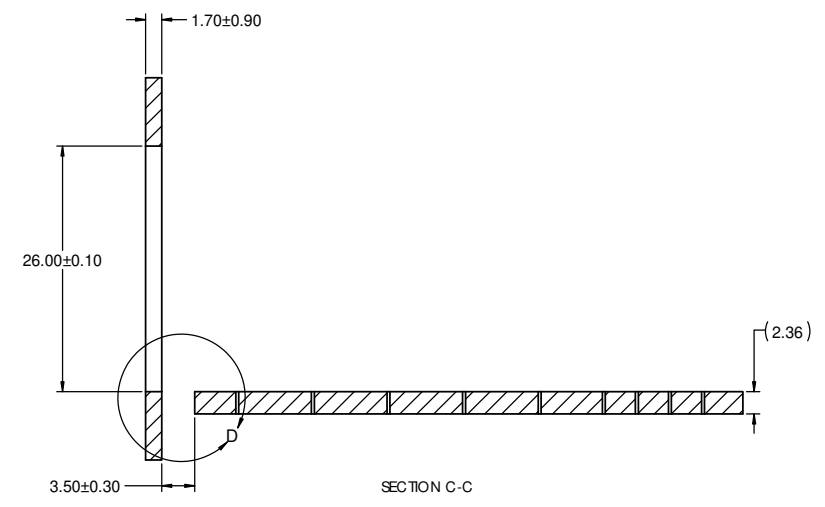
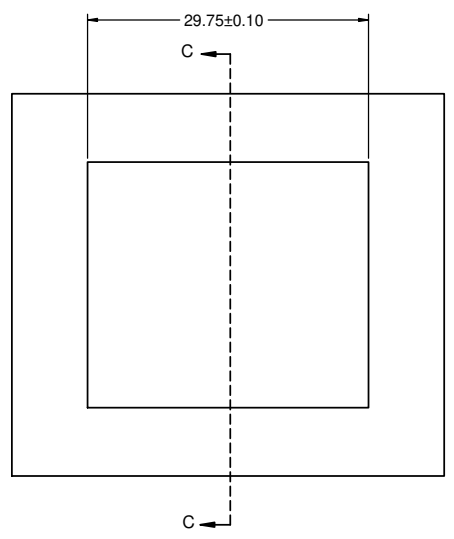

THIS DOCUMENT CONTAINS PROPRIETARY INFORMATION AND SUCH INFORMATION MAY NOT BE DISCLOSED TO OTHERS FOR ANY PURPOSE OR USED FOR MANUFACTURING PURPOSES WITHOUT WRITTEN PERMISSION FROM AMPHENOL CANADA CORP.

UNLESS SPECIFIED OTHERWISE	DRAWN	P. OU	FEB10/14
DIMENSIONS ARE IN MILLIMETERS	CHECKED	J. SI	FEB 12/14
REFERENCE IN PARENTHESES	M.E. APP'D		
GENERAL TOLERANCES	Q.A. APP'D		
1 DECIMAL PLACE ±0.25	DWG APP'D	J. SI	FEB 12/14
2 DECIMAL PLACE ±0.15	MATERIAL AND FINISH	SEE NOTES	
3 DECIMAL PLACE N/A	REF.	ECN Exxxxx	
ANGULAR DEGREES ±1°	THIRD ANGLE PROJECTION	DO NOT SCALE DRAWING	
ENG. REL. NO.			

**Amphenol High Speed Interconnects**  
 A Division of Amphenol Corp. [www.amphenolcanada.com](http://www.amphenolcanada.com)

**2X2 SFP ULTRAPORT WITH LIGHT PIPE OPTIONS AND EMI GASKET**

DWG. NO. **P-UE86-3G2420-X0361** REV **C**

CODE ID NO. 03554 | DWG SIZE: C | SCALE: 2.5:1 | SHEET 3 OF 4

REVISIONS				
REV.	ECN	DESCRIPTION	DATE	APPROVED
A		INITIAL RELEASE	10/02/2014	J.S
B		UPDATE PLATING OPTIONS	JUN 25/14	J.S
C		UPDATE NOTES	AUG 14/15	J.S

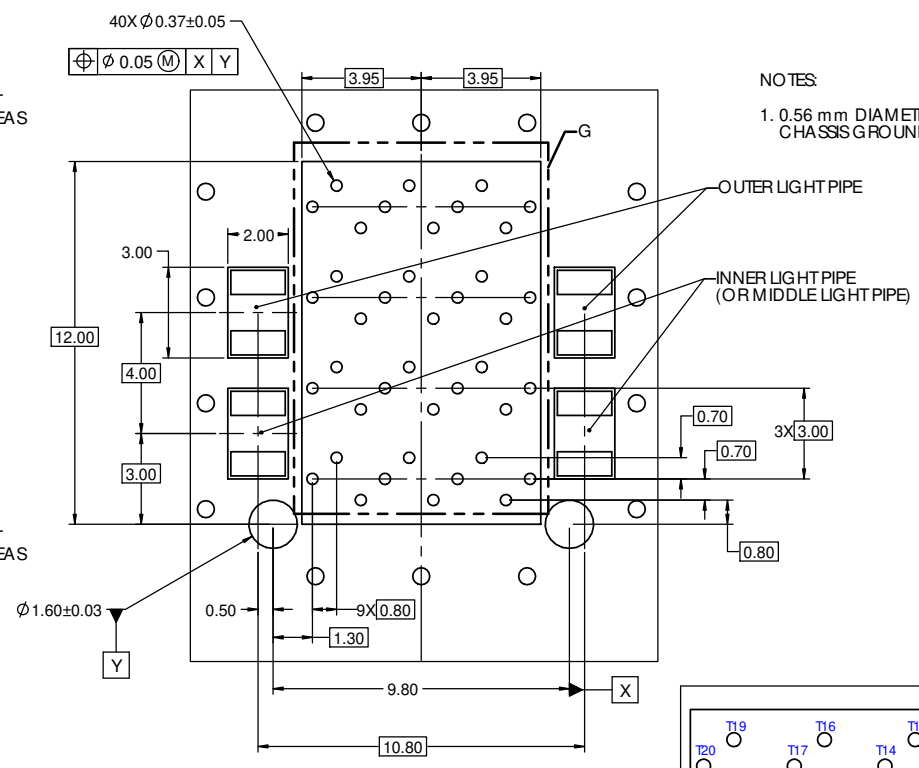
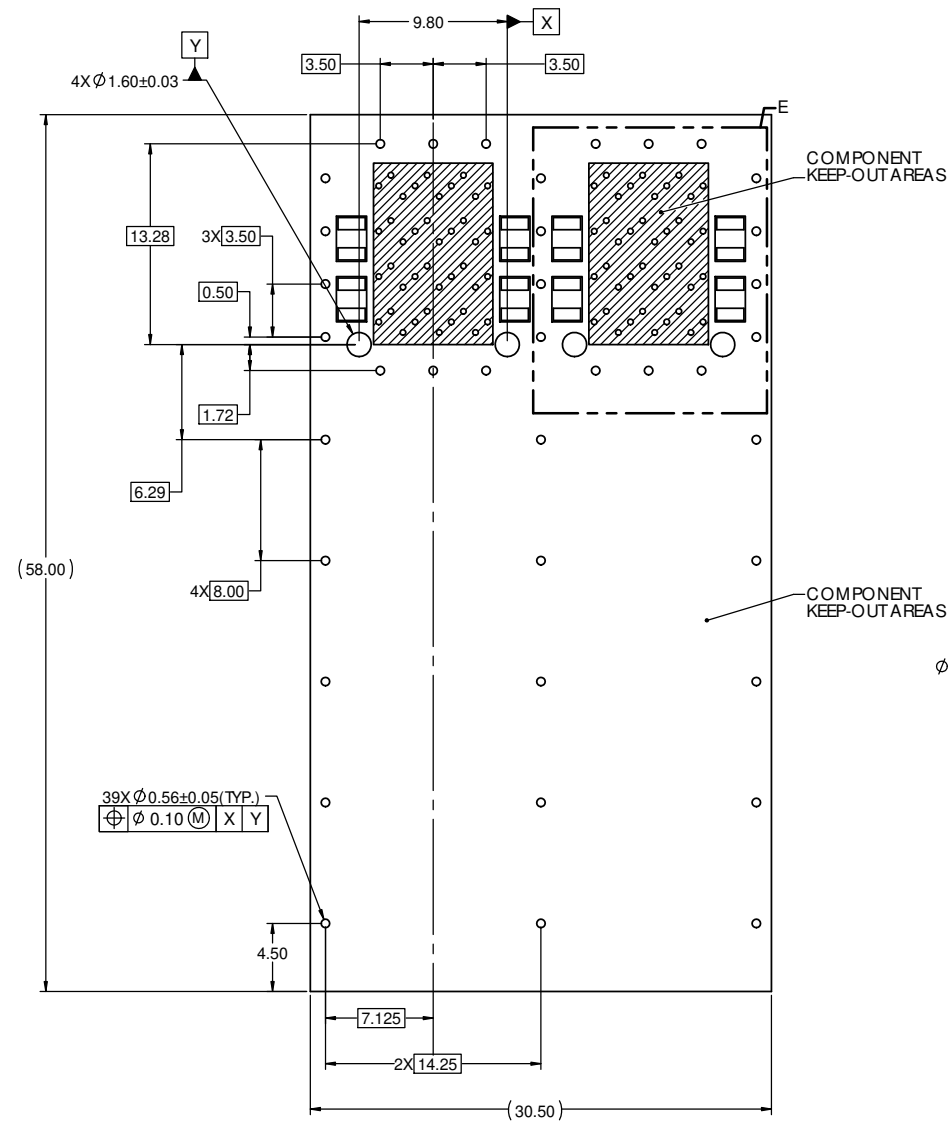

NOTES:  
1. 0.56 mm DIAMETER HOLES ARE CHASSIS GROUND (39 HOLES).

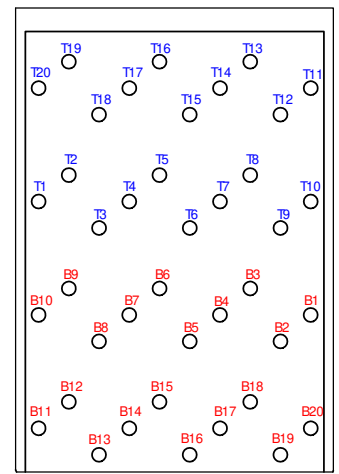

THIS DOCUMENT CONTAINS PROPRIETARY INFORMATION AND SUCH INFORMATION MAY NOT BE DISCLOSED TO OTHERS FOR ANY PURPOSE OR USED FOR MANUFACTURING PURPOSES WITHOUT WRITTEN PERMISSION FROM AMPHENOL CANADA CORP.

UNLESS SPECIFIED OTHERWISE	DRAWN	P. OU	FEB10/14
DIMENSIONS ARE IN MILLIMETERS	CHECKED	J. SI	FEB 12/14
REFERENCE IN PARENTHESES	M.E. APP'D		
GENERAL TOLERANCES	Q.A. APP'D		
1 DECIMAL PLACE $\pm 0.25$	DWG APP'D	J. SI	FEB 12/14
2 DECIMAL PLACE $\pm 0.15$	MATERIAL AND FINISH	SEE NOTES	
3 DECIMAL PLACE N/A	REF.	ECN Exxxxx	
ANGULAR DEGREES $\pm 1^\circ$	THIRD ANGLE PROJECTION	DO NOT SCALE DRAWING	
ENG. REL. NO.			

**Amphenol High Speed Interconnects**  
A Division of Amphenol Corp. [www.amphenolcanada.com](http://www.amphenolcanada.com)

**2X2 SFP ULTRAPORT WITH LIGHT PIPE OPTIONS AND EMI GASKET**

DWG. NO. **P-UE86-3G2420-X0361** REV **C**

CODE ID NO. 03554 DWG SIZE: C SCALE: 4:1 SHEET 4 OF 4