

DESCRIPTION

Demonstration circuit 1100 is an isolated Telecom DC/DC converter featuring the LTC3803ES6-3 constant frequency current mode flyback controller. The DC1100 converts 18V to 72V input into 3.3V output and provides 3A of output current. The 300kHz constant frequency operation is maintained down to light loads which reduces low frequency noise that occurs when power converters operate in pulse skipping mode. The converter provides high output voltage accuracy (typically $\pm 2\%$) over wide load range with no minimum load requirement.

The DC1100 can easily be modified to generate different output voltages. Higher output voltages and currents can be achieved by changing the MOSFET, transformer and output capacitors. Please consult LTC factory for details.

The DC1100 has a small circuit footprint. It is a high performance and cost effective solution for Telecom, Automotive and Power Over Ethernet applications.

Design files for this circuit board are available. Please call the LTC factory.

LTC is a trademark of Linear Technology Corporation

Table 1. Performance Summary

PARAMETER	CONDITION	VALUE
Minimum Input Voltage		18V
Maximum Input Voltage		72V
V_{OUT}	$V_{IN} = 18V \text{ to } 72V,$ $I_{OUT} = 0A \text{ to } 3A$	3.3V $\pm 3\%$
Typical Output Ripple V_{OUT}	$V_{IN} = 18V \text{ to } 72V,$ $I_{OUT} = 0A \text{ to } 3A$	50mV _{p-p}
Nominal Switching Frequency		300kHz

QUICK START PROCEDURE

Demonstration circuit 1100 is easy to set up to evaluate the performance of the LTC3803ES6-3. For proper measurement equipment setup refer to Figure 1 and follow the procedure below:

NOTE: When measuring the input or output voltage ripple, care must be taken to minimize the length of the oscilloscope probe ground lead. Measure the input or output voltage ripple by connecting the probe tip directly across the VIN or VOUT and GND terminals as shown in Figure 2.

1. With power off, connect the input power supply to +Vin and GND.
2. Turn the input power source on and slowly increase the input voltage. Be careful not to exceed 72V.

NOTE: Make sure that the input voltage V_{in} does not exceed 72V. If higher operating voltage is required, power components with higher voltage ratings should be used.

3. Check for proper output voltage of 3.3V.

QUICK START GUIDE FOR DEMONSTRATION CIRCUIT 1100

ISOLATED FLYBACK DC/DC CONVERTER

If there is no output, temporarily disconnect the load to make sure that the load is not set too high.

- Once the proper output voltage is established, adjust the load within the 3A range and observe the output voltage regulation, ripple voltage, efficiency and other parameters

EFFICIENCY

The efficiency of DC1100 is shown in Figure 3. The efficiency is relatively high for a non synchronous flyback converter. To achieve the highest possible efficiency from such a converter, the power components must be selected to find the optimal compromise between switching and conduction losses.

Note that the efficiency will be higher for outputs that are higher than the 3.3V output.

PRE-REGULATOR Q1

The pre-regulator circuit Q1, D2 and R1 is used to provide quick circuit startup and to provide power during a long soft start sequence controlled by U2 (Figure 4). If hysteretic startup is used by eliminating Q1 circuit the power for U1 has to be provided by C3 and R2 during soft start period controlled by C7 and U2. In any case, the value of C3 will have to be much higher than 0.1uF. Also, the size of C3 will depend on the size of Q2 since the gate drive power for Q2 comes from C3 and R2 during startup.

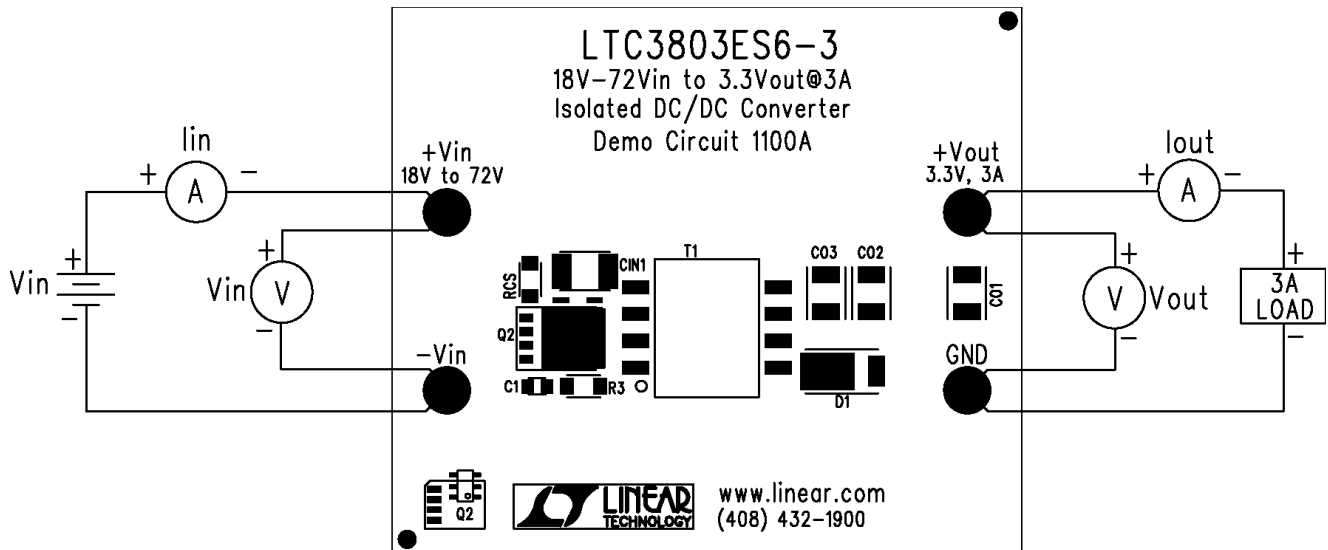

Figure 1. Proper Measurement Equipment Setup

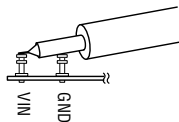

Figure 2. Measuring Input or Output Ripple

QUICK START GUIDE FOR DEMONSTRATION CIRCUIT 1100

ISOLATED FLYBACK DC/DC CONVERTER

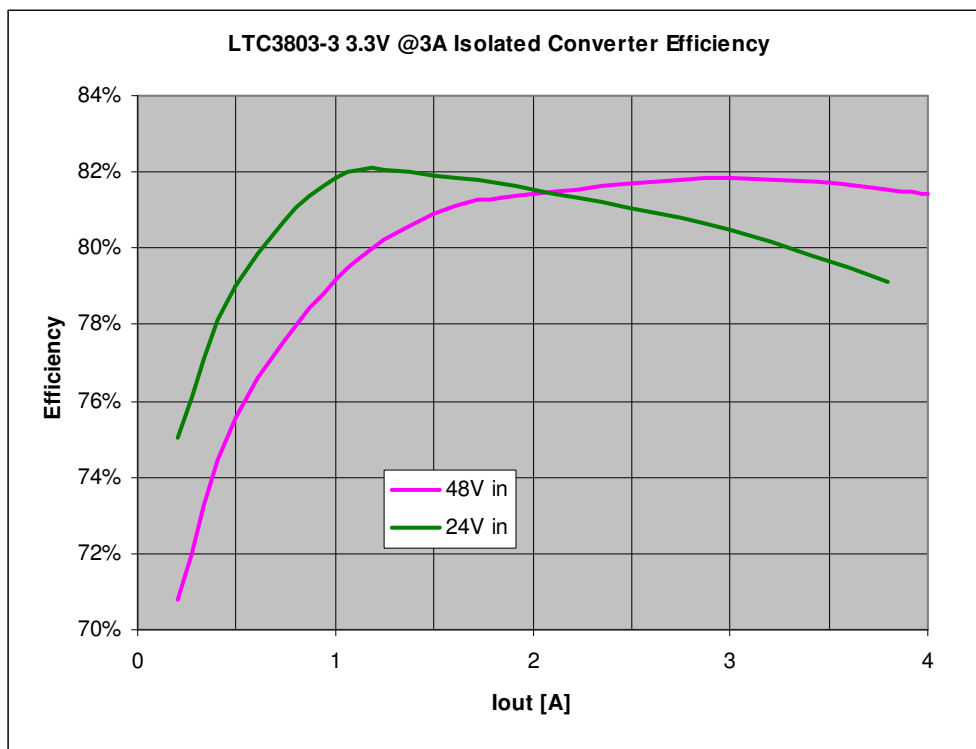

Figure 3. High efficiency of DC1100 power converter is possible thanks to optimal selection of power components.

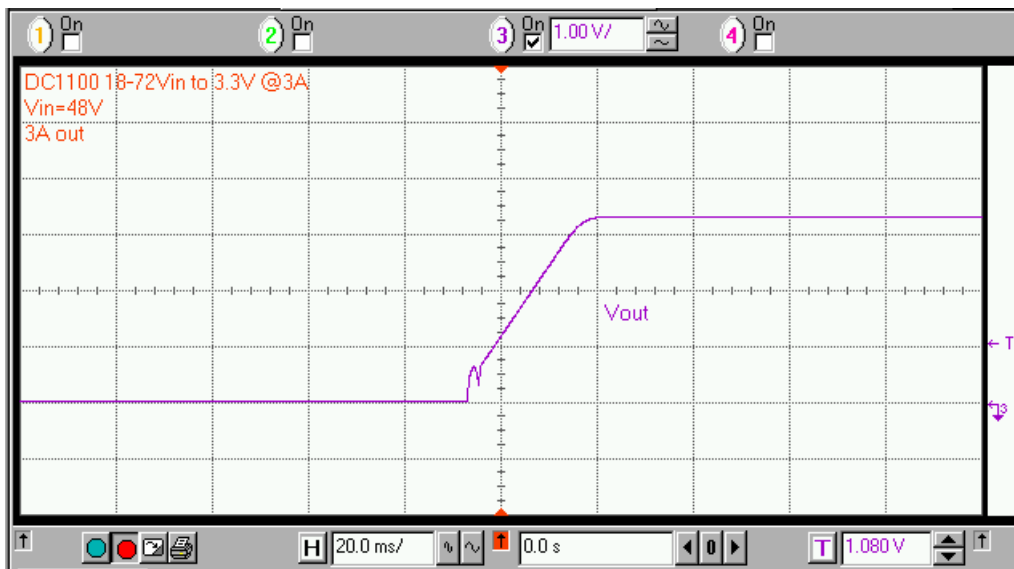
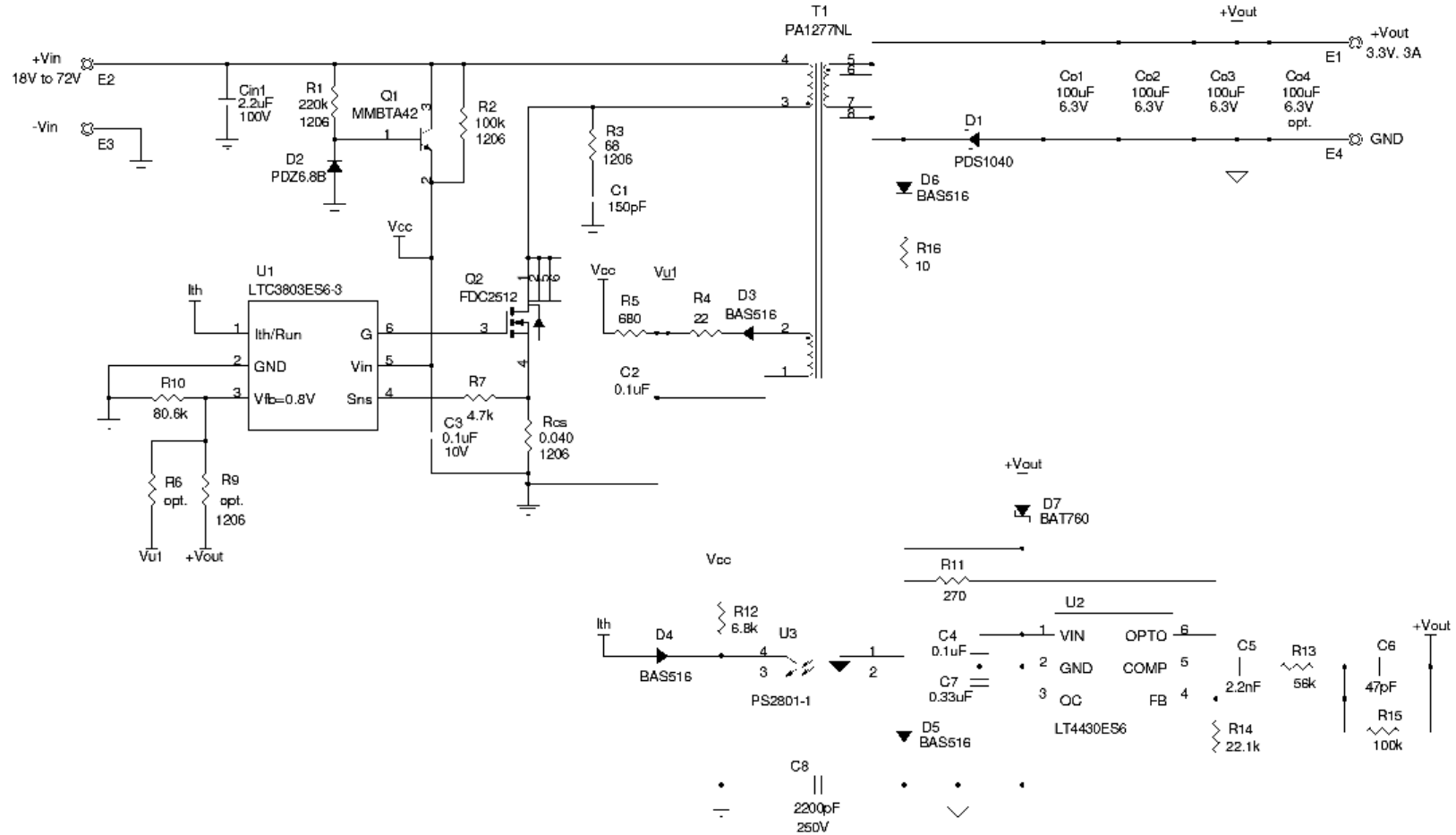

Figure 4. The soft start is controlled by the opto-coupler driver LT4430 which produces an output voltage ramp without overshoot.

QUICK START GUIDE FOR DEMONSTRATION CIRCUIT 1100

ISOLATED FLYBACK DC/DC CONVERTER



CUSTOMER NOTICE

LINEAR TECHNOLOGY HAS MADE A BEST EFFORT TO DESIGN A CIRCUIT THAT MEETS CUSTOMER-SUPPLIED SPECIFICATIONS; HOWEVER, IT REMAINS THE CUSTOMER'S RESPONSIBILITY TO VERIFY PROPER AND RELIABLE OPERATION IN THE ACTUAL APPLICATION. COMPONENT SUBSTITUTION AND PRINTED CIRCUIT BOARD LAYOUT MAY SIGNIFICANTLY AFFECT CIRCUIT PERFORMANCE OR RELIABILITY. CONTACT LINEAR TECHNOLOGY APPLICATIONS ENGINEERING FOR ASSISTANCE. THIS CIRCUIT IS PROPRIETARY TO LINEAR TECHNOLOGY AND SUPPLIED FOR USE WITH LINEAR TECHNOLOGY PARTS.

CONTRACT NO.

APPROVALS	DATE	TITLE
DRWEN June Wu	4/27/06	
CHKD ()		
APPROV ()		
ENGINEER Goran Perovic	4/27/06	
DESIGNER		



Local Marketing Dept
Folsom, CA 95685
Phone: (408)432-1900
Fax: (408)432-2947

LTC3803ES6-3
18V-72Vin to 3.3Vout@3A Isolated DC/DC Converter

SIZE	CAGE CODE	DWG NO	REV
		DC1100A	A
		SHEET 1	OF 1

Issued: November 07, 2000 SCALE:

FILENAME: