



# **ISM43341-L77 EVB**

## Wi-Fi, Bluetooth and NFC Radio Only Evaluation Board User's Manual



## 1 General Description

The Inventek ISM43341-L77 is a single-chip quad-radio device that provides the highest level of integration for a wireless system, with integrated dual band (2.4 GHz/ 5 GHz) IEEE 802.11 a/b/g/n /baseband/radio. In addition to Wi-Fi, the chip also provides Bluetooth 4.0, and a low power NFC controller.

The ISM43341-L77-EVB is a radio only solution that is ideal for integration with a single board computer running Linux. The evaluation board plugs directly into an SDIO/MicroSD slot and can be used with an ARM or x86 host processor running Linux Kernel 3.10 or later. Inventek Systems provides Wi-Fi and Bluetooth drivers for several different platforms.

### **Hardware Features:**

- Uses Broadcom BCM43341/0 802.11 a/b/g/n Wi-Fi Radio
- Bluetooth 4.0 including BLE support.
- Near Field Communication (NFC option)
- 2.4 & 5 GHz chip antenna for Wi-Fi and Bluetooth .
  - U.FL Connector for external antenna
- Host interfaces:
  - SDIO: WiFi
  - UART: Bluetooth
  - I2C/UART/SPI: NFC
- Input Power: 3.3 V
- Dual port FTDI for NFC and Bluetooth HCI over USB
- FCC and CE approval

## 2 Part Number Detail Description

ISM43341-L77-EVB	Wi-Fi, Bluetooth, and NFC	On board Antenna
ISM43341-L77-EVB	Wi-Fi, Bluetooth, NFC	On board Antenna

## 3 Additional Documentation

- ISM43340/1-L77 Functional Specification
- ISM4334x-L77\_EVB\_iMX6\_Quick\_Start\_Guide\_R3\_AN20093

## 4 ISM4334x-L77-EVB Architecture

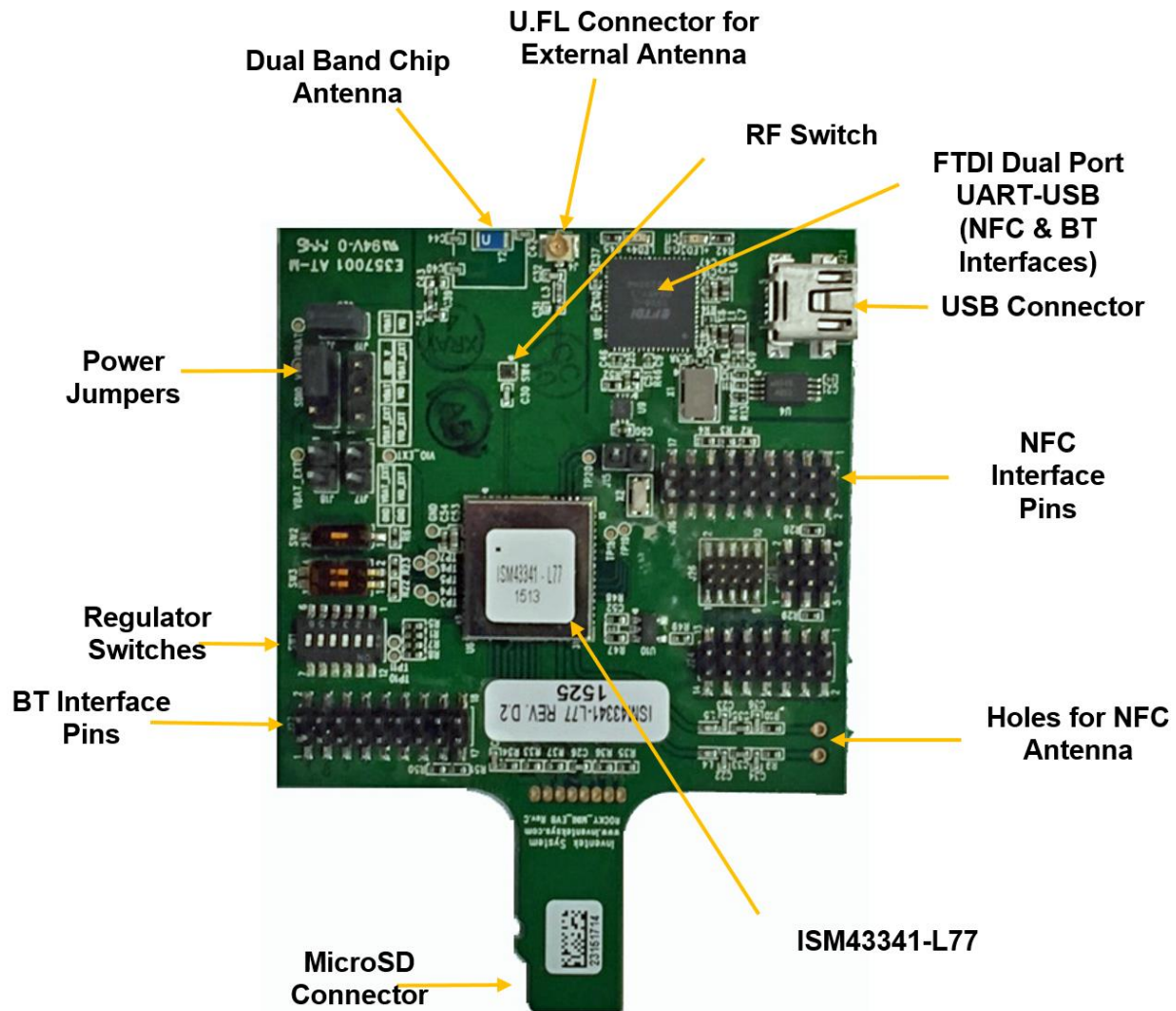

### 4.1 Powering the Board

Two power connections are necessary to power the module:

- VBAT
- VIO

VBAT must be 3.3V, while VIO can range from 1.8 V to 3.3V. When using the ISM43341-L77-EVB, Inventek recommends connecting VIO and VBAT.

### 4.1.1 Power Through SDIO

- Place a jumper on J25, to connect VBAT and VIO.
- Place a jumper between pins 2 and 3 on J20, to tie VBAT to SDIO voltage supply.

### 4.1.2 External Power

- Place a jumper on J25, to connect VBAT and VIO.
- Connect an external 3.3V Supply. Pin 2 on J20, is power. Pin 2 on J18 is GND.

## 5 Schematic

### 5.1 Radio, Power, & RF

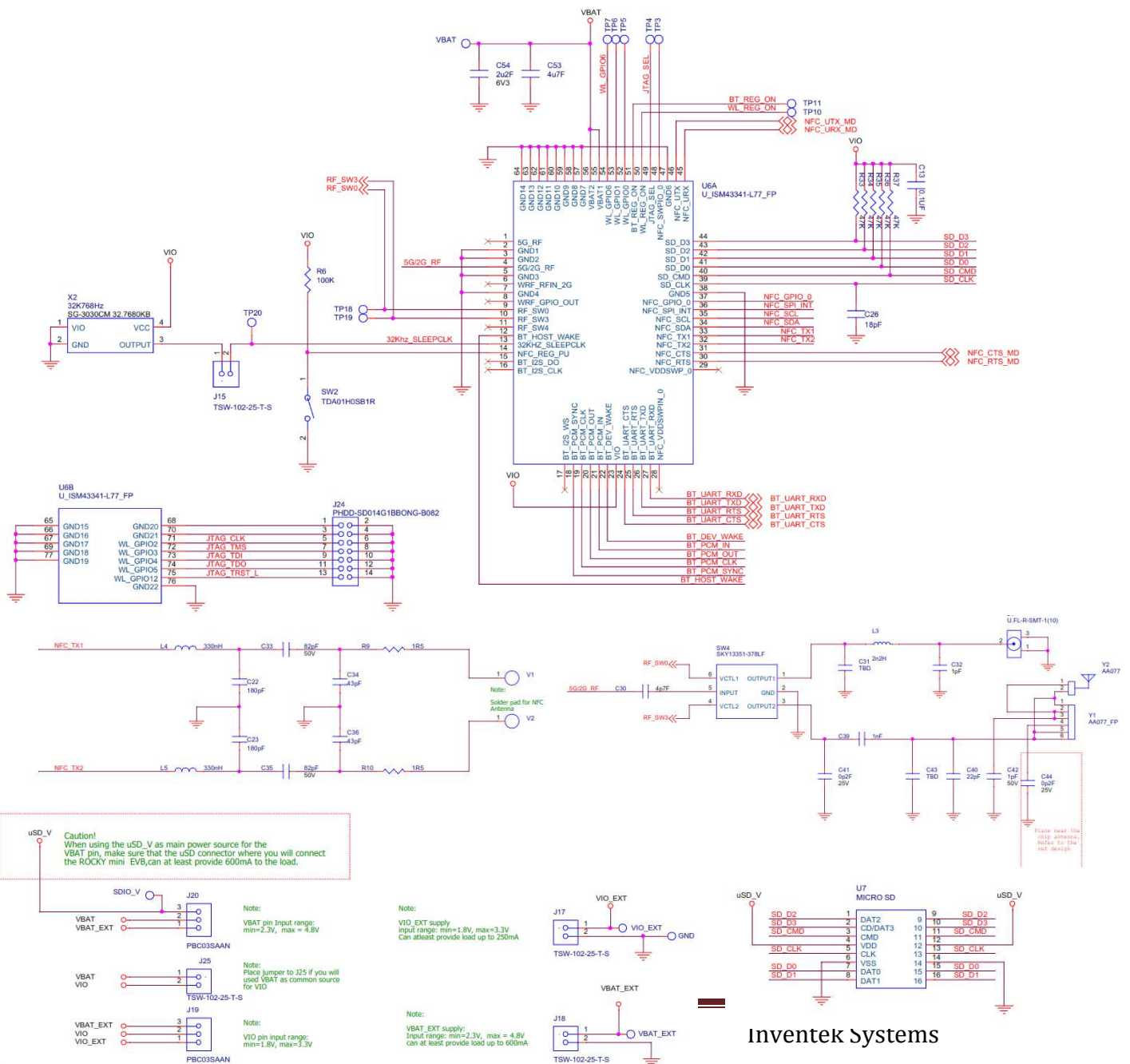

## 5.2 Host Interface Headers, Regulator and Config Switches

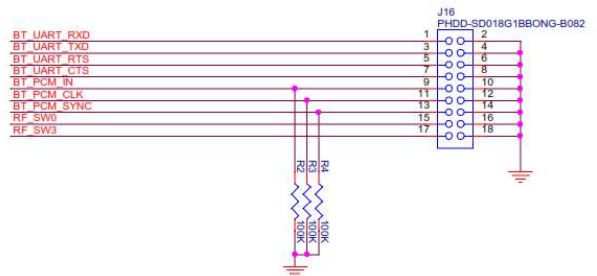
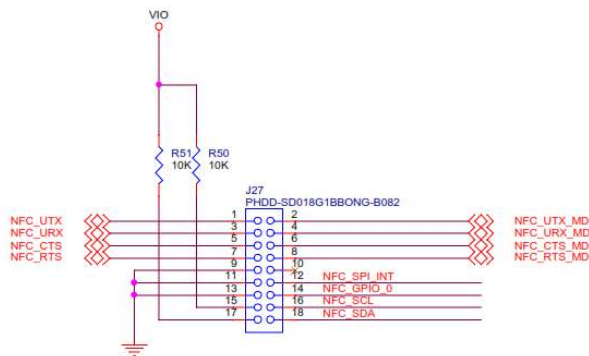
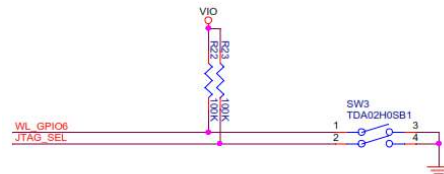
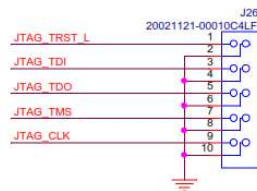
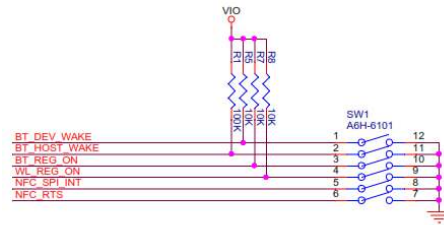
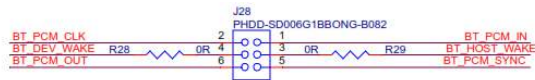

## 5.3 FTDI & NFC EEPROM

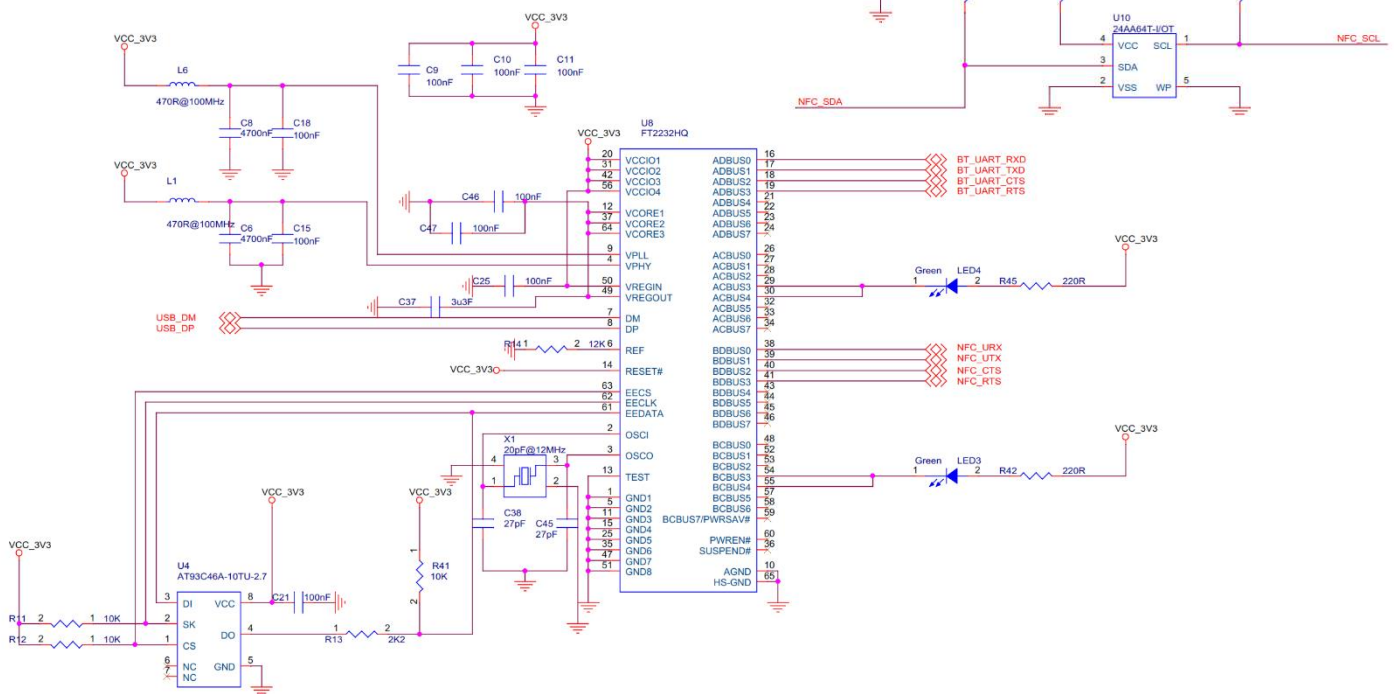

## 6 Revision Control

Document : ISM4334xC-Shield	Wi-Fi module
External Release	DOC-DS-20095

Date	Author	Revision	Comment
2/24/2016	KMT	1.0	Preliminary Release

--	--	--	--

--	--	--	--

## 7 CONTACT INFORMATION

Inventek Systems  
2 Republic Road  
Billerica MA, 01862  
Tel: 978-667-1962  
[Sales@inventeksys.com](mailto:Sales@inventeksys.com)

[www.inventeksys.com](http://www.inventeksys.com)

Inventek Systems reserves the right to make changes without further notice to any products or data herein to improve reliability, function, or design. The information contained within is believed to be accurate and reliable. However Inventek Systems does not assume any liability arising out of the application or use of this information, nor the application or use of any product or circuit described herein, neither does it convey any license under its patent rights nor the rights of others.