

MATERIAL NO.	ENGINEERING NO.	LENGTH
1303040401	1303040401	0.33M + 44.5mm -0 [1.08' +1.75' -0]
1303040403	1303040403	1.0M +55.6mm -0 [3.28' +2.19' -0]
1303040404	1303040404	2.0M +88.9mm -0 [6.56' +3.50' -0]
1303040405	1303040405	3.0M +88.9mm -0 [9.84' +3.50' -0]
1303040406	1303040406	4.0M +165.1mm -0 [13.12' +6.50' -0]
1303040407	1303040407	5.0M +165.1mm -0 [16.40' +6.50' -0]
1303040412	1303040412	10.0M +317.5mm -0 [32.81' +12.50' -0]
1303040421	1303040421	0.7M + 44.5mm -0 [2.30' +1.75' -0]
1303040422	1303040422	1.4M + 55.6mm -0 [4.59' +2.19' -0]

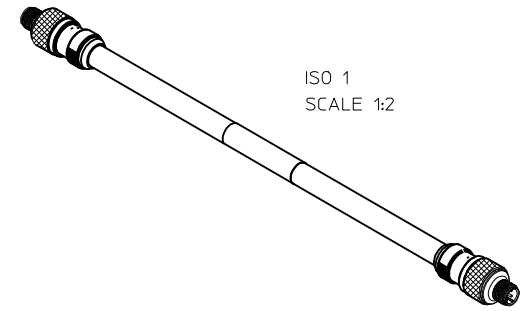

ISO 1
SCALE 1:2

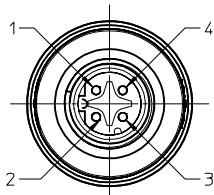

MALE FACE VIEW
SCALE 2:1

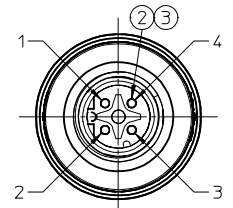
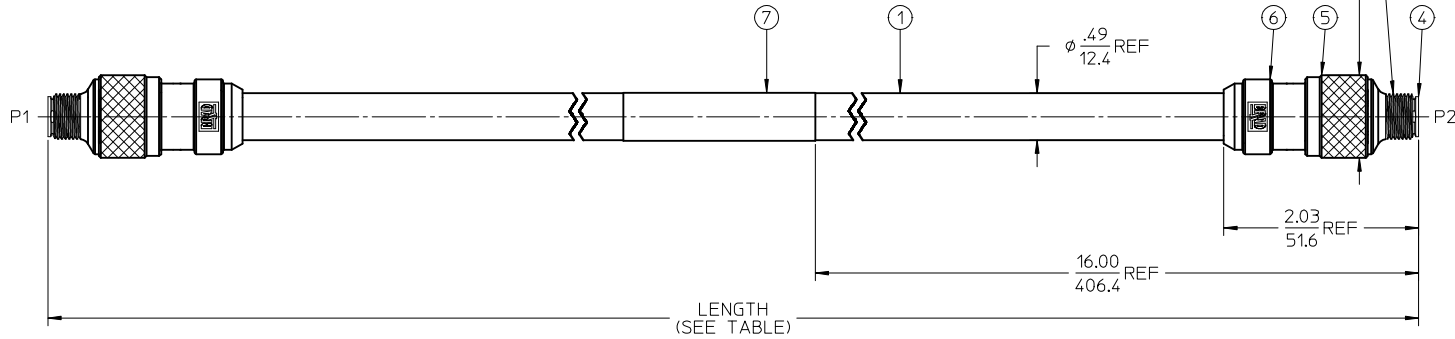

MALE FACE VIEW
SCALE 2:1

NOTES:

1. COMPLIES WITH SAE J2839
2. ASSEMBLY IS FULLY SHIELDED
3. ELECTRICAL RATINGS:
VOLTAGE 30V DC
CURRENT: 1.5AMPS MAX
4. COUPLING NUT TORQUE: HAND TIGHT
5. MATERIALS: SEE TABLE
6. FINISHES: SEE TABLE
7. ASSEMBLY IS RoHS COMPLIANT

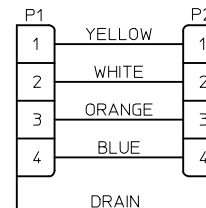

COUPLER WIRING DIAGRAM
(SEE NOTE 2)

ITEM	QTY	DESCRIPTION	MATERIAL	FINISH
7	1	LABEL	PLASTIC FILM	YELLOW
6	2	OVERMOLD	PBT	GREY
5	2	MALE COUPLING NUT, M12	STAINLESS STEEL	PASSIVATED
4	2	MALE HOUSING, D-CODE	ZINC DIE-CAST	CHROME
3	2	MALE INSULATOR, 4C	PBT	BLACK
2	8	MALE CONTACT PIN, 18AWG	Cu ALLOY	GOLD PLATED
1	1	CABLE, 18AWG, 4/C, SHIELDED	XRAD XLE JACKET	SEE WIRE DIAGRAM

ADD 1303040406	2014/11/26	QUALITY SYMBOLS
EC NO: JFG2015-1018	DRWINRSTONE	▼=0
CHKD: B ARDEN	2014/12/02	▽=0
APPR: J MURPHY	2014/12/02	
REV	DESCRIPTION	

GENERAL TOLERANCES (UNLESS SPECIFIED)	
mm	INCH
4 PLACES ± ---	± ---
3 PLACES ± ---	± .005
2 PLACES ± 0.13	± .010
1 PLACE ± 0.25	± .020
ANGULAR ± 1/1°	

DIMENSION STYLE	
IN/MM	
DRAWN BY	DATE
LHARTMANN	2011/01/17
CHECKED BY	DATE
VOU	2011/02/22
APPROVED BY	DATE
DTITUS	2012/05/10

SCALE	DESIGN UNITS	THIRD ANGLE PROJECTION
1:1	INCH	☉
TITLE		
M12 HD 100LB CORDSET 4P M/ME ST/ST E-NET #18/4 BLACK XLPE CBL		
MATERIAL NO.		SHEET NO.
SEE TABLE		1 OF 1
DOCUMENT NO.		
SD-130304-005		
THIS DRAWING CONTAINS INFORMATION THAT IS PROPRIETARY TO MOLEX INCORPORATED AND SHOULD NOT BE USED WITHOUT WRITTEN PERMISSION		