

PART NAME: KNOB SCALE: 1:1 DATE: 7/11/00 DR. BY JAM

THIS DRAWING IS THE PROPERTY OF DAVIES MOLDING COMPANY, IS SUBMITTED SOLELY AS A DESIGN OR ENGINEERING PROJECT. WE ACCEPT NO RESPONSIBILITY WHATSOEVER FOR THE PRACTICAL APPLICATION OF THE PIECES MADE TO THIS DESIGN.



DESIGNERS & MANUFACTURERS OF KNOBS, HANDLES, CASES & CUSTOM PLASTIC COMPONENTS

P/N 1920AU

BASE PART 1920-04

SPRING I1216

(A)

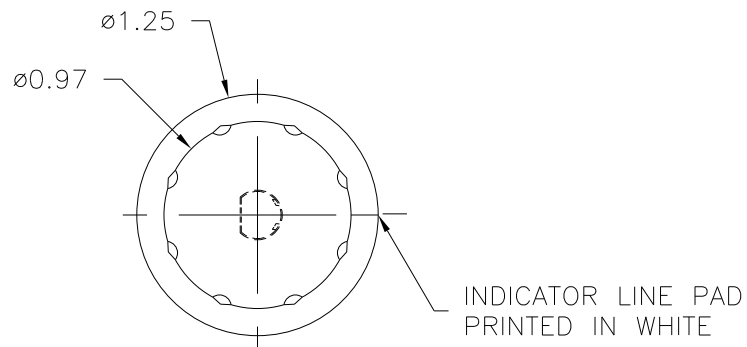

NOTE : AFTER MOLDING PROCESS SPRING I1216 MUST BE INSTALLED IN FINISHING DEPT. FOR COMPLETED PART AS 1920AU

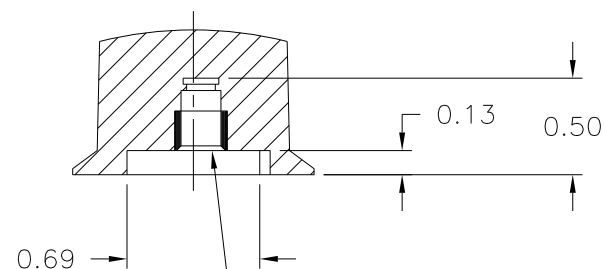
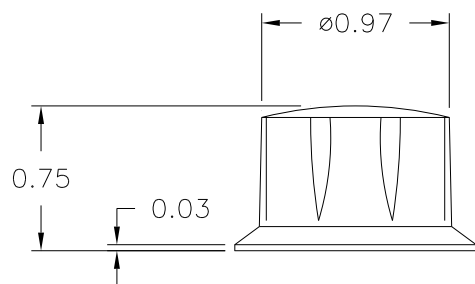

SPRING MTG. TO FIT 1/4 DIA. SHAFT FLATTED TO 0.218

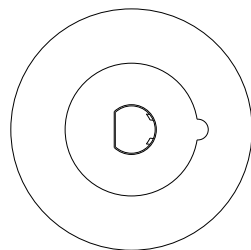

MATERIAL: G.P. PHENOLIC (B11)
COLOR: BLACK

TOLERANCES: UNLESS OTHERWISE SPECIFIED	DO NOT SCALE DRAWING	A	ADDED BASE PART	JAM	4/2/14
		-	WAS SK1920-02	ST	7/18/2000
DECIMALS: X.XXX ± .005 X.XX ± .015	MM: X.XX ± 0.15MM X.X ± 0.4MM	-	DRAWING CORRECTED	TS	7/14/2000
		-	ORIGINAL DRAWN BY	HD	11/1/93
FRACTIONS ± 1/64	ANG. ± 1°	CHANGES			