

Photologic® Dual Channel Encoder OPBA301, OPBA303

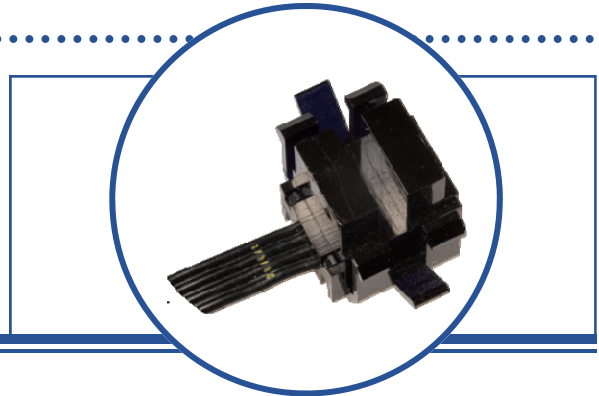

Features:

- Dual channel outputs for Quadrature output
- Open collector inverter outputs
- 0.010" (0.254 mm) sensor apertures for high resolution
- Snap mount



Description:

The **OPBA301** and **OPBA303** device consists of an infrared emitting diode and a monolithic integrated circuit which incorporates two independent photodiodes, linear amplifiers, Schmitt trigger circuits and output transistors. The **OPBA301** features a dual TTL output that is compatible with TTL/LSTTL and can drive 8 TTL loads. The **OPBA303** has a 10K Ω pull-up output with EMI protection on each channel.

Applications include linear and rotary encoders with high resolution provided by internal 0.010" (0.254 mm) apertures located in front of the Photologic® sensor on 0.040" (1.02 mm) center line spacing.

Custom electrical design, wire length and connectors are available. Contact your local representative or OPTEK for more information.

Applications:

- Mechanical switch replacement
- Speed and direction indication
- Mechanical limit indication
- Rotary encoders
- Edge sensing
- Sliding door automotive and liftgate applications

Ordering Information					
Part Number	LED Peak Wavelength	Sensor Output	Slot Width / Depth	Aperture Emitter/Sensor	Wire Length
OPBA301	890 nm	Dual TTL	0.200" / 0.350"	0.05" / 0.01"	24" 22 AWG Flat
OPBA303		10K Pull-Up			

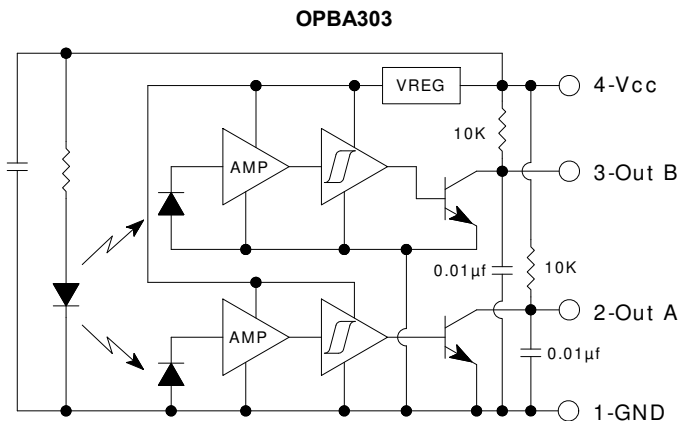
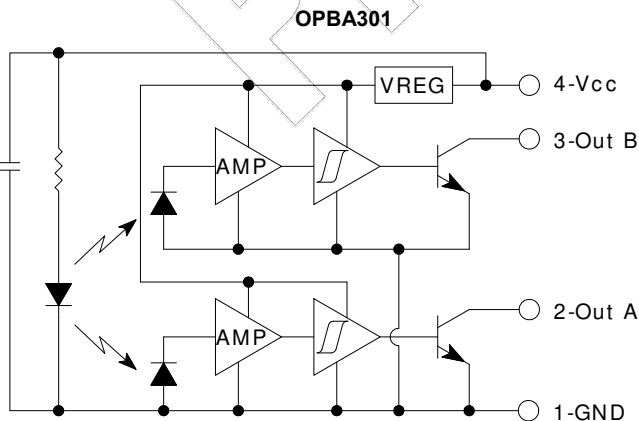

OPTEK Technology is TS 16949:2002 certified, any changes will be consistent with TS 16949:2002 procedures.

OPBA301, OPBA303

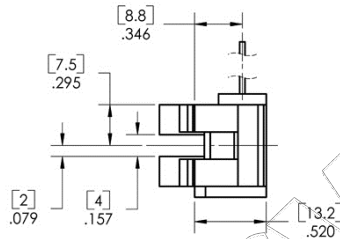
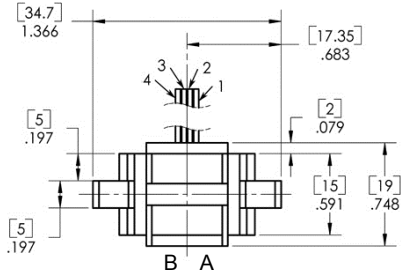

Pin #	Description
1	Output-A
2	Output-B
3	V _{CC}
4	Ground

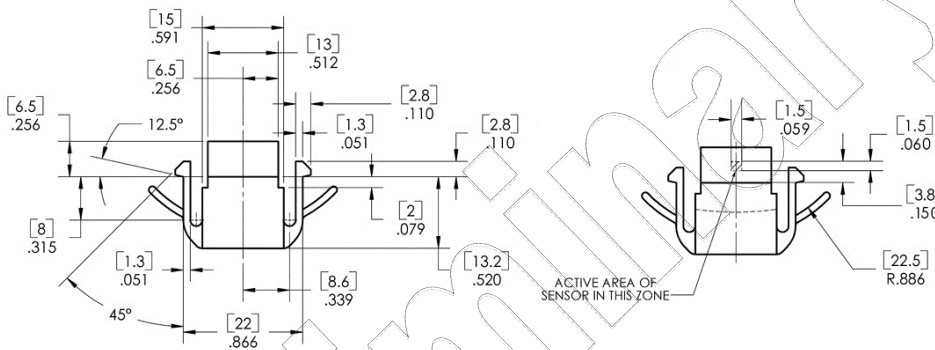

CONTAINS POLYSULFONE
 To avoid stress cracking, we suggest using ND Industries' **Vibra-Tite** for thread-locking. **Vibra-Tite** evaporates fast without causing structural failure in OPTEK's molded plastics.

Absolute Maximum Ratings (T_A = 25° C unless otherwise noted)

Storage & Operating Temperature Range	-40°C to +85° C
---------------------------------------	-----------------

Input Diode

Forward DC Current	50 mA
Reverse DC Voltage	2.0 V
Power Dissipation ⁽¹⁾	100 mW

Output Photologic®

Supply Voltage, V _{CC}	5.5 V
Voltage at Output OPBA301 OPBA303	18 V 5.5V
Power Dissipation ⁽²⁾	200 mW
Sinking Output Current	40 mA

DIMENSIONS ARE IN: [MILLIMETERS]
 INCHES

OPTEK Technology is TS 16949:2002 certified, any changes will be consistent with TS 16949:2002 procedures.

Electrical Characteristics ($T_A = 25^\circ\text{C}$ unless otherwise noted)

SYMBOL	PARAMETER	MIN	TYP	MAX	UNITS	TEST CONDITIONS
Input Diode						
V_{CC}	Supply Voltage	4.5	-	5.5	V	
Output Photologic® Sensor						
I_{CCL}	Supply Current Both Outputs Low (both photodiodes irradiated)	-	25.5	29	mA	Unblocked condition (no load on output)
I_{CCH}	Supply Current Both Outputs High (both photodiodes shaded)	-	20.5	23	mA	Blocked condition (no load on output)
I_{CCM}	Supply Current Mixed Output States (one high, one low)	-	23	-	mA	1 blocked condition 1 unblocked condition
I_{OH}	High Level Output Current	-	1	30	μA	$V_{OH} = 16\text{ V}$ (blocked condition)
V_{OL}	Low Level Output Voltage	-	0.21	0.40	V	$I_{OL} = 12.8\text{ mA}$ (unblocked condition)
t_{PHL}, t_{PLH}	Propagation Delay Output High to Low Output Low to High	-	2 10	-	μs μs	$V_{CC} = 5\text{ V}$, $R_L = 360\ \Omega$, $f = 10\text{ kHz}$, $DC = 50\%$
t_r, t_f	Output Rise Time Output Fall Time	-	20 5	-	ns ns	$R_L = 360\ \Omega$

Performance Curves

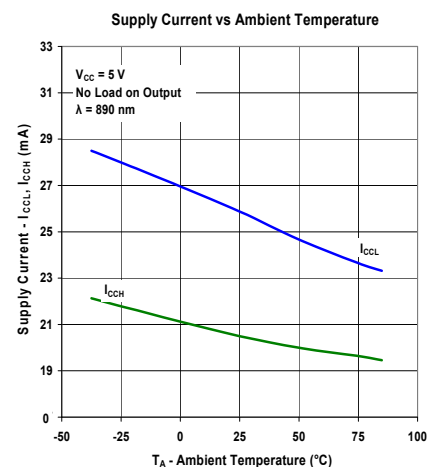
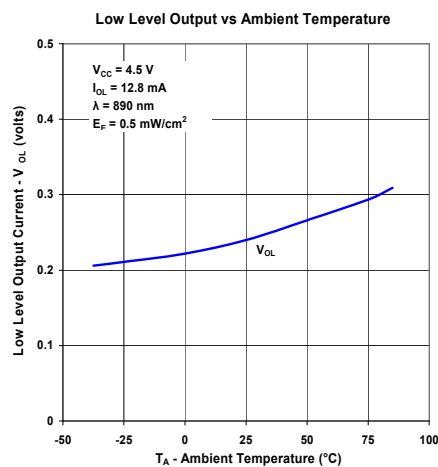
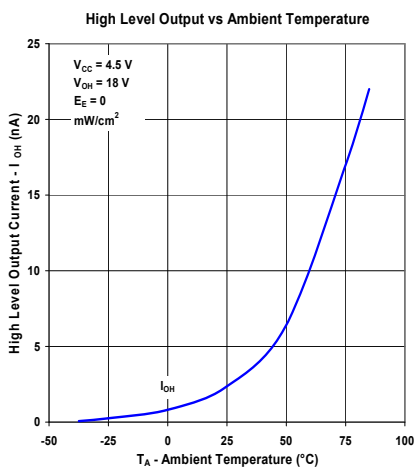

OPTEK Technology is TS 16949:2002 certified, any changes will be consistent with TS 16949:2002 procedures.

Performance Curves

Rise and Fall Time vs Ambient Temperature vs Output Load

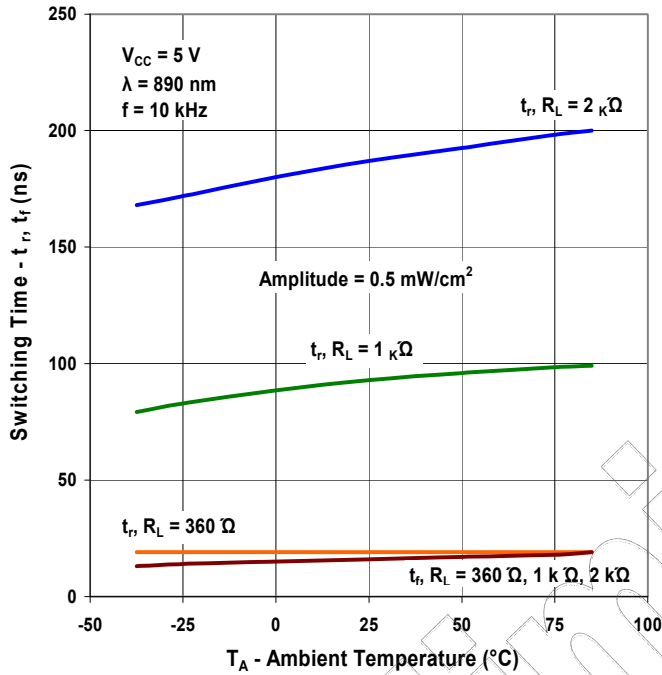

Propagation Delay vs Ambient Temperature

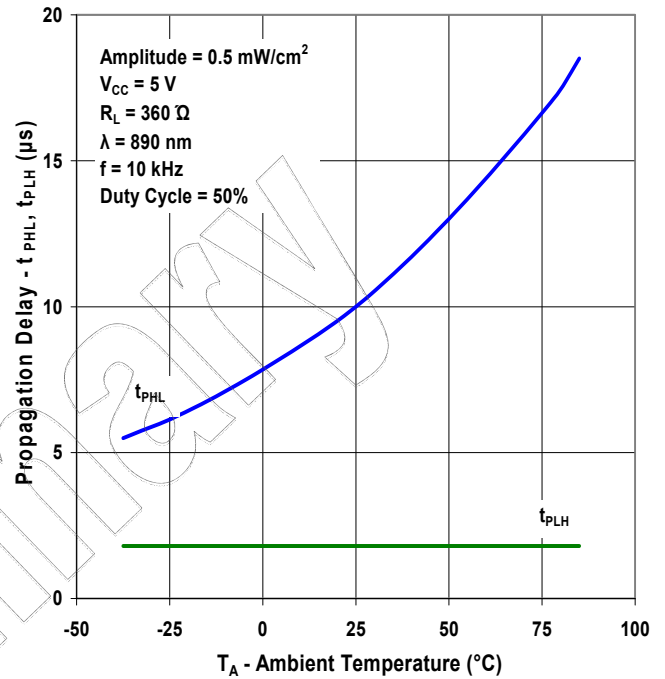

Sensor Output(s)

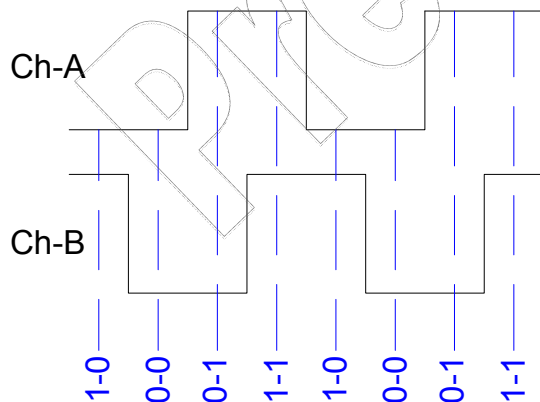

Ideal Target Size & Spacing For Linear or Circular Targets

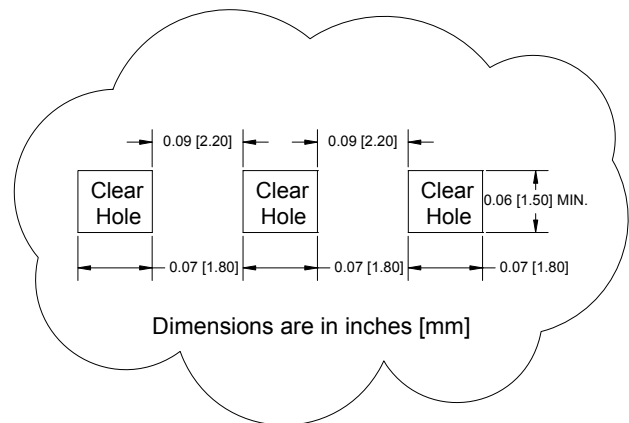

Please consult OPTEK for target design and sensor location relative to the target.

OPTEK Technology is TS 16949:2002 certified, any changes will be consistent with TS 16949:2002 procedures.

