



MCP3909
ADC Evaluation Board
for 16-Bit MCUs
User's Guide

Note the following details of the code protection feature on Microchip devices:

- Microchip products meet the specification contained in their particular Microchip Data Sheet.
- Microchip believes that its family of products is one of the most secure families of its kind on the market today, when used in the intended manner and under normal conditions.
- There are dishonest and possibly illegal methods used to breach the code protection feature. All of these methods, to our knowledge, require using the Microchip products in a manner outside the operating specifications contained in Microchip's Data Sheets. Most likely, the person doing so is engaged in theft of intellectual property.
- Microchip is willing to work with the customer who is concerned about the integrity of their code.
- Neither Microchip nor any other semiconductor manufacturer can guarantee the security of their code. Code protection does not mean that we are guaranteeing the product as "unbreakable."

Code protection is constantly evolving. We at Microchip are committed to continuously improving the code protection features of our products. Attempts to break Microchip's code protection feature may be a violation of the Digital Millennium Copyright Act. If such acts allow unauthorized access to your software or other copyrighted work, you may have a right to sue for relief under that Act.

Information contained in this publication regarding device applications and the like is provided only for your convenience and may be superseded by updates. It is your responsibility to ensure that your application meets with your specifications. MICROCHIP MAKES NO REPRESENTATIONS OR WARRANTIES OF ANY KIND WHETHER EXPRESS OR IMPLIED, WRITTEN OR ORAL, STATUTORY OR OTHERWISE, RELATED TO THE INFORMATION, INCLUDING BUT NOT LIMITED TO ITS CONDITION, QUALITY, PERFORMANCE, MERCHANTABILITY OR FITNESS FOR PURPOSE. Microchip disclaims all liability arising from this information and its use. Use of Microchip devices in life support and/or safety applications is entirely at the buyer's risk, and the buyer agrees to defend, indemnify and hold harmless Microchip from any and all damages, claims, suits, or expenses resulting from such use. No licenses are conveyed, implicitly or otherwise, under any Microchip intellectual property rights.

Trademarks

The Microchip name and logo, the Microchip logo, Accuron, dsPIC, KEELOQ, KEELOQ logo, MPLAB, PIC, PICmicro, PICSTART, rPIC, SmartShunt and UNI/O are registered trademarks of Microchip Technology Incorporated in the U.S.A. and other countries.

FilterLab, Linear Active Thermistor, MXDEV, MXLAB, SEEVAL, SmartSensor and The Embedded Control Solutions Company are registered trademarks of Microchip Technology Incorporated in the U.S.A.

Analog-for-the-Digital Age, Application Maestro, CodeGuard, dsPICDEM, dsPICDEM.net, dsPICworks, dsSPEAK, ECAN, ECONOMONITOR, FanSense, In-Circuit Serial Programming, ICSP, ICEPIC, Mindi, MiWi, MPASM, MPLAB Certified logo, MPLIB, MPLINK, mTouch, PICkit, PICDEM, PICDEM.net, PICTail, PIC³² logo, PowerCal, PowerInfo, PowerMate, PowerTool, REAL ICE, rLAB, Select Mode, Total Endurance, WiperLock and ZENA are trademarks of Microchip Technology Incorporated in the U.S.A. and other countries.

SQTP is a service mark of Microchip Technology Incorporated in the U.S.A.

All other trademarks mentioned herein are property of their respective companies.

© 2008, Microchip Technology Incorporated, Printed in the U.S.A., All Rights Reserved.

 Printed on recycled paper.

QUALITY MANAGEMENT SYSTEM
CERTIFIED BY DNV
== ISO/TS 16949:2002 ==

Microchip received ISO/TS-16949:2002 certification for its worldwide headquarters, design and wafer fabrication facilities in Chandler and Tempe, Arizona; Gresham, Oregon and design centers in California and India. The Company's quality system processes and procedures are for its PIC[®] MCUs and dsPIC[®] DSCs, KEELOQ[®] code hopping devices, Serial EEPROMs, microperipherals, nonvolatile memory and analog products. In addition, Microchip's quality system for the design and manufacture of development systems is ISO 9001:2000 certified.



MCP3909 ADC EVALUATION BOARD FOR 16-BIT MCUs USER'S GUIDE

Table of Contents

Preface	1
Introduction.....	1
Document Layout	1
Conventions Used in this Guide	2
Recommended Reading.....	3
The Microchip Web Site	3
Customer Support	3
Document Revision History	3
Chapter 1. Hardware Description	
1.1 Overview	5
1.2 PIM Module / MCP3909 Connection and Peripheral Usage Overview	7
1.3 MCP3909 Delta-Sigma Sampling / MCLK Options	8
1.4 Analog Input Structure	9
1.5 Universal Serial Bus (USB)	9
Chapter 2. Firmware	
2.1 DSPIC33 Firmware Description	11
2.2 Display Mode Control - SW2	13
2.3 Sampling Speed Rate Control - SW3	13
2.4 Data Acquisition	13
2.5 Data Transmission	15
Chapter 3. MCP3909 PC Software Tool	
3.1 Software Overview	17
3.2 Setting the Sample Rate	18
3.3 Connectivity, Recording Length and Calibration of Data	18
3.4 Scope Plot Window - Time Domain Analysis	18
3.5 Histogram Window - Noise Analysis	19
3.6 FFT Window - Frequency Domain Analysis	19
3.7 Auxiliary Data Window	19

MCP3909 ADC Evaluation Board for 16-Bit MCUs User's Guide

Appendix A. Schematics and Layouts

A.1 Introduction	21
A.2 Schematic - Analog	22
A.3 Schematic - LCD And UART	23
A.4 Schematic - USB And Memory	24
A.5 Schematic - Microcontroller (MCU)	25
A.6 Schematic - PIM Module	26
A.7 Schematic - Power	27
A.8 Board - Top Trace and Top Silk	28
A.9 Board - Bottom Trace and Bottom Silk	28
A.10 Board - Layer #2 VDD	29
A.11 Board - Layer #3 GND	29
A.12 Board -Top Silk and Pads	30
A.13 Board - Bottom Silk and Pads	30

Appendix B. Bill of Materials (BOM)

Worldwide Sales and Service	34
-----------------------------------	----



MCP3909 ADC EVALUATION BOARD FOR 16-BIT MCUs USER'S GUIDE

Preface

NOTICE TO CUSTOMERS

All documentation becomes dated, and this manual is no exception. Microchip tools and documentation are constantly evolving to meet customer needs, so some actual dialogs and/or tool descriptions may differ from those in this document. Please refer to our web site (www.microchip.com) to obtain the latest documentation available.

Documents are identified with a “DS” number. This number is located on the bottom of each page, in front of the page number. The numbering convention for the DS number is “DSXXXXA”, where “XXXX” is the document number and “A” is the revision level of the document.

For the most up-to-date information on development tools, see the MPLAB® IDE on-line help. Select the Help menu, and then Topics to open a list of available on-line help files.

INTRODUCTION

This chapter contains general information that will be useful to know before using the MCP3909 ADC Evaluation Board for 16-Bit MCUs. Items discussed in this chapter include:

- Document Layout
- Conventions Used in this Guide
- Recommended Reading
- The Microchip Web Site
- Customer Support
- Document Revision History

DOCUMENT LAYOUT

This document describes how to use the MCP3909 ADC Evaluation Board for 16-Bit MCUs as a development tool to emulate and debug firmware on a target board. The manual layout is as follows:

- **Chapter 1. “Hardware Description”**– Provides important information about the MCP3909 ADC Evaluation Board for 16-Bit MCUs hardware.
- **Chapter 2. “Firmware”**– Describes the MCP3909 ADC Evaluation Board for 16-Bit MCUs firmware.
- **Chapter 3. “MCP3909 PC Software Tool”** – Provides detailed information about board’s PC software tool.
- **Appendix A. “Schematics and Layouts”**– Shows the schematic and board layouts for the MCP3909 ADC Evaluation Board for 16-Bit MCUs.
- **Appendix B. “Bill of Materials (BOM)”** – Lists the parts used to build the MCP3909 ADC Evaluation Board for 16-Bit MCUs.

MCP3909 ADC Evaluation Board for 16-Bit MCUs User's Guide

CONVENTIONS USED IN THIS GUIDE

This manual uses the following documentation conventions:

DOCUMENTATION CONVENTIONS

Description	Represents	Examples
Arial font:		
Italic characters	Referenced books	<i>MPLAB[®] IDE User's Guide</i>
	Emphasized text	...is the <i>only</i> compiler...
Initial caps	A window	the Output window
	A dialog	the Settings dialog
	A menu selection	select Enable Programmer
Quotes	A field name in a window or dialog	"Save project before build"
Underlined, italic text with right angle bracket	A menu path	<u><i>File>Save</i></u>
Bold characters	A dialog button	Click OK
	A tab	Click the Power tab
N'Rnnnn	A number in verilog format, where N is the total number of digits, R is the radix and n is a digit.	4'b0010, 2'hF1
Text in angle brackets < >	A key on the keyboard	Press <Enter>, <F1>
Courier New font:		
Plain Courier New	Sample source code	#define START
	Filenames	autoexec.bat
	File paths	c:\mcc18\h
	Keywords	_asm, _endasm, static
	Command-line options	-Opa+, -Opa-
	Bit values	0, 1
	Constants	0xFF, 'A'
Italic Courier New	A variable argument	<i>file.o</i> , where <i>file</i> can be any valid filename
Square brackets []	Optional arguments	mcc18 [options] <i>file</i> [options]
Curly brackets and pipe character: { }	Choice of mutually exclusive arguments; an OR selection	errorlevel {0 1}
Ellipses...	Replaces repeated text	var_name [, var_name...]
	Represents code supplied by user	void main (void) { ... }

RECOMMENDED READING

This user's guide describes how to use MCP3909 ADC Evaluation Board for 16-Bit MCUs. Other useful documents are listed below. The following Microchip document is available and recommended as supplemental reference resources:

- **MCP3909 Data Sheet - “Energy Metering IC with SPI Interface and Active Power Pulse Output” (DS22025)**

THE MICROCHIP WEB SITE

Microchip provides online support via our web site at www.microchip.com. This web site is used as a means to make files and information easily available to customers. Accessible by using your favorite Internet browser, the web site contains the following information:

- **Product Support** – Data sheets and errata, application notes and sample programs, design resources, user's guides and hardware support documents, latest software releases and archived software
- **General Technical Support** – Frequently Asked Questions (FAQs), technical support requests, online discussion groups, Microchip consultant program member listing
- **Business of Microchip** – Product selector and ordering guides, latest Microchip press releases, listing of seminars and events, listings of Microchip sales offices, distributors and factory representatives

CUSTOMER SUPPORT

Users of Microchip products can receive assistance through several channels:

- Distributor or Representative
- Local Sales Office
- Field Application Engineer (FAE)
- Technical Support

Customers should contact their distributor, representative or field application engineer (FAE) for support. Local sales offices are also available to help customers. A listing of sales offices and locations is included in the back of this document.

Technical support is available through the web site at: <http://support.microchip.com>.

DOCUMENT REVISION HISTORY

Revision A (November 2008)

- Initial Release of this Document.

MCP3909 ADC Evaluation Board for 16-Bit MCUs User's Guide

NOTES:



MCP3909 ADC EVALUATION BOARD FOR 16-BIT MCUs USER'S GUIDE

Chapter 1. Hardware Description

1.1 OVERVIEW

The MCP3909 ADC Evaluation Board for 16-Bit MCUs system provides the ability to evaluate the performance of the MCP3909 dual channel ADC. It also provides a development platform for 16-bit PIC based applications, using existing 100-pin PIM systems compatible with the Explorer-16 and other high pincount PIC demo boards. The system comes with programmed PIC24FJ128GA010 and dsPIC33FJ256GP710 PIM modules that communicate both to on-board LCD and a LabView GUI for both in-circuit and PC signal processing.

1.1.1 Feature Highlights

- Dual 16-bit ADC MCP3909 output display using Serial communication to PC Software Interface
- Simultaneous 15 ksp/s at 81 dB SINAD performance on dual 16-Bit MCP3909 channels
- Spectral Analysis using DFT dsPIC33F calculations, resolution of TBD/Hz
- System and ADC performance analysis through graphical PC tools showing Noise Histogram, Frequency Domain (FFT), Time domain scope plot, and statistical numerical analysis
- Robust hardware design with analog grounding and analog/digital separation, allowing low noise evaluation of MCP3909 devices. Separate power supplies and power planes - 4 layer board
- Pigtail Plus connectors for Explorer-16 daughter board compatibility

MCP3909 ADC Evaluation Board for 16-Bit MCUs User's Guide

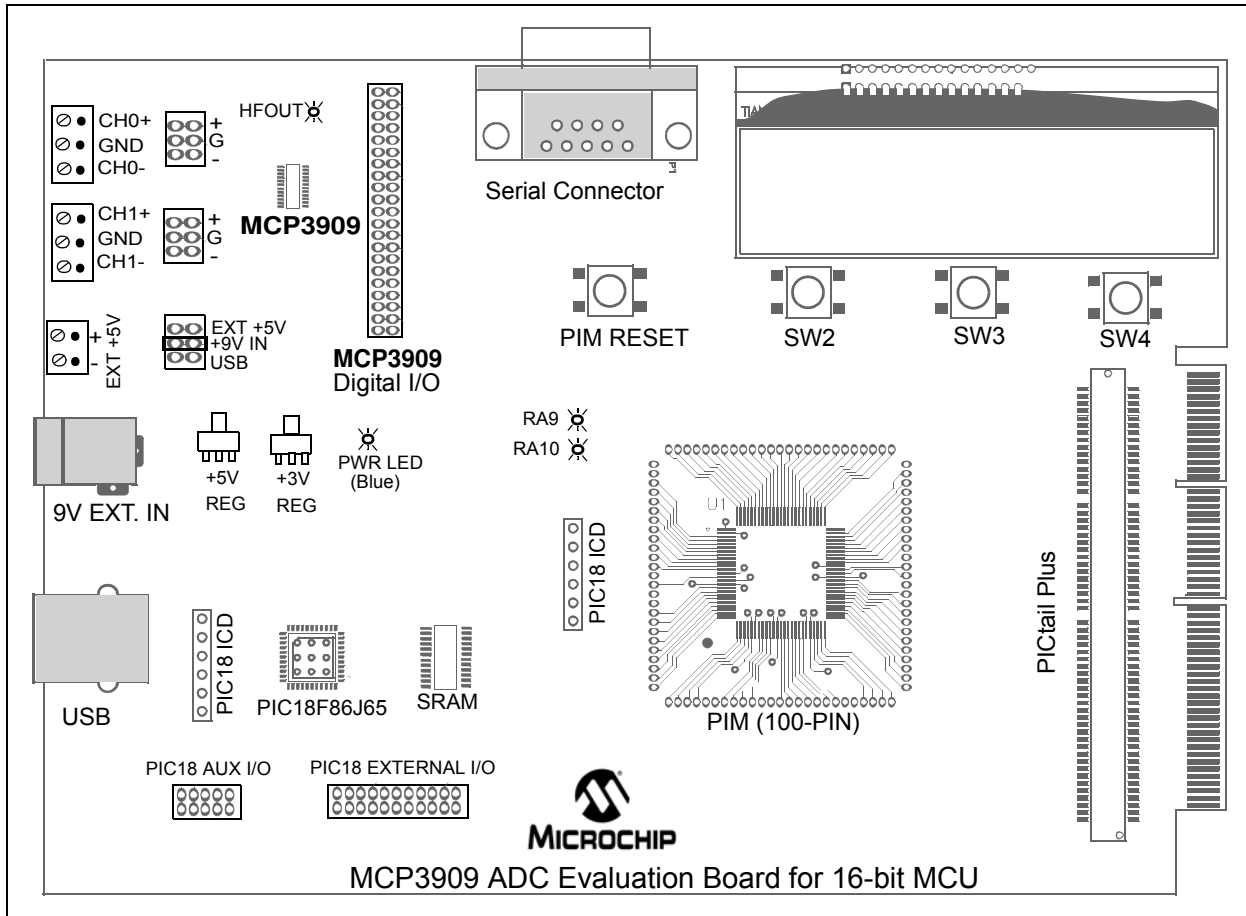

FIGURE 1-1: Evaluation Board Block Diagram.

1.2 PIM MODULE / MCP3909 CONNECTION AND PERIPHERAL USAGE OVERVIEW

The MCP3909 ADC Evaluation Board for 16-Bit MCUs contains a 100-pin PIM socket compatible with Microchip's PIM modules. The system comes with 2 PIM modules: the PIC24FJ128GA010 and dsPIC33FJ256GA710.

A complete description of the firmware programmed with these two modules see in **Chapter 1. "Hardware Description"**.

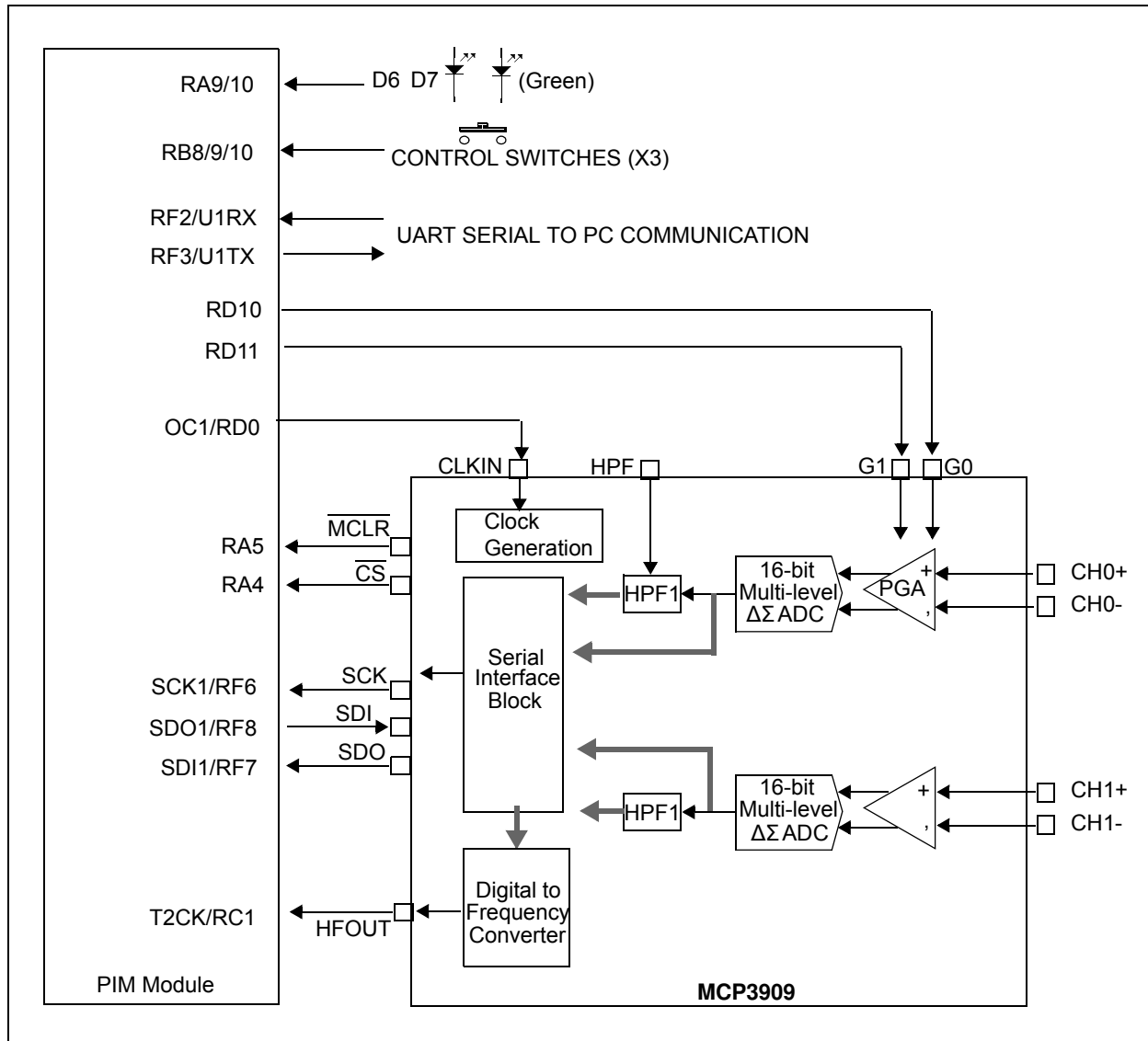

FIGURE 1-2: Digital Connection Overview PIM/MCP3909 connections.

Ports A, B, and D are used for signals such as push buttons, output LEDs, \overline{CS} and \overline{MCLR} (for MCP3909 data mode setting). Output Capture 1 is used for MCP3909's clock generation. Serial communication is achieved through the MSSP module 1, and the Timer2 Capture Compare can be used to measure MCP3909 active power output frequency (HFOUT).

MCP3909 ADC Evaluation Board for 16-Bit MCUs User's Guide

1.3 MCP3909 DELTA-SIGMA SAMPLING / MCLK OPTIONS

The MCP3909 device is an ADC with a second order modulator and a third order sinc filter. This Delta-Sigma A/D converter has an oversampling ratio of 64. The CLKIN pin of the MCP3909 is the oversampling clock (MCLK) input and the output data rate is MCLK/256. The MCP3909 ADC Evaluation Board for 16-Bit MCUs offers two different options for the MCP3909 master clock (MCLK).

1.3.1 Using the Crystal X2

The MCP3909 ADC Evaluation Board for 16-Bit MCUs is populated with a 3.58 MHz crystal, being used as a clock source by placing jumpers in the following position on the MCP3909 Digital I/O header block:

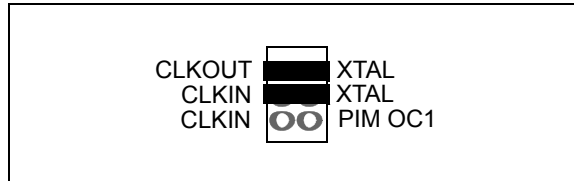

FIGURE 1-3: ADC Clock Selection Jumpers - External Crystal.

1.3.2 Driving the clock with the PIM module

The PIC MCU can be used to generate the CLKIN (MCLK) signal for the MCP3909, setting the ADC sample rate through the use of the output compare module OC1. To use this, make the following jumper change to the MCP3909 Digital I/O header block:

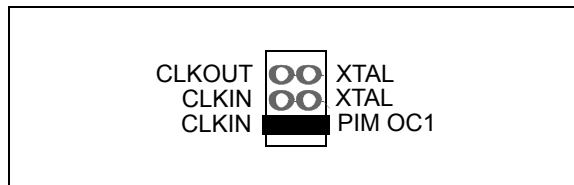

FIGURE 1-4: ADC Clock Selection Jumpers - Clock from MCU.

The frequency of the OC1 output is based on the PR1 bits settings in the firmware (for both PIC24 and dsPIC33 PIM modules supplied with this system). These settings can be cycled through by pressing SW2 of the PIM AUX Switches. The Table 1-1 shows the settings that are immediately available by changing PR2, the timer period register:

TABLE 1-1: SAMPLE RATES

Gear	PR Bit Setting	OC1 Frequency	MCP3909 Data Rate
1	48	164.96 kHz	644.2 sps
2	14	758.7 kHz	2.96 ksps
3	8	1264.36 kHz	4.94 ksps
4	4	2.2755 MHz	8.89 ksps
5	2	3.7921 MHz	14.81 ksps

1.4 ANALOG INPUT STRUCTURE

Two differential input paths allow external signal sources to be easily connected to the MCP3909 input. Edge connectors P1 and P2 are 3-pin connectors that act as both crew type and clip on post connectors.

Note: To use an edge connector as a post connector, pull up the blue plastic top to access posts.

JP1 and JP2 can be used to force either channel from a differential to single-ended configuration. R3 and R4 (on CH0), and R1 and R2 (on CH2) act as locations for burden resistor connectors for any current transformer inputs.

1.5 UNIVERSAL SERIAL BUS (USB)

The MCP3909 ADC Evaluation Board for 16-Bit MCUs also contains a USB connection for higher speed sampling and data collection. The circuit includes a 512 x 8 SRAM for data collection. The following figure summarizes the connections between the ADC, 2 micros, and memory.

Note: For this board release, no USB firmware is supplied. The PIC18F86J55 is blank and only included for development purposes.

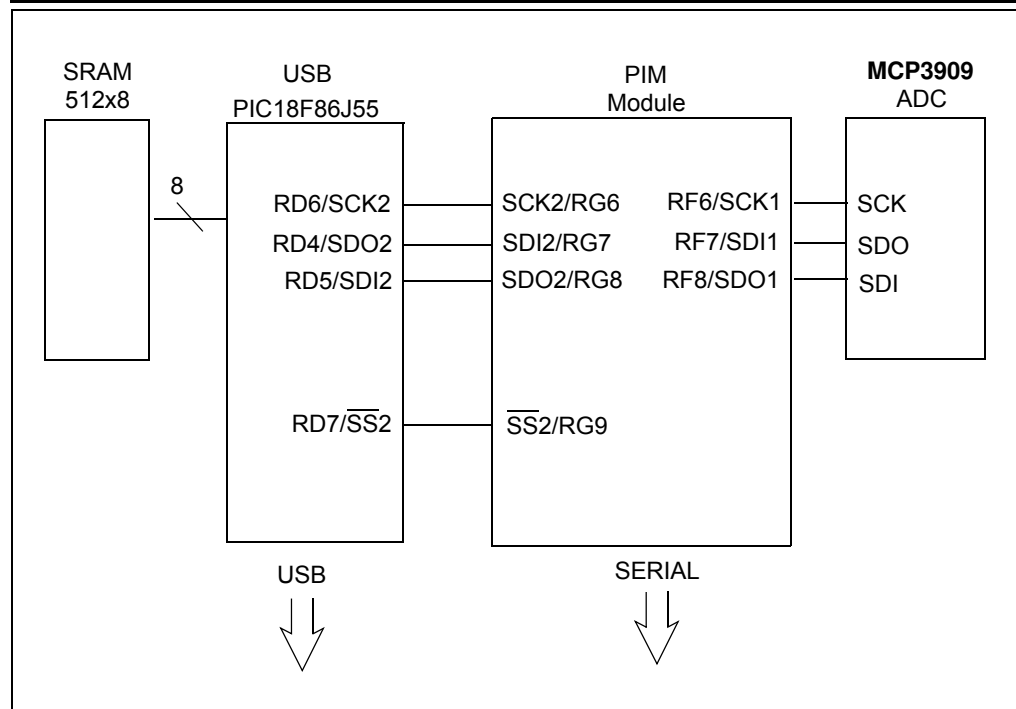

FIGURE 1-5: USB Block Diagram.

MCP3909 ADC Evaluation Board for 16-Bit MCUs User's Guide

NOTES:

Chapter 2. Firmware

2.1 DSPIC33 FIRMWARE DESCRIPTION

2.1.1 Reset and Initialization

After reset, the code jumps to line 305 from *main.c* file, where the initialization routine is called: `Initialization()`. First, the nested interrupts are disabled. External interrupt 3 is enabled on the negative edge. Timer 2 is running on the Output Compare 1, being used to generate the clock for the MCP3909. In addition, some initial values are set up for the MCP3909 clock frequency.

Timer 5 is enabled and set to generate an interrupt at compare mach; the time period between two interrupts is a few hundred milliseconds.

Note: The time period can be changed from PR5 register.

The SPI module is initialized and started, but the corresponding interrupt is not enabled. UART transmitter is initialized, but the corresponding interrupt is not enabled. Communication speed is set for 115200 baud. The UART receiver is not used.

Pins with analogue alternate function are setup as digital-input outputs. Initial values for different variables are being set at the end of the initialization routine.

Back in the `void main()` routine the nested interrupts are enabled. Then the routine that starts the MCP3909 is called: `startMCP3909()`.

2.1.2 startMCP3909()

During this routine the MCP3909 is put into a test mode, according to the MCP3909 data sheet. At the beginning \overline{CS} and MCP3909 reset pins (MCLR) have high values. After a slight delay, MCLR is toggled low, and then the serial command `b10100100` is sent to the device. This means that the ADC is placed into "Dual Channel Output PRE HPF1" mode. Then, a short positive pulse is sent to \overline{CS} .

2.1.3 Main()

In the `main()` file, the LCD will display the samples values.

At this point, the Main routine will enter an infinite loop. All the other tasks are being done during the interrupt routines.

2.1.4 Timer 5 Compare Mach Interrupt

All events that don't need to take place to a repeated, constant period of time are processed during this interrupt. One event that is happening at the time of this routine is the blinking of LED D7 - as a life sign for the system. This routine is monitoring the buttons state (pressed or not pressed), and also counts how many times each of them have been pressed.

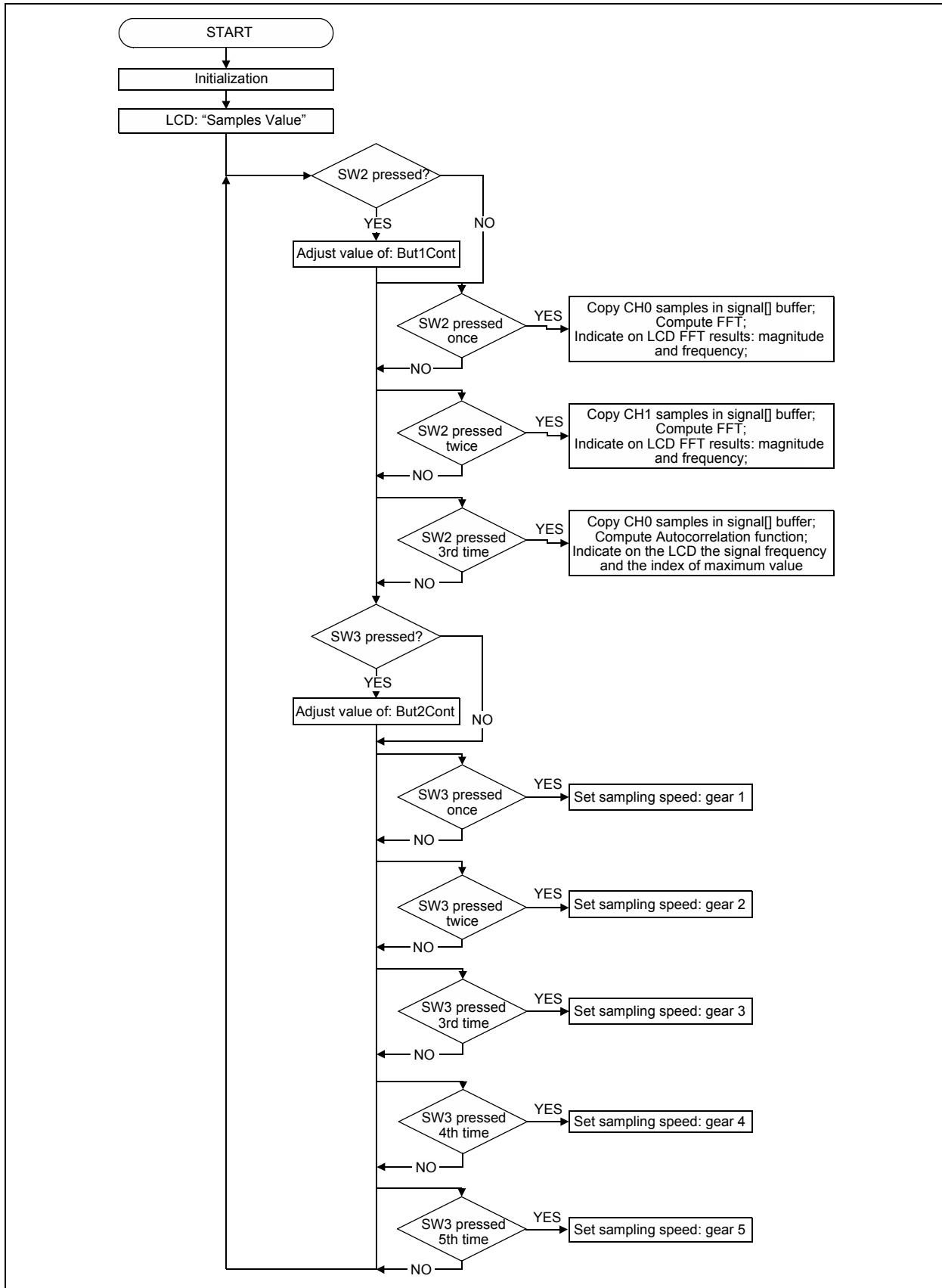

FIGURE 2-1: LCD Control Flowchart.

2.2 DISPLAY MODE CONTROL - SW2

Table 2-1 describes the actions made to the SW2 button, and the results shown on the LCD.

TABLE 2-1: LCD MESSAGE DURING SW2 MANIPULATION

Type of Operation	LCD Screen Results
NEVER PRESSED	LCD indicates the same message as the one during the reset time: samples values.
1 st Time	LCD shows the results of the FFT performed on CH0.
2 nd Time	LCD shows the results of the FFT performed on samples recorded from CH1.
3 rd Time	LCD indicates the results form the auto-correlation function: signal frequency and the index of maximum of the auto-correlation function.

2.3 SAMPLING SPEED RATE CONTROL - SW3

SW3 button is used to control the sampling speed rate of the ADC by changing the frequency of the MCP3909 clock signal.

The initial sampling frequency rate is around 640 sps. For a 64 sample buffer it means a 0.1s recording buffer.

Table indicates estimated values for the sampling frequency when operating the SW3 button:

TABLE 2-2: RESULTS DURING SW3 MANIPULATION

Type of Operation	Sampling Frequency Rate Estimation
Pressed 1 st time	The sampling speed rate is to 2000 sps.
Pressed 2 nd time	The sampling frequency rate is 3800 sps.
Pressed 3 rd time	The sampling frequency rate is 7600 sps.
Pressed 4 th time	The sampling speed rate is 15000 sps.

These higher sampling rates can be used when the measured signal has a high frequency, or when a signal doesn't have a stable frequency and we want to measure its amplitude. For higher sampling rate the measurement error induced by the Sinc filter is reduced.

Note: Important! When using the GUI for evaluation, the 'gear' on the GUI must be set to the speed on the board, i.e. 1st, 2nd, 3rd, etc.

2.4 DATA ACQUISITION

External interrupt 3 is used for detecting the end of conversion on MCP3909. Because this line is the same with the SPI data output, the first thing done after the detection of an external interrupt is to disable this particular interrupt. Otherwise an interrupt will be generated on each falling edges of the SPI signal.

Then the setup for the SPI is changed: it will be used in 16-bit mode, and the interrupt is activated. The SPIBUF register is being read to clear the SPI interrupt flag. For the first 16 periods of SPI clock, 0 value will be send to the MCP3909.

The SPI interrupt takes place after each successful data transfer between master and slave on SPI. As in any interrupt, first thing to do is to clear the interrupt flag, otherwise a new interrupt will happen again, for no reason.

MCP3909 ADC Evaluation Board for 16-Bit MCUs User's Guide

The CCSPI global value is the counter that indicates if the SPI happens soon after the INT3, and the value present in the SPI is CH0, or if a previous SPI interrupt happened and now is time to save value of CH1. After saving the samples into MCU, a small pulse is sent on CS, to the MCP3909, to prepare it for a new conversion. The acquired data is saved in form of two vectors in SRAM, one for CH0 and ne for CH1.

Finally, the Timer 5 interrupt and UART TX interrupt are enabled. The first Character sent to UART is: !.

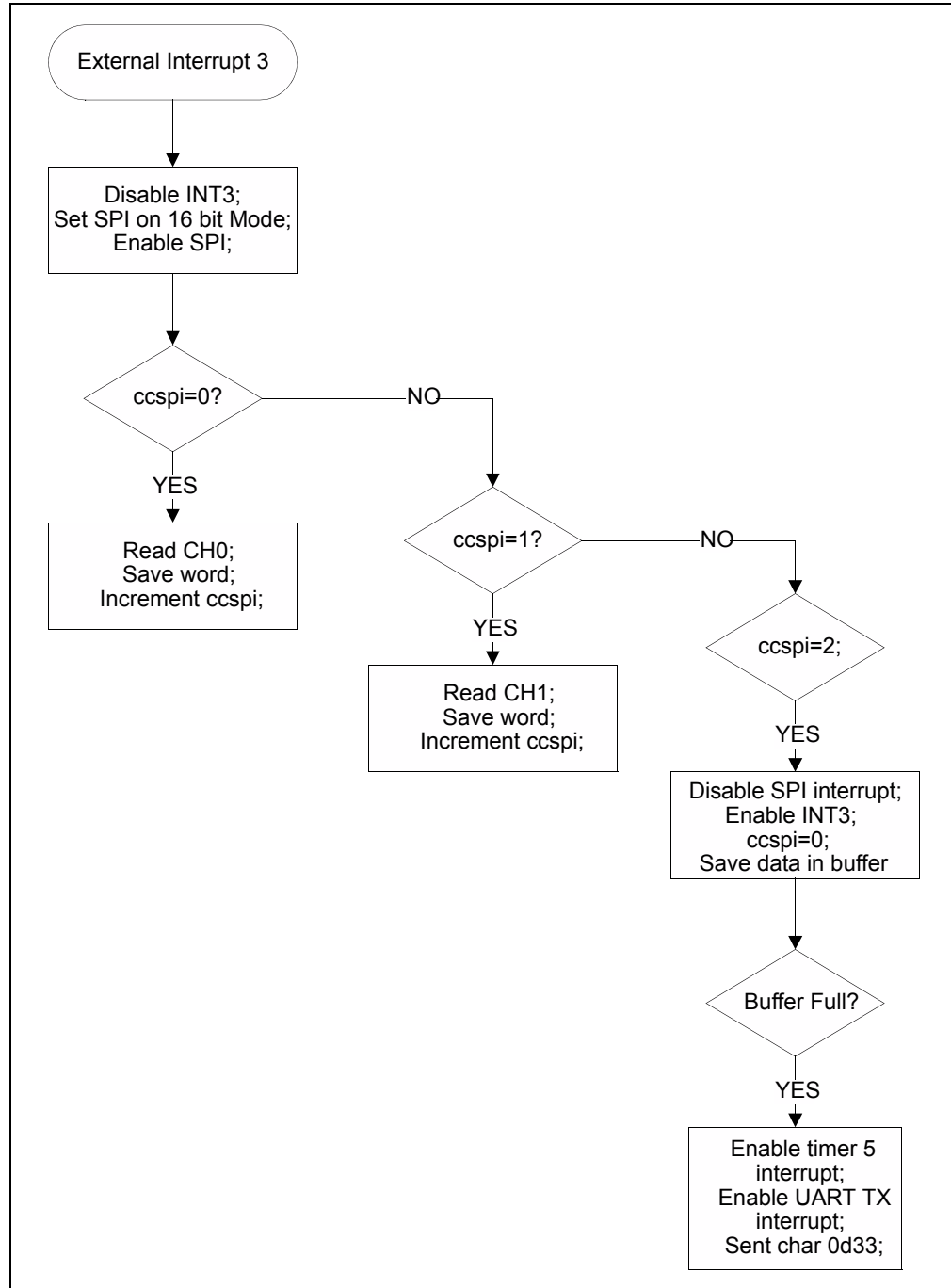

FIGURE 2-2: ADC Communication Flowchart.

2.5 DATA TRANSMISSION

When UART TX interrupt takes place, data is extracted from SRAM as a 16-bit number, then translated into STRING. Each word is converted into a five digit number without sign.

During transmission, the digits with the values of CH0 are sent first, then the character ','. Next are the five digits of the CH1, and last, the character Carriage return. This is done 512 times.

After the transmission of the acquired samples, the FFT value must be sent on UART. To delimit the buffer of the acquired samples from FFT values, character ';' is being sent.

The FFT information is sent in the same manner as the stored samples (five digit numbers delimited by ',' and CR), but the FFT length is limited to 128 values. These values are used by the GUI to compare the FFT computed into the MCU to the one computed on the PC.

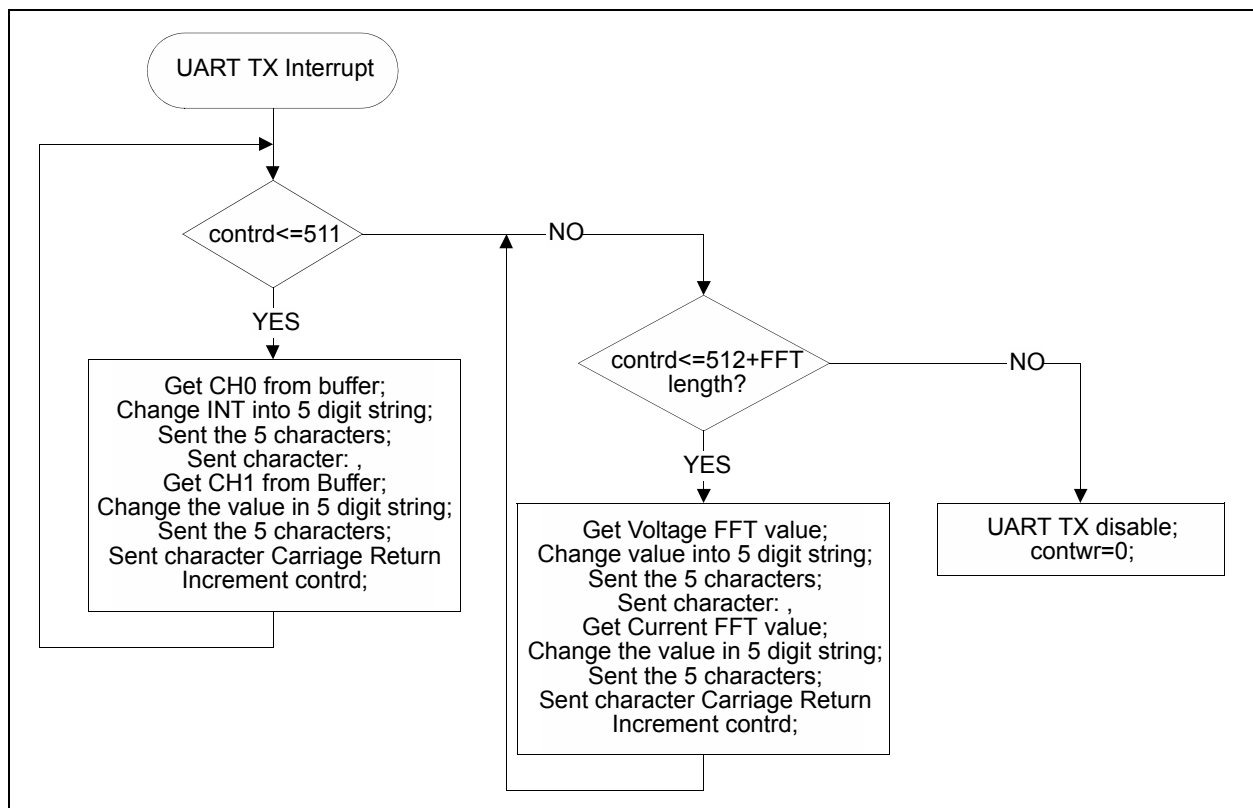

FIGURE 2-3: Serial Transmission Flowchart.

MCP3909 ADC Evaluation Board for 16-Bit MCUs User's Guide

NOTES:

Chapter 3. MCP3909 PC Software Tool

3.1 SOFTWARE OVERVIEW

The MCP3909 ADC Evaluation Board for 16-Bit MCUs includes a PC graphical user interface (GUI) that performs data analysis for easier system debugging and device evaluation. The following figure a sample of the software's GUI.

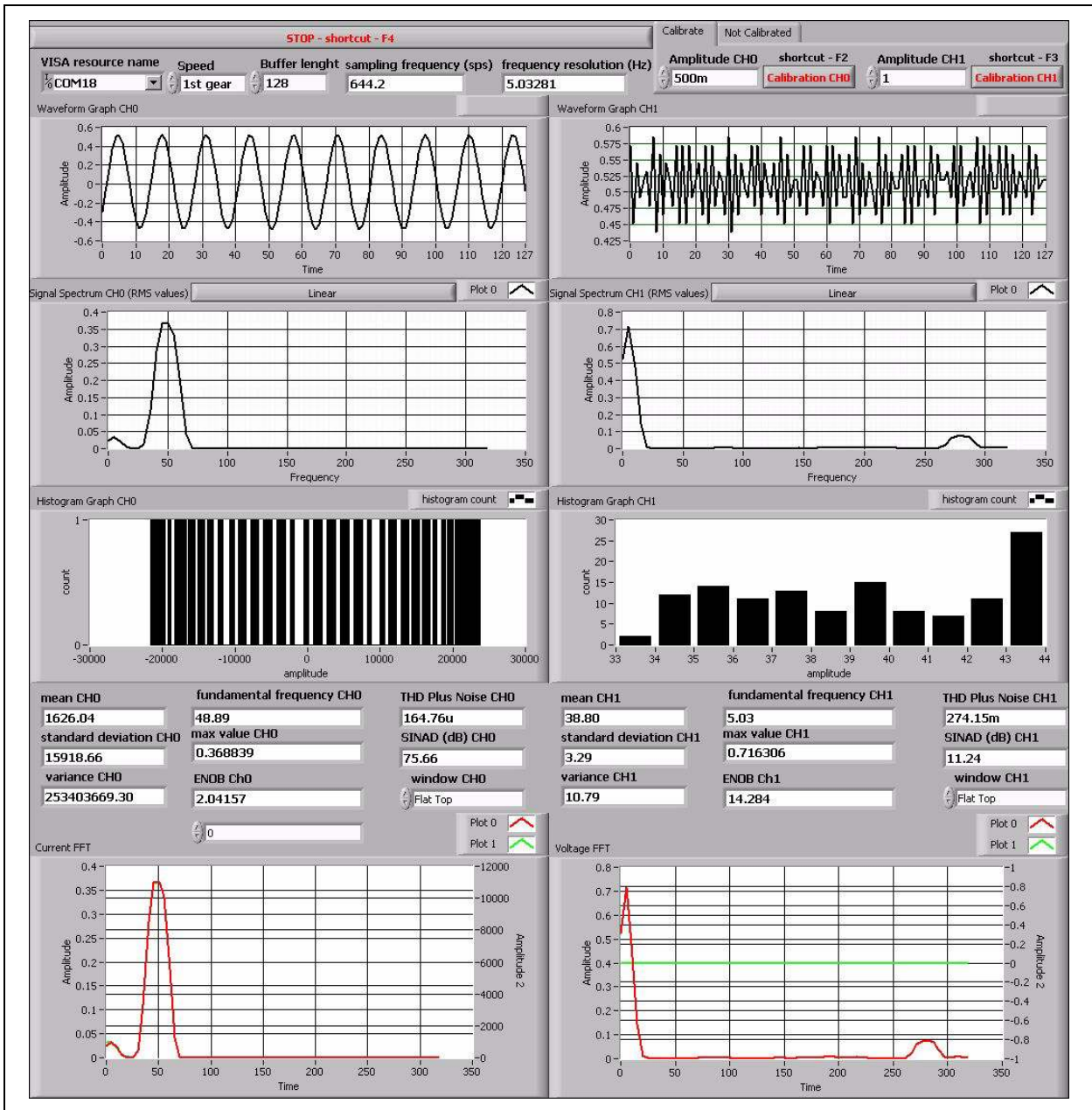

FIGURE 3-1: Data View Interface.

3.2 SETTING THE SAMPLE RATE

On the MCP3909 ADC Evaluation Board for 16-Bit MCUs is possible to select from five different sampling rates, referred here as gears. The control is placed in the up left areas of the GUI.

The value of the sampling rate for each gear is as follows:

- 1st gear - 644.2 sps
- 2nd gear - 2963 sps
- 3th gear - 4938 sps
- 4th gear - 8888 sps
- 5th gear - 14813 sps

Once the gear is changed, the actualized value of the sampling rate is indicated on the "Sampling Frequency (sps)" field. The "Frequency Resolution" field will indicate the space between spectral lines of the sampled signal, at the indicated sample rate.

Changing the sampling rate in the GUI will not automatically change the one on the MCP3909 ADC Evaluation Board for 16-Bit MCUs. For this to happen it is necessary to manually change the gear, by pressing the RB9 button placed on the board.

3.3 CONNECTIVITY, RECORDING LENGTH AND CALIBRATION OF DATA

The PC is connected to the MCP3909 ADC Evaluation Board for 16-Bit MCUs through the RS232 cable. It is important to have a COM port on the PC. It is possible to use a USB to RS232 adaptor cable, for this case being necessary to write the number of the virtual COM port. To do this, right-click on *My computer > Manage > Device Manager > Port (COM and LPT)*, and read the number in the parenthesis, after the device name.

The COM port number must be selected in the "VISA Resource Name" field.

The MCU is sending a big packet of data to the PC. If the user need to see only to a small part of the buffer, he will write the desired buffer length in the "Buffer length" field. The maximum length is 512 samples.

The user have the option to choose between **Calibrate** and **Not Calibrate** tab from the up-right corner of the window. The calibration is possible for an AC signal measurement, calibrating the scale and selecting the desired unit of measure for the processed data.

When selecting the **Calibrate** tab, two fields are shown: the "Amplitude CH0" and the "Amplitude CH1", with the corresponding Calibration buttons. The user must write the peak-to-peak value in the two fields, and then press the **Calibration** button for each, or use the shortcuts (<F2> for CH0 and <F3> for CH1). If the **Calibration** button is not pressed, or the shortcut is not applied, plot screens will be empty.

If the **Not Calibrated** tab is selected, the "Amplitude" fields and **Calibration** buttons are not visible, and the data plotted on the screen will be indicated in LSBs (in ADC code).

To stop the GUI it is necessary to press the **STOP** button, or the <F4> shortcut key.

3.4 SCOPE PLOT WINDOW - TIME DOMAIN ANALYSIS

The recorded samples from a buffer are indicated on the "Waveform Graphs" screens.

The size of the X scale is given by the number showed in the "Buffer Length" field.

If the **Not Calibrated** tab is selected, the value on Y axis will be given by the LSBs. If the data is calibrated, and calibration value is 0.5, for example, the data on the waveform graphs will have an amplitude peak-to-peak of 2x0.5. It is important to note that the offset is not removed.

3.5 HISTOGRAM WINDOW - NOISE ANALYSIS

For the evaluation of the Effective Number Of Bits (ENOB) the GUI will compute some statistical parameters: “mean” value, “standard deviation” and “variance”, for each channel. These parameters can be seen at the bottom of the GUI, right under the Histogram Graph screens. The formula used for the ENOB is:

EQUATION 3-1:

$$ENOB = 16 - \log_2(\sigma)$$

The right value for the acquired ENOB is correct only when the DC signal is applied on the inputs.

The distribution of noise from the acquired signal can be seen on the Histogram Graph screens. These graphs are indicating how many transitions took place in between two codes. In the case of a noiseless signal (a straight line), the histogram graphs will show nothing. If the signal is a digital noise signal (transition between two values) the histogram will indicate just one vertical bar.

3.6 FFT WINDOW - FREQUENCY DOMAIN ANALYSIS

The spectrum of the acquired signal is visible in the Signal Spectrum screen. Above these graphics there is a button that can be used to set the Y scale to be linear or logarithmic. A logarithmic scale on Y axis is useful to see the level of low harmonics, or the noise floor.

The length of the FFT is given by the buffer length and the sampling speed. The X axis is directly scaled in Hz units. Do remember when changing the sampling speed in the GUI, to manually change the sampling speed on the MCP3909 ADC Evaluation Board for 16-Bit MCUs.

Another feature of the software is the window selection for the FFT computation. This is done from the “Window” fields, in the lower region of the GUI, right above the Current FFT screens. The user can select from a large number of windows.

Since GUI is performing the spectral analysis of the acquired signal, it is possible to compute AC performance parameters of the ADC: “THD” and “SINAD” are shown on the indicators, right under the Histogram Graph screens.

3.7 AUXILIARY DATA WINDOW

At the bottom of the GUI there are two screens called Current FFT and Voltage FFT. These graphics are used to compare the FFT computed on the MCU (the green FFT) with the one computed on the PC (the red FFT). The Current channel is CH0, and the Voltage channel is CH1.

In the beginning these graphs do not indicate anything. For a correct use it is necessary to have the same window used on both MCU and PC. In addition, on the PC, the Linear scale for the FFT must be used.

Because on the MCU the FFT has 128 points in length, the buffer length should be the same.

The MCU is not sending the data to the PC simultaneously. To choose which view to see (Current FFT or Voltage FFT), press SW3 placed on the board.

MCP3909 ADC Evaluation Board for 16-Bit MCUs User's Guide

NOTES:



MCP3909 ADC EVALUATION BOARD FOR 16-BIT MCUs USER'S GUIDE

Appendix A. Schematics and Layouts

A.1 INTRODUCTION

This appendix contains the following schematics of the MCP3909 ADC Evaluation Board for 16-Bit MCUs.

- Schematic - Analog
- Schematic - LCD and UART
- Schematic - USB and Memory
- Schematic - Microcontroller (MCU)
- Schematic - PIM Module
- Schematic - Power
- Board - Top Trace and Top Silk
- Board - Bottom Trace and Bottom Silk
- Board - Layer #2 V_{DD}
- Board - Layer #3 GND
- Board - Top Silk and Pads
- Board - Bottom Silk and Pads

MCP3909 ADC Evaluation Board for 16-Bit MCUs User's Guide

A.2 SCHEMATIC - ANALOG

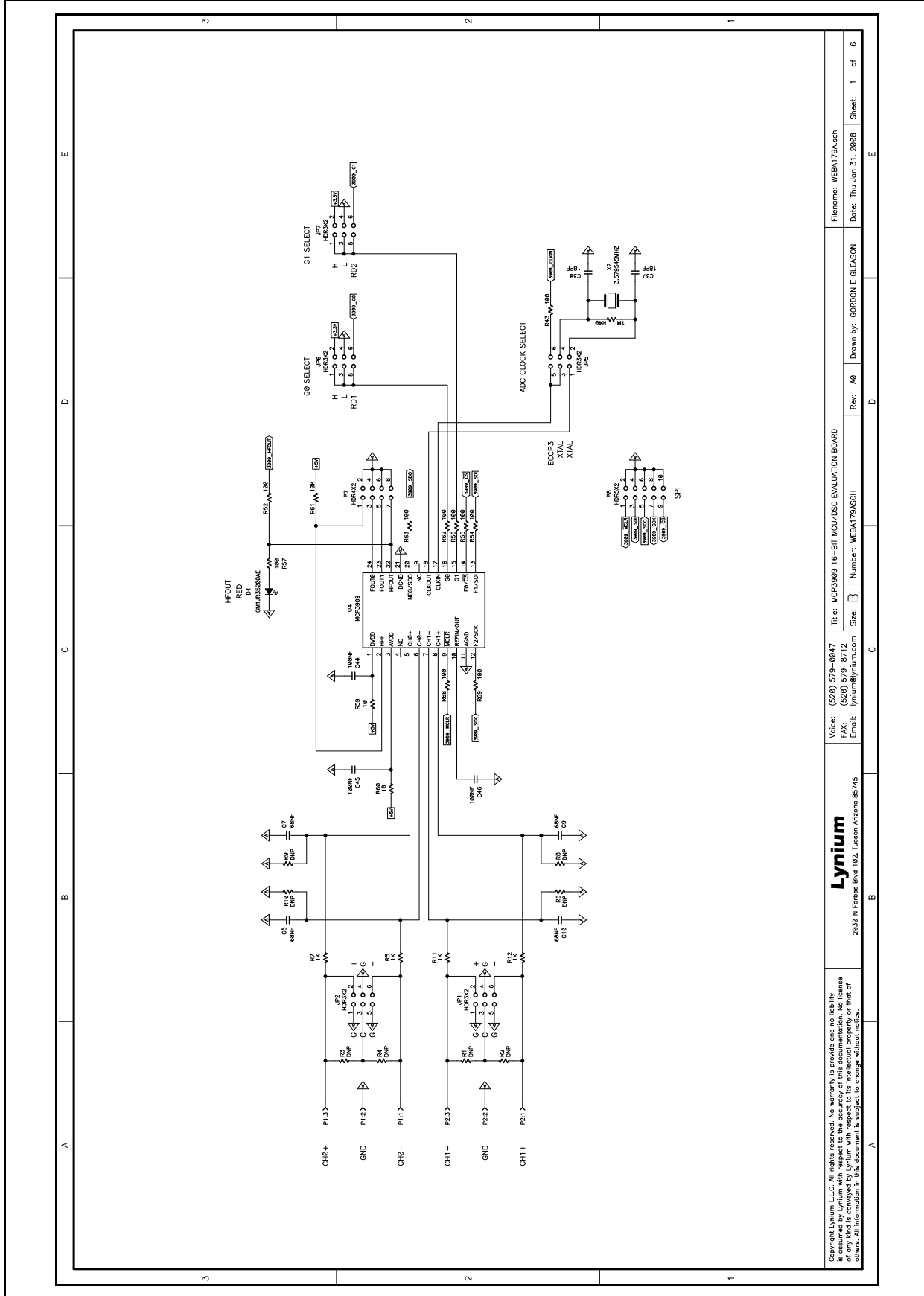

A.3 SCHEMATIC - LCD AND UART

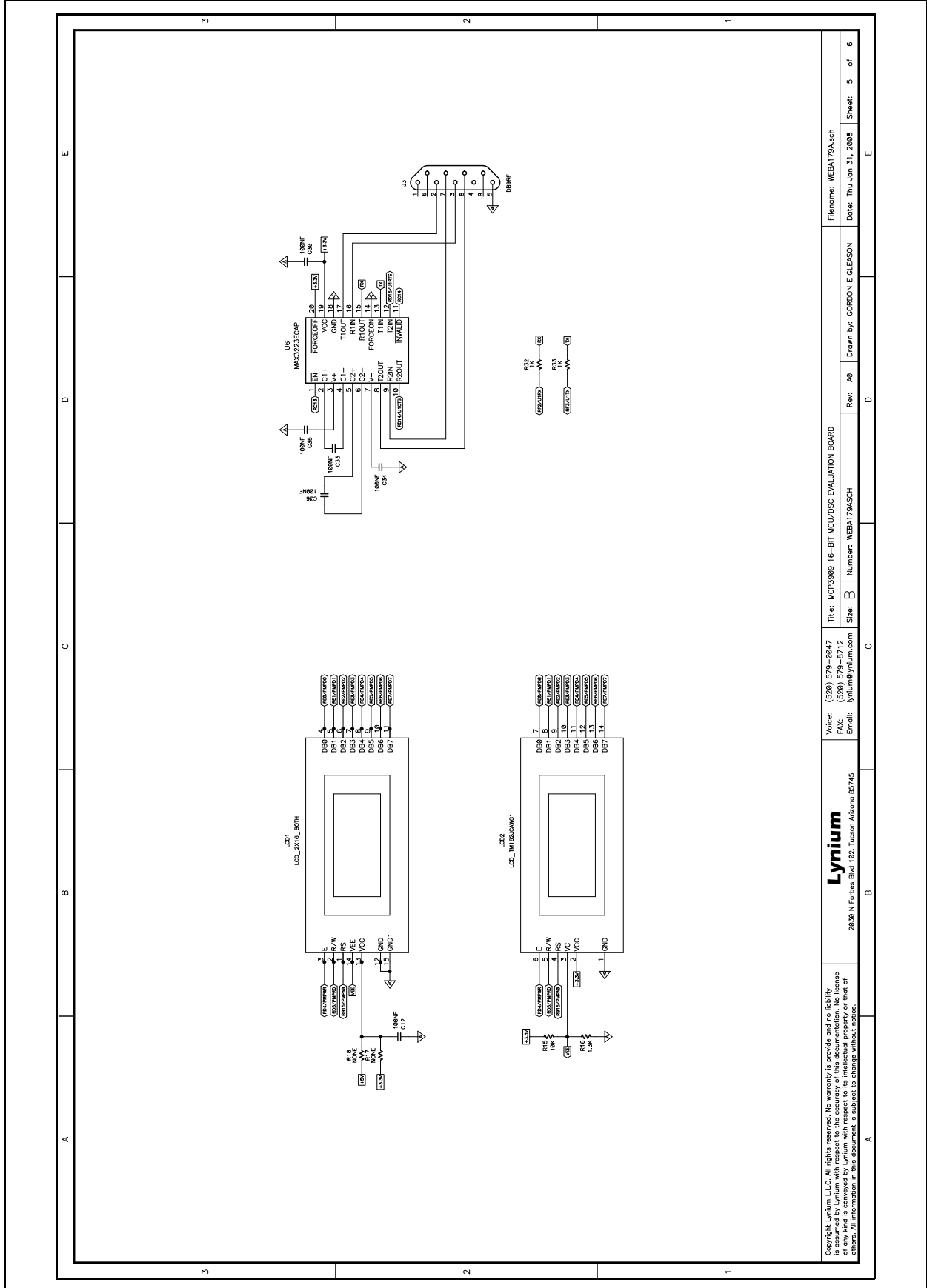

Copyright Lynium LLC. All rights reserved. No warranty is provided and no liability is assumed by Lynium with respect to the accuracy of this documentation. No license of any kind is conveyed by Lynium with respect to its intellectual property or that of others. All information in this document is subject to change without notice.

Lynium
2030 N Forth Blvd 102, Tucson Arizona 85745
Email: lynium@lynium.com

File Name: WEB179ASCH
Date: Thu Jan 31, 2008
Sheet: 5 of 6

Rev: A0
Drawn by: GORDON E GLEASON
Title: MCP3969 16-BIT MCU/DSC EVALUATION BOARD
Size: B
Number: WEB179ASCH

MCP3909 ADC Evaluation Board for 16-Bit MCUs User's Guide

A.4 SCHEMATIC - USB AND MEMORY

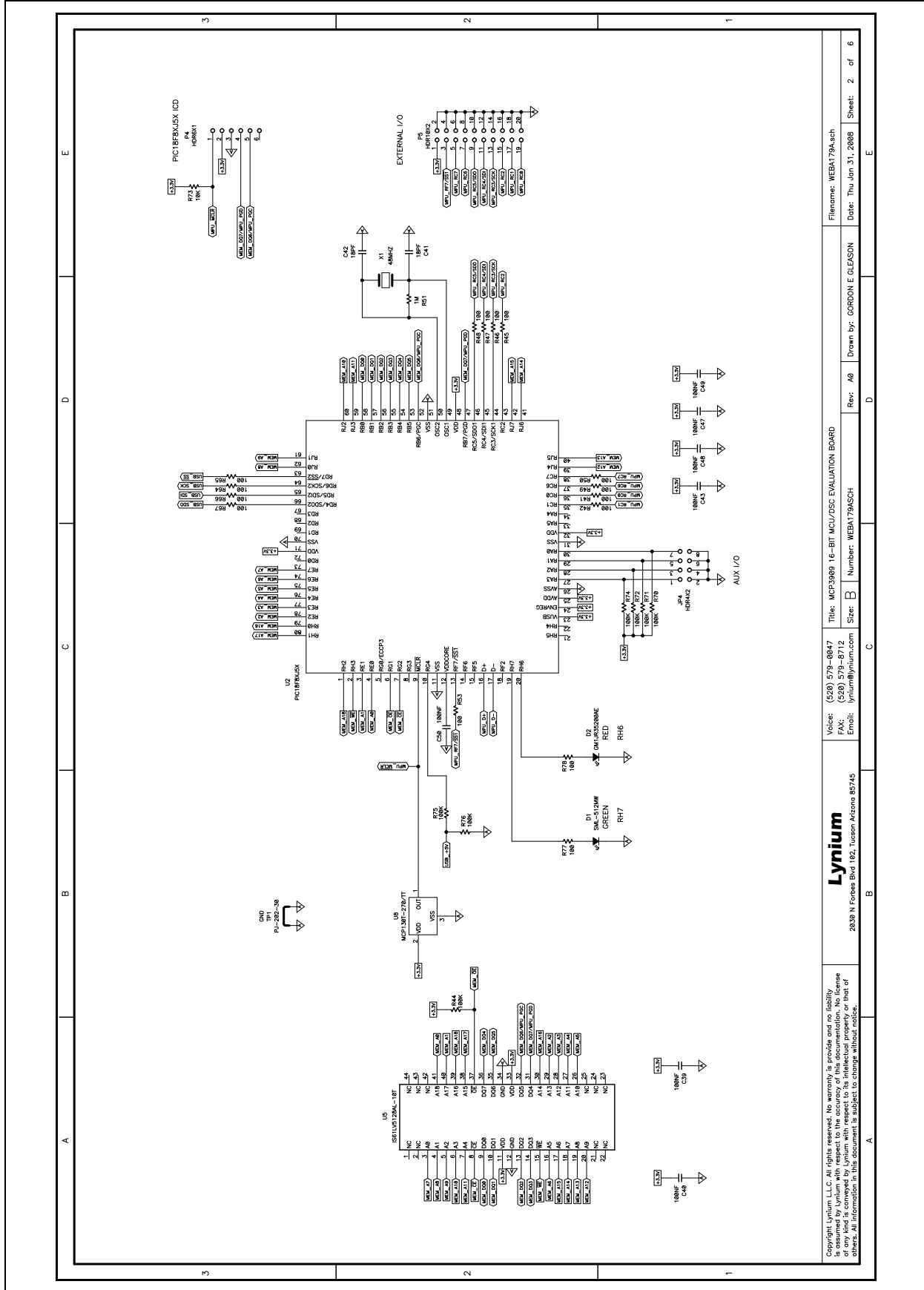

A.5 SCHEMATIC - MICROCONTROLLER (MCU)

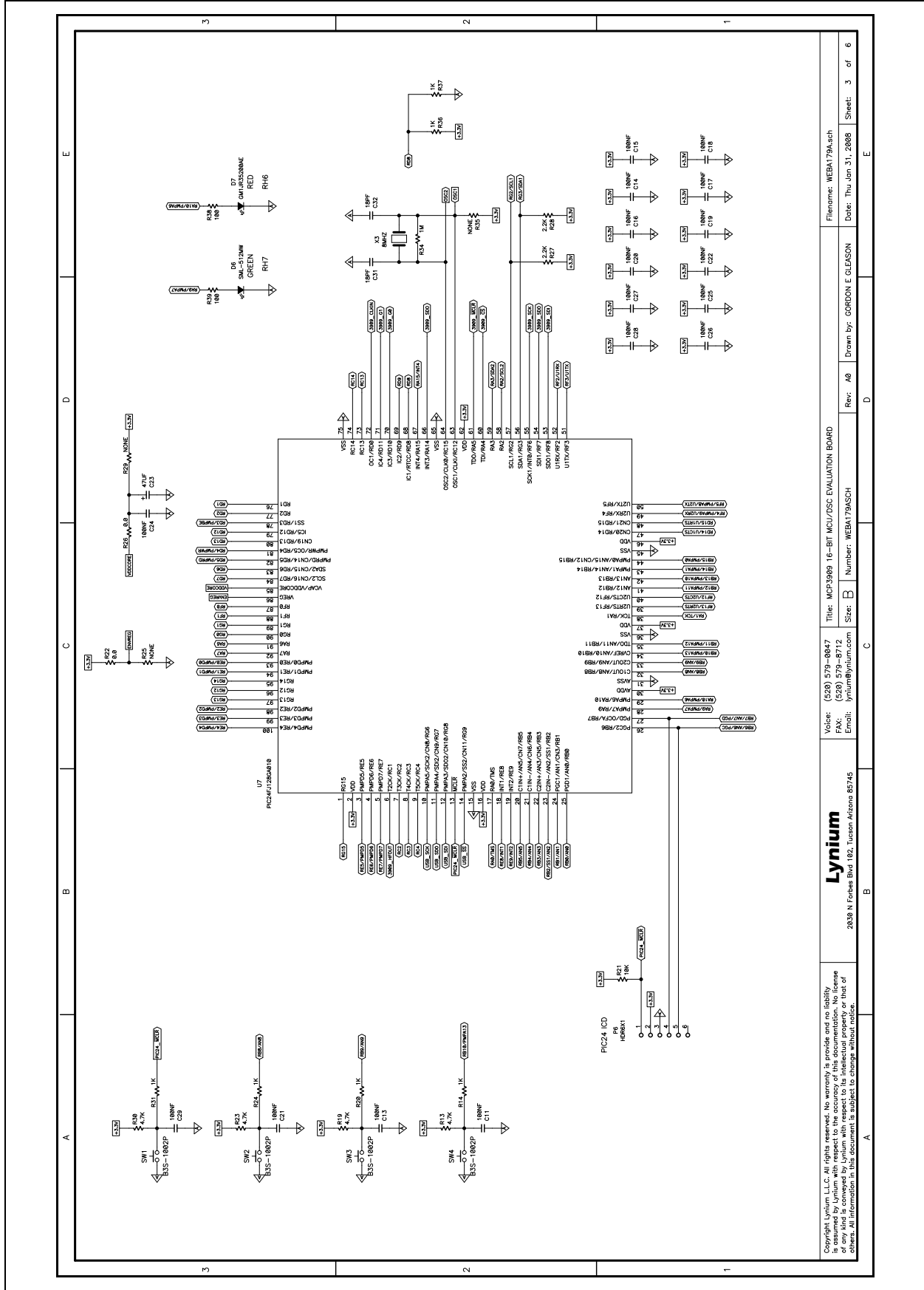

MCP3909 ADC Evaluation Board for 16-Bit MCUs User's Guide

A.6 SCHEMATIC - PIM MODULE

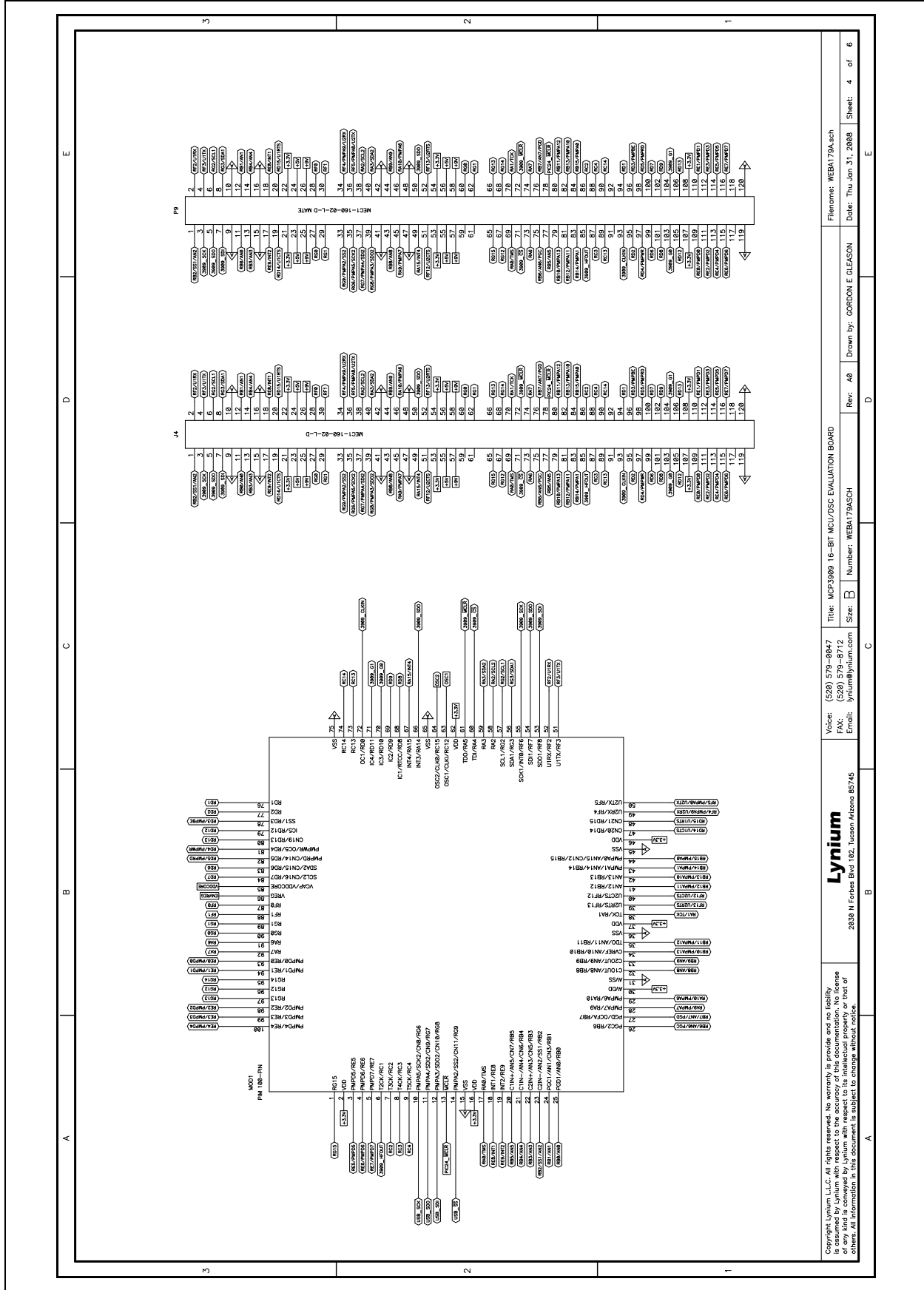

Copyright Lymium, LLC. All rights reserved. No warranty is provided, and no liability is assumed by Lymium with respect to the accuracy of this documentation. No license of any kind is conveyed by Lymium with respect to its intellectual property or that of others. All information in this document is subject to change without notice.

2030 N Forbes Blvd, #2, Tucson Arizona 85745

Lymium

Voice: (520) 575-8847
 Fax: (520) 579-8772
 Email: lym@lymnum.com

Title: MCP3909 16-BIT MCU/DSC EVALUATION BOARD
 Rev: A0
 Number: WEB4179ASCH
 Size: B

Filename: WEB4179A.sch
 Date: Thu Jan 31, 2008
 Sheet: 4 of 6

A.7 SCHEMATIC - POWER

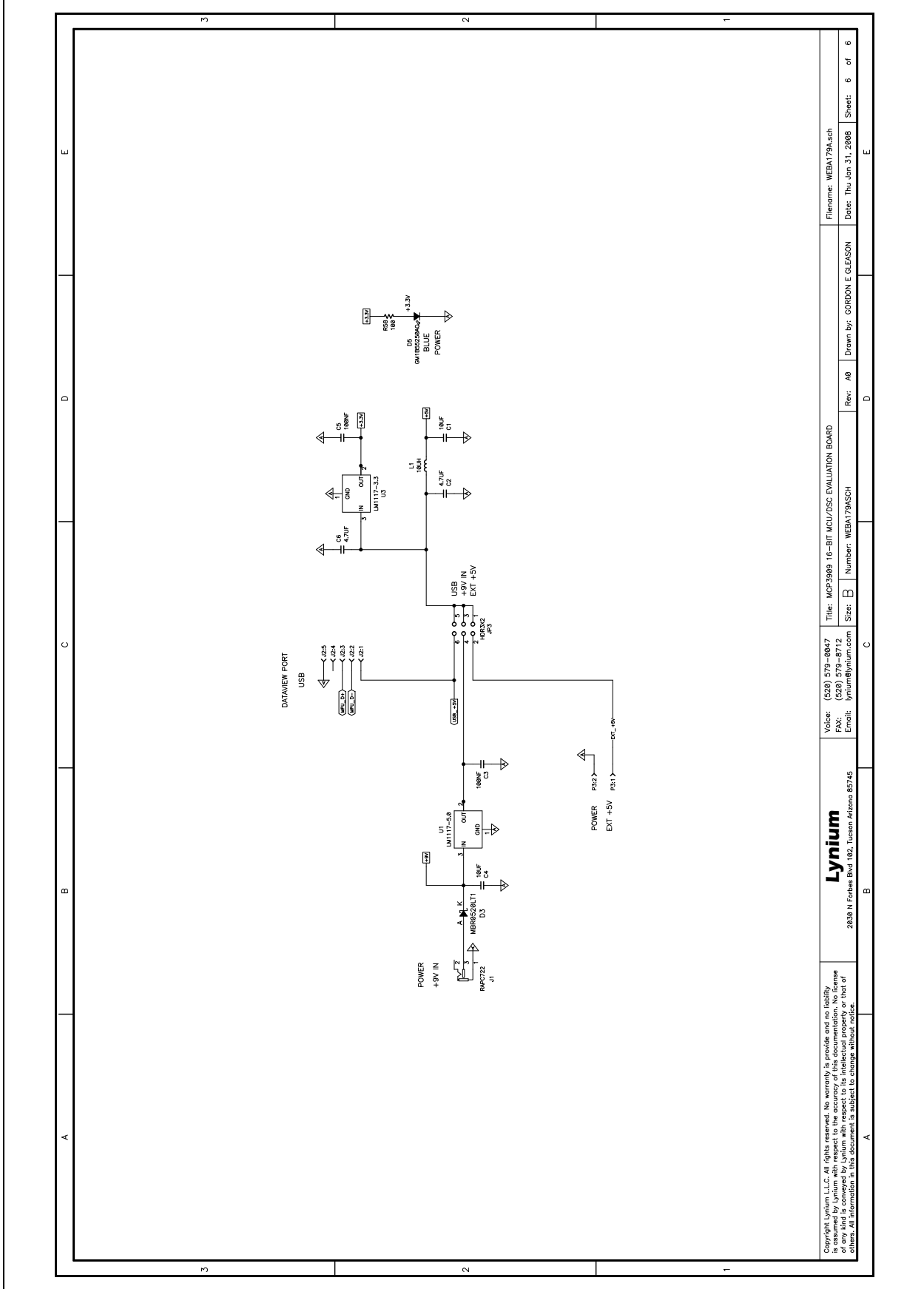

Copyright Lynium, LLC. All rights reserved. No warranty is provided, express or implied. Lynium is a trademark of Lynium with respect to the accuracy of this documentation. No license of any kind is conveyed by Lynium with respect to its intellectual property or that of others. All information in this document is subject to change without notice.	Lynium 2039 N Forbes Blvd #02, Tucson, Arizona 85745	Voice: (520) 579-8847 Fax: (520) 579-2772 Email: jynium@lynium.com	Title: MCP3989 16-BIT MCU/DSC EVALUATION BOARD Number: WEBA179ASCH Size: B	Filename: WEBA179A.sch Date: Thu Jan 31, 2008 Sheet: 6 of 6
		Rev: A9 Drawn by: GORDON E GLEASON		

MCP3909 ADC Evaluation Board for 16-Bit MCUs User's Guide

A.8 BOARD - TOP TRACE AND TOP SILK

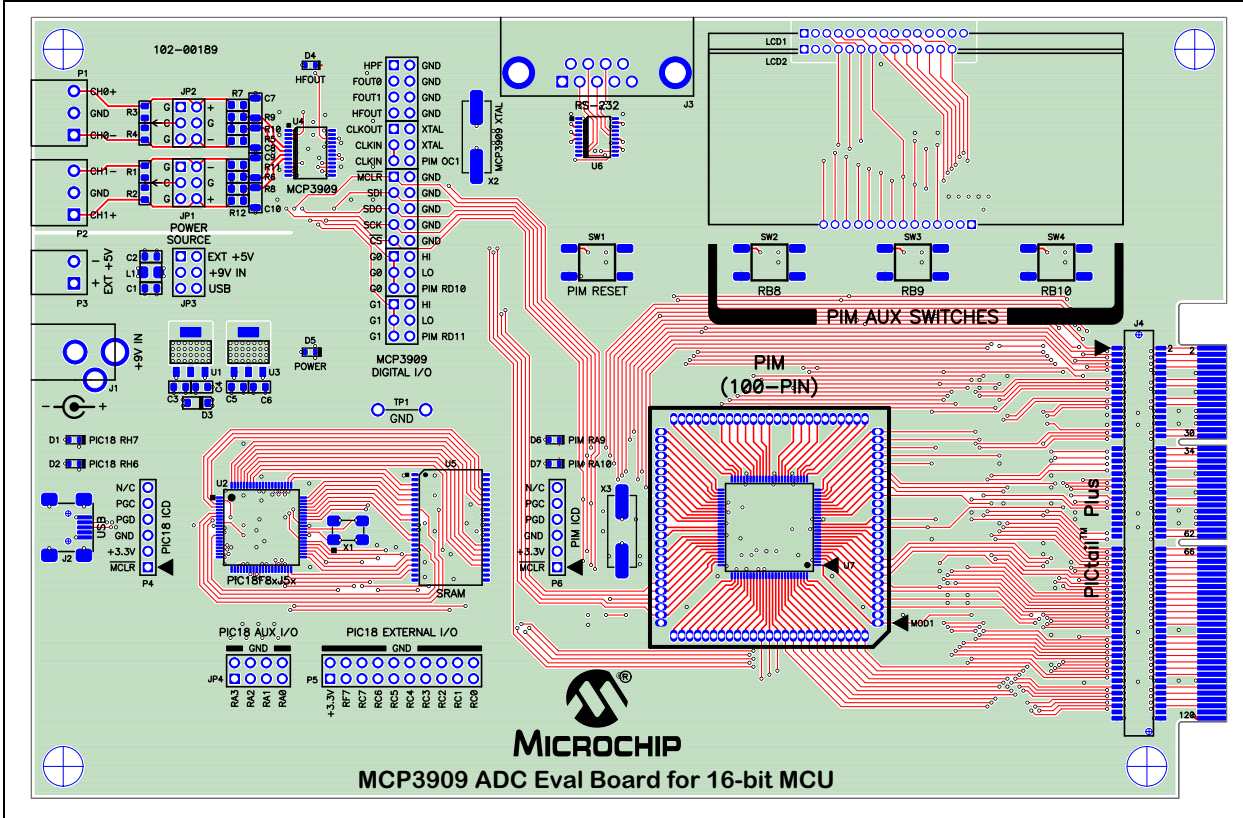

A.9 BOARD - BOTTOM TRACE AND BOTTOM SILK

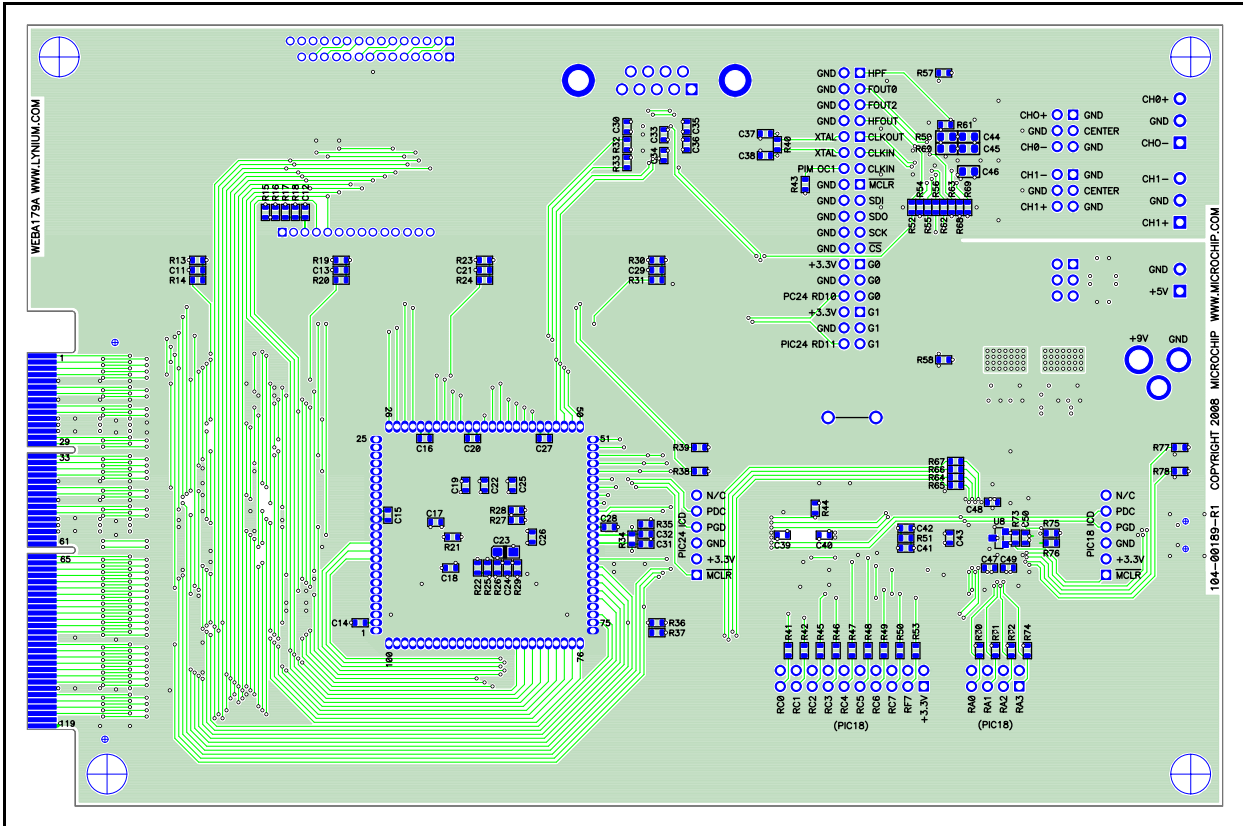

A.10 BOARD - LAYER #2 V_{DD}

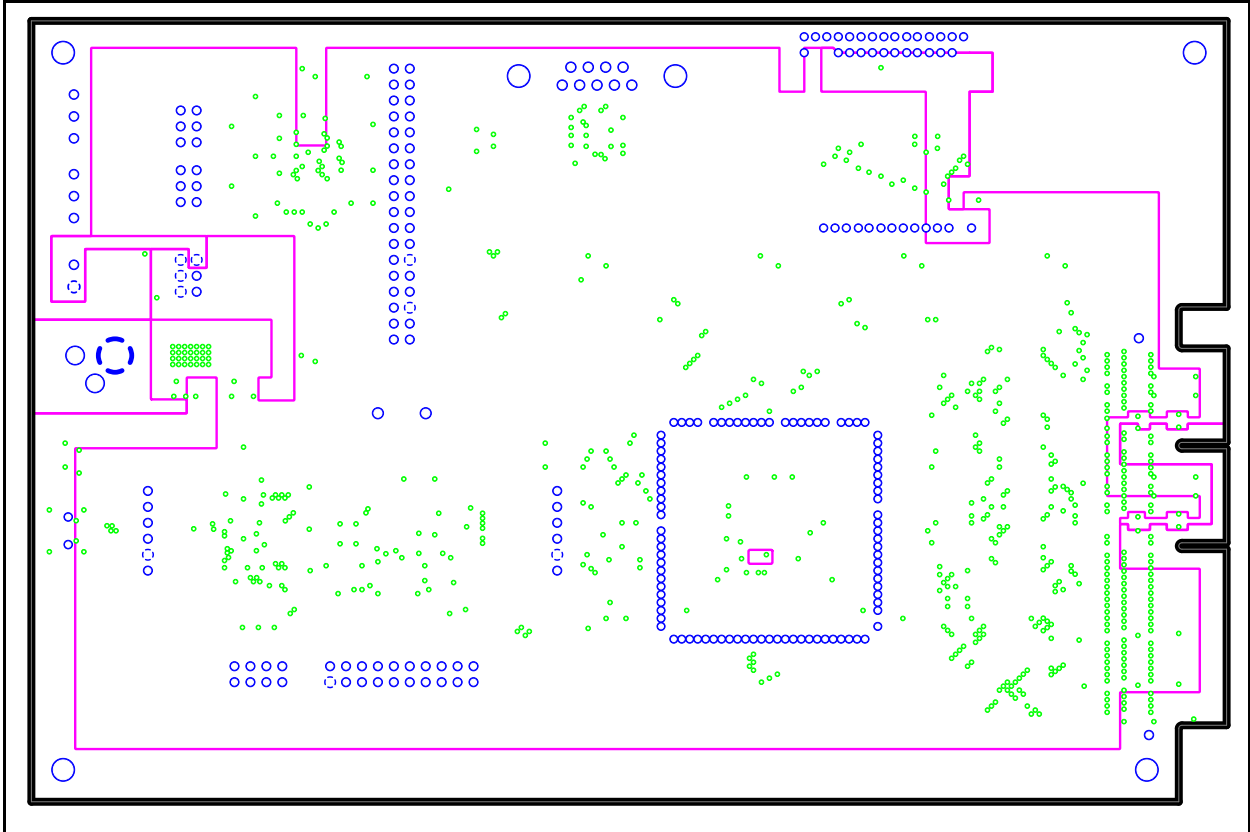

A.11 BOARD - LAYER #3 GND

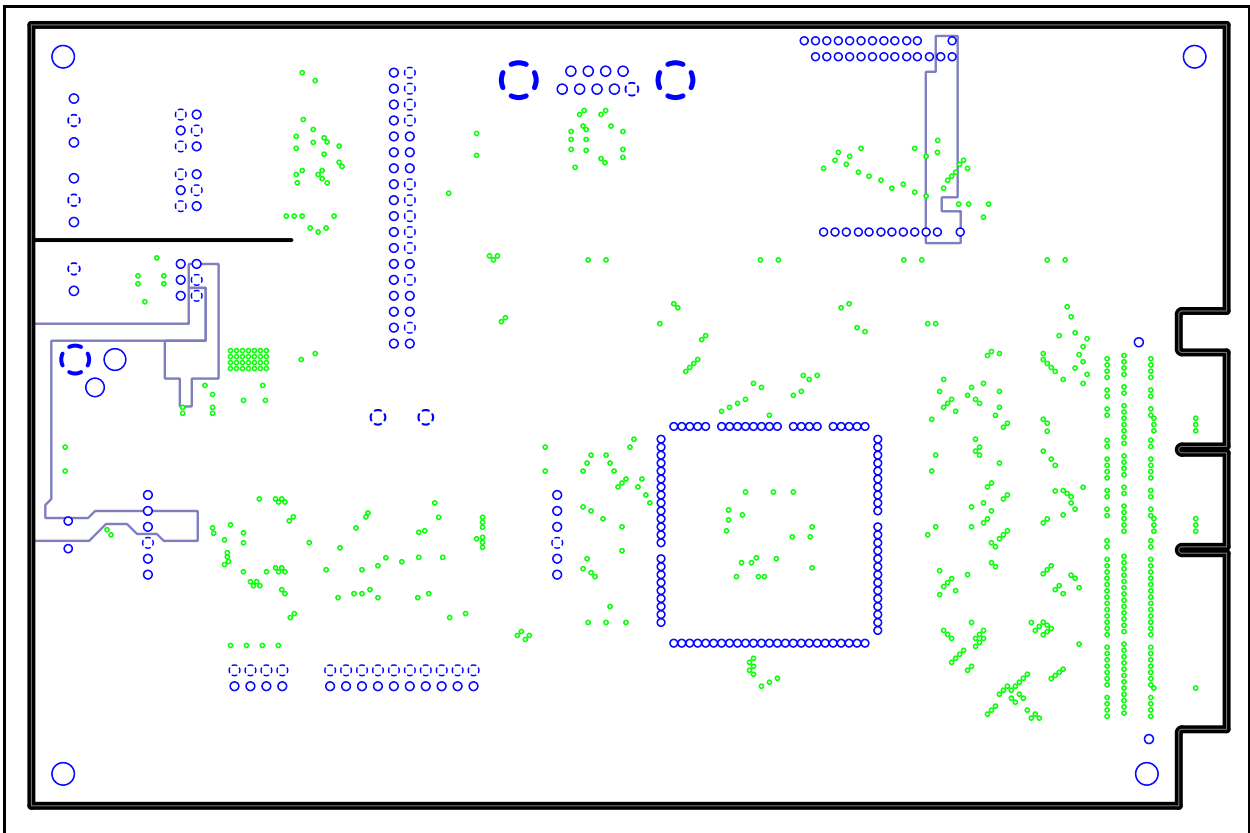

MCP3909 ADC Evaluation Board for 16-Bit MCUs User's Guide

A.12 BOARD -TOP SILK AND PADS

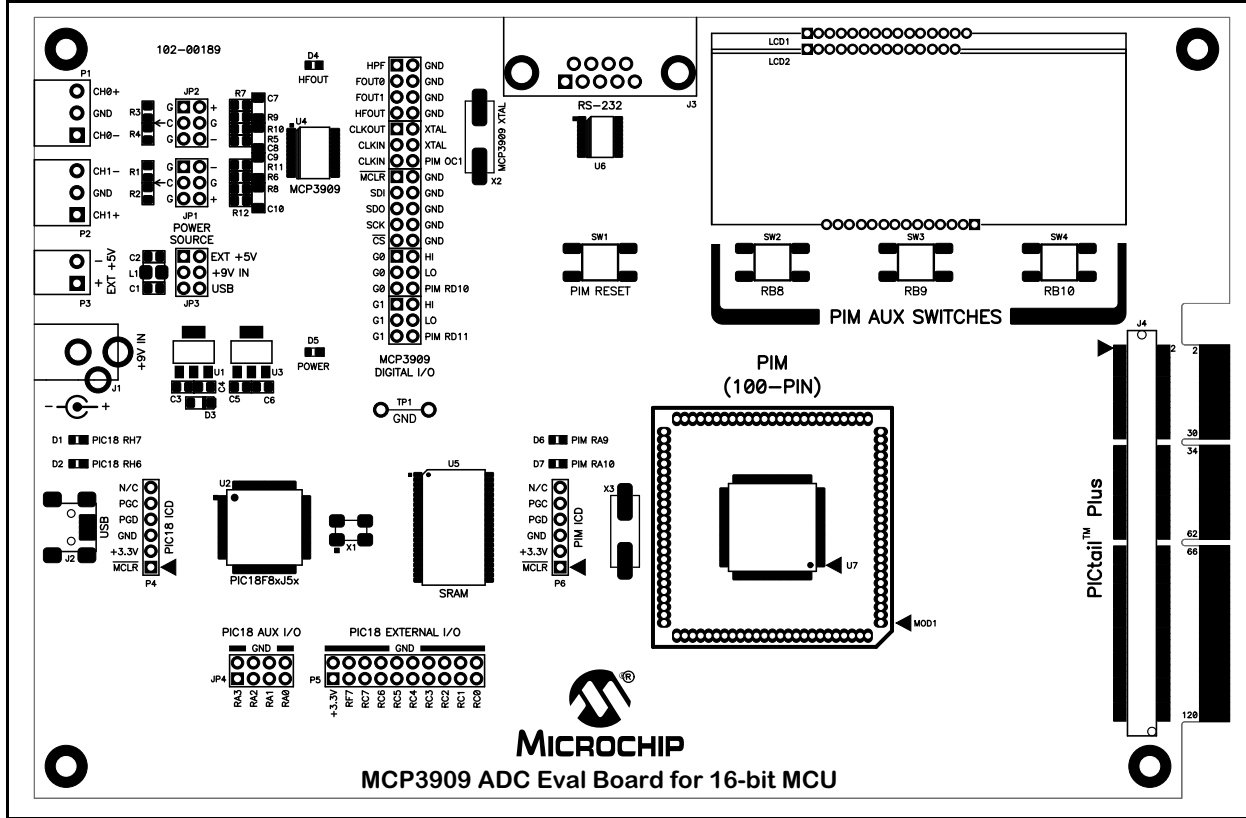

A.13 BOARD - BOTTOM SILK AND PADS

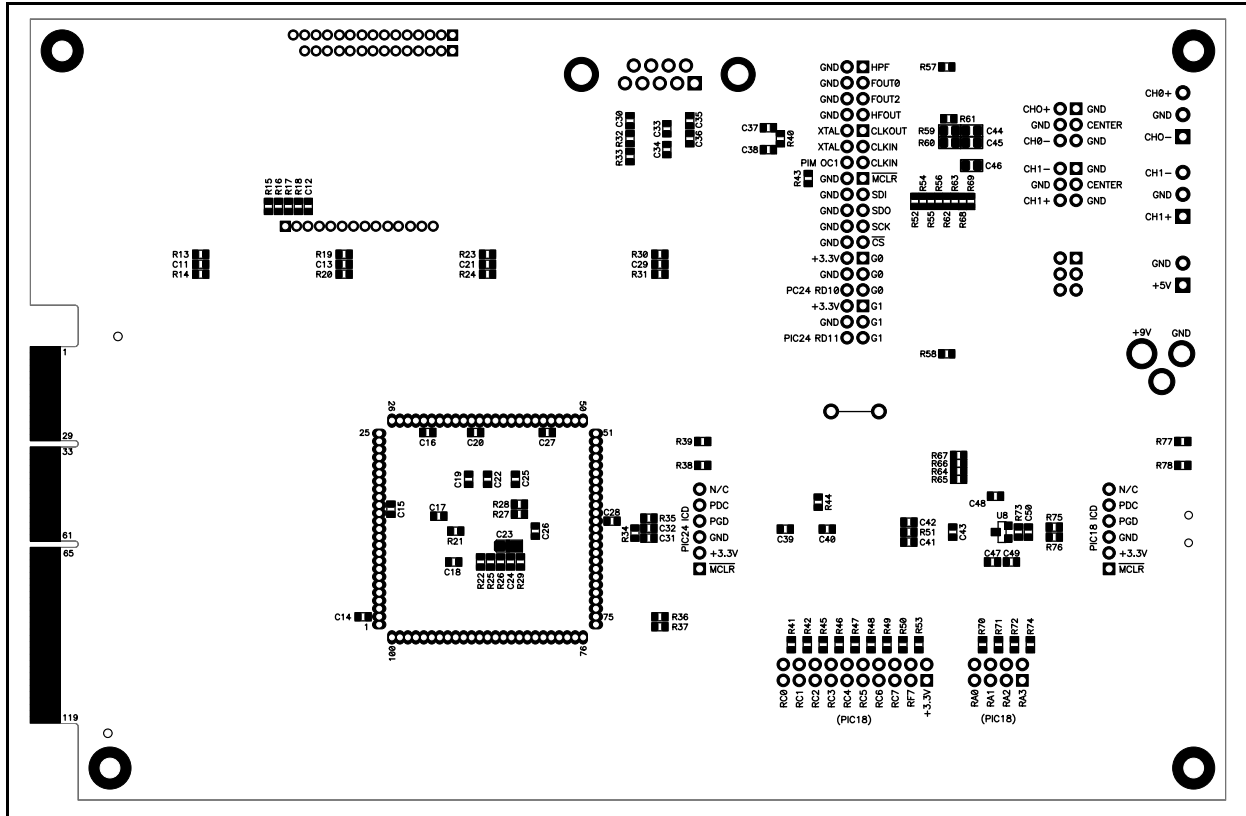

Appendix B. Bill of Materials (BOM)

TABLE B-1: BILL OF MATERIALS (BOM)

Qty	Reference	Description	Manufacturer	Part Number
2	C1, C4	CAP CER 10UF 16V X5R 0805	Murata Electronics®	GRM21BR61C106KE15L
2	C2, C6	CAP CER 4.7UF 25V X5R 0805	Murata Electronics	GRM21BR61E475KA12L
5	C3, C5, C44, C45, C46	CAP CER .1UF 25V 10% X7R 0805	Murata Electronics	GRM21BR71E104KA01L
4	C7, C8, C9, C10	CAP CER 68000PF 50V C0G 1206	Murata Electronics	GRM31C5C1H683JA01L
1	C23	CAPACITOR TANT 47UF 6.3V 20% SMD	Kemet Electronics®	T491A476M006AT
30	C11, C12, C13, C14, C15, C16, C17, C18, C19, C20, C21, C22, C24, C25, C26, C27, C28, C29, C30, C33, C34, C35, C36, C39, C40, C43, C47, C48, C49, C50	CAP CER .1UF 25V 10% X7R 0603	Murata Electronics	GRM188R71E104KA01D
6	C31, C32, C37, C38, C41, C42	CAP CER 18PF 50V 5% C0G 0603	Murata Electronics	GRM1885C1H180JA01D
2	D1, D6	LED 570NM GRN WHT/DIFF 0603 SMD	Rohm	SML-512MWT86
3	D2, D4, D7	LED RED 470NM CLEAR LENS (0603 Red)	PARA Light	L-C192KRCT-U1
1	D3	DIODE SCHOTTKY 20V 0.5A SOD123	ON Semiconductor®	MBR0520LT1G
1	D5	LED BLUE 470NM CLEAR LENS (0603 Blue)	PARA Light	L-C191LBCT-U1
1	J1	CONN POWERJACK MINI .08" R/A T/H	Switchcraft Inc.	RAPC722X
1	J2	Mini USB Type B Surface Mount	Samtec	MUSB-05-S-B-SM-A
1	J3	CONN D-SUB RCPT R/A 9POS 15GOLD	Tyco® Electronics Amp	1734354-2
1	J4	DO NOT INSTALL 120-pin MINI EDGE CARD SOCKET	Samtec	MEC1-160-02-L-D-A
3	JP1, JP2, JP3	3 X 2 Header 2.54mm on center 6 mm/2.5mm	Samtec	TSW-103-07-G-D
1	JP4	4 X 2 Header 2.54mm on center 6 mm/2.5mm	Samtec	TSW-104-07-G-D
1	JP5, JP6, JP7, P7, P8	18 X 2 Header 2.54mm on center 6 mm/2.5mm	Samtec	TSW-118-07-G-D
1	L1	Shielded 10uH Power Inductor 0805	Coilcraft	0805PS-103KLC
1	LCD1	DO NOT INSTALL	—	—
1	LCD2	16X2 FTN Reflective No. BLWT COG 3V	TianMa.	TM162JCAWG1
4	MOD1	25 X1 Header 1.27mm on center	Samtec	MTMS-125-01-G-S-230
1	P1, P2	CONN TERM BLK PLUG 6A 3.5MM 3POS	Keystone Electronics®	8723
1	P3	CONN TERM BLK PLUG 6A 3.5MM 2POS	Keystone Electronics	8722

Note 1: The components listed in this Bill of Materials are representative of the PCB assembly. The released BOM used in manufacturing uses all RoHS-compliant components.

Bill of Materials (BOM)

TABLE B-1: BILL OF MATERIALS (BOM) (CONTINUED)

Qty	Reference	Description	Manufacturer	Part Number
1	P3	TERM BLK PIN HEADER 24Pin Pos One 24 Pin Header is enough for 3 Boards	Keystone Electronics	8724
1	P5	10 X2 Header 2.54mm on center 6 mm/2.5mm	Samtec	TSW-110-07-G-D
1	P9	DO NOT INSTALL	—	—
1	PCB	RoHS Compliant Bare PCB, MCP3909 ADC Evaluation Board for 16-Bit MCUs	Microchip Technology Inc.	104-000189
13	R1, R2, R3, R4, R6, R8, R9, R10, R17, R18, R25, R29, R35	DO NOT INSTALL	—	—
4	R5, R7, R11, R12	RES 1.0K OHM .1% 1/4W 0805 SMD	Susumu Co Ltd	RGH2012-2E-P-102-B
4	R13, R19, R23, R30	RES 4.70K OHM 1/10W 1% 0603 SMD	Rohm	MCR03EZPFX4701
8	R14, R20, R24, R31, R32, R33, R36, R37	RES 1.00K OHM 1/10W 1% 0603 SMD	Rohm	MCR03EZPFX1001
4	R15, R21, R61, R73	RES 10.0K OHM 1/10W 1% 0603 SMD	Rohm	MCR03EZPFX1002
1	R16	RES 1.30K OHM 1/10W 1% 0603 SMD	Rohm	MCR03EZPFX1301
2	R22, R26	RES 0.0 OHM 1/10W 5% 0603 SMD	Rohm	MCR03EZPJ000
2	R27, R28	RES 2.20K OHM 1/10W 1% 0603 SMD	Rohm	MCR03EZPFX2201
3	R34, R40, R51	RES 1.00M OHM 1/10W 1% 0603 SMD	Rohm	MCR03EZPFX1004
28	R38, R39, R41, R42, R43, R45, R46, R47, R48, R49, R50, R52, R53, R54, R55, R56, R57, R58, R62, R63, R64, R65, R66, R67, R68, R69, R77, R78	RES 100 OHM 1/10W 1% 0603 SMD	Rohm	MCR03EZPFX1000
7	R44, R70, R71, R72, R74, R75, R76	RES 100K OHM 1/10W 1% 0603 SMD	Rohm	MCR03EZPFX1003
2	R59, R60	RES 10.0 OHM 1/8W 1% 0805 SMD	Rohm	MCR10EZH10R0
4	SW1, SW2, SW3, SW4	SWITCH TACT 6MM 230GF H=4.3MM	Omron Electronics Inc - ECB Div	B3S-1002P
1	TP1	Wire Test Point 0.3" Length	Component Corporation	PJ-202-30
1	U1	IC REG LDO 800MA 5.0V SOT-223	National Semiconductor	LM1117MP-5.0/NOPB
1	U2	IC PIC USB MCU FLASH 48KX16 80TQFP	Microchip Technology Inc	PIC18F86J55-I/PT
1	U3	IC REG LDO 800MA 3.3V SOT-223	National Semiconductor	LM1117MP-3.3/NOPB
1	U4	IC ENERGY METER 24SSOP	Microchip Technology Inc	MCP3909-I/SS
1	U5	IC SRAM 4MB ASYNC 44-TSOPII	ISSI, Integrated Silicon Solution Inc	IS61LV5128AL-10TLI
1	U6	IC DRVR/RCVR MLTCH RS232 20TSSOP	Texas Instruments	MAX3223IPWR
1	U7	DO NOT INSTALL	—	—

Note 1: The components listed in this Bill of Materials are representative of the PCB assembly. The released BOM used in manufacturing uses all RoHS-compliant components.

Bill of Materials (BOM)

TABLE B-1: BILL OF MATERIALS (BOM) (CONTINUED)

Qty	Reference	Description	Manufacturer	Part Number
1	U8	2.7V Voltage Supervisor SOT-23-3	Microchip Technology Inc	MCP130T-270I/TT
1	X1	CRYSTAL 48.0000MHZ 10PF SMD	Abrakon Corporation	ABM3B-48.000MHZ-10-1-U-T
1	X2	CRYSTAL 3.579545MHZ 18PFFUND SMD	Abrakon Corporation	ABLS-3.579545MHZ-B2-T
1	X3	CRYSTAL 8.000MHZ 18PF FUND SMD	Abrakon Corporation	ABLS-8.000MHZ-B2-T
9	Jumper Shunt	CONN JUMPER SHORTING TIN	Sullins Connector Solutions	STC02SYAN
4	Ea. Conner of PCB	STANDOFF HEX .500/4-40THR NYLON	Keystone Electronics	1902C
4	Ea. Conner of PCB	SCREW MACH PHIL 4-40X3/8 NYLON	Building Fasteners	NY PMS 440 0038 PH

Note 1: The components listed in this Bill of Materials are representative of the PCB assembly. The released BOM used in manufacturing uses all RoHS-compliant components.



WORLDWIDE SALES AND SERVICE

AMERICAS

Corporate Office

2355 West Chandler Blvd.
Chandler, AZ 85224-6199
Tel: 480-792-7200
Fax: 480-792-7277
Technical Support:
<http://support.microchip.com>
Web Address:
www.microchip.com

Atlanta

Duluth, GA
Tel: 678-957-9614
Fax: 678-957-1455

Boston

Westborough, MA
Tel: 774-760-0087
Fax: 774-760-0088

Chicago

Itasca, IL
Tel: 630-285-0071
Fax: 630-285-0075

Dallas

Addison, TX
Tel: 972-818-7423
Fax: 972-818-2924

Detroit

Farmington Hills, MI
Tel: 248-538-2250
Fax: 248-538-2260

Kokomo

Kokomo, IN
Tel: 765-864-8360
Fax: 765-864-8387

Los Angeles

Mission Viejo, CA
Tel: 949-462-9523
Fax: 949-462-9608

Santa Clara

Santa Clara, CA
Tel: 408-961-6444
Fax: 408-961-6445

Toronto

Mississauga, Ontario,
Canada
Tel: 905-673-0699
Fax: 905-673-6509

ASIA/PACIFIC

Asia Pacific Office

Suites 3707-14, 37th Floor
Tower 6, The Gateway
Harbour City, Kowloon
Hong Kong
Tel: 852-2401-1200
Fax: 852-2401-3431

Australia - Sydney

Tel: 61-2-9868-6733
Fax: 61-2-9868-6755

China - Beijing

Tel: 86-10-8528-2100
Fax: 86-10-8528-2104

China - Chengdu

Tel: 86-28-8665-5511
Fax: 86-28-8665-7889

China - Hong Kong SAR

Tel: 852-2401-1200
Fax: 852-2401-3431

China - Nanjing

Tel: 86-25-8473-2460
Fax: 86-25-8473-2470

China - Qingdao

Tel: 86-532-8502-7355
Fax: 86-532-8502-7205

China - Shanghai

Tel: 86-21-5407-5533
Fax: 86-21-5407-5066

China - Shenyang

Tel: 86-24-2334-2829
Fax: 86-24-2334-2393

China - Shenzhen

Tel: 86-755-8203-2660
Fax: 86-755-8203-1760

China - Wuhan

Tel: 86-27-5980-5300
Fax: 86-27-5980-5118

China - Xiamen

Tel: 86-592-2388138
Fax: 86-592-2388130

China - Xian

Tel: 86-29-8833-7252
Fax: 86-29-8833-7256

China - Zhuhai

Tel: 86-756-3210040
Fax: 86-756-3210049

ASIA/PACIFIC

India - Bangalore

Tel: 91-80-4182-8400
Fax: 91-80-4182-8422

India - New Delhi

Tel: 91-11-4160-8631
Fax: 91-11-4160-8632

India - Pune

Tel: 91-20-2566-1512
Fax: 91-20-2566-1513

Japan - Yokohama

Tel: 81-45-471- 6166
Fax: 81-45-471-6122

Korea - Daegu

Tel: 82-53-744-4301
Fax: 82-53-744-4302

Korea - Seoul

Tel: 82-2-554-7200
Fax: 82-2-558-5932 or
82-2-558-5934

Malaysia - Kuala Lumpur

Tel: 60-3-6201-9857
Fax: 60-3-6201-9859

Malaysia - Penang

Tel: 60-4-227-8870
Fax: 60-4-227-4068

Philippines - Manila

Tel: 63-2-634-9065
Fax: 63-2-634-9069

Singapore

Tel: 65-6334-8870
Fax: 65-6334-8850

Taiwan - Hsin Chu

Tel: 886-3-572-9526
Fax: 886-3-572-6459

Taiwan - Kaohsiung

Tel: 886-7-536-4818
Fax: 886-7-536-4803

Taiwan - Taipei

Tel: 886-2-2500-6610
Fax: 886-2-2508-0102

Thailand - Bangkok

Tel: 66-2-694-1351
Fax: 66-2-694-1350

EUROPE

Austria - Wels

Tel: 43-7242-2244-39
Fax: 43-7242-2244-393

Denmark - Copenhagen

Tel: 45-4450-2828
Fax: 45-4485-2829

France - Paris

Tel: 33-1-69-53-63-20
Fax: 33-1-69-30-90-79

Germany - Munich

Tel: 49-89-627-144-0
Fax: 49-89-627-144-44

Italy - Milan

Tel: 39-0331-742611
Fax: 39-0331-466781

Netherlands - Drunen

Tel: 31-416-690399
Fax: 31-416-690340

Spain - Madrid

Tel: 34-91-708-08-90
Fax: 34-91-708-08-91

UK - Wokingham

Tel: 44-118-921-5869
Fax: 44-118-921-5820