

REVISIONS				
P	LTR	DESCRIPTION	DATE	APVD
F2		REVISED PER ECR-22-150475	26AUG2022	RK MZ

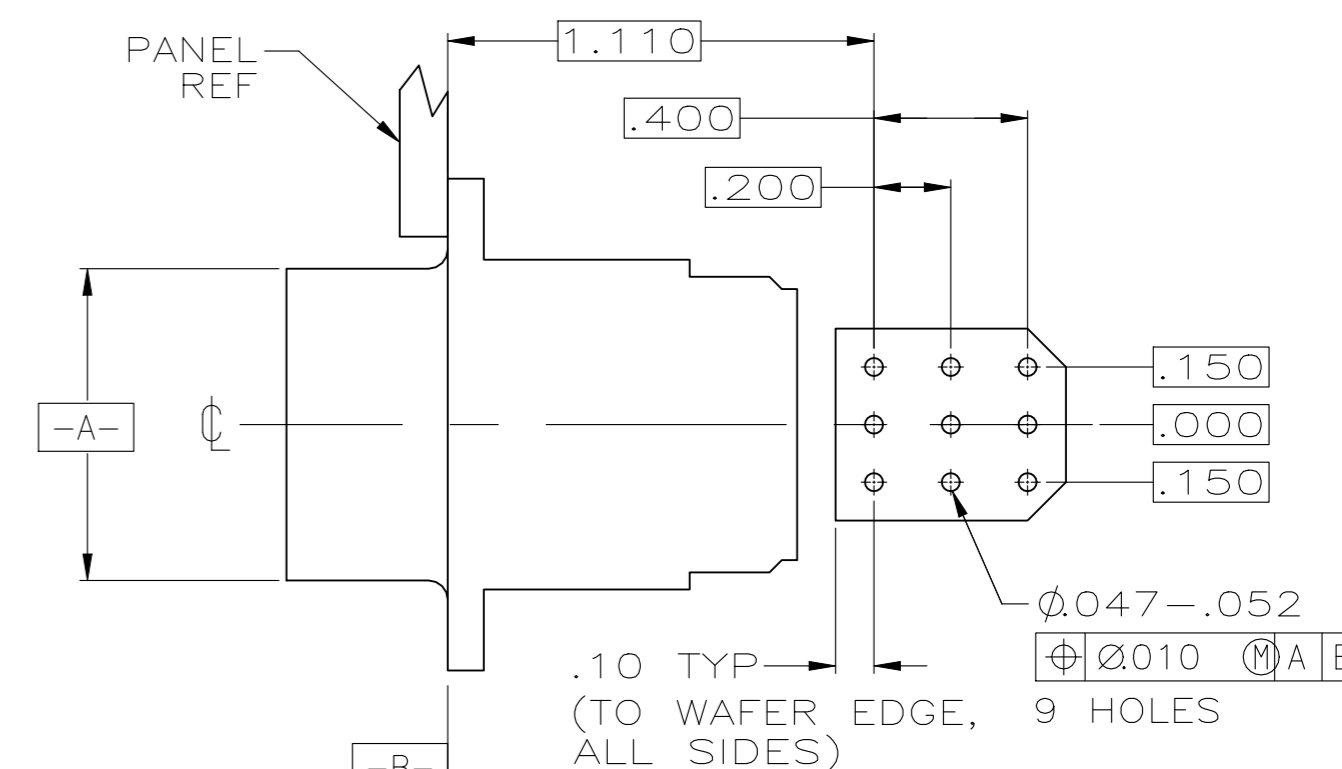

VIEW A-A Δ
RECOMMENDED PC BOARD LAYOUT

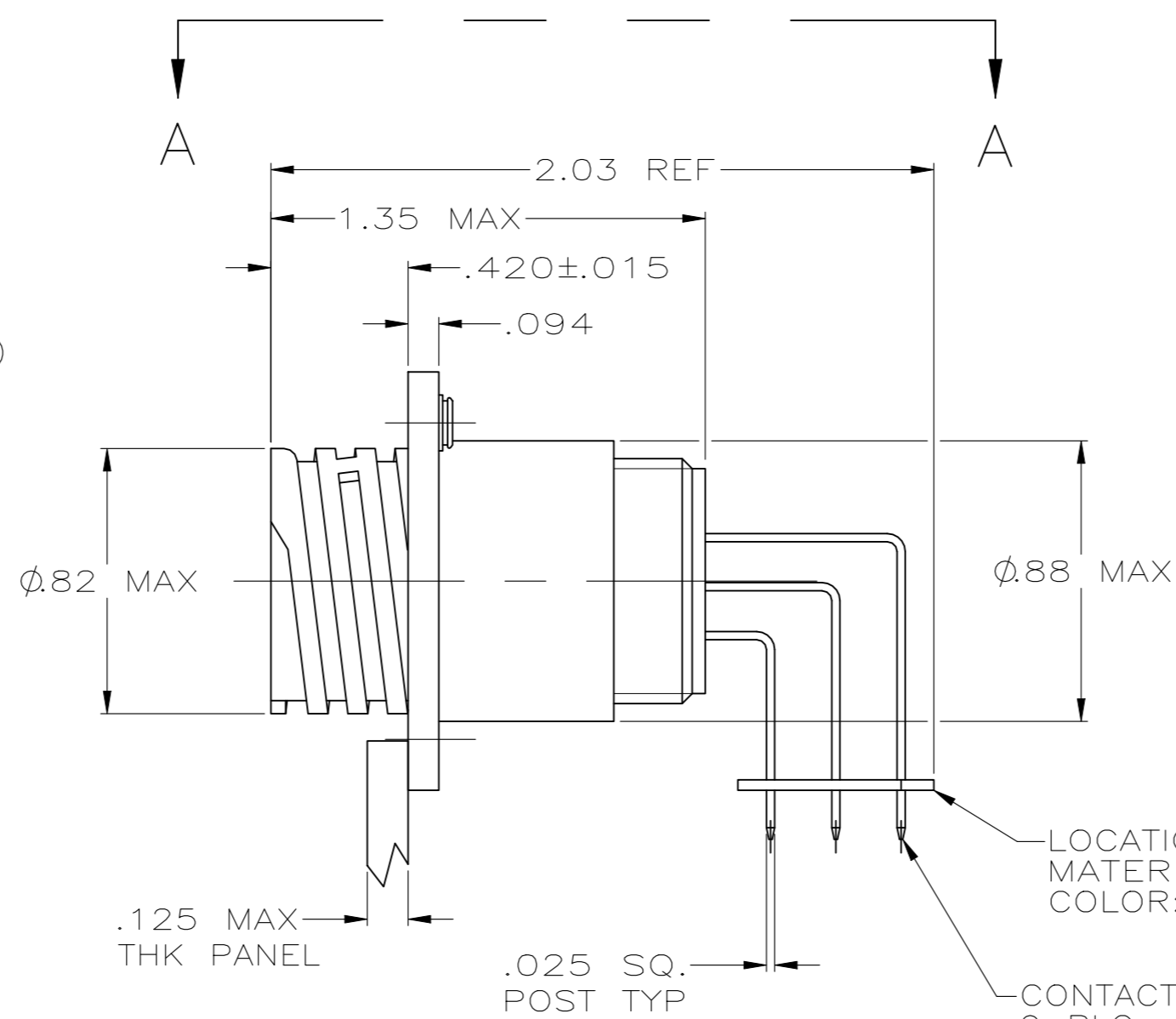
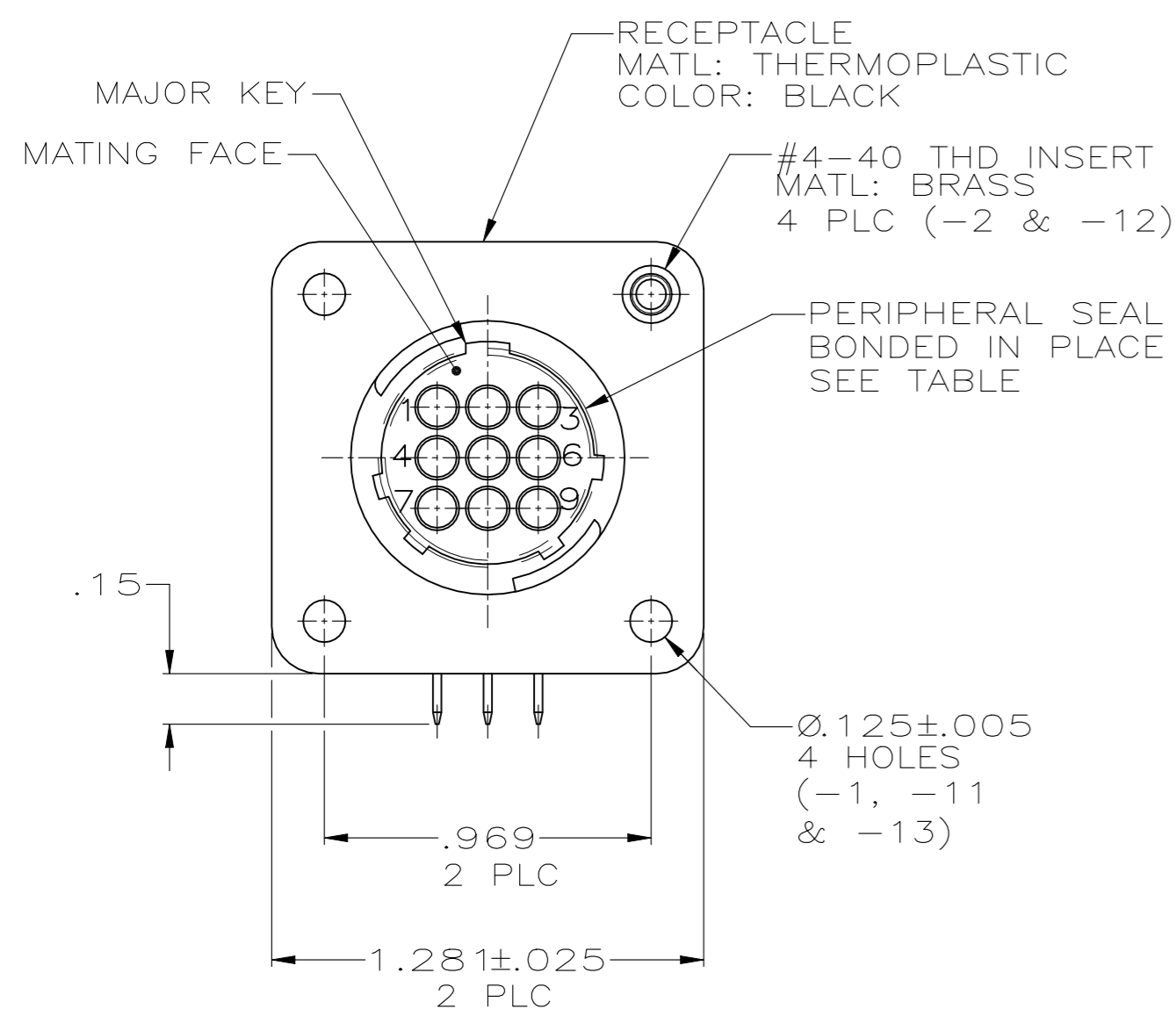
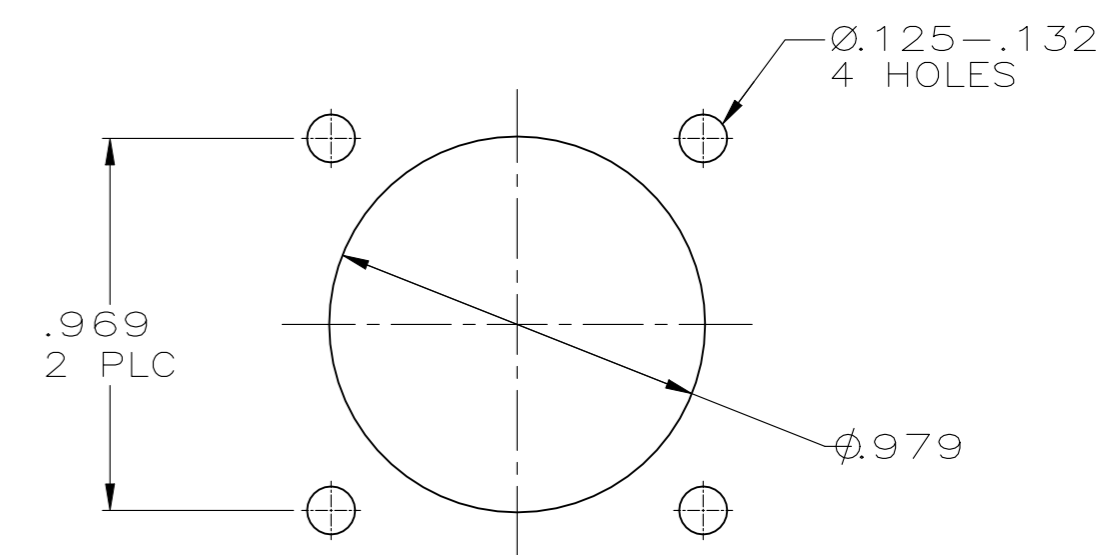

RECOMMENDED
PANEL CUTOUT

- 1 CONTACT CAVITIES IDENTIFIED BY CHARACTERS ON FRONT AND REAR FACES OF CONNECTOR.
- 2 #4 FASTENER RECOMMENDED FOR -1 MOUNTING.
#4 FASTENER REQUIRED FOR -2 MOUNTING.
- Δ 3 CONTACT BODY: .000030 MIN GOLD FOR A LENGTH OF .250 MIN FROM MATING END, WITH REMAINDER TO BE GOLD FLASH, BOTH OVER .000050 MIN NICKEL.
CONTACT POST: .000100 MIN TIN-LEAD OVER .000100 MIN COPPER.
- Δ 4 PC BOARD HOLE PATTERN IS DEFINED RELATIVE TO CONNECTOR C.L. AND PANEL MOUNTING FACE INDICATED.
- Δ 5 CONTACT BODY: .000030 MIN GOLD FOR A LENGTH OF .250 MIN FROM MATING END, WITH REMAINDER TO BE GOLD FLASH, BOTH OVER .000050 MIN NICKEL.
CONTACT POST: .000100 MIN TIN OVER .000100 MIN COPPER.

OBSOLETE	Δ 5	YES	W/O INSERTS	-1-796375-3
	Δ 5	NO	W/INSERTS	1-796375-2
	Δ 5	NO	W/O INSERTS	1-796375-1
OBSOLETE	Δ 3	YES	W/O INSERTS	-796375-3
OBSOLETE	Δ 3	NO	W/INSERTS	-796375-2
OBSOLETE	Δ 3	NO	W/O INSERTS	-796375-1
		CONTACT FINISH	SEAL	CONFIG.
				PART NUMBER

THIS DRAWING IS A CONTROLLED DOCUMENT.		DWN HAMNER 2-19-00																				
DIMENSIONS: INCHES		CHK M.CHACKO 2-23-00																				
TOLERANCES UNLESS OTHERWISE SPECIFIED:		APVD M.CHACKO 2-23-00	NAME RECEPTACLE ASSY, POSTED, RT ANGLE, STD SEX, SIZE 13-9, SERIES 1, CPC																			
<table border="1"> <tr><td>0 PLC</td><td>±</td><td>-</td></tr> <tr><td>1 PLC</td><td>±</td><td>-</td></tr> <tr><td>2 PLC</td><td>±</td><td>.03</td></tr> <tr><td>3 PLC</td><td>±</td><td>.010</td></tr> <tr><td>4 PLC</td><td>±</td><td>-</td></tr> <tr><td>ANGLES</td><td>±</td><td>-</td></tr> </table>		0 PLC	±	-	1 PLC	±	-	2 PLC	±	.03	3 PLC	±	.010	4 PLC	±	-	ANGLES	±	-	PRODUCT SPEC -	SIZE A2	
0 PLC	±	-																				
1 PLC	±	-																				
2 PLC	±	.03																				
3 PLC	±	.010																				
4 PLC	±	-																				
ANGLES	±	-																				
MATERIAL -		FINISH -	APPLICATION SPEC -	CAGE CODE 00779																		
		WEIGHT -	SCALE 2:1	DRAWING NO C=796375																		
		CUSTOMER DRAWING	SHEET 1 OF 1	RESTRICTED TO -																		
			REV F2																			