

PRODUCT DATA DRAWING

REVISION HISTORY			
REV	DESCRIPTION	DATE	APPROVED
-	NRN 45000	07/20	STW

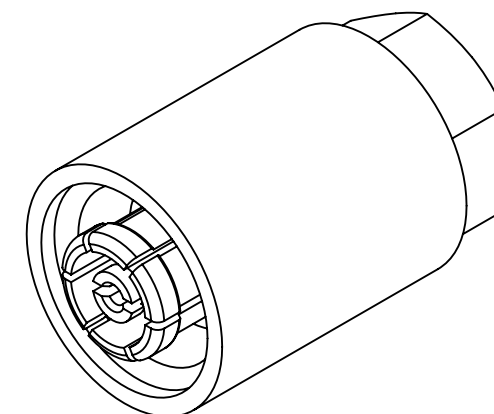
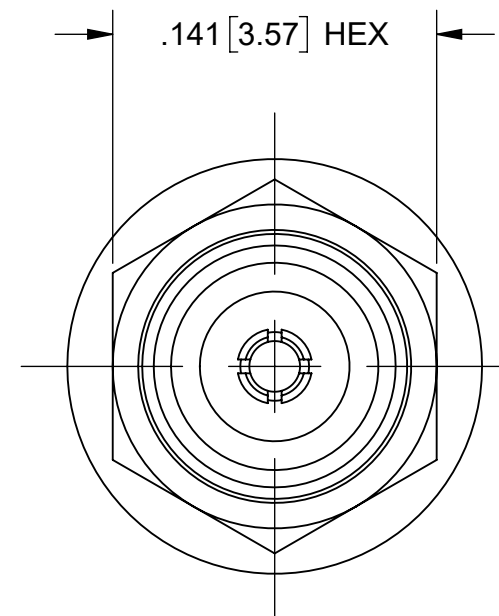
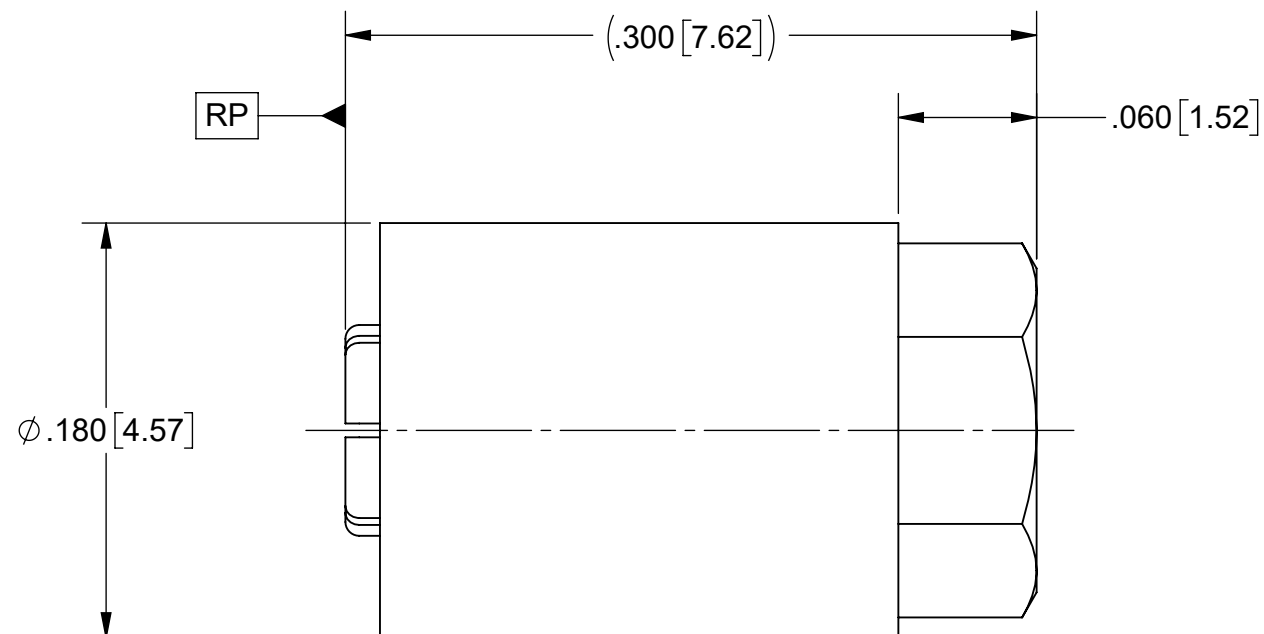

MATERIAL:

- BODY & CONTACT:** BERYLLIUM COPPER PER ASTM-B-196, ALLOY No. UNS C17300, TD04
- FERRULE:** BRASS PER ASTM B16, ALLOY UNS 36000
- INSULATOR:** PTFE PER ASTM D1710, TYPE I, GRADE 1, CLASS B
- NUT:** STAINLESS STEEL PER AMS-5640, ALLOY UNS S30300, TYPE 1 OR ASTM A582, TYPE 303

FINISH:

- BODY, FERRULE & CONTACT:** GOLD PER ASTM B488, TYPE II, CODE C, CLASS 1.27, OVER NICKEL PER AMS-QQ-N-290, CLASS 1, .00005" MIN.

- NUT:** PASSIVATED PER AMS 2700

PERFORMANCE:

- IMPEDANCE:** 50 OHMS
- FREQ. RANGE:** DC TO 40.0 GHz

MATERIAL: SEE NOTES	DIMENSIONS ARE IN INCHES TOLERANCES: FRACTIONAL: ±1/64 ANGULAR: X° ±1'0" X°X' ±15'	UNLESS OTHERWISE SPECIFIED 1) ALL DIMENSIONS ARE IN INCHES (MILLIMETERS) 2) ALL DIMENSIONS ARE AFTER PLATING. 3) BREAK CORNERS & EDGES .005 R. MAX. 4) CHAM. 1ST & LAST THREADS. 5) SURFACE ROUGHNESS 63-MIL-STD-10. 6) DIA: 'S ON COMMON CENTERS TO BE CONCENTRIC WITHIN .005 T.I.R. 7) REMOVE ALL BURRS	
FINISH: SEE NOTES	DECIMAL: X ±.030 .XX ±.010 .XXX ±.005	INTERPRET DIMENSIONS AND TOLERANCES PER ASME Y14.5M - 1994	
SURFACE AREA: N/A	THIRD ANGLE PROJECTION	DRAWN: DTL 07/20/20	TITLE: SMPM STR. FEMALE W/ RETENTION NUT FOR Ø.085 CABLE
<p>PROPRIETARY</p> <p>THE INFORMATION CONTAINED IN THIS DRAWING IS THE SOLE PROPERTY OF SV MICROWAVE, INC. ANY REPRODUCTION IN PART OR AS A WHOLE WITHOUT THE WRITTEN PERMISSION OF SV MICROWAVE, INC IS PROHIBITED.</p>		CHECKED: STW 07/20/20	SIZE DWG. NO. B 3221-60016
		APPROVED: STW 07/20/20	SCALE: 12:1 SHEET 1 OF 1