

United States Patent No. RE44,134



Precision Edge®

FEATURES

- Selects 1 of 4 differential inputs
- Provides two copies of the selected input
- Guaranteed AC performance over temperature and voltage:
 - DC-to-> 5Gbps data rate throughput
 - < 390ps IN-to-Out t_{pd}
 - < 110ps t_r / t_f times
- Ultra low-jitter design:
 - < 10ps_{PP} total jitter (clock)
 - < 1ps_{RMS} random jitter
 - < 10ps_{PP} deterministic jitter
 - < 0.7ps_{RMS} crosstalk-induced jitter
- Unique patented input design minimizes crosstalk
- Accepts an input signal as low as 100mV
- Unique patented input termination and V_T pin accepts DC- and AC-coupled inputs (CML, LVPECL, LVDS)
- 800mV 100K LVPECL output swing
- Power supply 2.5V \pm 5% or 3.3V \pm 10%
- -40°C to +85°C temperature range
- Available in 32-pin (5mm \times 5mm) MLF® package

APPLICATIONS

- Redundant clock and/or distribution
- All SONET/SDH clock/data distribution
- Loopback
- All Fibre Channel distribution
- All Gigabit Ethernet clock and/or data distribution

TYPICAL PERFORMANCE

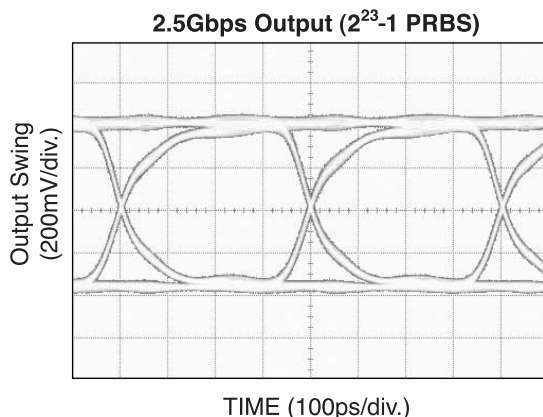

Precision Edge is a registered trademark of Micrel, Inc.
MicroLeadFrame and MLF are registered trademarks of Amkor Technology, Inc.

DESCRIPTION

The SY58029U is a 2.5V/3.3V precision, high-speed, 4:1 differential multiplexer with 100k LVPECL (800mV) compatible outputs, capable of handling clocks up to 4GHz and data streams up to 5Gbps. In addition, a 1:2 fanout buffer provides two copies of the selected inputs.

The differential input includes Micrel's unique, 3-pin input termination architecture that allows customers to interface to any differential signal (AC- or DC-coupled) as small as 100mV without any level shifting or termination resistor networks in the signal path. The result is a clean, stub-free, low-jitter interface solution. The outputs are 800mV LVPECL, (100k temperature compensated) with extremely fast rise/fall times guaranteed to be less than 110ps.

The SY58029U operates from a 2.5V \pm 5% supply or a 3.3V \pm 10% supply and is guaranteed over the full industrial temperature range of -40°C to +85°C. For applications that require CML outputs, consider the SY58028U. For 400mV LVPECL outputs, consider the SY58030U. The SY58029U is part of Micrel's high-speed, Precision Edge® product line.

All support documentation can be found on Micrel's web site at www.micrel.com.

FUNCTIONAL BLOCK DIAGRAM

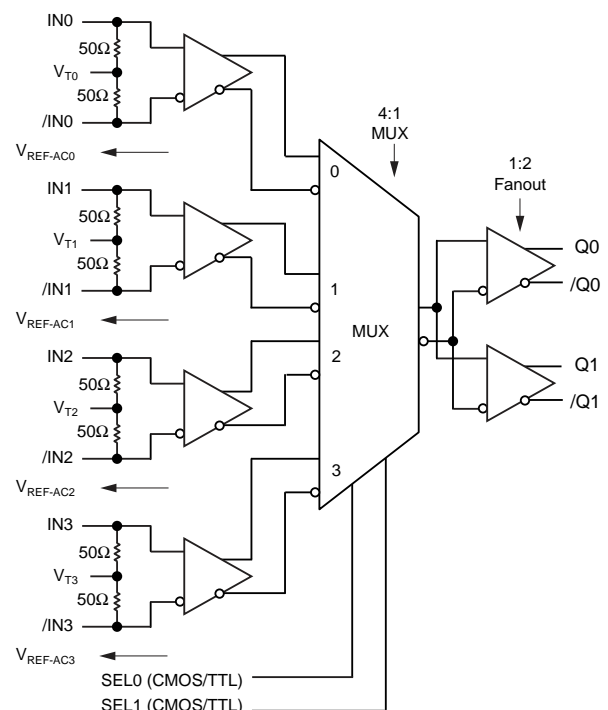

PACKAGE/ORDERING INFORMATION

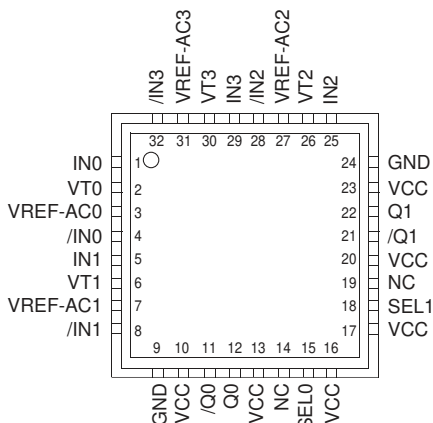

32-Pin MLF® (MLF-32)

Ordering Information⁽¹⁾

Part Number	Package Type	Operating Range	Package Marking	Lead Finish
SY58029UMI	MLF-32	Industrial	SY58029U	Sn-Pb
SY58029UMITR ⁽²⁾	MLF-32	Industrial	SY58029U	Sn-Pb
SY58029UMG ⁽³⁾	MLF-32	Industrial	SY58029U with Pb-Free bar-line indicator	Pb-Free NiPdAu
SY58029UMGTR ^(2, 3)	MLF-32	Industrial	SY58029U with Pb-Free bar-line indicator	Pb-Free NiPdAu

Notes:

1. Contact factory for die availability. Dice are guaranteed at T_A = 25°C, DC electricals only.
2. Tape and Reel.
3. Pb-Free package recommended for new designs.

PIN DESCRIPTION

Pin Number	Pin Name	Pin Function
1, 4 5, 8 25, 28 29, 32	IN0, /IN0 IN1, /IN1 IN2, /IN2 IN3, /IN3	Differential Input: Each pair accepts AC- or DC-coupled signals as small as 100mV. Each pin of a pair internally terminates to a V _T pin through 50Ω. Note that these inputs will default to an indeterminate state if left open. If an input is not used, connect one end of the differential pairs to ground through a 1kΩ resistor, and leave the other end to V _{CC} through a 825Ω resistor. Unused V _T and V _{REF-AC} pins may also be left floating. Please refer to the "Input Interface Applications" section for more details.
2, 6, 26, 30	VT0, VT1 VT2, VT3	Input Termination Center-Tap: Each side of the differential input pair terminates to a V _T pin. The V _T pin provides a center-tap to the termination network for maximum interface flexibility. See "Input Interface Applications" section for more details.
15, 18	SEL0, SEL1	This Single-Ended TTL/CMOS compatible input selects the inputs to the multiplexer. Note that this input is internally connected to a 25kΩ pull-up resistor and will default to a logic HIGH state if left open. Input logic threshold is V _{CC} /2. See "Truth Table" for select control.
14, 19	NC	No Connect.
10, 13, 16 17, 20, 23	VCC	Positive Power Supply: Bypass with 0.1μF™±0.01μF low ESR capacitors.
11, 12 21, 22	/Q0, Q0 /Q1, Q1	Differential Outputs: These 100k compatible (internally temperature compensated) LVPECL output pairs are copies of the selected input. Unused output pins may be left floating. See "Output Interface" for terminating guidelines.
9, 24	GND, Exposed Pad	Ground. Ground pin and exposed pad must be connected to the same ground plane.
3, 7, 27, 31	VREF-AC0 VREF-AC1 VREF-AC2 VREF-AC3	Reference Voltage: This reference output is equivalent to V _{CC} -1.4V. It is used for AC-coupled inputs. When interfacing to AC input signals, connect V _{REF-AC} directly to the V _T pin and bypass with 0.01μF low ESR capacitor to V _{CC} . See "Input Interface Applications" section. Maximum sink/source current is 0.5mA.

TRUTH TABLE

SEL1	SEL0	
0	0	IN0 Input Selected
0	1	IN1 Input Selected
1	0	IN2 Input Selected
1	1	IN3 Input Selected

Absolute Maximum Ratings⁽¹⁾

Power Supply Voltage (V_{CC})	-0.5V to +4.0V
Input Voltage (V_{IN})	-0.5V to V_{CC}
LVPECL Output Current (I_{OUT})		
Continuous	50mA
Surge	100mA
Termination Current ⁽³⁾		
Source or sink current on V_T pin	± 100 mA
Input Current		
Source or sink current on IN, /IN pin	± 50 mA
Lead Temperature (soldering, 20 sec.)	260°C
Storage Temperature Range (T_S)	-65°C to +150°C

Operating Ratings⁽²⁾

Power Supply Voltage (V_{CC})	+2.375V to +2.625V
	+3.0V to +3.6V
Ambient Temperature Range (T_A)	-40°C to +85°C
Package Thermal Resistance ⁽⁴⁾		
MLF® (θ_{JA})		
Still-Air	50°C/W
MLF® (ψ_{JB})		
Junction-to-Board	20°C/W

DC ELECTRICAL CHARACTERISTICS⁽⁵⁾

$T_A = -40^\circ\text{C}$ to $+85^\circ\text{C}$, unless otherwise stated.

Symbol	Parameter	Condition	Min	Typ	Max	Units
V_{CC}	Power Supply Voltage	$V_{CC} = 2.5\text{V}$	2.375	2.5	2.625	V
		$V_{CC} = 3.3\text{V}$	3.0	3.3	3.6	V
I_{CC}	Power Supply Current	No load, max. V_{CC}		110	140	mA
R_{DIFF_IN}	Differential Input Resistance (IN-to-/IN)		80	100	120	Ω
R_{IN}	Input Resistance (IN-to-/IN, /IN-to- V_T)		40	50	60	Ω
V_{IH}	Input HIGH Voltage (IN-to-/IN)	Note 6	$V_{CC}-1.6$		V_{CC}	V
V_{IL}	Input LOW Voltage (IN-to-/IN)		0		$V_{IH}-0.1$	V
V_{IN}	Input Voltage Swing (IN-to-/IN)	See Figure 1a.	0.1		1.7	V
V_{DIFF_IN}	Differential Input Voltage Swing (IN-to-/IN)	See Figure 1b.	0.2			V
V_{T_IN}	Max Input Voltage (IN-to- V_T)				1.28	V
V_{REF_AC}	Reference Voltage		$V_{CC}-1.3$	$V_{CC}-1.2$	$V_{CC}-1.1$	V

Notes:

1. Permanent device damage may occur if ratings in the "Absolute Maximum Ratings" section are exceeded. This is a stress rating only and functional operation is not implied at conditions other than those detailed in the operational sections of this data sheet. Exposure to absolute maximum ratings conditions for extended periods may affect device reliability.
2. The data sheet limits are not guaranteed if the device is operated beyond the operating ratings.
3. Due to the limited drive capability, use for input of the same package only.
4. Thermal performance assumes exposed pad is soldered (or equivalent) to the device's most negative potential (GND) on the PCB. ψ_{JB} uses 4-layer θ_{JA} in still air number unless otherwise stated.
5. The circuit is designed to meet the DC specifications shown in the above table after thermal equilibrium has been established.
6. V_{IH} (min) not lower than 1.2V.

LVPECL OUTPUT DC ELECTRICAL CHARACTERISTICS⁽⁷⁾

$V_{CC} = 2.5V \pm 5\%$ or $3.3V \pm 10\%$; $T_A = -40^\circ C$ to $+85^\circ C$; $R_L = 50\Omega$ to $V_{CC} - 2V$ across each output pair, unless otherwise stated.

Symbol	Parameter	Condition	Min	Typ	Max	Units
V_{OH}	Output HIGH Voltage		$V_{CC} - 1.145$		$V_{CC} - 0.895$	V
V_{OL}	Output LOW Voltage		$V_{CC} - 1.945$		$V_{CC} - 1.695$	V
V_{OUT}	Output Voltage Swing	See Figure 1a.	550	800		mV
V_{DIFF_OUT}	Differential Output Voltage Swing	See Figure 1b.	1100	1600		mV

LVTTTL/CMOS DC ELECTRICAL CHARACTERISTICS⁽⁷⁾

$V_{CC} = 2.5V \pm 5\%$ or $3.3V \pm 10\%$; $T_A = -40^\circ C$ to $+85^\circ C$, unless otherwise stated.

Symbol	Parameter	Condition	Min	Typ	Max	Units
V_{IH}	Input HIGH Voltage	SEL0, SEL1	2.0			V
V_{IL}	Input LOW Voltage	SEL0, SEL1			0.8	V
I_{IH}	Input HIGH Current				40	μA
I_{IL}	Input LOW Current				-300	μA

Note:

7. The circuit is designed to meet the DC specifications shown in the above table after thermal equilibrium has been established.

AC ELECTRICAL CHARACTERISTICS⁽⁸⁾

$V_{CC} = 2.5V \pm 5\%$ or $3.3V \pm 10\%$; $R_L = 50\Omega$ to $V_{CC} - 2V$; $T_A = -40^\circ C$ to $+85^\circ C$, $V_{IN} \approx 100mV$, unless otherwise stated.

Symbol	Parameter	Condition	Min	Typ	Max	Units
f_{MAX}	Maximum Operating Frequency	NRZ Data	5			Gbps
		$V_{OUT} \approx 400mV$ Clock		4		GHz
t_{pd}	Propagation Delay (Diff) (IN-to-Q) (SEL-to-Q)	$V_{IN} \approx 100mV$	215		390	ps
			100		500	ps
$t_{pd} Tempco$	Differential Propagation Delay Temperature Coefficient			115		fs/°C
t_{SKEW}	Output-to-Output	Note 9		7	15	ps
	Part-to-Part	Note 10			100	ps
t_{JITTER}	Data Random Jitter	Note 11 2.5Gbps to 3.2Gbps			1	ps_{RMS}
		Note 12 2.5Gbps to 3.2Gbps			10	ps_{PP}
	Clock Cycle-to-Cycle Jitter	Note 13			1	ps_{RMS}
		Note 14			10	ps_{PP}
	Crosstalk Induced Jitter (Adjacent Channel)	Note 15			0.7	ps_{RMS}
t_r, t_f	Output Rise/Fall Time	20% to 80%, $V_{IN} = 800mV$, full output swing	35	60	110	ps

Notes:

- 8. High frequency AC electricals are guaranteed by design and characterization.
- 9. Output-to-output skew is measured between outputs under identical input conditions.
- 10. Part-to-part skew is defined for two parts with identical power supply voltages at the same temperature and with no skew of the edges at the respective inputs.
- 11. Random jitter is measured with a K28.7 comma detect character pattern, measured at 2.5Gbps to 3.2Gbps.
- 12. Deterministic jitter is measured at 2.5Gbps to 3.2Gbps, with both K28.5 and $2^{23}-1$ PRBS pattern.
- 13. Cycle-to-cycle jitter definition: the variation of periods between adjacent cycles, $T_n - T_{n-1}$ where T is the time between rising edges of the output signal.
- 14. Total jitter definition: with an ideal clock input of frequency - f_{MAX} , no more than one output edge in 10^{12} output edges will deviate by more than the specified peak-to-peak jitter value.
- 15. Crosstalk is measured at the output while applying two similar clock frequencies that are asynchronous with respect to each other at the inputs.

SINGLE-ENDED AND DIFFERENTIAL SWINGS

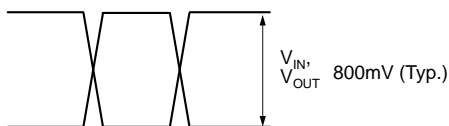

Figure 1a. Single-Ended Voltage Swing

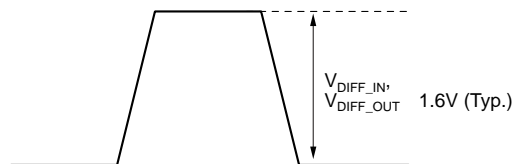

Figure 1b. Differential Voltage Swing

TIMING DIAGRAMS

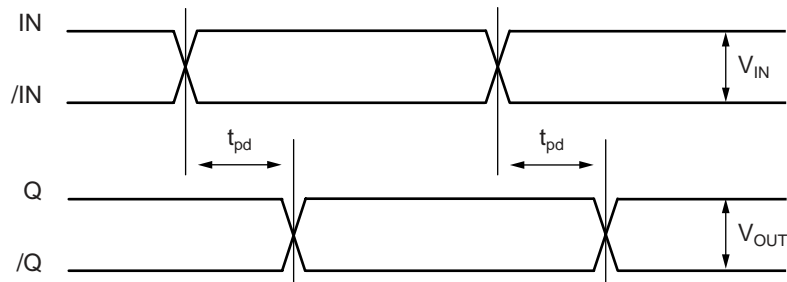

Figure 2a. IN-to-Q Timing Diagram

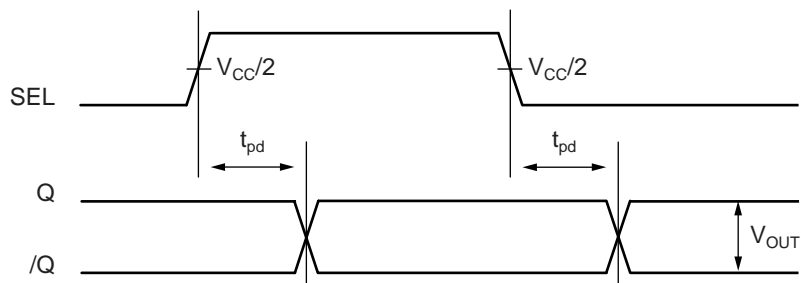
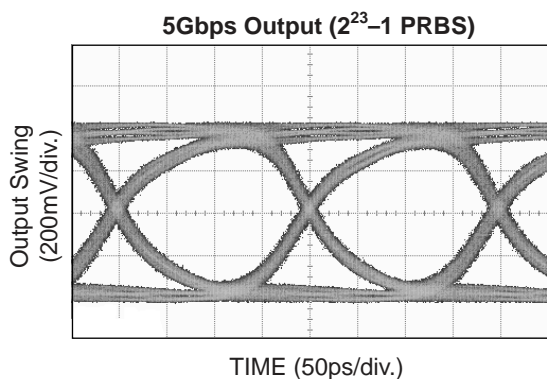
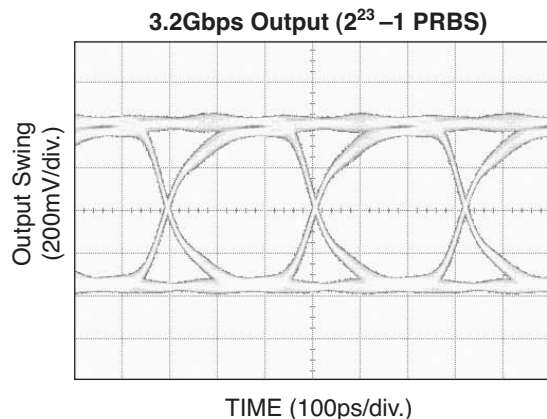
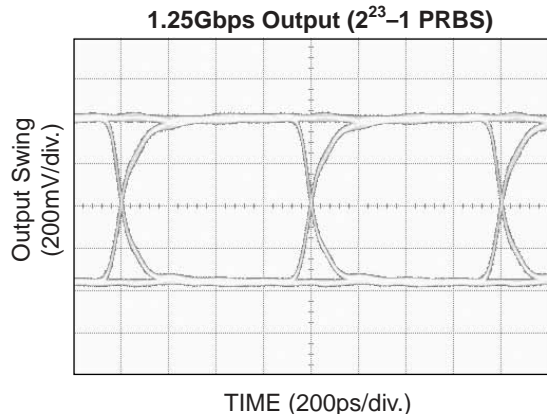
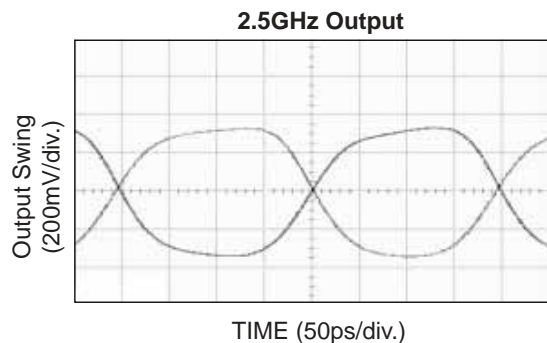
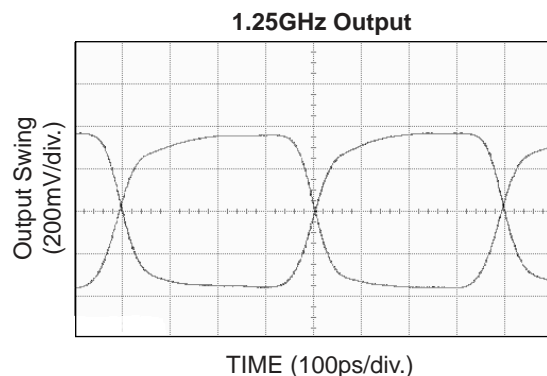
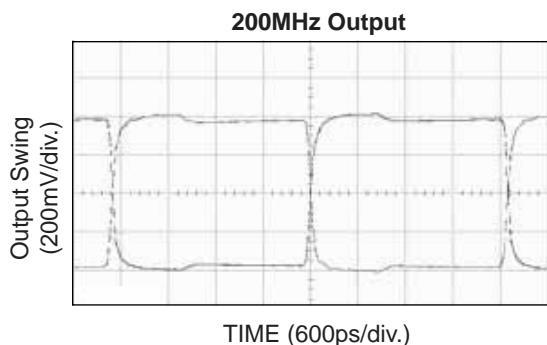

Figure 2b. SEL-to-Q Timing Diagram

- | | | | |
|---------|--------------|------------------|------------------|
| SEL0 Q: | SEL1 = LOW; | IN0, /IN1 = LOW; | /IN0, IN1 = HIGH |
| or: | SEL1 = HIGH; | IN2, /IN3 = LOW; | /IN2, IN3 = HIGH |
| SEL1 Q: | SEL0 = LOW; | IN0, /IN2 = LOW; | /IN0, IN2 = HIGH |
| or: | SEL0 = HIGH; | IN1, /IN3 = LOW; | /IN1, IN3 = HIGH |

FUNCTIONAL CHARACTERISTICS

V_{CC} = 2.5V, GND = 0, V_{IN} = 100mV, T_A = 25°C, unless otherwise stated.



TYPICAL OPERATING CHARACTERISTICS

$V_{CC} = 2.5V$, $GND = 0$, $V_{IN} = 100mV$, $T_A = 25^\circ C$, unless otherwise stated.

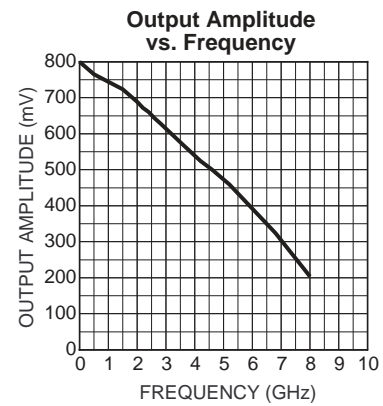
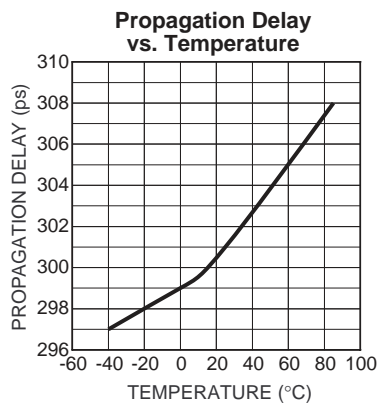
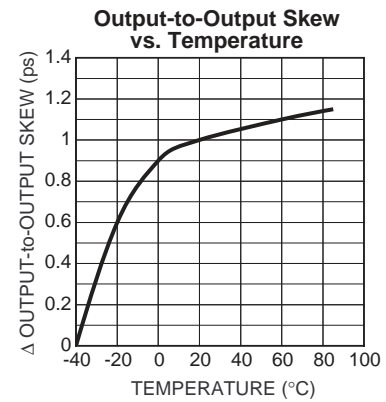
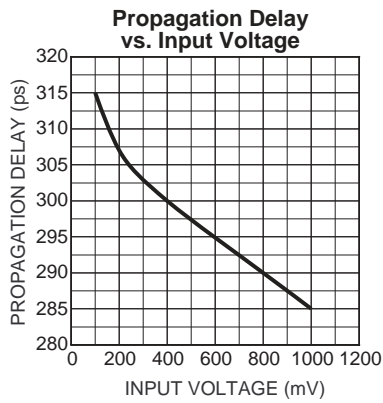

INPUT STAGE

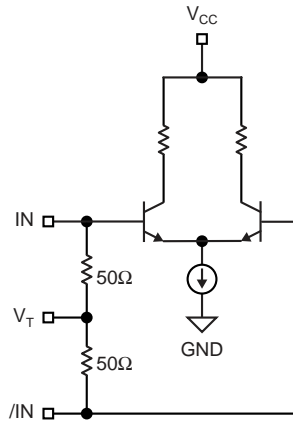

Figure 3. Simplified Differential Input Stage

INPUT INTERFACE APPLICATIONS

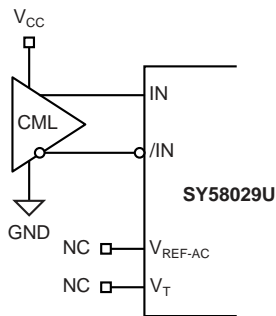

Figure 4a. CML Interface (DC-coupled)
Option: May connect V_T to V_{CC}

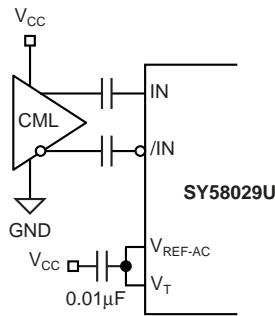

Figure 4b. CML Interface (AC-coupled)

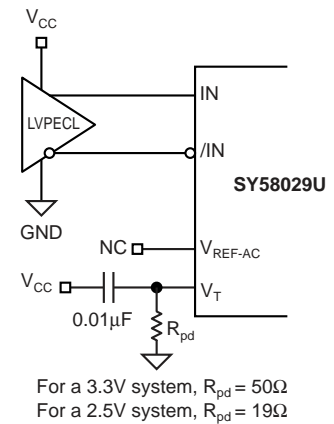

Figure 4c. PECL Interface (DC-coupled)

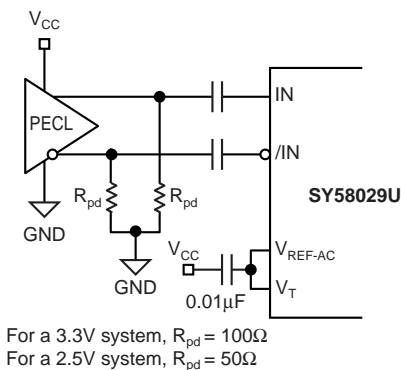

Figure 4d. LVPECL Interface (AC-coupled)

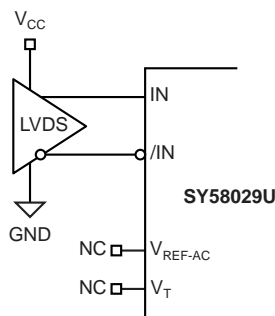

Figure 4e. LVDS Interface

OUTPUT INTERFACE APPLICATIONS

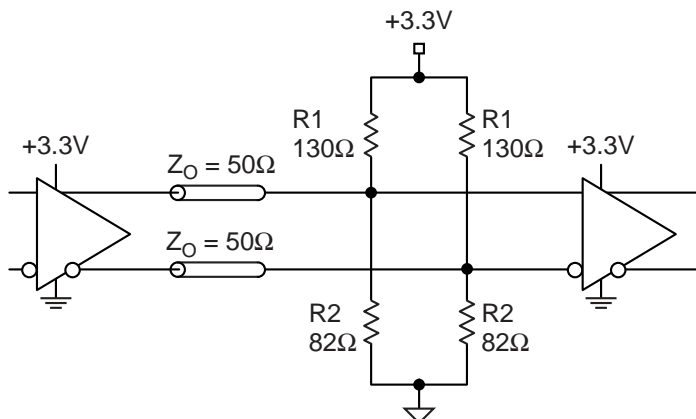

Figure 5a. Parallel Thevenin-Equivalent Termination

Note:

- 1. For a 2.5V system, R1 = 250Ω, R2 = 62.5Ω.
For a 3.3V system, R1 = 130Ω, R2 = 82Ω.

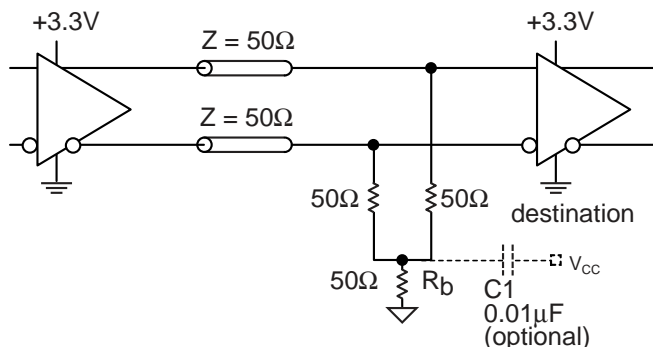

Figure 5b. Parallel Termination (Three-Resistor "Y")

Note:

- 1. For a 2.5V system, Rb = 19Ω.
For a 3.3V system, Rb = 50Ω.

RELATED MICREL PRODUCTS AND SUPPORT DOCUMENTATION

Part Number	Function	Data Sheet Link
SY58028U	Ultra Precision Differential CML 4:1 MUX with 1:2 Fanout and Internal I/O Termination	http://www.micrel.com/product-info/products/sy58028u.shtml
SY58029U	Ultra Precision Differential LVPECL 4:1 MUX with 1:2 Fanout and Internal Termination	http://www.micrel.com/product-info/products/sy58029u.shtml
SY58030U	Ultra Precision, 400mV Differential LVPECL 4:1 MUX with 1:2 Fanout and Internal Termination	http://www.micrel.com/product-info/products/sy58030u.shtml
	MLF® Application Note	www.amkor.com/products/notes_papers/MLF_AppNote_0902.pdf
HBW Solutions	New Products and Applications	www.micrel.com/product-info/products/solutions.shtml

32-PIN MicroLeadFrame® (MLF-32)

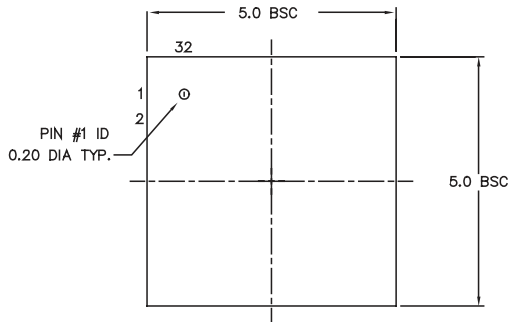

TOP VIEW

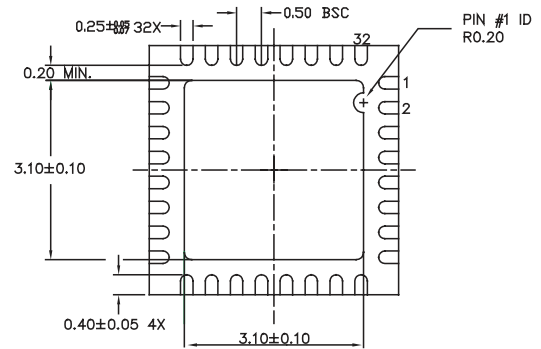

BOTTOM VIEW

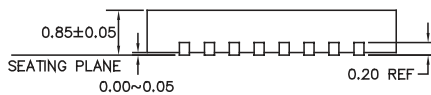

SIDE VIEW

- NOTE:
1. ALL DIMENSIONS ARE IN MILLIMETERS.
 2. MAX. PACKAGE WARPAGE IS 0.05 mm.
 3. MAXIMUM ALLOWABLE BURRS IS 0.076 mm IN ALL DIRECTIONS.
 4. PIN #1 ID ON TOP WILL BE LASER/INK MARKED.

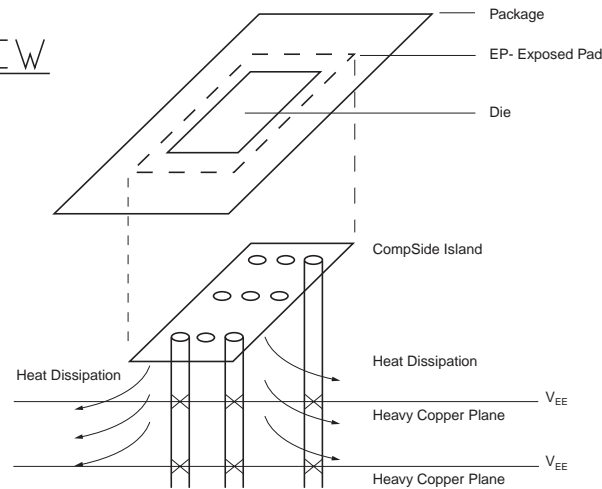

**PCB Thermal Consideration for 32-Pin MLF® Package
(Always solder, or equivalent, the exposed pad to the PCB)**

Package Notes:

1. Package meets Level 2 qualification.
2. All parts are dry-packaged before shipment.
3. Exposed pads must be soldered to a ground for proper thermal management.

MICREL, INC. 2180 FORTUNE DRIVE SAN JOSE, CA 95131 USA

TEL + 1 (408) 944-0800 FAX + 1 (408) 474-1000 WEB <http://www.micrel.com>

The information furnished by Micrel in this data sheet is believed to be accurate and reliable. However, no responsibility is assumed by Micrel for its use. Micrel reserves the right to change circuitry and specifications at any time without notification to the customer.

Micrel Products are not designed or authorized for use as components in life support appliances, devices or systems where malfunction of a product can reasonably be expected to result in personal injury. Life support devices or systems are devices or systems that (a) are intended for surgical implant into the body or (b) support or sustain life, and whose failure to perform can be reasonably expected to result in a significant injury to the user. A Purchaser's use or sale of Micrel Products for use in life support appliances, devices or systems is at Purchaser's own risk and Purchaser agrees to fully indemnify Micrel for any damages resulting from such use or sale.

© 2005 Micrel, Incorporated.