

ELECTRICAL	MECHANICAL	ENVIRONMENTAL
IMPEDANCE <u>50 Ohm</u> FREQUENCY RANGE <u>DC to 6GHz</u> INSERTION LOSS: <u>MAX. 0.05*SQRT(F) dB</u> VSWR: <u>MAX. 1.15@0-3GHz</u> <u>MAX. 1.35@3-6GHz</u> DIELECTRIC WITHSTAND VOLTAGE: <u>MAX. 2500 V RMS</u> INSULATION RESISTANCE <u>MIN. 5000 Mohms</u> PIM3: <u>MAX. -160dBc @2x20W, 900MHz, 1800MHz,</u> <u>2100MHz tested with cable</u>	MATING CYCLES: <u>MIN. 100 CYCLES</u> RECOMMENDED TORQUE: <u>5Nm</u> CABLE PULLING: <u>500N MIN.</u> CABLE TORSION: <u>5Nm MIN.</u>	TEMPERATURE RANGE: <u>-40°~+85°C</u> SALT SPRAY: <u>96H</u> INTERFACE SEAL: <u>IP68(1m, 24h) MATED</u> PANEL SEAL: <u>N/A</u>

REVISIONS					
P	LTR	DESCRIPTION	DATE	DWN	APVD

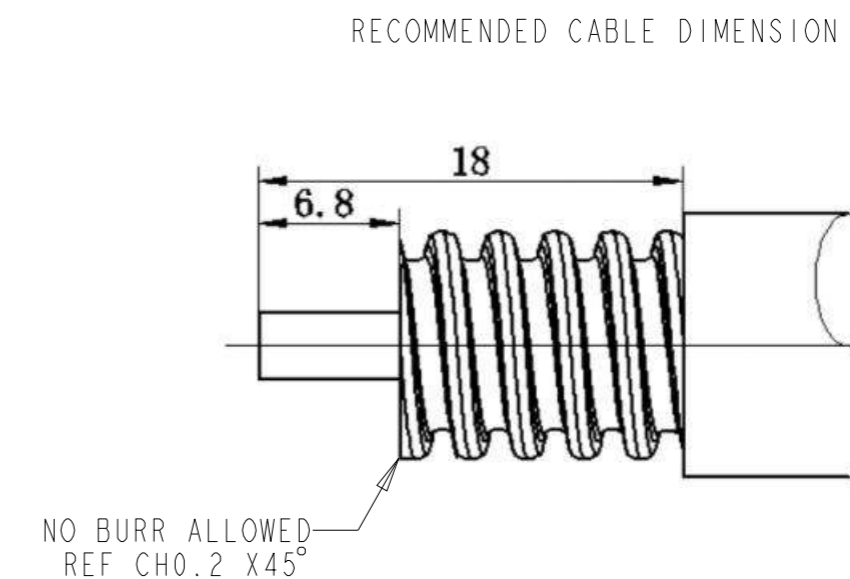
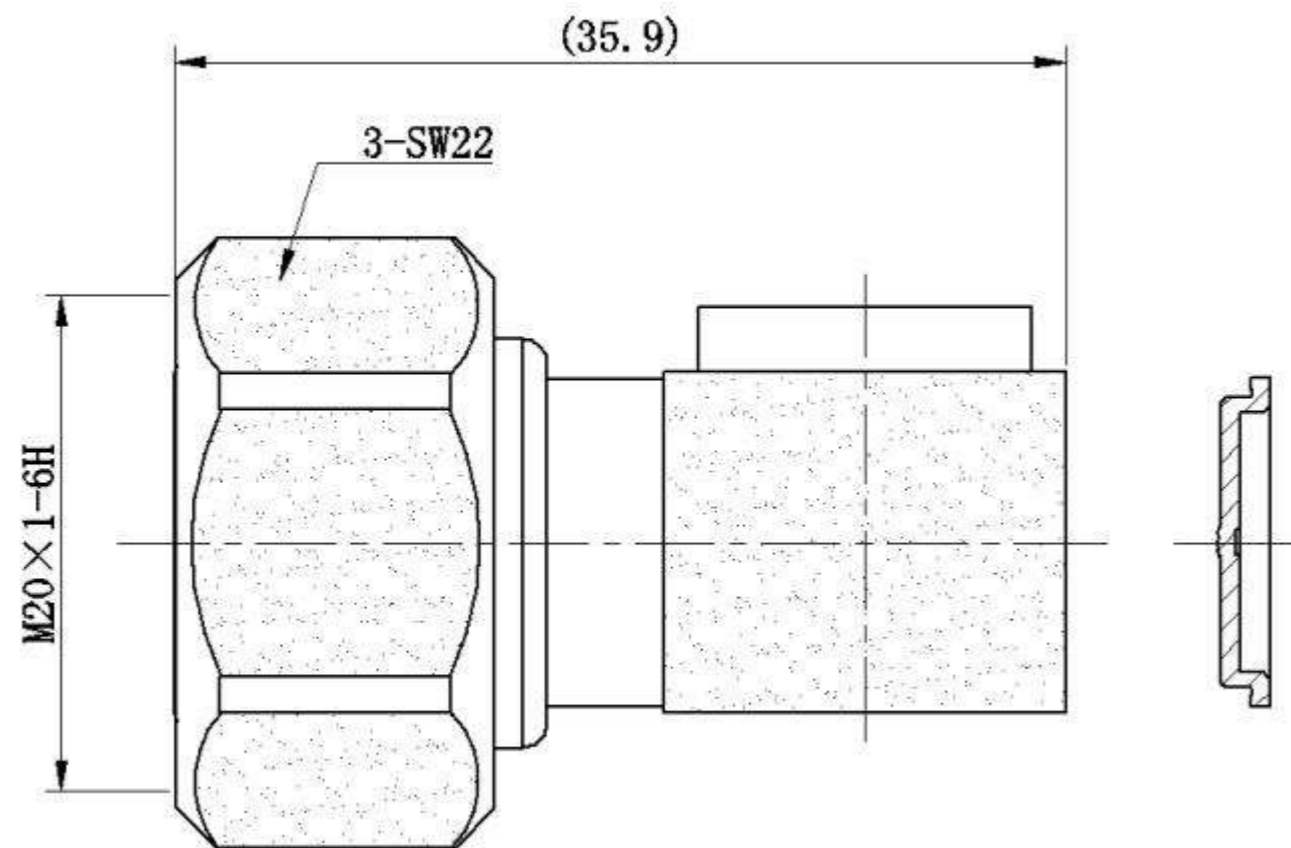

- NOTE:
1. INTERFACE ACCORDING TO IEC 61169-54
 2. CAP IS SPARE PART, AND WILL BE PACKAGED SEPARATELY.

P/N	PART NAME	MATERIAL	PLATING
2081969-1	CENTER CONTACT	BRASS	SILVER
	OUTER CONTACT	BRASS	WHITE BRONZE
	INSULATOR	PTFE	
	O-RING	SILICONE RUBBER	
	CAP	BRASS	WHITE BRONZE
	NUT	BRASS	NICKEL

THIS DRAWING IS A CONTROLLED DOCUMENT.		DWN	JZ	10MAR2020															
DIMENSIONS: mm		CHK	RZ	10MAR2020															
TOLERANCES UNLESS OTHERWISE SPECIFIED:		APVD	RS	10MAR2020															
<table border="1"> <tr><td>0 PLC</td><td>±0.3</td></tr> <tr><td>1 PLC</td><td>±0.2</td></tr> <tr><td>2 PLC</td><td>±0.2</td></tr> <tr><td>3 PLC</td><td>±0.2</td></tr> <tr><td>4 PLC</td><td>±0.2</td></tr> <tr><td>ANGLES</td><td>±</td></tr> </table>		0 PLC	±0.3	1 PLC				±0.2	2 PLC	±0.2	3 PLC	±0.2	4 PLC	±0.2	ANGLES	±	PRODUCT SPEC	108-115175	
0 PLC	±0.3																		
1 PLC	±0.2																		
2 PLC	±0.2																		
3 PLC	±0.2																		
4 PLC	±0.2																		
ANGLES	±																		
MATERIAL SEE TABLE		FINISH	SEE TABLE		APPLICATION SPEC	408-160012		SIZE	A3	CAGE CODE	00779	DRAWING NO	©-2081969	RESTRICTED TO	-				
-		-		WEIGHT	39g		CUSTOMER DRAWING			SCALE	1:1	SHEET	1 OF 2	REV	A				

REVISIONS

P	LTR	DESCRIPTION	DATE	DWN	APVD

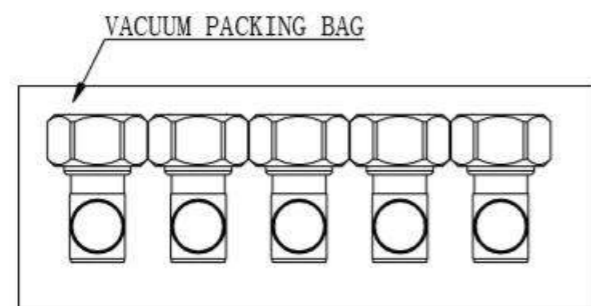

VACUUM PACKING BAG

VACUUM PACKING (5PCS/BAG)

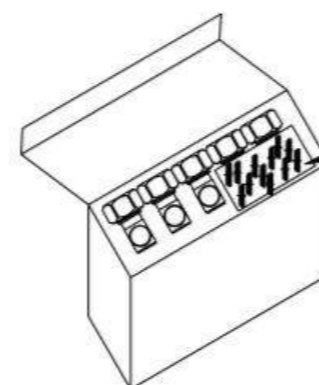

SPARE PARTS (10PCS/BAG)

INNER BOX (10PCS/BOX)

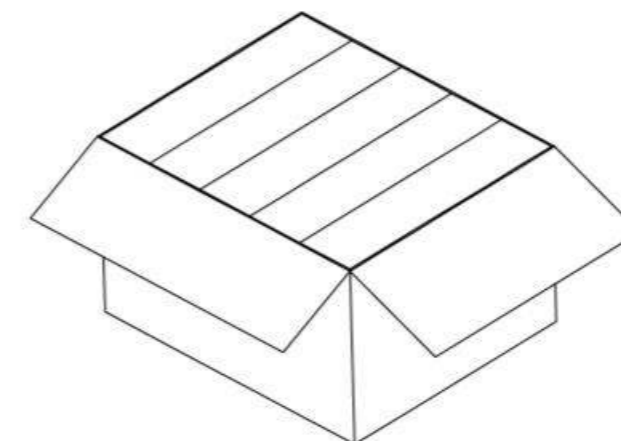

OUTER BOX (150PCS/BOX)

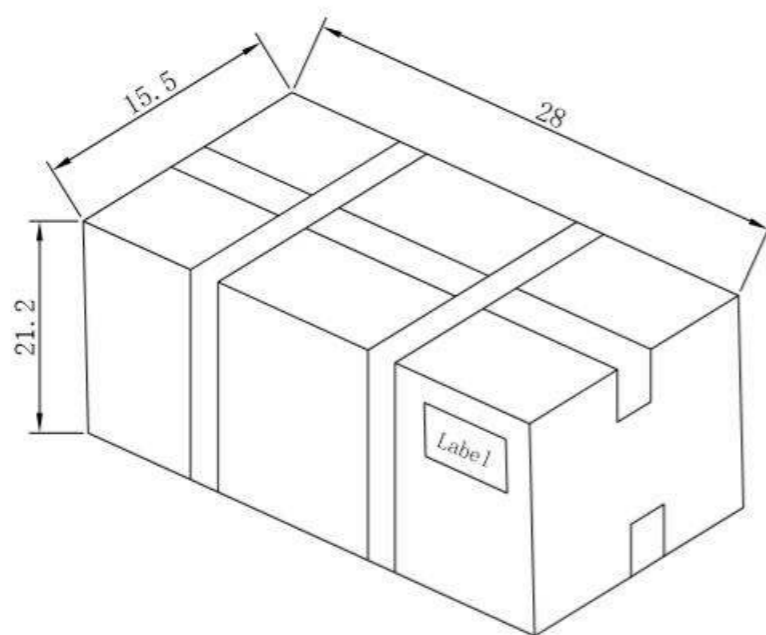

PACKAGE

(BOX SIZE ONLY FOR REFERENCE, UNIT:CM)

THIS DRAWING IS A CONTROLLED DOCUMENT.		DWN JZ	10MAR2020		
DIMENSIONS: mm		CHK RZ	10MAR2020		
TOLERANCES UNLESS OTHERWISE SPECIFIED:		APVD RS	10MAR2020	NAME 4.3-10 RA PLUG, SCREW FOR 1/2 SUPERFLEX CABLE SOLDER TYPE	
		PRODUCT SPEC 108-115175		SIZE A3	
		APPLICATION SPEC 408-160012		CAGE CODE 00779	DRAWING NO C-2081969
MATERIAL SEE TABLE		WEIGHT 39g		RESTRICTED TO -	
FINISH SEE TABLE		CUSTOMER DRAWING		SCALE 1:1	SHEET 2 OF 2
-		-		REV A	