

ROW AG & NG RECOMMENDED FOR ALL APPLICATIONS. THESE ROWS SHOULD BE CONNECTED TO GROUND.

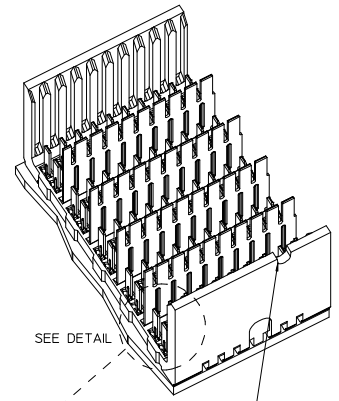

NOTCH DESIGNATES APPROX POSITION A.1.

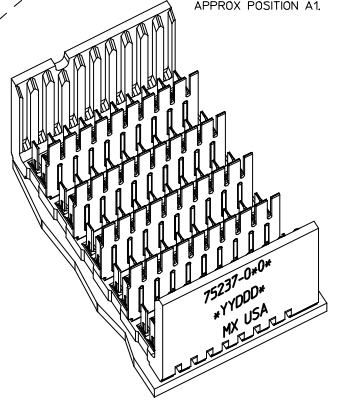
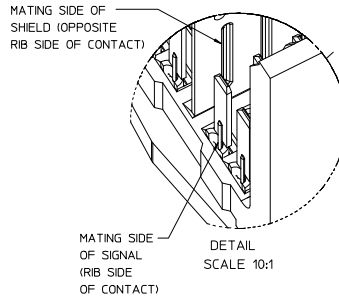
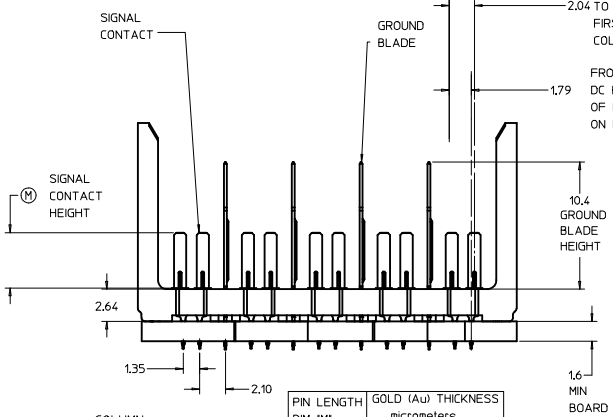
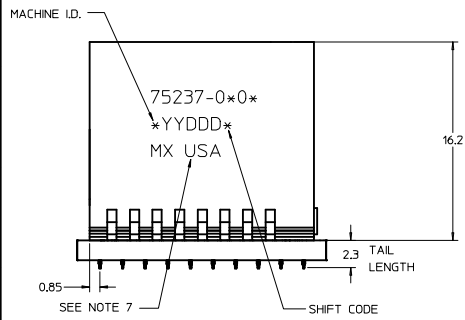

THE PRIMARY CARTON WITH A LABEL STATING "ELV AND RoHS COMPLAINT" IS LEAD FREE. CARTONS WITHOUT THIS LABEL MAY CONTAIN LEAD.

- NOTES:
1. MATERIAL: HOUSING - LIQUID CRYSTAL POLYMER (LCP) GLASS-FILLED, UL 94V-0, COLOR - BLACK, SIGNAL CONTACT AND GROUND BLADE - HIGH PERFORMANCE COPPER ALLOY.
 2. FINISHES: SELECTIVE GOLD (Au) ON CONTACT AREA, SELECTIVE MATTE TIN (Sn) ON PCB TAILS, NICKEL (Ni) OVERALL.
 3. THIS PART CONFORMS TO MOLEX PRODUCT SPECIFICATION PS-75221-999.
 4. FOR MIXED CONTACT MATING LENGTHS CONSULT MOLEX FOR AVAILABILITY. CONTACT PAIRS MUST BE THE SAME LENGTH.
 5. FOR SPECIFIC PART NUMBER AND MATING INFORMATION PLEASE REFER TO CHART.
 6. PACKAGE PER PK-70873-565.
 7. EITHER MARK PART NUMBER AND DATE CODE APPROXIMATELY WHERE SHOWN, ON EITHER SIDE OF THE PART OR PLACE A LABEL ON THE TUBE
 8. MAPS (MOLEX ADVANCED PLATING SYSTEM).

PIN LENGTH DIM "M"	GOLD (Au) THICKNESS micrometers
0=3.55 mm	0.25 (MAPS)
1=4.55 mm	
2=5.55 mm	
3=3.55 mm	
4=4.55 mm	0.76
5=5.55 mm	
7=3.55 mm	
8=4.55 mm	
9=5.55 mm	
	1.27

PART NUMBER TABLE				
ASSY PART NO.	K	L	P	TOTAL NO. OF DIFFERENTIAL PAIRS
75237-010*	9	16.65	18.35	50
75237-020*	24	44.40	46.10	125

LEAD-FREE PLATING

REV TO LEAD-FREE IEC NO.: UICP2013-1905 D: 2012/09/06 CHYKHOLFE APPROX: MILLER 2012/12/05	QUALITY SYMBOLS ▽=0 ▽=0 ▽=0	GENERAL TOLERANCES (UNLESS SPECIFIED) <table border="1"> <thead> <tr> <th></th> <th>mm</th> <th>INCH</th> </tr> </thead> <tbody> <tr> <td>4 PLACES</td> <td>±0.15</td> <td>±---</td> </tr> <tr> <td>3 PLACES</td> <td>±---</td> <td>±---</td> </tr> <tr> <td>2 PLACES</td> <td>±0.25</td> <td>±---</td> </tr> <tr> <td>1 PLACE</td> <td>±0.38</td> <td>±---</td> </tr> <tr> <td>0 PLACE</td> <td>±---</td> <td>±---</td> </tr> </tbody> </table>		mm	INCH	4 PLACES	±0.15	±---	3 PLACES	±---	±---	2 PLACES	±0.25	±---	1 PLACE	±0.38	±---	0 PLACE	±---	±---	DIMENSION STYLE MM ONLY	SCALE 5:1	DESIGN UNITS METRIC	THIRD ANGLE PROJECTION
		mm	INCH																					
	4 PLACES	±0.15	±---																					
	3 PLACES	±---	±---																					
2 PLACES	±0.25	±---																						
1 PLACE	±0.38	±---																						
0 PLACE	±---	±---																						
DRAWN BY NMARTIN DATE 2003/12/15	CHECKED BY SREED DATE 2003/12/15	APPROVED BY CBI XLER DATE 2003/12/15	MATERIAL NO. SEE CHART	DOCUMENT NO. SD-75237-010	GBX 5-PAIR LF OPEN END BACKPLANE SALES ASSEMBLY	molex																		
DRAFT WHERE APPLICABLE MUST REMAIN WITHIN DIMENSIONS	ANGULAR ±1/2°	SIZE D	THIS DRAWING CONTAINS INFORMATION THAT IS PROPRIETARY TO MOLEX INCORPORATED AND SHOULD NOT BE USED WITHOUT WRITTEN PERMISSION	SHEET NO. 1 OF 1																				