

THIS DRAWING IS UNPUBLISHED. RELEASED FOR PUBLICATION 20
 © COPYRIGHT 20 BY - ALL RIGHTS RESERVED.

SUGGESTED MATING TAB

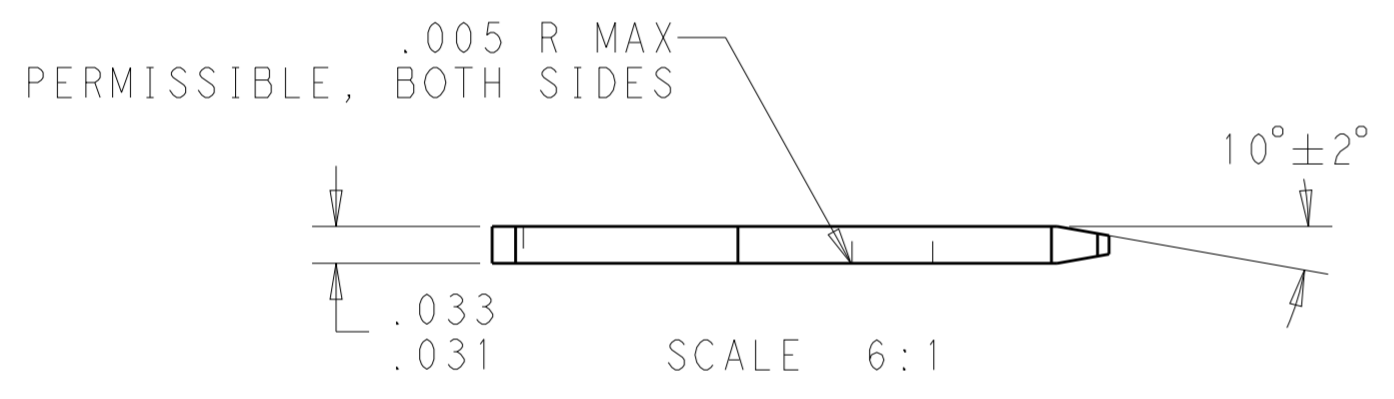

- 1 MATL: 1/2H BRASS OR NICKEL PL STEEL
- 2 NO BURRS PERMISSIBLE AT HOLE
- △ MUST BE FLAT WITHIN .003 OVER THIS LENGTH
- 4 TIN PLATING IS REQUIRED ON BRASS WHEN TERMINAL TEMP IS OVER 225° F.
- 5 HOLE MUST BE SYMMETRICAL ABOUT TAB CENTERLINE WITHIN .003
- * TO BE USED ONLY WHEN SHOULDER IS ELIMINATED.

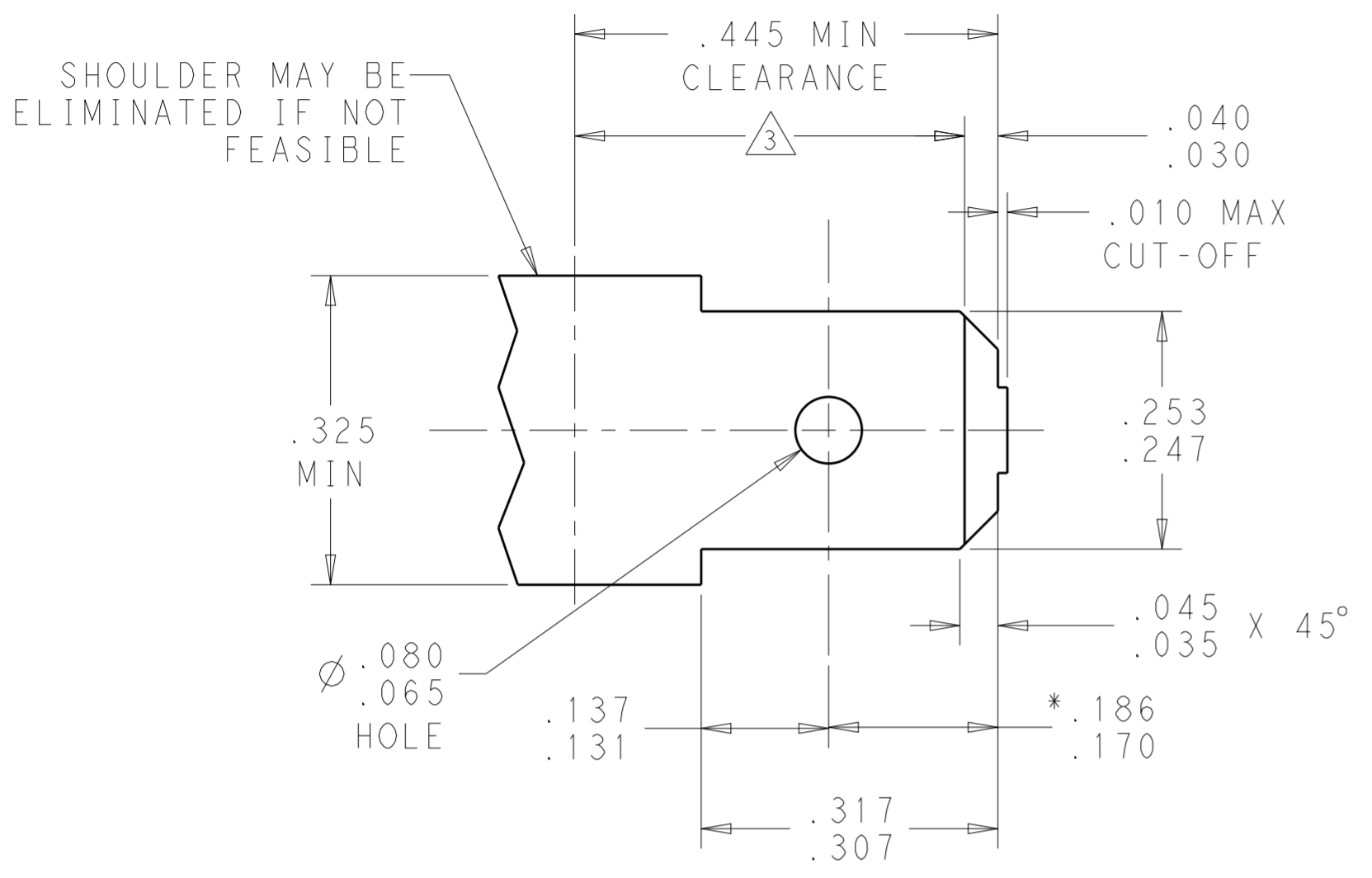
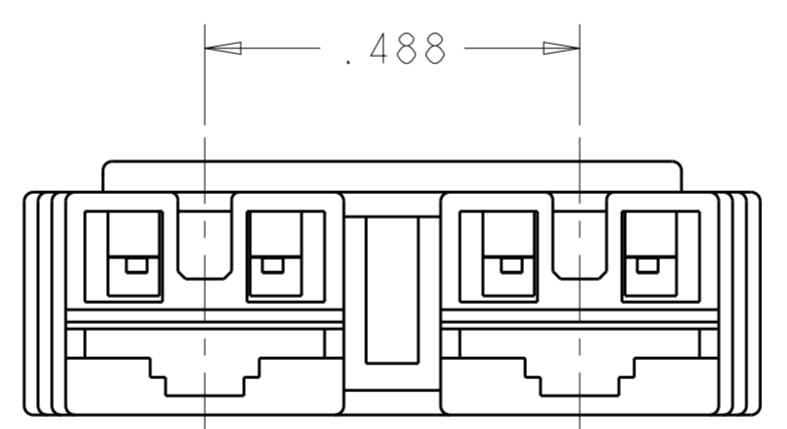
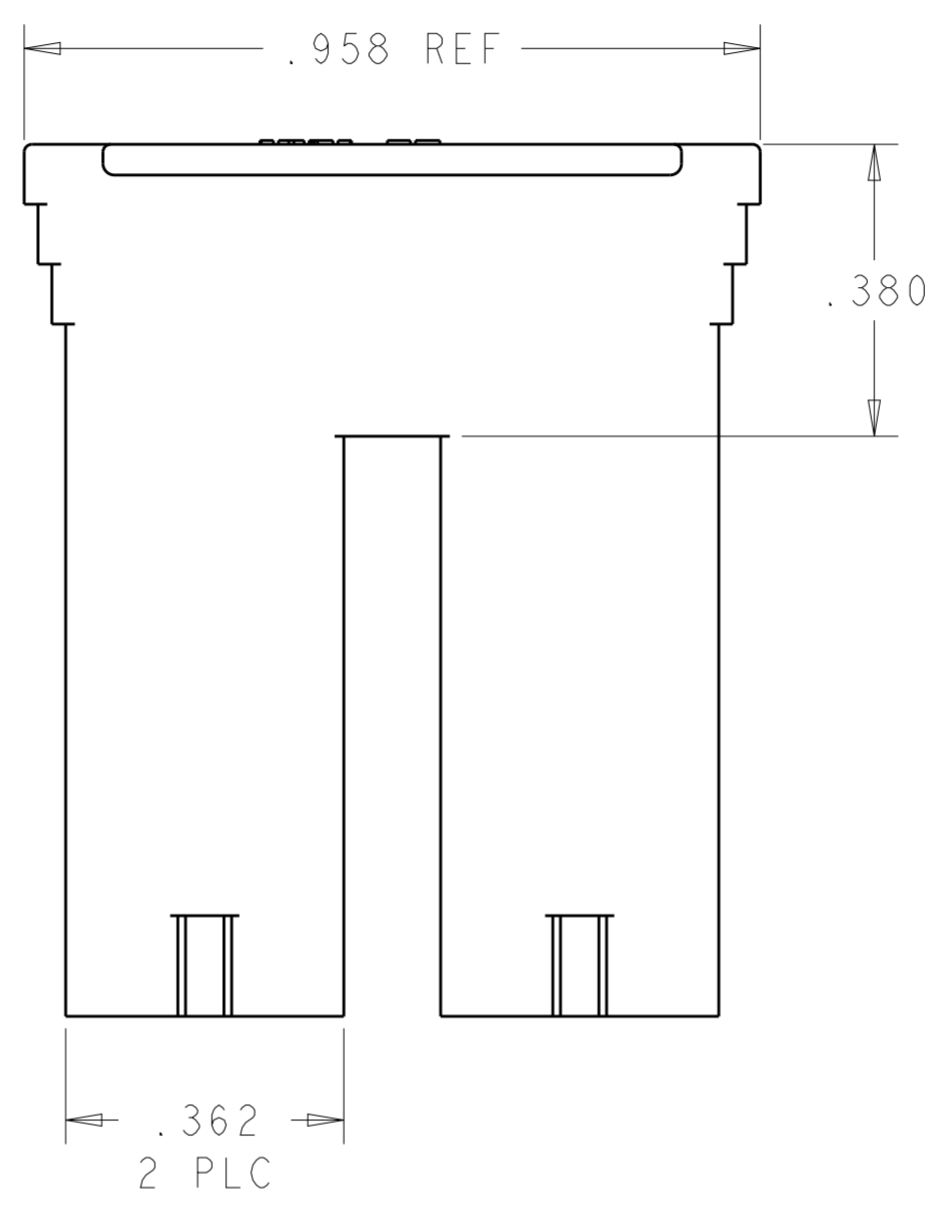
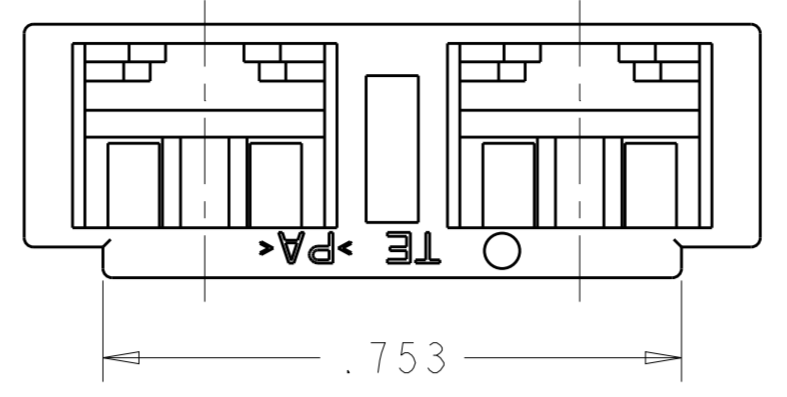
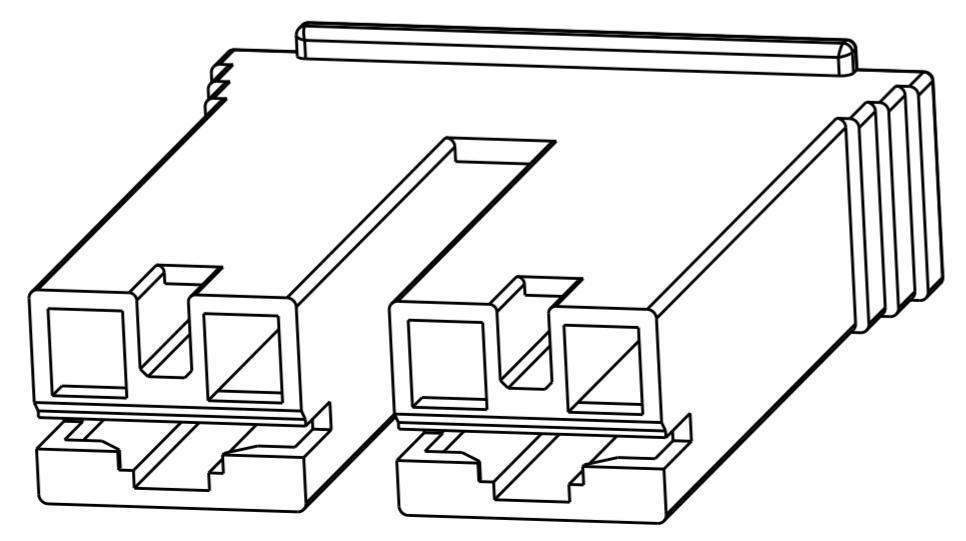

- 1 FOR USE WITH MKII POSITIVE LOCK, LOW INSERTION FORCE FASTON RECEPTACLES AND MOST BUDGET FASTON RECEPTACLES.
- △ PRELIMINARY - NOT FOR PRODUCTION

LOC		DIST		REVISIONS			
P	LTR	DESCRIPTION	DATE	DWN	APVD		
	A6	REVISED PER ECO-18-011385	23JUL2018	RS	DS		

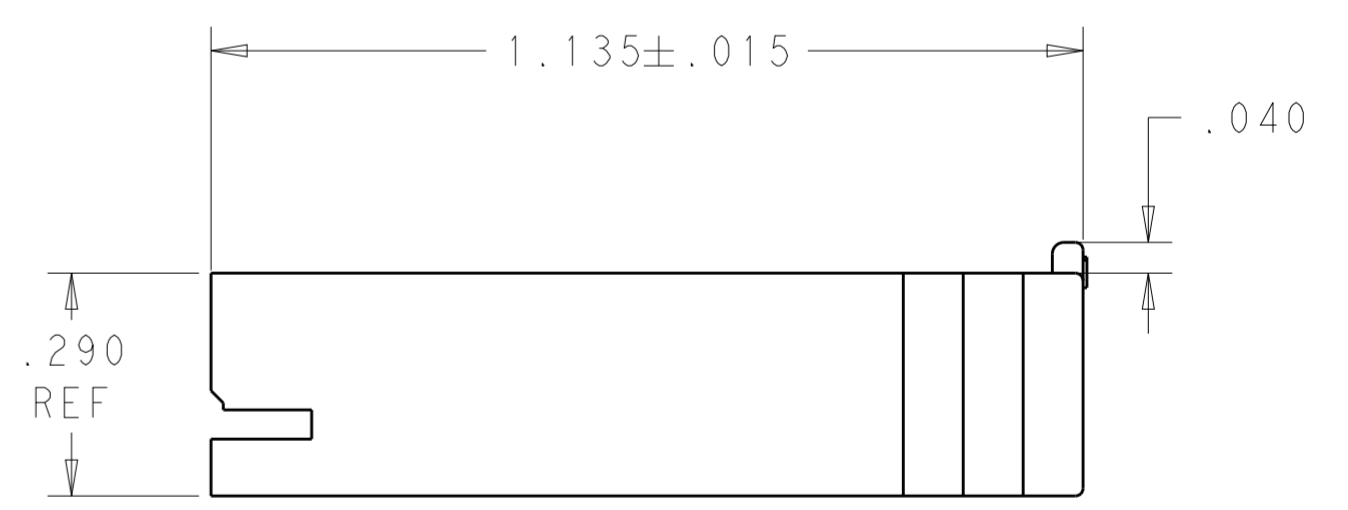

COLOR	MATERIAL	PART NO.
NATURAL	66 Nylon V0 Natural, GWT	1969332-3
NATURAL (WHITE)	66/6 NYLON V0	1969332-2
NATURAL (TRANSLUCENT)	6/6 NYLON V2	△ 1969332-1

THIS DRAWING IS A CONTROLLED DOCUMENT.

DIMENSIONS: INCHES	TOLERANCES UNLESS OTHERWISE SPECIFIED:	DWN: JR RUTH 21OCT2009	 TE Connectivity
	0 PLC ±-	CHK: GARY PORTA 21OCT2009	
	1 PLC ±.1	APVD: GARY PORTA 21OCT2009	
	2 PLC ±.02	NAME: HOUSING, RECPT, POSITIVE-LOCK AND STANDARD FASTON, .250 SERIES MKII	
MATERIAL: SEE TABLE	FINISH: SEE TABLE	PRODUCT SPEC: 108-5127	SIZE: A2
		APPLICATION SPEC: 114-2074	CAGE CODE: 00779
		WEIGHT: -	DRAWING NO: C-1969332
		Customer Drawing	RESTRICTED TO: -

SCALE: 8:1 SHEET 1 OF 1 REV A6