

ISO VIEW

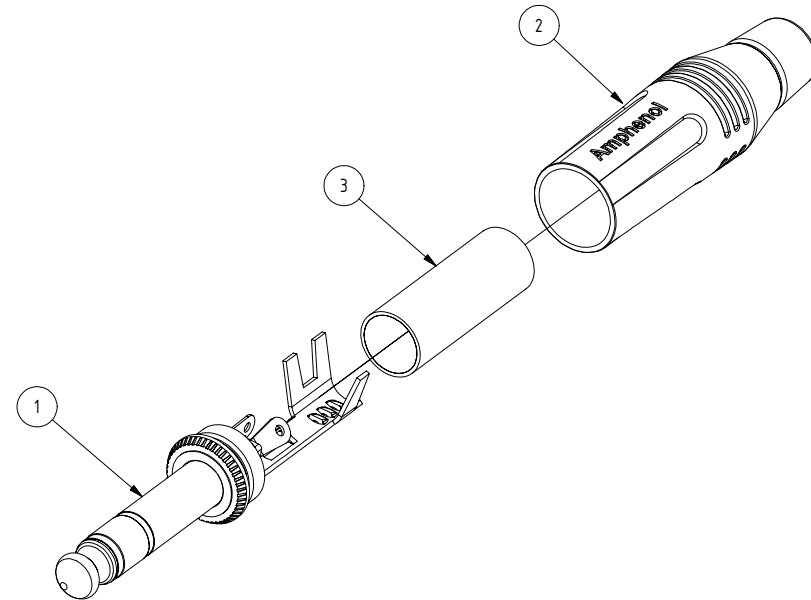

Parts List				
ITEM	PART NUMBER	DWG No	DESCRIPTION	QTY
1	50310006-*30	50310006-130-1	INSERT ASSEMBLY	1
2	53490001-*31	53490001-331-1	BACKSHELL ASSEMBLY	1
3	51270016-521	51270016-521-1	PVC INSULATION TUBE	1

Part Numbers According to Shell and Contact Finish			
CATALOGUE P/No	REFERENCE P/No.	SHELL FINISH	CONTACT FINISH
ACPS-GN	55010217-000	NICKEL	NICKEL RING, SLEEVE AND TIP
ACPS-GN-AU	55010217-001	NICKEL	GOLD RING, SLEEVE AND TIP
ACPS-GB	55010217-002	BLACK	NICKEL RING, SLEEVE AND TIP
ACPS-GB-AU	55010217-003	BLACK	GOLD RING, SLEEVE AND TIP

UNLESS OTHERWISE SPECIFIED TOLERANCE TO BE		THIS DOCUMENT IS THE PROPERTY OF AMPHENOL AUSTRALIA PTY LTD. NO PART THEREOF MAY BE REPRODUCED AND USED WITHOUT THE PRIOR WRITTEN CONSENT OF THE OWNER				1	UPDATE TO MODIFIED COMPONENT	LV	1/03/2004	8241	
LINEAR		ANGULAR		CAD FILE: 55010217000111		0	FIRST ISSUE	T.N	21/11/2002	----	
X ± 0.5	X ± 1	DSD: T.N		DATE: 21/11/2002	TITLE: 1/4" PHONE PLUG STEREO ASSY	CHANGE DETAILS		BY	DATE	CHG/No	
XX ± 0.1	XX ± 30'	MATERIAL: REFER TO COMPONENTS		DATE: 04-05-04	DO NOT SCALE		FINISH: SEE TABLE		APP'D: P.M		
XXX ± 0.05	XXX ± 15'	SCALE: 2:1 UOS		DATE: 04-05-04	DIMENSIONS IN MILLIMETRES		THIRD ANGLE PROJECTION		SCALE: 2:1 UOS		
BREAK ALL SHARP EDGES AND REMOVE ALL BURRS		PART No: SEE TABLE		SIZE: A3		DRAWING NO. 55010217-000-1		SHEET 1/1		Amphenol Australia Pty Ltd, 2 Fineways Blvd, Keysborough, Vic3173	