

# DM74LS153

## Dual 4-Line to 1-Line Data Selectors/Multiplexers

### General Description

Each of these data selectors/multiplexers contains inverters and drivers to supply fully complementary, on-chip, binary decoding data selection to the AND-OR-invert gates. Separate strobe inputs are provided for each of the two four-line sections.

### Features

- Permits multiplexing from N lines to 1 line

- Performs at parallel-to-serial conversion
- Strobe (enable) line provided for cascading (N lines to n lines)
- High fan-out, low impedance, totem pole outputs
- Typical average propagation delay times
  - From data 14 ns
  - From strobe 19 ns
  - From select 22 ns
- Typical power dissipation 31 mW

### Connection Diagram

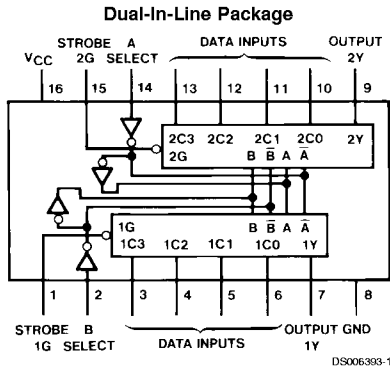

Order Number 54LS153DMQB, 54LS153FMQB,  
54LS153LMQB,  
DM54LS153J, DM54LS153W,  
DM74LS153M or DM74LS153N  
See Package Number E20A, J16A, M16A,  
N16E or W16A

### Logic Diagram

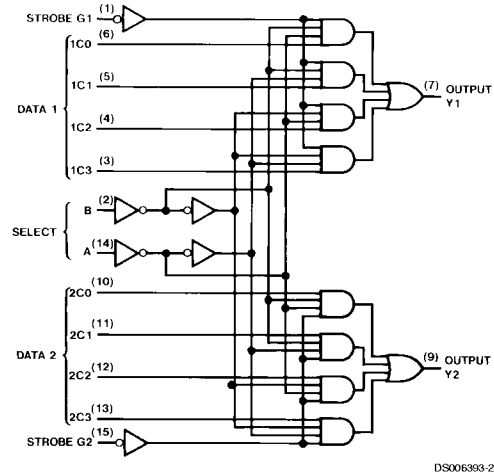

DM74LS153 Dual 4-Line to 1-Line Data Selectors/Multiplexers

## Function Table

| Select Inputs |   | Data Inputs |    |    |    | Strobe | Output |
|---------------|---|-------------|----|----|----|--------|--------|
| B             | A | C0          | C1 | C2 | C3 | G      | Y      |
| X             | X | X           | X  | X  | X  | H      | L      |
| L             | L | L           | X  | X  | X  | L      | L      |
| L             | L | H           | X  | X  | X  | L      | H      |
| L             | H | X           | L  | X  | X  | L      | L      |
| L             | H | X           | H  | X  | X  | L      | H      |
| H             | L | X           | X  | L  | X  | L      | L      |
| H             | L | X           | X  | H  | X  | L      | H      |
| H             | H | X           | X  | X  | L  | L      | L      |
| H             | H | X           | X  | X  | H  | L      | H      |

Select inputs A and B are common to both sections.  
H = High Level, L = Low Level, X = Don't Care

## Absolute Maximum Ratings (Note 1)

|                                      |    |                           |                 |
|--------------------------------------|----|---------------------------|-----------------|
| Supply Voltage                       | 7V | DM54LS and 54LS           | -55°C to +125°C |
| Input Voltage                        | 7V | DM74LS                    | 0°C to +70°C    |
| Operating Free Air Temperature Range |    | Storage Temperature Range | -65°C to +150°C |

## Recommended Operating Conditions

| Symbol          | Parameter                      | DM54LS153 |     |      | DM74LS153 |     |      | Units |
|-----------------|--------------------------------|-----------|-----|------|-----------|-----|------|-------|
|                 |                                | Min       | Nom | Max  | Min       | Nom | Max  |       |
| V <sub>CC</sub> | Supply Voltage                 | 4.5       | 5   | 5.5  | 4.75      | 5   | 5.25 | V     |
| V <sub>IH</sub> | High Level Input Voltage       | 2         |     |      | 2         |     |      | V     |
| V <sub>IL</sub> | Low Level Input Voltage        |           |     | 0.7  |           |     | 0.8  | V     |
| I <sub>OH</sub> | High Level Output Current      |           |     | -0.4 |           |     | -0.4 | mA    |
| I <sub>OL</sub> | Low Level Output Current       |           |     | 4    |           |     | 8    | mA    |
| T <sub>A</sub>  | Free Air Operating Temperature | -55       |     | 125  | 0         |     | 70   | °C    |

**Note 1:** The "Absolute Maximum Ratings" are those values beyond which the safety of the device cannot be guaranteed. The device should not be operated at these limits. The parametric values defined in the "Electrical Characteristics" table are not guaranteed at the absolute maximum ratings. The "Recommended Operating Conditions" table will define the conditions for actual device operation.

## Electrical Characteristics

over recommended operating free air temperature range (unless otherwise noted)

| Symbol          | Parameter                         | Conditions                                     | Min  | Typ<br>(Note 2) | Max   | Units |
|-----------------|-----------------------------------|------------------------------------------------|------|-----------------|-------|-------|
| V <sub>I</sub>  | Input Clamp Voltage               | V <sub>CC</sub> = Min, I <sub>I</sub> = -18 mA |      |                 | -1.5  | V     |
| V <sub>OH</sub> | High Level Output Voltage         | V <sub>CC</sub> = Min, I <sub>OH</sub> = Max   | DM54 | 2.5             | 3.4   | V     |
|                 |                                   | V <sub>IL</sub> = Max, V <sub>IH</sub> = Min   | DM74 | 2.7             | 3.4   |       |
| V <sub>OL</sub> | Low Level Output Voltage          | V <sub>CC</sub> = Min, I <sub>OL</sub> = Max   | DM54 | 0.25            | 0.4   | V     |
|                 |                                   | V <sub>IL</sub> = Max, V <sub>IH</sub> = Min   | DM74 | 0.35            | 0.5   |       |
|                 |                                   | I <sub>OL</sub> = 4 mA, V <sub>CC</sub> = Min  | DM74 | 0.25            | 0.4   |       |
| I <sub>I</sub>  | Input Current @ Max Input Voltage | V <sub>CC</sub> = Max, V <sub>I</sub> = 7V     |      |                 | 0.1   | mA    |
| I <sub>IH</sub> | High Level Input Current          | V <sub>CC</sub> = Max, V <sub>I</sub> = 2.7V   |      |                 | 20    | μA    |
| I <sub>IL</sub> | Low Level Input Current           | V <sub>CC</sub> = Max, V <sub>I</sub> = 0.4V   |      |                 | -0.36 | mA    |
| I <sub>OS</sub> | Short Circuit Output Current      | V <sub>CC</sub> = Max                          | DM54 | -20             | -100  | mA    |
|                 |                                   | (Note 3)                                       | DM74 | -20             | -100  |       |
| I <sub>CC</sub> | Supply Current                    | V <sub>CC</sub> = Max (Note 4)                 |      | 6.2             | 10    | mA    |

**Note 2:** All typicals are at V<sub>CC</sub> = 5V, T<sub>A</sub> = 25°C.

**Note 3:** Not more than one output should be shorted at a time, and the duration should not exceed one second.

**Note 4:** I<sub>CC</sub> is measured with all outputs open and all other inputs grounded.

## Switching Characteristics

at  $V_{CC} = 5V$  and  $T_A = 25^\circ C$

| Symbol    | Parameter                                          | From (Input)<br>to (Output) | $R_L = 2\text{ k}\Omega$ |     |                      |     | Units |
|-----------|----------------------------------------------------|-----------------------------|--------------------------|-----|----------------------|-----|-------|
|           |                                                    |                             | $C_L = 15\text{ pF}$     |     | $C_L = 50\text{ pF}$ |     |       |
|           |                                                    |                             | Min                      | Max | Min                  | Max |       |
| $t_{PLH}$ | Propagation Delay Time<br>Low to High Level Output | Data to Y                   |                          | 15  |                      | 20  | ns    |
| $t_{PHL}$ | Propagation Delay Time<br>High to Low Level Output | Data to Y                   |                          | 26  |                      | 35  | ns    |
| $t_{PLH}$ | Propagation Delay Time<br>Low to High Level Output | Select to Y                 |                          | 29  |                      | 35  | ns    |
| $t_{PHL}$ | Propagation Delay Time<br>High to Low Level Output | Select to Y                 |                          | 38  |                      | 45  | ns    |
| $t_{PLH}$ | Propagation Delay Time<br>Low to High Level Output | Strobe to Y                 |                          | 24  |                      | 30  | ns    |
| $t_{PHL}$ | Propagation Delay Time<br>High to Low Level Output | Strobe to Y                 |                          | 32  |                      | 40  | ns    |

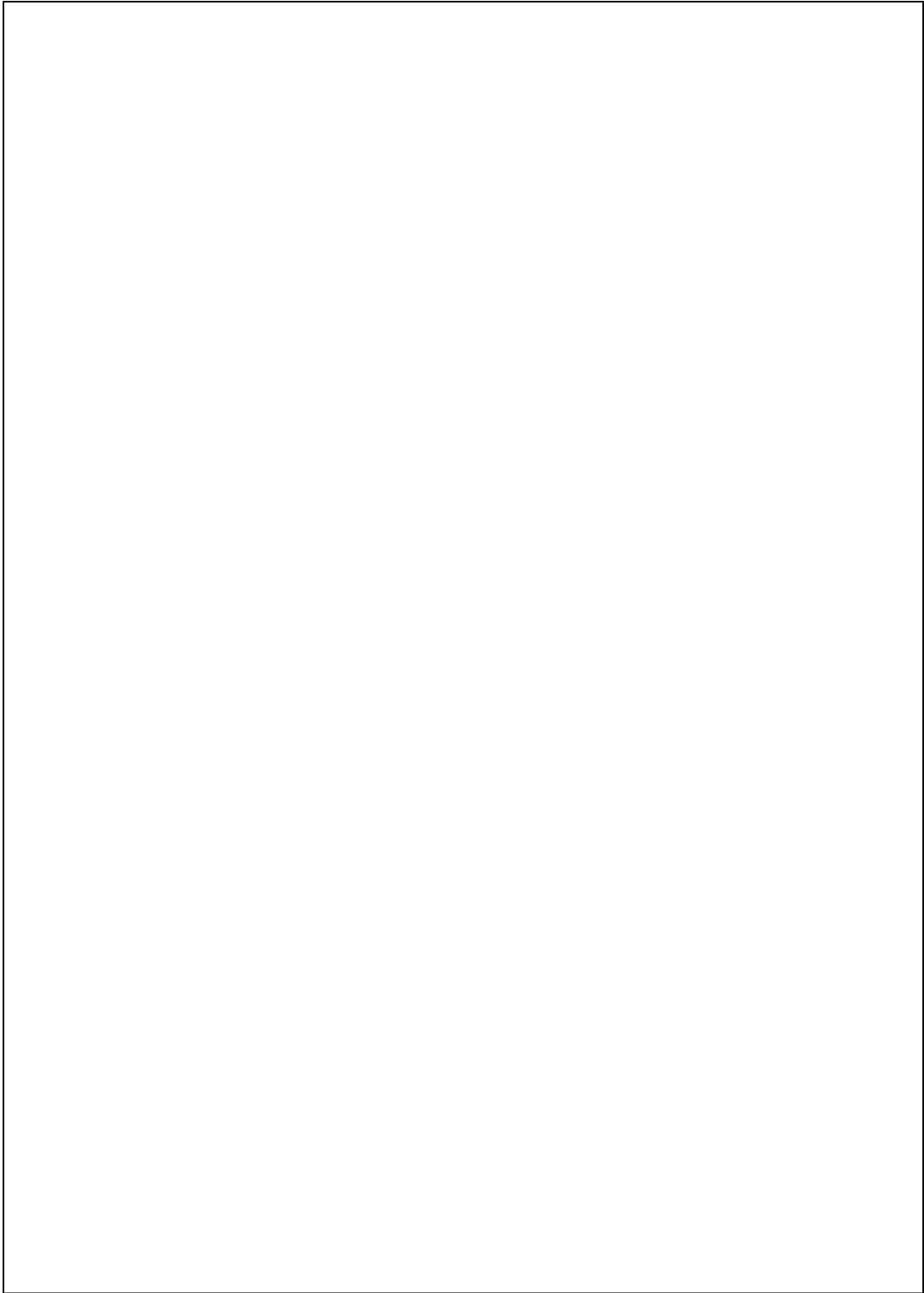

**Physical Dimensions** inches (millimeters) unless otherwise noted

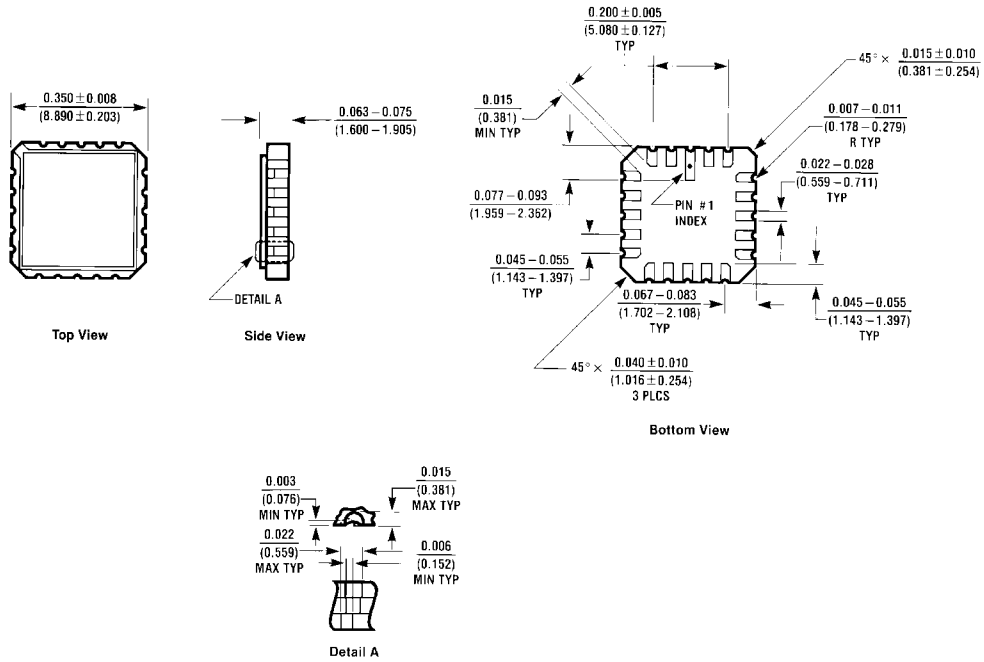

E/DA (REV D)

**Ceramic Leadless Chip Carrier Package (E)**  
**Order Number 54LS153LMQB**  
**Package Number E20A**

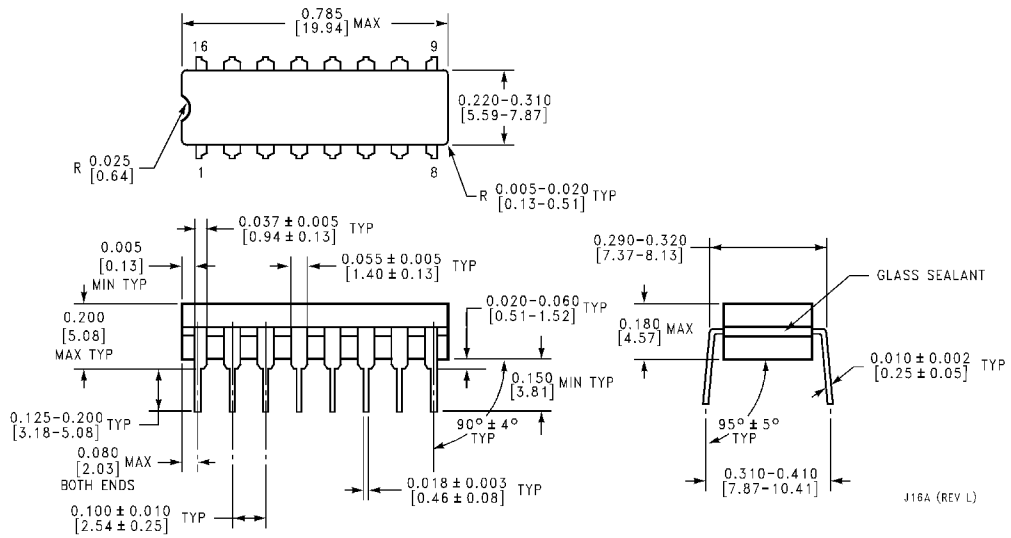

J16A (REV L)

**16-Lead Ceramic Dual-In-Line Package (J)**  
**Order Number 54LS153DMQB or DM54LS153J**  
**Package Number J16A**



**Physical Dimensions** inches (millimeters) unless otherwise noted (Continued)

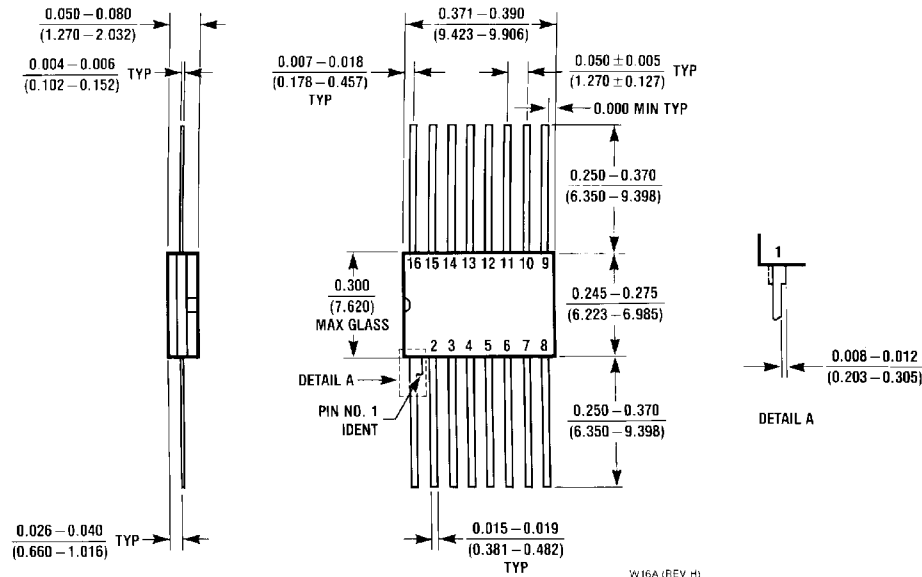

**16-Lead Ceramic Flat Package (W)**  
**Order Number 54LS153FMQB or DM54LS153W**  
**Package Number W16A**

**LIFE SUPPORT POLICY**

FAIRCHILD'S PRODUCTS ARE NOT AUTHORIZED FOR USE AS CRITICAL COMPONENTS IN LIFE SUPPORT DEVICES OR SYSTEMS WITHOUT THE EXPRESS WRITTEN APPROVAL OF THE PRESIDENT OF FAIRCHILD SEMICONDUCTOR CORPORATION. As used herein:

1. Life support devices or systems are devices or systems which, (a) are intended for surgical implant into the body, or (b) support or sustain life, and (c) whose failure to perform when properly used in accordance with instructions for use provided in the labeling, can be reasonably expected to result in a significant injury to the user.
2. A critical component in any component of a life support device or system whose failure to perform can be reasonably expected to cause the failure of the life support device or system, or to affect its safety or effectiveness.

Fairchild Semiconductor Corporation  
 Americas  
 Customer Response Center  
 Tel: 1-888-522-5372

Fairchild Semiconductor Europe  
 Fax: +49 (0) 1 80-530 85 86  
 Email: europe.support@nsc.com  
 Deutsch Tel: +49 (0) 8 141-35-0  
 English Tel: +44 (0) 1 793-85-68-56  
 Italy Tel: +39 (0) 2 57 5631

Fairchild Semiconductor Hong Kong Ltd.  
 13th Floor, Straight Block,  
 Ocean Centre, 5 Canton Rd.  
 Tsimshatsui, Kowloon  
 Hong Kong  
 Tel: +852 2737-7200  
 Fax: +852 2314-0061

National Semiconductor Japan Ltd.  
 Tel: 81-3-5620-6175  
 Fax: 81-3-5620-6179

www.fairchildsemi.com