

4

3

2

1

THIS DRAWING IS UNPUBLISHED. RELEASED FOR PUBLICATION AUG, 2006.

© COPYRIGHT BY TYCO ELECTRONICS CORPORATION. ALL RIGHTS RESERVED.

LOC	DIST	REVISIONS			
P	LTR	DESCRIPTION	DATE	DWN	APVD
DW	-	C	REVISED (ECR-13-003844)	22APR13	JL WK

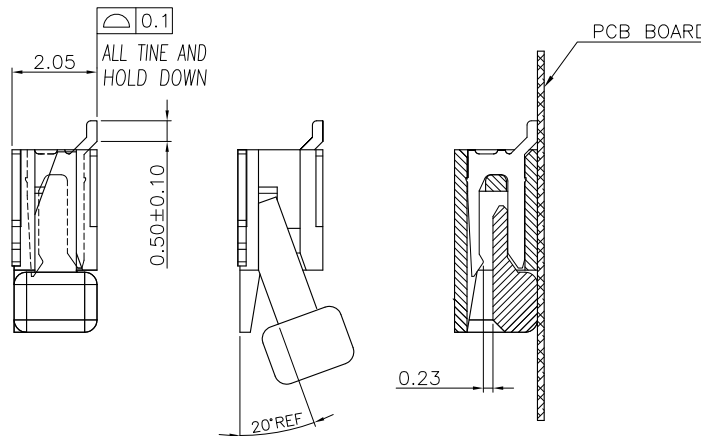
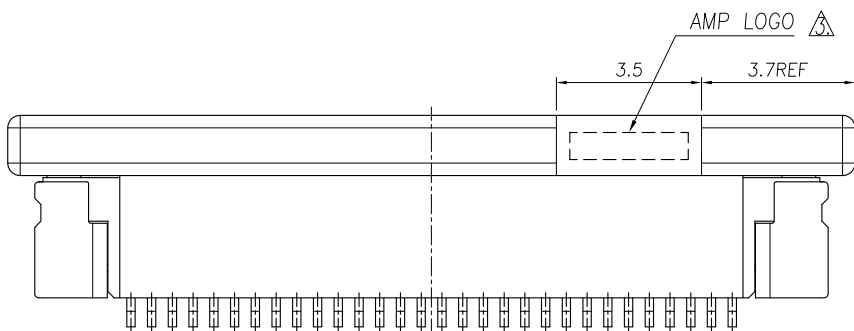
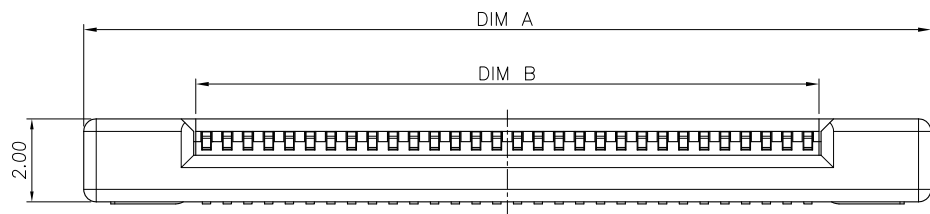
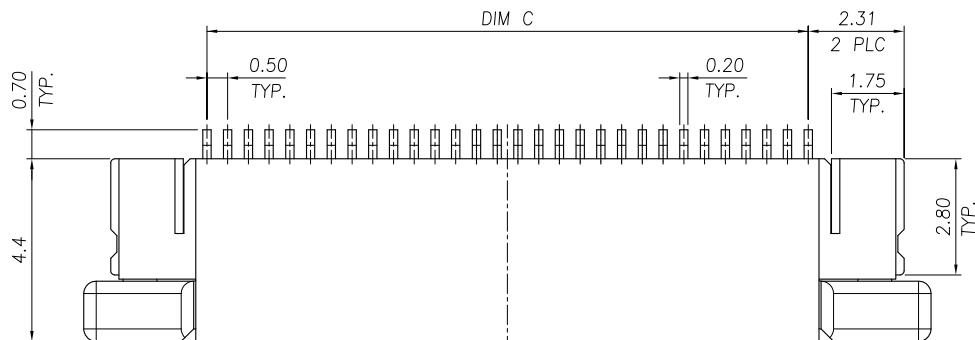

24.50	25.60	30.43	50	5-1734839-0
24.00	25.10	29.93	49	4-1734839-9
23.50	24.60	29.43	48	4-1734839-8
23.00	24.10	28.93	47	4-1734839-7
22.50	23.60	28.43	46	4-1734839-6
22.00	23.10	27.63	45	4-1734839-5
21.50	22.60	27.43	44	4-1734839-4
21.00	22.10	26.93	43	4-1734839-3
20.50	21.60	26.43	42	4-1734839-2
20.00	21.10	25.93	41	4-1734839-1
19.50	20.60	25.43	40	4-1734839-0
19.00	20.10	24.93	39	3-1734839-9
18.50	19.60	24.43	38	3-1734839-8
18.00	19.10	23.93	37	3-1734839-7
17.50	18.60	23.43	36	3-1734839-6
17.00	18.10	22.93	35	3-1734839-5
16.50	17.60	22.43	34	3-1734839-4
16.00	17.10	21.93	33	3-1734839-3
15.50	16.60	21.43	32	3-1734839-2
15.00	16.10	20.93	31	3-1734839-1
14.50	15.60	20.43	30	3-1734839-0
14.00	15.10	19.93	29	2-1734839-9
13.50	14.60	19.43	28	2-1734839-8
13.00	14.10	18.93	27	2-1734839-7
12.50	13.60	18.43	26	2-1734839-6
12.00	13.10	17.93	25	2-1734839-5
11.50	12.60	17.43	24	2-1734839-4
11.00	12.10	16.93	23	2-1734839-3
10.50	11.60	16.43	22	2-1734839-2
10.00	11.10	15.93	21	2-1734839-1
9.50	10.60	15.43	20	2-1734839-0
9.00	10.10	14.93	19	1-1734839-9
8.50	9.60	14.43	18	1-1734839-8
8.00	9.10	13.93	17	1-1734839-7
7.50	8.60	13.43	16	1-1734839-6
7.00	8.10	12.93	15	1-1734839-5
6.50	7.60	12.43	14	1-1734839-4
6.00	7.10	11.93	13	1-1734839-3
5.50	6.60	11.43	12	1-1734839-2
5.00	6.10	10.93	11	1-1734839-1
4.50	5.60	10.43	10	1-1734839-0
4.00	5.10	9.93	09	0-1734839-9
3.50	4.60	9.43	08	0-1734839-8
3.00	4.10	8.93	07	0-1734839-7
2.50	3.60	8.43	06	0-1734839-6
2.00	3.10	7.93	05	0-1734839-5
C	B	A	POS.	PART NUMBER
DIMENSIONS				

NOTE:

- MATERIAL:  
HOUSING: HIGH TEMP. THERMOPLASTIC, UL 94V-0, COLOR: NATURE.  
ACTUATOR: THERMOPLASTIC, UL 94 V-0, COLOR: IVORY.  
HOLD DOWN: PHOSPHOR BRONZE.  
CONTACT: PHOSPHOR BRONZE.
- FINISH:  
CONTACT: GOLD FLASH OVER ALL  
50" MIN. NICKEL UNDERPLATED.  
HOLD DOWN: 100u" MIN. TIN PLATING ON SOLDER AREA,  
50u" MIN. NICKEL UNDERPLATED ALL OVER.  
⚠ WITHOUT AMP LOGO FOR 12 POSITION UNDER.

THIS DRAWING IS A CONTROLLED DOCUMENT.		DWN J. LAI 15APR2009	TE Connectivity		
DIMENSIONS: MM		CHK S. CHIEN 15APR2009			
TOLERANCES UNLESS OTHERWISE SPECIFIED:		APVD W. KODAMA 15APR2009	NAME		
		PRODUCT SPEC 108-57523	FPC CONNECTOR, 0.5mm PITCH, TOP CONTACT, SMT TYPE.		
MATERIAL SEE NOTE		QUALIFICATION TEST REPORT 501-57598	SIZE A3	CAGE CODE 00779	DRAWING NO C=1734839
FINISH SEE NOTE		WEIGHT - GRAMS	RESTRICTED TO -		
CUSTOMER DRAWING			SCALE -	SHEET 1 OF 3	REV C

THIS DRAWING IS UNPUBLISHED.

RELEASED FOR PUBLICATION

AUG ,2006.

© COPYRIGHT BY TYCO ELECTRONICS CORPORATION.

ALL RIGHTS RESERVED.

LOC DW

DIST

REVISIONS

P

LTR

DESCRIPTION

DATE

DWN

APVD

SEE SHEET 1.

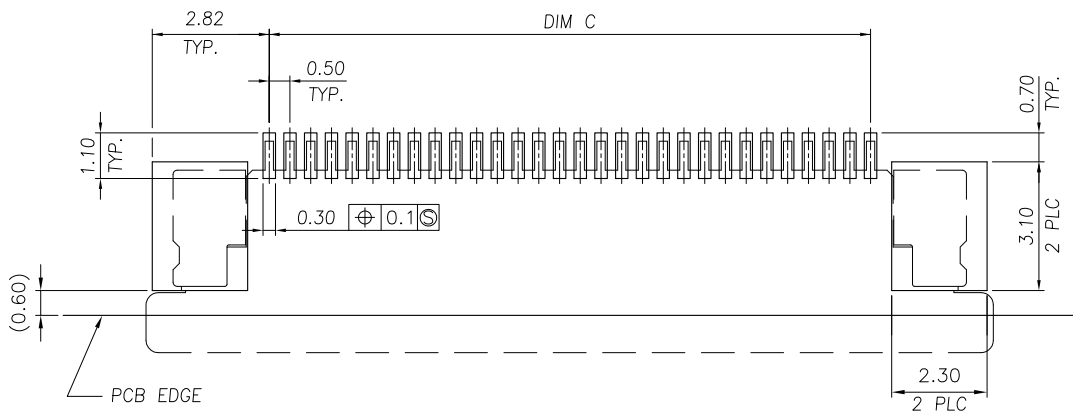

RECOMMENDED PCB DIMENSIONS DIAGRAM

TOLERANCE: ±0.05

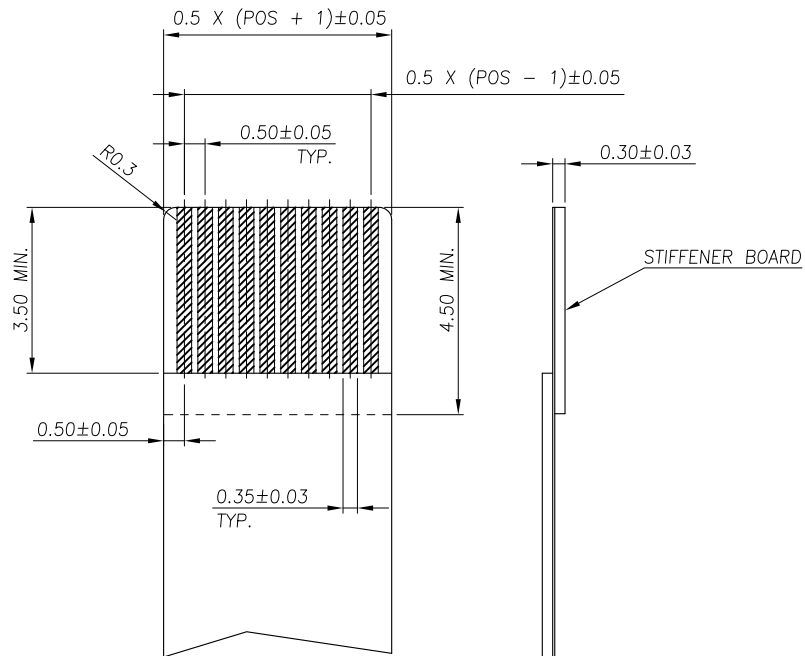

RECOMMENDED FPC DIMENSIONS DIAGRAM

THIS DRAWING IS A CONTROLLED DOCUMENT.		DWN		<b>STE</b> TE Connectivity	
DIMENSIONS: MM		CHK			
TOLERANCES UNLESS OTHERWISE SPECIFIED:		APVD		NAME	
0 PLC ± -		PRODUCT SPEC		FPC CONNECTOR, 0.5mm PITCH, TOP CONTACT, SMT TYPE.	
1 PLC ± -		APPLICATION SPEC		SIZE CAGE CODE DRAWING NO RESTRICTED TO	
2 PLC ± -		WEIGHT		A3 00779 C=1734839	
3 PLC ± -		CUSTOMER DRAWING		SCALE SHEET 2 OF 3 REV C	
4 PLC ± -					
ANGLES ± -					
MATERIAL					
FINISH					

THIS DRAWING IS UNPUBLISHED. RELEASED FOR PUBLICATION AUG, 2006.

© COPYRIGHT BY TYCO ELECTRONICS CORPORATION. ALL RIGHTS RESERVED.

LOC		DIST		REVISIONS			
P	LTR	DESCRIPTION	DATE	DWN	APVD		
SEE SHEET 1.							

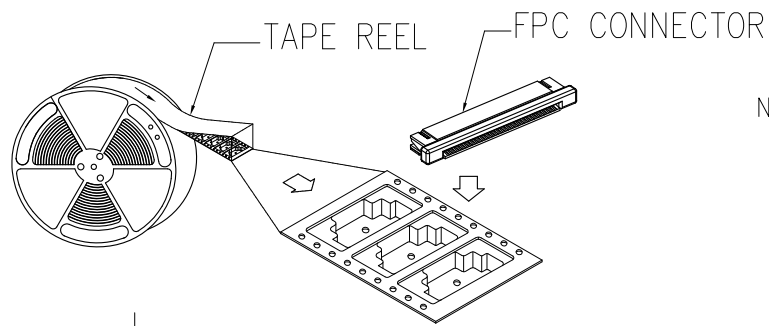
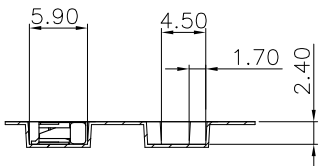
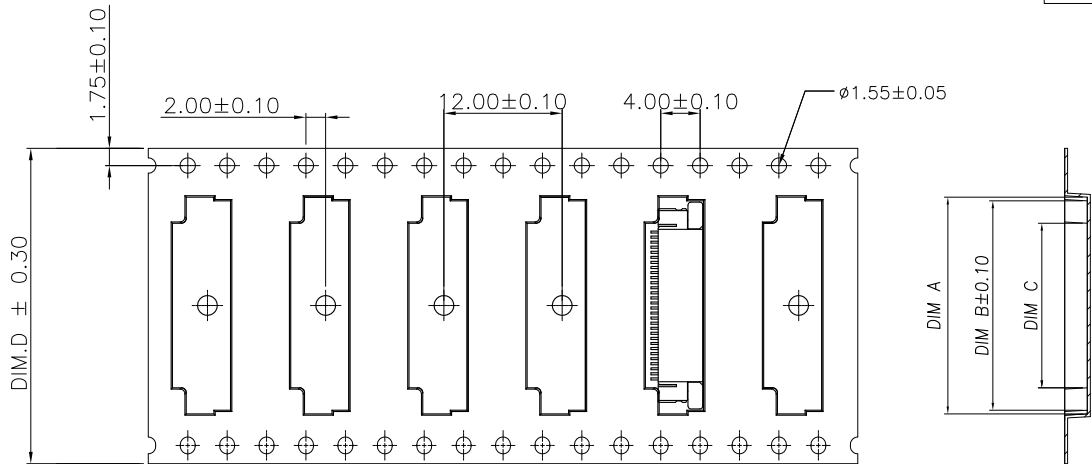

NOTE :

1. TAPE REEL:  
DIAMETER: 13", THICKNESS : 0.35±0.05mm.
2. CARTON:  
SIZE: 350mm(L)X 350mm(W)X 340mm(H).
3. WEIGHT:  
NET WEIGHT: 7.5kg  
GROSS WEIGHT: 13.4kg

APQ (PCS/CARTON)	PPQ (PCS/REEL)	D	C	B	A	POS.	PART NUMBER
44.00	26.70	30.55	31.50	50	5	5-1734839-0	
44.00	26.20	30.05	31.00	49	4	4-1734839-9	
44.00	25.70	29.55	30.50	48	4	4-1734839-8	
44.00	25.20	29.05	30.00	47	4	4-1734839-7	
44.00	24.70	28.55	29.50	46	4	4-1734839-6	
44.00	24.20	28.05	29.00	45	4	4-1734839-5	
44.00	23.70	27.55	28.50	44	4	4-1734839-4	
44.00	23.20	27.05	28.00	43	4	4-1734839-3	
44.00	22.70	26.55	27.50	42	4	4-1734839-2	
44.00	22.20	26.05	27.00	41	4	4-1734839-1	
44.00	21.70	25.55	26.50	40	4	4-1734839-0	
44.00	21.20	25.05	26.00	39	3	3-1734839-9	
44.00	20.70	24.55	25.50	38	3	3-1734839-8	
44.00	20.20	24.05	25.00	37	3	3-1734839-7	
44.00	19.70	23.55	24.50	36	3	3-1734839-6	
44.00	19.20	23.05	24.00	35	3	3-1734839-5	
44.00	18.70	22.55	23.50	34	3	3-1734839-4	
44.00	18.20	22.05	23.00	33	3	3-1734839-3	
44.00	17.70	21.55	22.50	32	3	3-1734839-2	
44.00	17.20	21.05	22.00	31	3	3-1734839-1	
32.00	16.70	20.55	21.50	30	3	3-1734839-0	
32.00	16.20	20.05	21.00	29	2	2-1734839-9	
32.00	15.70	19.55	20.50	28	2	2-1734839-8	
32.00	15.20	19.05	20.00	27	2	2-1734839-7	
32.00	14.70	18.55	19.50	26	2	2-1734839-6	
32.00	14.20	18.05	19.00	25	2	2-1734839-5	
32.00	13.70	17.55	18.50	24	2	2-1734839-4	
32.00	13.20	17.05	18.00	23	2	2-1734839-3	
32.00	12.70	16.55	17.50	22	2	2-1734839-2	
32.00	12.20	16.05	17.00	21	2	2-1734839-1	
24.00	11.70	15.55	16.50	20	2	2-1734839-0	
24.00	11.20	15.05	16.00	19	1	1-1734839-9	
24.00	10.70	14.55	15.50	18	1	1-1734839-8	
24.00	10.20	14.05	15.00	17	1	1-1734839-7	
24.00	9.70	13.55	14.50	16	1	1-1734839-6	
24.00	9.20	13.05	14.00	15	1	1-1734839-5	
24.00	8.70	12.55	13.50	14	1	1-1734839-4	
24.00	8.20	12.05	13.00	13	1	1-1734839-3	
24.00	7.70	11.55	12.50	12	1	1-1734839-2	
24.00	7.20	11.05	12.00	11	1	1-1734839-1	
24.00	6.70	10.55	11.50	10	1	1-1734839-0	
24.00	6.20	10.05	11.00	09	0	0-1734839-9	
24.00	5.70	9.55	10.50	08	0	0-1734839-8	
24.00	5.20	9.05	10.00	07	0	0-1734839-7	
24.00	4.70	8.55	9.50	06	0	0-1734839-6	
24.00	4.20	8.05	9.00	05	0	0-1734839-5	

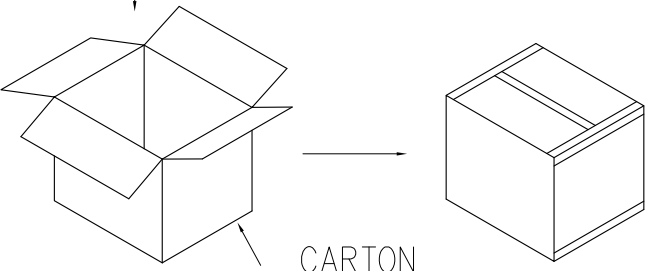

THIS DRAWING IS A CONTROLLED DOCUMENT.

DIMENSIONS: MM	TOLERANCES UNLESS OTHERWISE SPECIFIED:	DWN	CHK	APVD	NAME
0 PLC ± -	1 PLC ± -	PRODUCT SPEC	APVD	NAME	FPC CONNECTOR, 0.5mm PITCH, TOP CONTACT, SMT TYPE.
2 PLC ± -	3 PLC ± -	APPLICATION SPEC	APVD	NAME	
4 PLC ± -	ANGLES ± -	WEIGHT	APVD	NAME	SIZE CAGE CODE DRAWING NO RESTRICTED TO
MATERIAL	FINISH	CUSTOMER DRAWING	SCALE	SHEET 3 OF 3	REV C

STE TE Connectivity

A3 00779 C=1734839