

Not Recommended for New Designs

This product was manufactured for Maxim by an outside wafer foundry using a process that is no longer available. It is not recommended for new designs. The data sheet remains available for existing users.

A Maxim replacement or an industry second-source may be available. Please see the QuickView data sheet for this part or contact technical support for assistance.

For further information, [contact Maxim's Applications Tech Support](#).



Precision Operational Amplifier

MXL1001

General Description

The MXL1001 offers significant specification improvement over earlier precision operational amplifiers and is pin-compatible with the industry-standard LT1001. Particular attention has been paid to the optimization of key parameters such as input offset voltage, common-mode rejection, and power-supply rejection. In addition, the high-performance MXL1001C commercial temperature device provides considerable cost savings when compared to equivalent grades of competing precision amplifiers.

The input offset voltage of all units is less than 60 μ V, allowing the premium military device, the MXL1001AM, to be specified at 15 μ V max. Power dissipation is close to half that of the industry-standard OP-07 precision op amp, without sacrificing noise or speed performance. A useful by-product of lower dissipation is decreased warm-up drift.

Applications

Thermocouple Amplifiers
 Low-Level Signal Processing
 Strain Gauge Amplifiers
 High-Accuracy Data Acquisition

Pin Configuration

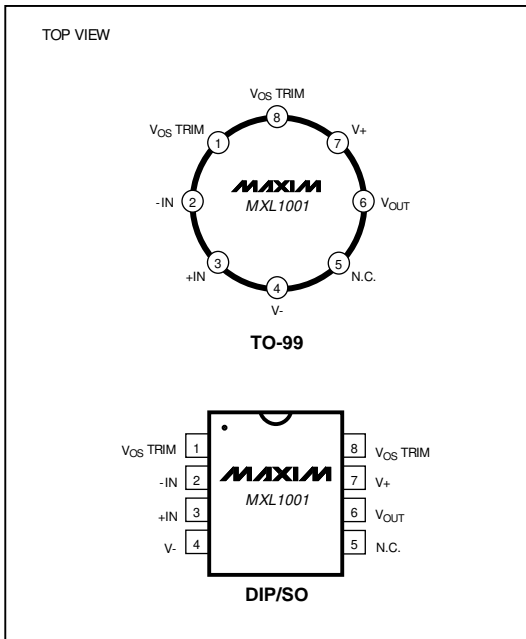

Features

- ♦ **Guaranteed Low Offset Voltage**
 MXL1001AM: 15 μ V max
 MXL1001C: 60 μ V max
- ♦ **Guaranteed Low Drift**
 MXL1001AM: 0.6 μ V/ $^{\circ}$ C max
 MXL1001C: 1.0 μ V/ $^{\circ}$ C max
- ♦ **Guaranteed Low Bias Current**
 MXL1001AM: 2nA max
 MXL1001C: 4nA max
- ♦ **Guaranteed CMRR**
 MXL1001AM: 114dB min
 MXL1001C: 110dB min
- ♦ **Guaranteed PSRR**
 MXL1001AM: 110dB min
 MXL1001C: 106dB min
- ♦ **Low Power Dissipation**
 MXL1001AM: 75mW max
 MXL1001C: 80mW max
- ♦ **Low Noise: 0.3 μ V_{p-p}**

Ordering Information

PART	TEMP. RANGE	PIN-PACKAGE
MXL1001ACN8	0 $^{\circ}$ C to +70 $^{\circ}$ C	8 Plastic DIP
MXL1001CN8	0 $^{\circ}$ C to +70 $^{\circ}$ C	8 Plastic DIP
MXL1001ACS8	0 $^{\circ}$ C to +70 $^{\circ}$ C	8 SO
MXL1001CS8	0 $^{\circ}$ C to +70 $^{\circ}$ C	8 SO
MXL1001ACJ8	0 $^{\circ}$ C to +70 $^{\circ}$ C	8 CERDIP
MXL1001CJ8	0 $^{\circ}$ C to +70 $^{\circ}$ C	8 CERDIP
MXL1001ACH	0 $^{\circ}$ C to +70 $^{\circ}$ C	8 TO-99
MXL1001CH	0 $^{\circ}$ C to +70 $^{\circ}$ C	8 TO-99
MXL1001AMJ8	-55 $^{\circ}$ C to +125 $^{\circ}$ C	8 CERDIP
MXL1001MJ8	-55 $^{\circ}$ C to +125 $^{\circ}$ C	8 CERDIP
MXL1001AMH	-55 $^{\circ}$ C to +125 $^{\circ}$ C	8 TO-99
MXL1001MH	-55 $^{\circ}$ C to +125 $^{\circ}$ C	8 TO-99

Typical Operating Circuit

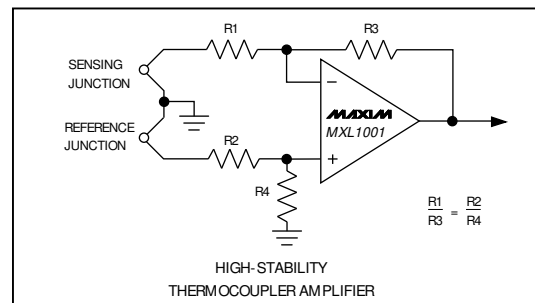

MAXIM

Maxim Integrated Products 1

Call toll free 1-800-998-8800 for free samples or literature.

Precision Operational Amplifier

ABSOLUTE MAXIMUM RATINGS

Total Supply Voltage (V+ to V-)	±22V	Duration of Output Short Circuit	Indefinite
Continuous Power Dissipation	500mW	Operating Temperature Ranges:	
TO-99(H)—derate at 7.1mW/°C above +80°C		MXL1001C_/AC_	0°C to +70°C
CERDIP(J)—derate at 6.7mW/°C above +75°C		MXL1001M_/AM_	-55°C to +125°C
Plastic DIP(P)—derate at 5.6mW/°C above +36°C		Junction Temperature (T _J)	-65°C to +160°C
Small Outline(S)—derate at 5mW/°C above +55°C		Storage Temperature Range	-65°C to +150°C
Differential Input Voltage	±30V	Lead Temperature (soldering, 10sec)	+300°C
Input Voltage (Note 1)	±22V		

Note 1: For supply voltages less than ±22V, the absolute maximum input voltage is equal to the supply voltage.

Stresses beyond those listed under "Absolute Maximum Ratings" may cause permanent damage to the device. These are stress ratings only, and functional operation of the device at these or any other conditions beyond those indicated in the operational sections of the specifications is not implied. Exposure to absolute maximum rating conditions for extended periods may affect device reliability.

ELECTRICAL CHARACTERISTICS

(V_S = ±15V, T_A = +25°C, unless otherwise noted.)

PARAMETER	SYMBOL	CONDITIONS	MXL1001AM MXL1001AC			MXL1001M MXL1001C			UNITS
			MIN	TYP	MAX	MIN	TYP	MAX	
Input Offset Voltage	V _{OS}	(Note 2)	MXL1001AM	7	15	18	60	μV	
			MXL1001AC	10	25	18	60		
Long-Term Input Offset Voltage Stability	V _{OS} /Time	(Note 3)	0.2	1.0	0.3	1.5	μV/ Month		
Input Offset Current	I _{OS}		0.3	2.0	0.4	3.8	nA		
Input Bias Current	I _B		±0.5	±2.0	±0.7	±4.0	nA		
Input Noise Voltage	e _{N p-p}	0.1Hz to 10Hz (Note 4)	0.3	0.6	0.3	0.6	μV _{p-p}		
Input Noise Voltage Density	e _N	f _O = 10Hz (Note 4)	10.3	18.0	10.5	18.0	nV/√Hz		
		f _O = 100Hz (Note 4)	10.0	13.0	10.0	13.0			
		f _O = 1000Hz (Note 4)	9.6	11.0	9.8	11.0			
Input Resistance (Differential Mode)	R _{IN}	(Note 5)	30	100	15	80	MΩ		
Input Voltage Range	IVR		±13	±14	±13	±14	V		
Common-Mode Rejection Ratio	CMRR	V _{CM} = ±13V	114	126	110	126	dB		
Power-Supply Rejection Ratio	PSRR	V _S = ±3V to ±18V	110	123	106	123	dB		
Large-Signal Voltage Gain	A _{VO}	R _L ≥ 2kΩ, V _O = ±12V	450	800	400	800	V/mV		
		R _L ≥ 1kΩ, V _O = ±10V	300	500	250	500			
Output Voltage Swing	V _O	R _L ≥ 2kΩ	±13.0	±14.0	±13.0	±14.0	V		
		R _L ≥ 1kΩ	±12.0	±13.5	±12.0	±13.5			
Slew Rate	SR	R _L ≥ 2kΩ (Note 4)	0.1	0.25	0.1	0.25	V/μs		
Closed-Loop Bandwidth	BW	A _{VCL} = +1V (Note 4)	0.4	0.8	0.4	0.8	MHz		
Power Consumption	P _D	V _S = ±15V, no load	46	75	48	80	mW		
		V _S = ±3V, no load	4	6	4	8			

Note 2: MXL1001A grade V_{OS} is measured one minute after application of power. For all other grades V_{OS} is measured approximately 0.5 seconds after application of power.

Note 3: Long-Term Input Offset Voltage Stability refers to the average trend line of V_{OS} vs. Time over extended periods after the first 30 days of operation. Excluding the initial hour of operation, changes in V_{OS} during the first 30 operating days are typically 2.5μV. Parameter is sample tested.

Note 4: Sample tested.

Note 5: Guaranteed by design.

Precision Operational Amplifier

MXL1001

ELECTRICAL CHARACTERISTICS

($V_S = \pm 15V$, $-55^\circ C \leq T_A \leq +125^\circ C$, unless otherwise noted.)

PARAMETER	SYMBOL	CONDITIONS	MXL1001AM			MXL1001M			UNITS
			MIN	TYP	MAX	MIN	TYP	MAX	
Input Offset Voltage	V_{OS}	(Note 6)	30	60		45	160		μV
Average Temperature Coefficient of Input Offset Voltage	TCV_{OS}		0.2	0.6		0.3	1.0		$\mu V/^\circ C$
Input Offset Current	I_{OS}		0.8	4.0		1.2	7.6		nA
Input Bias Current	I_B		± 1.0	± 4.0		± 1.5	± 8.0		nA
Input Voltage Range	IVR		± 13	± 14		± 13	± 14		V
Common-Mode Rejection Ratio	CMRR	$V_{CM} = \pm 13V$	110	122		106	120		dB
Power-Supply Rejection Ratio	PSRR	$V_S = \pm 3V$ to $\pm 18V$	104	117		100	117		dB
Large-Signal Voltage Gain	A_{VO}	$R_L \geq 2k\Omega$, $V_O = \pm 10V$	300	700		200	700		V/mV
Output Voltage Swing	V_O	$R_L \geq 2k\Omega$	± 12.5	± 13.5		± 12.5	± 13.5		V
Power Dissipation	P_D	No load	55	90		60	100		mW

ELECTRICAL CHARACTERISTICS

($V_S = \pm 15V$, $0^\circ C \leq T_A \leq +70^\circ C$, unless otherwise noted.)

PARAMETER	SYMBOL	CONDITIONS	MXL1001AC			MXL1001C			UNITS
			MIN	TYP	MAX	MIN	TYP	MAX	
Input Offset Voltage	V_{OS}	(Note 6)	20	60		30	110		μV
Average Temperature Coefficient of Input Offset Voltage	TCV_{OS}		0.2	0.6		0.3	1.0		$\mu V/^\circ C$
Input Offset Current	I_{OS}		0.5	3.5		0.6	5.3		nA
Input Bias Current	I_B		± 0.7	± 3.5		± 1.0	± 5.5		nA
Input Voltage Range	IVR		± 13	± 14		± 13	± 14		V
Common-Mode Rejection Ratio	CMRR	$V_{CM} = \pm 13V$	110	124		106	123		dB
Power-Supply Rejection Ratio	PSRR	$V_S = \pm 3V$ to $\pm 18V$	106	120		103	120		dB
Large-Signal Voltage Gain	A_{VO}	$R_L \geq 2k\Omega$, $V_O = \pm 10V$	350	750		250	750		V/mV
Output Voltage Swing	V_O	$R_L \geq 2k\Omega$	± 12.5	± 13.8		± 12.5	± 13.8		V
Power Dissipation	P_D	No load	50	85		55	90		mW

Note 6: MXL1001A grade offset voltage is measured one minute after application of power. For all other grades V_{OS} is measured 0.5 seconds after power on.

Precision Operational Amplifier

Applications Information

The MXL1001 series devices are pin-compatible with the OP-07, OP-05, 725, 108A or 101A amplifiers. The MXL1001 amplifiers can be used to upgrade older designs using these devices, with or without removal of external frequency compensation or nulling components. The MXL1001 can also be used in 741, LF156 or OP-15 applications provided the nulling circuitry is removed.

The MXL1001 is specified over a wide supply voltage range from $\pm 3V$ to $\pm 18V$. Operation with lower supplies is possible down to $\pm 1.2V$ (two NiCd batteries), however, at this level the device is stable only in closed-loop gains of +2 and above (or inverting gain of one or higher). Unless proper care is exercised, thermocouple effects caused by temperature gradients across dissimilar metals at the input terminal connections, can exceed the inherent offset-voltage drift of the amplifier. Air currents over the device leads should be minimized, package leads should be short, and the two input leads should be as close together as possible and maintained at the same temperature.

Offset-Voltage Adjustment

The input offset voltage of the MXL1001, and its temperature drift, are minimized by zener-zap trimming at the wafer level. If further nulling of V_{OS} is required, this can be performed using a $10k\Omega$ or $20k\Omega$ potentiometer with no degradation of V_{OS} drift with temperature. Trimming to a value other than zero creates a drift of $(V_{OS}/300)\mu V/^\circ C$; i.e., if V_{OS} is adjusted to $300\mu V$, the change in drift will be $1\mu V/^\circ C$. The adjustment range with a $10k\Omega$ or $20k\Omega$ potentiometer is approximately $\pm 2.5mV$. If less adjustment range is needed, the sensitivity and resolution of the offset nulling can be improved by using a potentiometer of lower ohmic value in conjunction with fixed resistors.

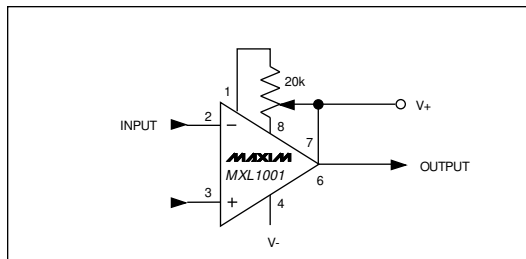
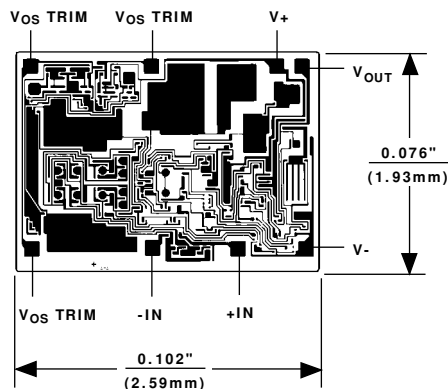

Figure 1. Optional Offset Nulling Circuit

Chip Topography



SUBSTRATE IS CONNECTED TO V-

Maxim cannot assume responsibility for use of any circuitry other than circuitry entirely embodied in a Maxim product. No circuit patent licenses are implied. Maxim reserves the right to change the circuitry and specifications without notice at any time.

4 Maxim Integrated Products, 120 San Gabriel Drive, Sunnyvale, CA 94086 (408) 737-7600