

AC/DC Drivers

AC/DC Controller IC for LED Lighting Included 650V MOSFET

BM520Q15F

● **General Description**

The AC/DC quasi-resonant controller type LED driver IC BM520Q15F can be applied to a non-isolated application, making the designs for various types of low power converter easy.

The low power consumption and high-speed start are achieved through the start-up circuit with 650V withstand voltage.

Due to the quasi-resonant mode, soft switching is achieved. The EMI is also improved by the alterable operating frequency. A power supply design with a high degree of freedom can also be achieved by the external current setting resistance.

A low-cost application can be achieved with the built-in MOSFET with 650V withstand voltage. It also makes the application design easy.

● **Features**

- Quasi-resonant Switching Mode
- Built-in 650V Starter Circuit
- Built-in 650V Switching MOSFET
- Maximum Frequency of 200kHz
- VCC pin: Under Voltage Protection
- VCC pin: Over Voltage Protection (latch)
- SOURCE pin: Leading-Edge-Blanking Function
- ZT pin: Trigger Mask Function
- ZT pin: Over Voltage Protection (latch)
- NTC pin: Temperature Detecting Protection (Automatic Recovery)

● **Package**

SOP8 5.00mm × 4.40mm pitch 1.27mm
(Typ) (Typ) (Typ)



● **Key Specifications**

- Operating Power Supply Voltage Range:
VCC 8.9V to 26.0V DRAIN: ~650V
- Operating Current: Normal Operation: 0.35mA (Typ)
- Operating Temperature Range: - 40°C. to +105°C
- MOSFET ON Resistance: 4.0Ω (Typ)

● **Application**

LED bulb, sealed-type LED lighting
Electrical machineries for LED lighting

● **Typical Application Circuit**

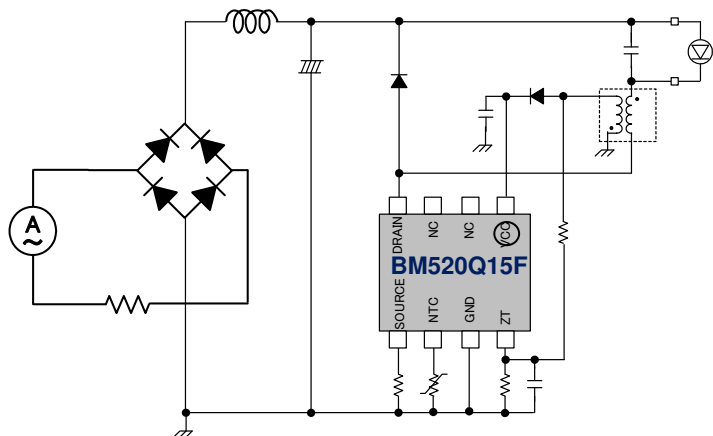

Figure 1. Application circuit

● Absolute Maximum Ratings (Ta=25°C)

Item	Symbol	Rating	Unit	Condition
Input Voltage Range 1	Vmax1	-0.3 to 30	V	VCC
Input Voltage Range 2	Vmax2	-0.3 to 6.5	V	SOURCE, NTC, ZT
Input Voltage Range 3	Vmax3	650	V	DRAIN
Drain Current Pulse	I _{DP}	2.60	A	P _w =10us, Duty cycle=1%
Maximum Power Dissipation	P _d	563 (Note1)	mW	
Operating Temperature Range	T _{opr}	-40 to +105	°C	
Maximum Junction Temperature	T _{jmax}	150	°C	
Storage Temperature Range	T _{str}	-55 to +150	°C	

(Note1) When mounted (on 70 mm × 70 mm, 1.6 mm thick, glass epoxy on single-layer substrate). Derate by 4.563 mW/°C above Ta = 25°C.

● Recommended Operating Conditions (Ta=25°C)

Parameter	Symbol	Rating	Unit	Condition
Input Voltage Range 1	VCC	8.9 to 26.0	V	VCC voltage
Input Voltage Range 2	V _{DRAIN}	0 to 650	V	DRAIN voltage

● Electrical Characteristics (Ta=25°C)

MOSFET (Unless otherwise specified Ta = 25°C, VCC = 15V)

Parameter	Symbol	Specification			Unit	Condition
		Min	Typ	Max		
Drain-Source Breakdown Voltage	V _{(BR)DDS}	650	-	-	V	ID=1mA / VGS=0V
Drain Leakage Current	I _{DSS}	-	-	100	uA	VDS=650V / VGS=0V
ON Resistance	R _{DS(ON)}	-	4	5.5	Ω	ID=0.25A / VGS=10V

●Electrical Characteristics

IC (Unless otherwise specified, Ta = 25°C, VCC = 15 V)

Parameter	Symbol	Specification			Unit	Condition
		Min	Typ	Max		
[Circuit current]						
Circuit Current (ON)1	I _{ON1}	120	350	700	μA	NTC=2.0V(PULSE operating) BM520Q15F
Circuit Current (ON)2	I _{ON2}	-	220	400	μA	NTC=0V(PULSE OFF)
[VH pin start up circuit]						
VH Starting Current 1	I _{START1}	0.20	0.55	0.90	mA	VCC= 0V
VH Starting Current 2	I _{START2}	1	3	6	mA	VCC=10V
VH OFF Current	I _{START3}	-	10	20	uA	VCC UVLO released VH pin sink current
VH Starting Current Switching Voltage	V _{SC}	0.3	0.7	1.6	V	VCC pin
[VCC pin protection]						
VCC UVLO Voltage 1	V _{UVLO1}	12.5	13.5	14.5	V	VCC rising up
VCC UVLO Voltage 2	V _{UVLO2}	7.5	8.2	8.9	V	VCC falling down
VCC UVLO Hysteresis	V _{UVLO3}	-	5.3	-	V	V _{UVLO3} = V _{UVLO1} - V _{UVLO2}
VCC OVP Trigger Voltage	V _{OVP1}	25.0	27.5	30.0	V	VCC rising up
VCC OVP Release Voltage	V _{OVP2}	21.0	23.5	26.0	V	VCC falling down
Latch Released VCC Voltage	V _{LATCH2}	-	V _{UVLO2} -0.5	-	V	VCC falling down
VCC Recharge Start Voltage	V _{CHG1}	7.7	8.7	9.7	V	VCC falling down
VCC Recharge End Voltage	V _{CHG2}	12	13	14	V	VCC rising up
Latch Mask Time	T _{LATCH}	60	100	140	us	
[DC/DC comparator (turn-on)]						
ZT Comparator Voltage 1	V _{ZT1}	40	100	160	mV	ZT falling down
ZT Comparator Voltage 2	V _{ZT2}	120	200	280	mV	ZT rising up
ZT Comparator Hysteresis	V _{ZTHYS}	-	100	-	mV	V _{ZTHYS} = V _{ZT1} - V _{ZT2}
ZT Trigger Mask Time	T _{ZTMASK}	-	0.8	-	us	VZT H->L, for preventing from noise
ZT Trigger Timeout	T _{ZTOUT}	10	15	20	us	
[DC/DC comparator (turn-off)]						
Current Trigger Voltage	V _{CS}	0.57	0.6	0.63	V	No AC compensation
Maximum Frequency	F _{SW}	180	200	220	KHz	
Leading Edge Blank Time	T _{LEB}	-	0.2	-	us	
Maximum ON Time	T _{max}	30	39	50.7	us	
[DC/DC protection]						
ZT OVP Voltage	V _{ZTL}	3.250	3.500	3.750	V	
[NTC pin protection]						
NTC Pin Source current	I _{NTC}	45	50	55	uA	NTC voltage=1.0V
NTC Trigger Voltage	V _{NTC}	0.06	0.12	0.18	V	NTC voltage falling down
NTC Hysteresis	V _{NTCHYS}	0.04	0.08	0.12	V	NTC voltage rising up

● Pin Description

Table 1. I/O PIN functions

NO.	Pin Name	I/O	Function	ESD protection	
				VCC	GND
1	VCC	I/O	Power Supply pin	-	○
2	N.C.	-	Non Connection	-	-
3	N.C.	-	Non Connection	-	-
4	DRAIN	I/O	MOSFET DRAIN pin	-	○
5	SOURCE	I	MOSFET DRAIN pin Inductor Current Sensing pin	-	○
6	NTC	I/O	NTC Detect Input pin	-	○
7	GND	I/O	GND pin, Input pin for Feedback Signal	○	-
8	ZT	I	Zero Current Detecting pin	-	○

● I/O Equivalent Circuit Diagram

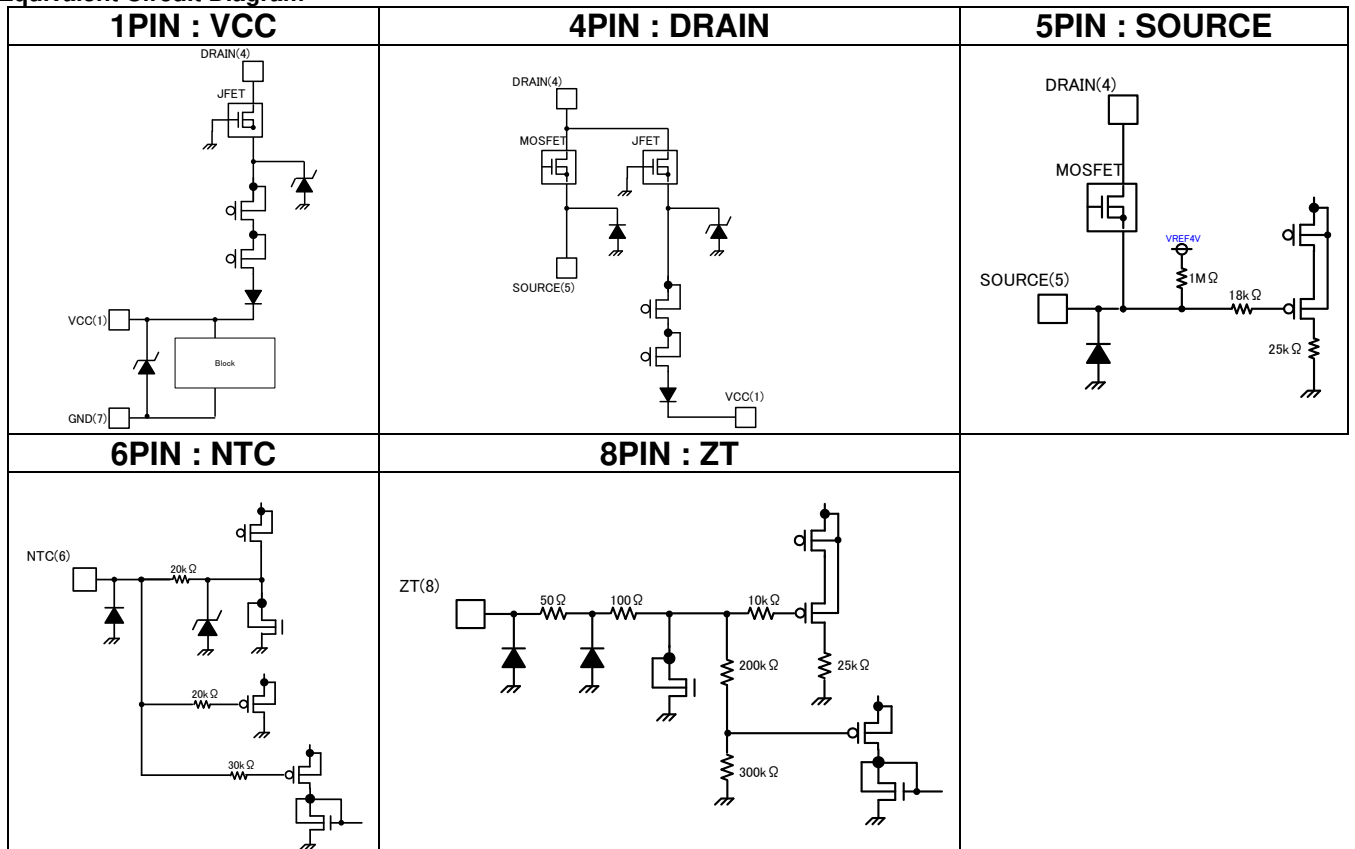

Figure 2. I/O equivalent circuit diagram

●Block Diagram

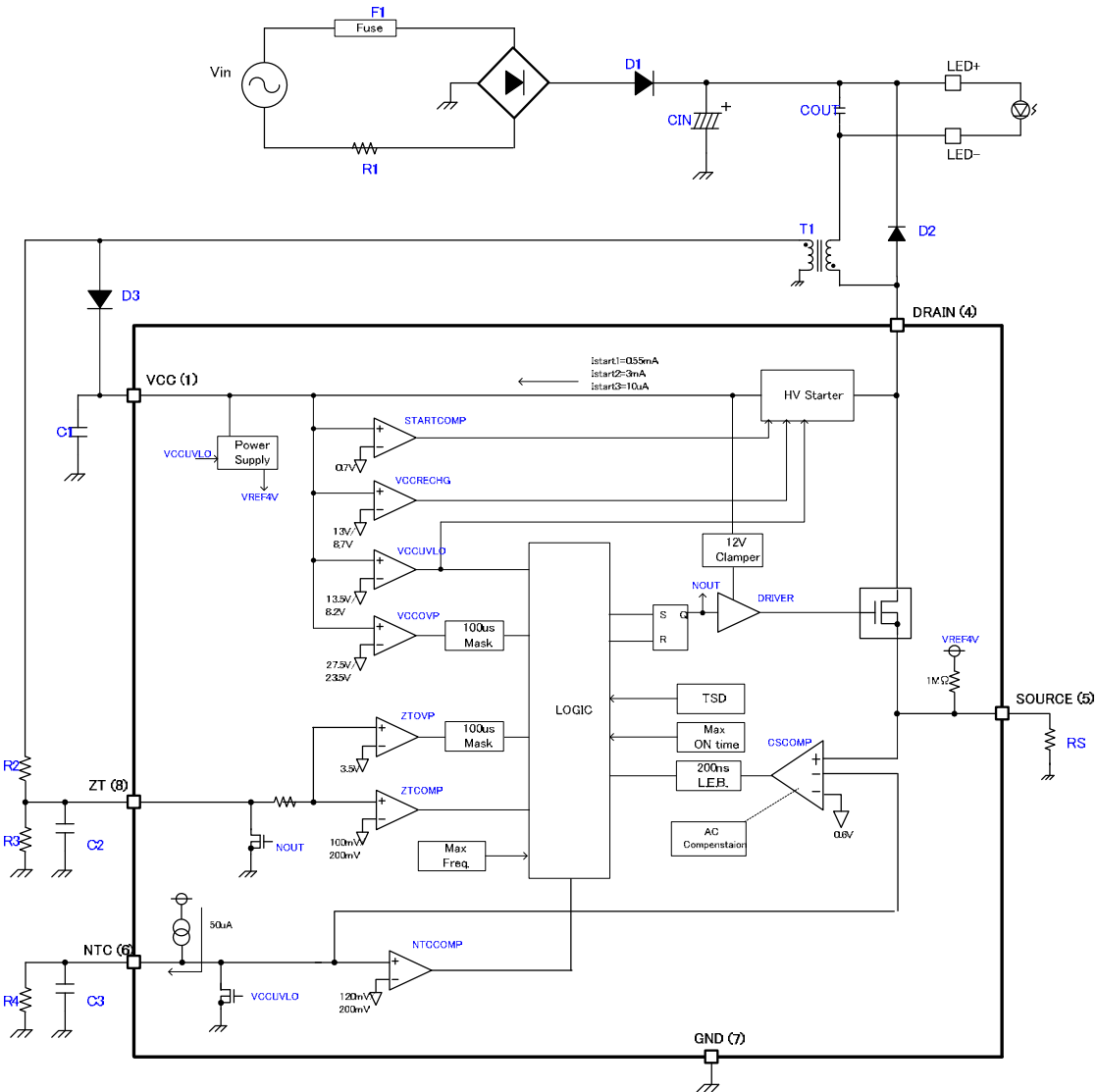

Figure 3. Block diagram

●External Dimensions

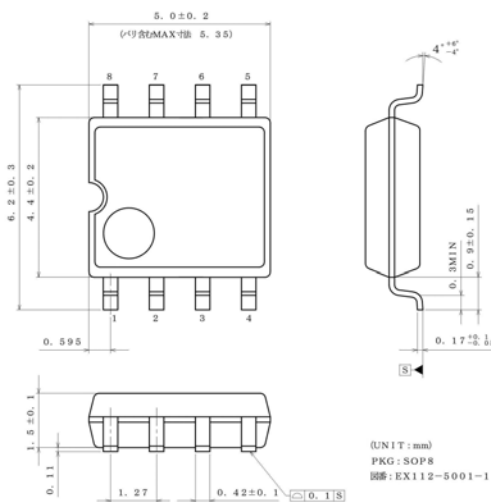

Figure 4. SOP8 package external dimensions

●Block Descriptions

(1) Start-up circuit (DRAIN: 4pin, VCC:1pin)

(1-1)Block Descriptions

A bootstrap circuit with 650V withstand voltage is built in this IC. Thus, low-power standby and high-speed start can be achieved. After the IC was booted up, the power consumption becomes only the idling current (typ=10uA). The reference value of the start-up time is showed in Figure 7. When C_{VCC}=10uF, the start-up time can be less than 0.1s.

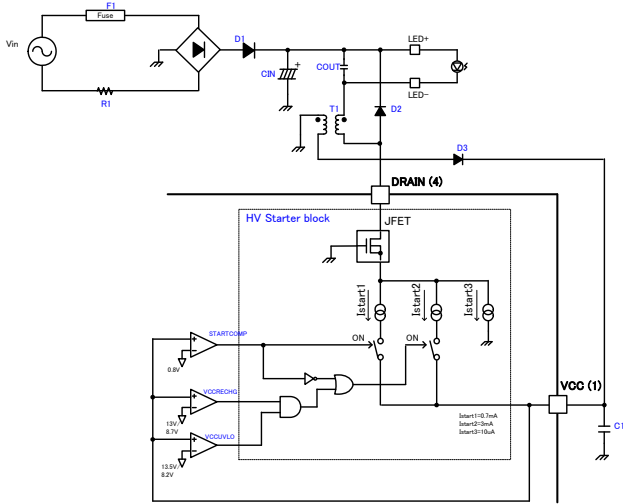

Figure 5. Start-up circuit block diagram

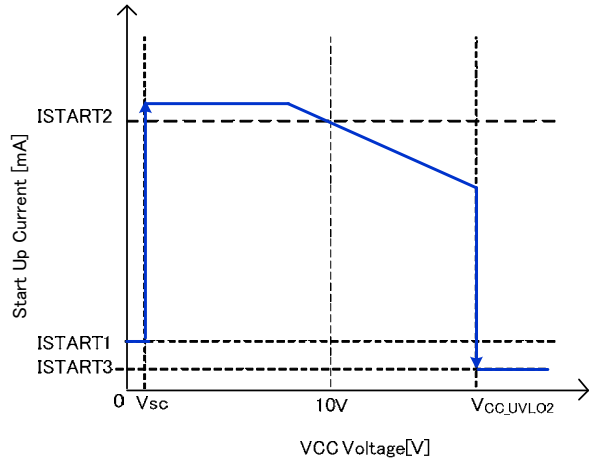

Figure 6. Start-up current—VCC voltage curve

The start-up current means the current from the DRAIN pin.
 ex: When Vac=100V, the power consumption of bootstrap circuit is
 $P_{VH} = 100V \cdot \sqrt{2} \cdot 10\mu A = 1.41mW$
 ex: When Vac=240V, the power consumption of bootstrap circuit is
 $P_{VH} = 240V \cdot \sqrt{2} \cdot 10\mu A = 3.38mW$

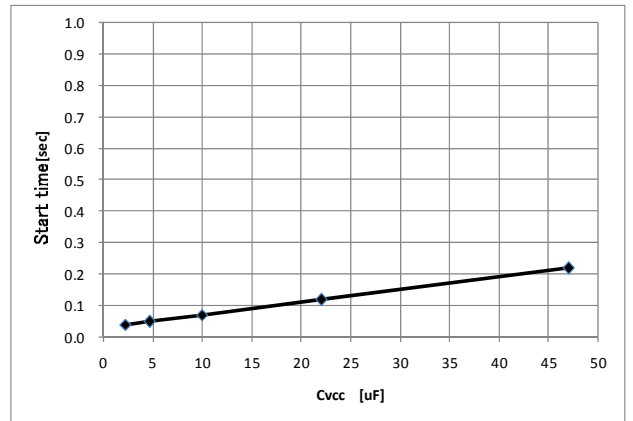

Figure 7. Start-up time—VCC capacitance characteristics

(1-2)Start sequences 1 (VCC supply with auxiliary winding)

The time chart of the start sequences are showed in Figure 9. The DC/DC circuit which reduces the power consumption of the IC can be composed by using the auxiliary winding of the transformer.

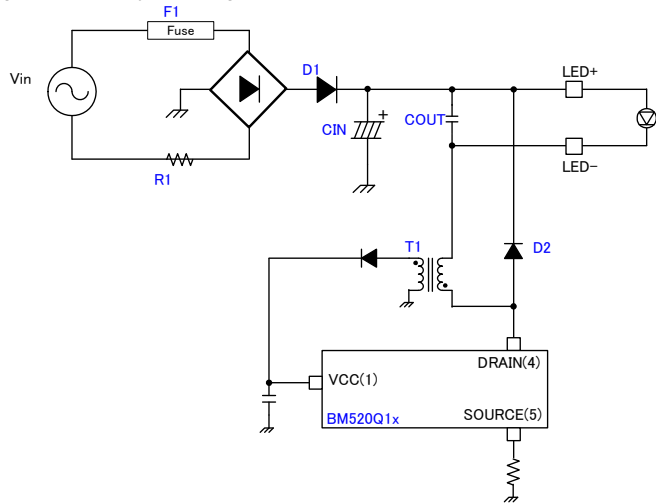

Figure 8. Schematic of the DC/DC Part while Supplying with the Auxiliary Winding

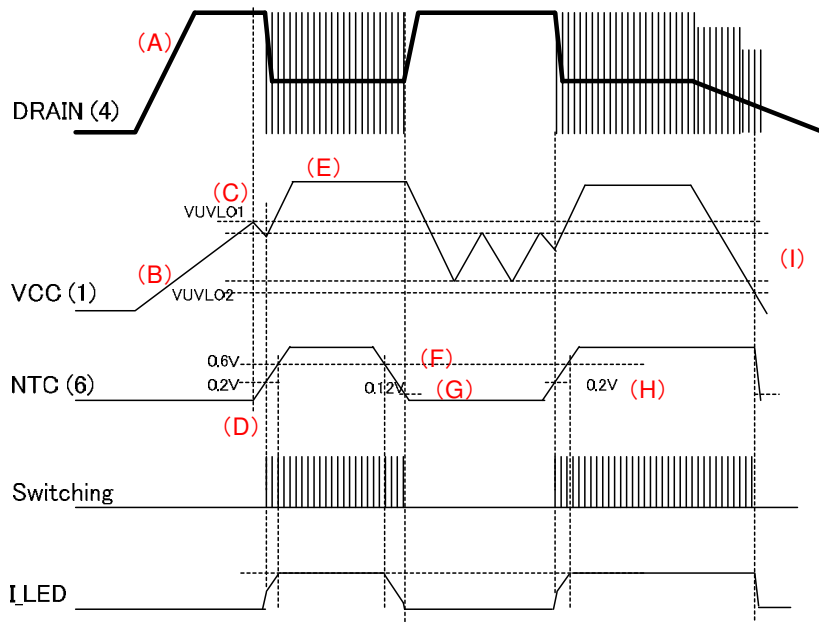

Figure 9. ON/OFF Sequences (supplying VCC with auxiliary winding)

- A: Input voltage V_H is applied. (Though the LED and the transformer, a high voltage is applied to DRAIN pin from V_H .)
- B: The capacitor connected to the VCC pin is charged by the start-up current from the DRAIN pin.
- C: The IC starts operating when $V_{CC} > V_{UVLO1}$
- D: The soft start is achieved by the voltage rise of the NTC pin. (The switching starts when $V_{NTC} > 0.2V$)
- E: The current is supplied to VCC pin from the auxiliary winding by the switching operation.
- ※The power is supplied by the auxiliary winding, and the VCC voltage is determined by the specification of transformer.
- F: While the voltage of NTC pin is falling down, the LED current decreases from $V_{NTC} < 0.6V$.
- G: The switching operation stops when $V_{NTC} < 0.1V$. The current supply to VCC pin disappears, the recharge operation of VCC pin is repeated.
- H: The switching operation restarts when $V_{NTC} > 0.2V$. The VCC is supplied by the auxiliary winding.
- I: When the power supply turns OFF, VCC voltage falls down due to descend of the voltage of DRAIN pin. The IC turns OFF when the V_{UVLO2} is triggered.

(1-3)Start sequences 2 (no VCC supply with auxiliary winding)

While IC operates after VCCUVLO is released, VCC pin operates by the charge/discharge to the external capacitor. The VCC is supplied with the start-up circuit. This circuit can be composed without the auxiliary winding of the transistor. Figure 10 shows the schematic of the DC/DC part.

It is necessary to pay attention to the heat which is caused by the power consumption of the JFET of the start-up circuit, while there is no VCC supply to the auxiliary winding of the transformer.

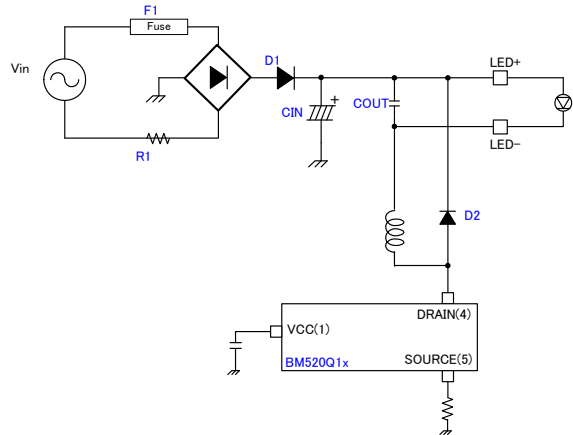

Figure 10. Schematic of the DC/DC Part without Power Supply by Auxiliary Winding

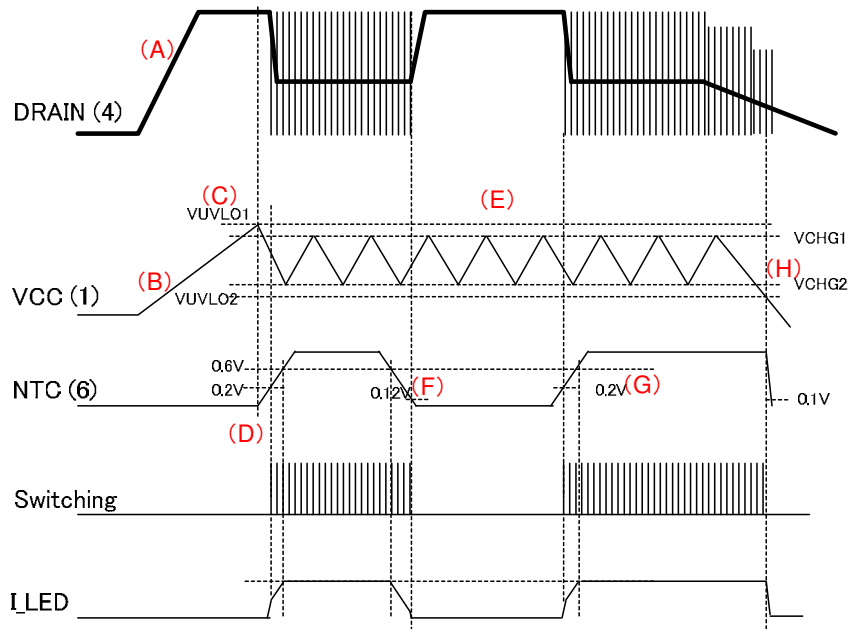

Figure 11. ON/OFF Sequences (no VCC supply with auxiliary winding)

- A: Input voltage V_H is applied. (Though the LED and the transformer, a high voltage is applied to DRAIN pin from V_H .)
- B: The capacitor connected to the VCC pin is charged by the start-up current from the DRAIN pin.
- C: The IC starts operating when $V_{CC} > V_{UVLO1}$
- D: The soft start is achieved by the voltage rise of the NTC pin. (The switching starts when $V_{NTC} > 0.2V$)
- E: The VCC repeats charge/recharge operations between the recharge trigger voltage V_{CHG1} and V_{CHG2} .
- F: The switching operation stops when $V_{NTC} < 0.12V$.
- G: The switching operation restarts when $V_{NTC} > 0.2V$.
- H: When the power supply turns OFF, VCC voltage falls down due to descend of DRAIN pin voltage. The IC turns OFF when the V_{UVLO2} is triggered.

(2) VCC pin protection function

The VCC under voltage protection function VCC UVLO (Under Voltage Lock Out), over voltage protection function VCC OVP (Over Voltage Protection), and a VCC recharge function which operates when a voltage drop occurs at VCC pin are all built in this IC. The VCC UVLO and VCC OVP functions are used for preventing the destructions of the switching MOSFET which occurs when the VCC voltage is too high or too low.

Due to the VCC charge function, the VCC pin is charged from high voltage lines by the start circuit when the VCC voltage drops, and the secondary output voltage is stabilized.

(2-1) VCC UVLO / VCC OVP function

VCC UVLO and VCC OVP are auto recovery comparators which have voltage hysteresis.

VCC OVP has a built-in mask time T_{LATCH} (Typ=100us).

The detection is executed when the VCC voltage is over V_{OVP} (typ=27.5V), and this state lasts T_{LATCH} (typ=100us).

By this function, the surge which occurs at VCC pin can be masked.

(2-2) VCC charge function

When the VCC pin voltage is over V_{UVLO1} , the IC starts up. In this case, if the VCC pin voltage drops below V_{CHG1} , VCC charge function operates. At this time, the VCC pin is charged from the DRAIN pin through the bootstrap circuit. Due to this operation, the failure of start-up can be prevented.

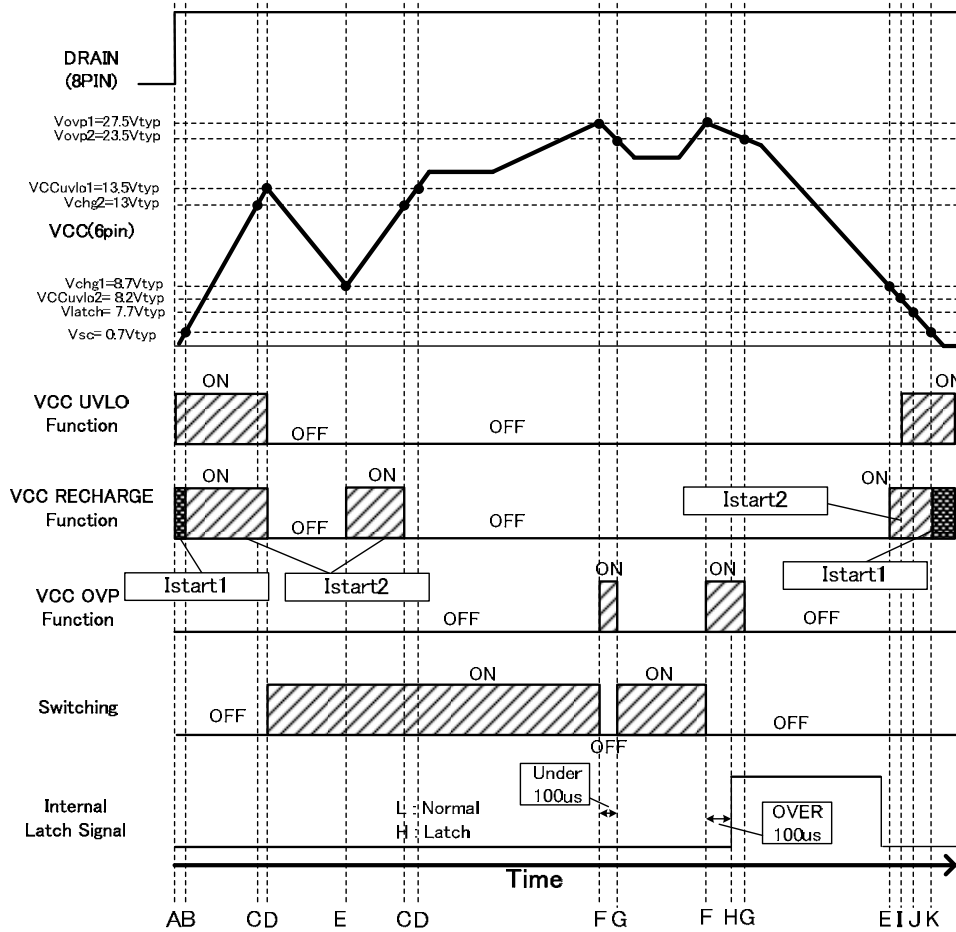

Figure 12. VCC UVLO/ VCC OVP / VCC charge function timing chart

- A: DRAIN pin voltage is applied, VCC voltage rises by the charging current Istart1 (550uA typ).
- B: VCC voltage > V_{SC} , the charging current to VCC changes from Istart1 (550uA typ) to Istart2 (3mA typ)
- C: VCC voltage > V_{CHG2} , though VCC charge function reacts, due to VCC UVLO is detected, the charge continues.
- D: VCC voltage > V_{UVLO1} , the VCC UVLO is released and DC/DC operation starts, the charge to VCC stops.
- E: VCC voltage > V_{CHG1} , the charge to VCC restarts.
- F: VCC voltage > V_{OVP1} , VCC OVP is detected.
- G: VCC voltage > V_{OVP2} , if VCC voltage drops below V_{OVP2} in 100us, VCC OVP is released and the latch will not be activated.
- H: V_{OVP2} < VCC voltage < V_{OVP1} , if this state is kept longer than 100us, the switching stops by latch.
- I: VCC voltage < V_{UVLO1} , VCC UVLO is detected.
- J: VCC voltage < V_{LATCH} , the latch state is released.
- K: VCC voltage < V_{SC} , the charging current to VCC changes from Istart2 (3mA typ) ⇒ Istart1 (550uA typ)

(3) LED peak current sensing

The peak current sensing is proceeded in every switching cycle. The switching turns OFF if the voltage of SOURCE pin exceeds some certain value. An AC compensation function is built in this IC. It is a function which increases the LED peak current sensing level with the increment of time. This operation is showed in Figure 13,14.

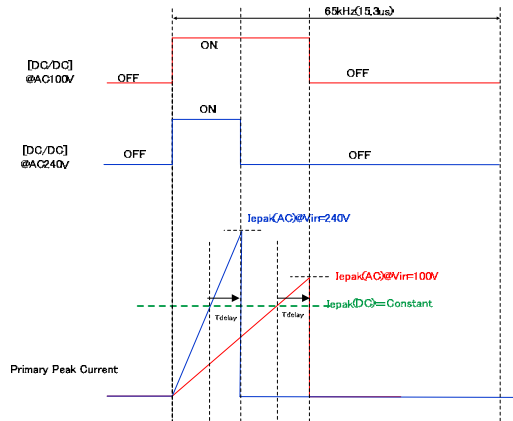

Figure 13. Peak current sensing without AC compensation

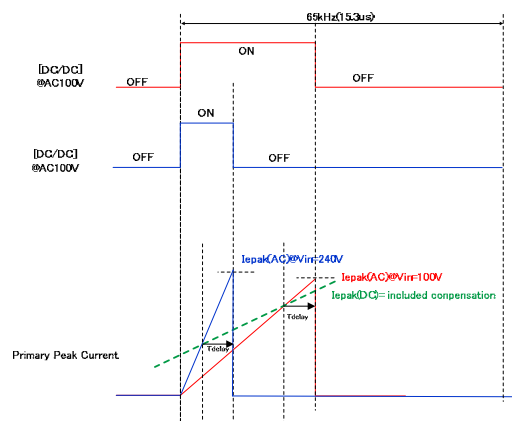

Figure 14. Peak current sensing with AC compensation

(4) L.E.B blanking period

When the MOSFET driver is turned ON, the capacitive components generates surge current and drive current. In this case, if the SOURCE pin voltage rises temporarily, false detections may occur in the over current limiter circuit. A L.E.B function (Leading Edge Blanking function) which masks the SOURCE voltage during the 200nsec after the OUT pin switches form L to H is built in to prevent false detections

(5) SOURCE pin open protection

The IC may be damaged by overheating when the SOURCE pin (pin 5) becomes open. To prevent this from happening, an open protection circuit is built in this IC. (Automatic recovery protection)

(6) NTC pin temperature detecting protection

Voltage is generated on the thermistor by a 50uA source current from the NTC pin. When NTC pin voltage is lower than 0.67V, the LED peak current reduces gradually. When this voltage becomes lower than 0.12V, the switching operation stops. When NTC voltage rises up again higher than 0.2V, the switching operation restarts.

●Operation mode of protection circuit

Operation mode of protection functions are shown in Table 2.

Table 2. Operation mode of protection circuit

Abnormal state detection		Detect	Release	Protection operations
VCC	UVLO	$\leq 8.2V$	$\geq 13.5V$	Automatic recovery
	OVP	$\geq 27.5V$	Before latch: $\leq 23.5V$ Latched: $VCC \leq 7.7V$	100us timer latch
TSD		$\geq 175^{\circ}C$	Before latch: $\leq 155^{\circ}C$ Latched: $VCC \leq 7.7V$	100us timer latch
ZT	OVP	$\geq 3.50V$	Before latch: $\leq 3.33V$ Latched: $VCC \leq 7.7V$	100us timer latch
NTC	LED TEMP	$\leq 0.12V$	$\geq 0.2V$	Switching OFF

●Sequences

The sequences diagram of all states of this IC is shown in Figure 15.

In all states, when $VCC < 8.2V$, the states change to OFF mode.

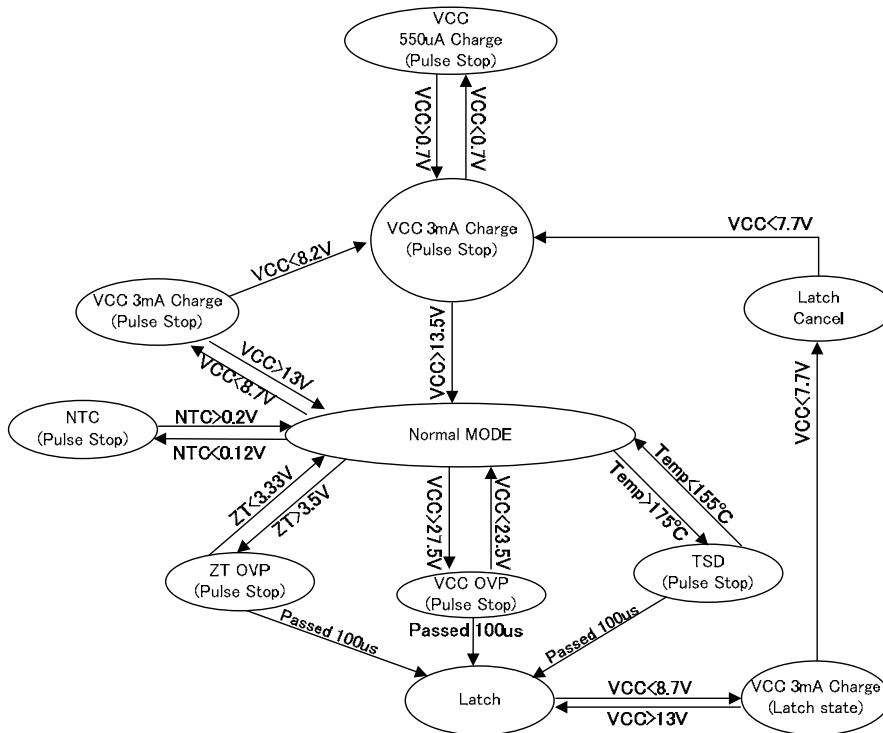

Figure 15. Transition diagram of all states

●Power Dissipation

According to the thermal design, please observe the conditions below when use this IC.

1. The ambient temperature T_a must be 105°C or less.
2. The consumption of the IC must be within the allowable power dissipation P_d .

The thermal dissipation characteristics are as follows.
 (PCB: 70 mm × 70mm × 1.6 mm, mounted on glass epoxy substrate)

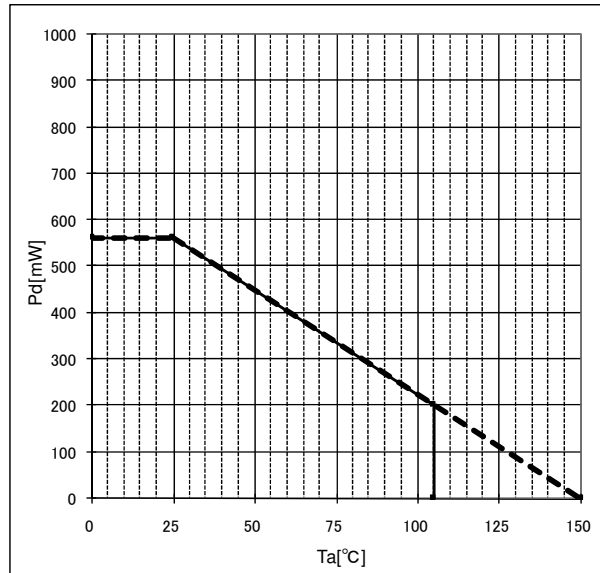

Figure 16. Power Dissipation characteristics

Operational Notes

1. Reverse Connection of Power Supply

Connecting the power supply in reverse polarity can damage the IC. Take precautions against reverse polarity when connecting the power supply, such as mounting an external diode between the power supply and the IC's power supply terminals.

2. Power Supply Lines

Design the PCB layout pattern to provide low impedance supply lines. Separate the ground and supply lines of the digital and analog blocks to prevent noise in the ground and supply lines of the digital block from affecting the analog block. Furthermore, connect a capacitor to ground at all power supply pins. Consider the effect of temperature and aging on the capacitance value when using electrolytic capacitors.

3. Ground Voltage

Ensure that no pins are at a voltage below that of the ground pin at any time, even during transient condition.

4. Ground Wiring Pattern

When using both small-signal and large-current ground traces, the two ground traces should be routed separately but connected to a single ground at the reference point of the application board to avoid fluctuations in the small-signal ground caused by large currents. Also ensure that the ground traces of external components do not cause variations on the ground voltage. The ground lines must be as short and thick as possible to reduce line impedance.

5. Thermal Consideration

Should by any chance the power dissipation rating be exceeded the rise in temperature of the chip may result in deterioration of the properties of the chip. The absolute maximum rating of the Pd stated in this specification is when the IC is mounted on a 70mm x 70mm x 1.6mm glass epoxy board. In case of exceeding this absolute maximum rating, increase the board size and copper area to prevent exceeding the Pd rating.

6. Recommended Operating Conditions

These conditions represent a range within which the expected characteristics of the IC can be approximately obtained. The electrical characteristics are guaranteed under the conditions of each parameter.

7. Inrush Current

When power is first supplied to the IC, it is possible that the internal logic may be unstable and inrush current may flow instantaneously due to the internal powering sequence and delays, especially if the IC has more than one power supply. Therefore, give special consideration to power coupling capacitance, power wiring, width of ground wiring, and routing of connections.

8. Operation Under Strong Electromagnetic Field

Operating the IC in the presence of a strong electromagnetic field may cause the IC to malfunction.

9. Testing on Application Boards

When testing the IC on an application board, connecting a capacitor directly to a low-impedance output pin may subject the IC to stress. Always discharge capacitors completely after each process or step. The IC's power supply should always be turned off completely before connecting or removing it from the test setup during the inspection process. To prevent damage from static discharge, ground the IC during assembly and use similar precautions during transport and storage.

10. Inter-pin Short and Mounting Errors

Ensure that the direction and position are correct when mounting the IC on the PCB. Incorrect mounting may result in damaging the IC. Avoid nearby pins being shorted to each other especially to ground, power supply and output pin. Inter-pin shorts could be due to many reasons such as metal particles, water droplets (in very humid environment) and unintentional solder bridge deposited in between pins during assembly to name a few.

Operational Notes – continued

11. Unused Input Terminals

Input terminals of an IC are often connected to the gate of a MOS transistor. The gate has extremely high impedance and extremely low capacitance. If left unconnected, the electric field from the outside can easily charge it. The small charge acquired in this way is enough to produce a significant effect on the conduction through the transistor and cause unexpected operation of the IC. So unless otherwise specified, unused input terminals should be connected to the power supply or ground line.

12. Regarding the Input Pin of the IC

This monolithic IC contains P+ isolation and P substrate layers between adjacent elements in order to keep them isolated. P-N junctions are formed at the intersection of the P layers with the N layers of other elements, creating a parasitic diode or transistor. For example (refer to figure below):

When $GND > Pin A$ and $GND > Pin B$, the P-N junction operates as a parasitic diode.
 When $GND > Pin B$, the P-N junction operates as a parasitic transistor.

Parasitic diodes inevitably occur in the structure of the IC. The operation of parasitic diodes can result in mutual interference among circuits, operational faults, or physical damage. Therefore, conditions that cause these diodes to operate, such as applying a voltage lower than the GND voltage to an input pin (and thus to the P substrate) should be avoided.

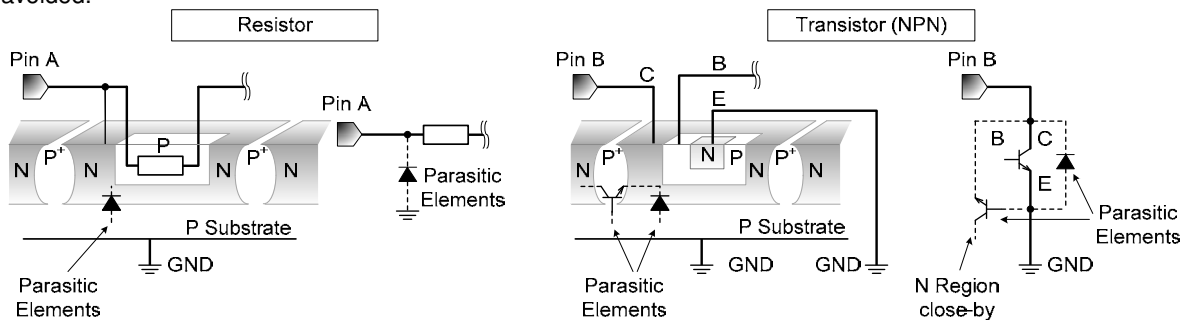

Example of monolithic IC structure

13. Ceramic Capacitor

When using a ceramic capacitor, determine the dielectric constant considering the change of capacitance with temperature and the decrease in nominal capacitance due to DC bias and others.

14. Area of Safe Operation (ASO)

Operate the IC such that the output voltage, output current, and power dissipation are all within the Area of Safe Operation (ASO).

15. Thermal Shutdown Circuit(TSD)

This IC has a built-in thermal shutdown circuit that prevents heat damage to the IC. Normal operation should always be within the IC's power dissipation rating. If however the rating is exceeded for a continued period, the junction temperature (T_j) will rise which will activate the TSD circuit that will turn OFF all output pins. When the T_j falls below the TSD threshold, the circuits are automatically restored to normal operation.

Note that the TSD circuit operates in a situation that exceeds the absolute maximum ratings and therefore, under no circumstances, should the TSD circuit be used in a set design or for any purpose other than protecting the IC from heat damage.

16. Over Current Protection Circuit (OCP)

This IC incorporates an integrated overcurrent protection circuit that is activated when the load is shorted. This protection circuit is effective in preventing damage due to sudden and unexpected incidents. However, the IC should not be used in applications characterized by continuous operation or transitioning of the protection circuit.

●Physical Dimension, Tape and Reel Information

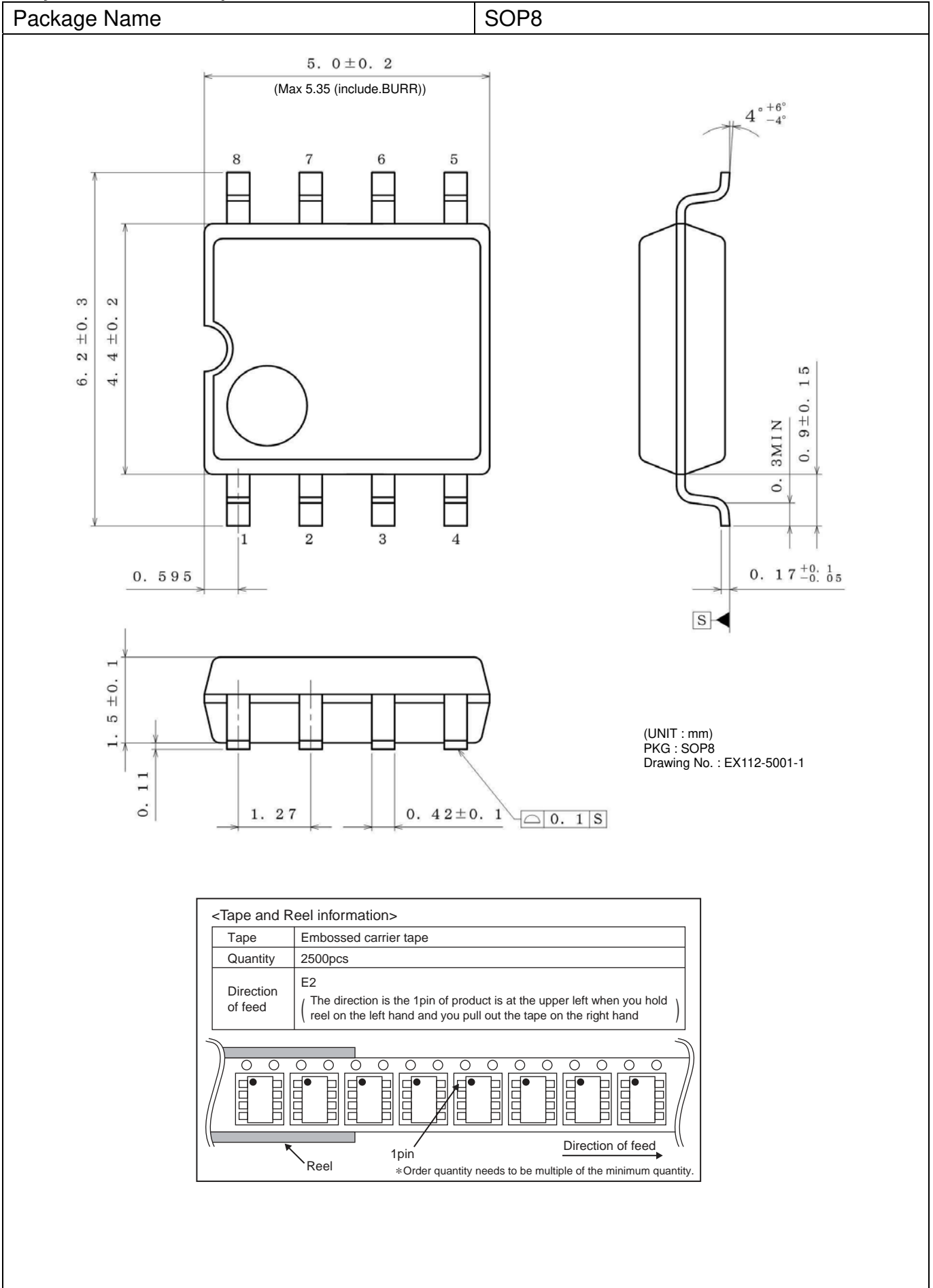

● Ordering Information

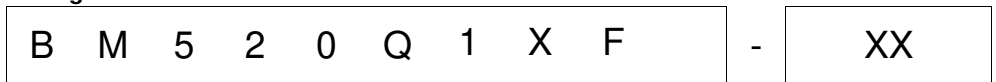

Product name

Package
F : SOP8

Packaging and forming specification

XX: Please confirm the formal name with our salesmen.

● Marking Diagram

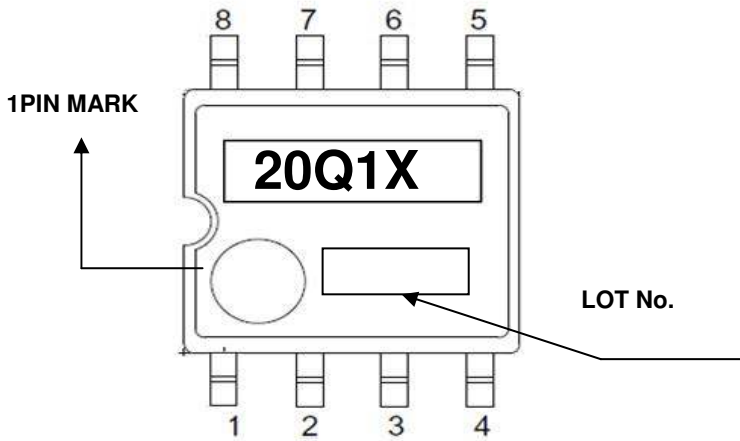

Notice

Precaution on using ROHM Products

1. Our Products are designed and manufactured for application in ordinary electronic equipments (such as AV equipment, OA equipment, telecommunication equipment, home electronic appliances, amusement equipment, etc.). If you intend to use our Products in devices requiring extremely high reliability (such as medical equipment, transport equipment, traffic equipment, aircraft/spacecraft, nuclear power controllers, fuel controllers, car equipment including car accessories, safety devices, etc.) and whose malfunction or failure may cause loss of human life, bodily injury or serious damage to property ("Specific Applications"), please consult with the ROHM sales representative in advance. Unless otherwise agreed in writing by ROHM in advance, ROHM shall not be in any way responsible or liable for any damages, expenses or losses incurred by you or third parties arising from the use of any ROHM's Products for Specific Applications.
2. ROHM designs and manufactures its Products subject to strict quality control system. However, semiconductor products can fail or malfunction at a certain rate. Please be sure to implement, at your own responsibilities, adequate safety measures including but not limited to fail-safe design against the physical injury, damage to any property, which a failure or malfunction of our Products may cause. The following are examples of safety measures:
 - [a] Installation of protection circuits or other protective devices to improve system safety
 - [b] Installation of redundant circuits to reduce the impact of single or multiple circuit failure
3. Our Products are designed and manufactured for use under standard conditions and not under any special or extraordinary environments or conditions, as exemplified below. Accordingly, ROHM shall not be in any way responsible or liable for any damages, expenses or losses arising from the use of any ROHM's Products under any special or extraordinary environments or conditions. If you intend to use our Products under any special or extraordinary environments or conditions (as exemplified below), your independent verification and confirmation of product performance, reliability, etc. prior to use, must be necessary:
 - [a] Use of our Products in any types of liquid, including water, oils, chemicals, and organic solvents
 - [b] Use of our Products outdoors or in places where the Products are exposed to direct sunlight or dust
 - [c] Use of our Products in places where the Products are exposed to sea wind or corrosive gases, including Cl₂, H₂S, NH₃, SO₂, and NO₂
 - [d] Use of our Products in places where the Products are exposed to static electricity or electromagnetic waves
 - [e] Use of our Products in proximity to heat-producing components, plastic cords, or other flammable items
 - [f] Sealing or coating our Products with resin or other coating materials
 - [g] Use of our Products without cleaning residue of flux (even if you use no-clean type fluxes, cleaning residue of flux is recommended); or Washing our Products by using water or water-soluble cleaning agents for cleaning residue after soldering
 - [h] Use of the Products in places subject to dew condensation
4. The Products are not subject to radiation-proof design.
5. Please verify and confirm characteristics of the final or mounted products in using the Products.
6. In particular, if a transient load (a large amount of load applied in a short period of time, such as pulse. is applied, confirmation of performance characteristics after on-board mounting is strongly recommended. Avoid applying power exceeding normal rated power; exceeding the power rating under steady-state loading condition may negatively affect product performance and reliability.
7. De-rate Power Dissipation (Pd) depending on Ambient temperature (Ta). When used in sealed area, confirm the actual ambient temperature.
8. Confirm that operation temperature is within the specified range described in the product specification.
9. ROHM shall not be in any way responsible or liable for failure induced under deviant condition from what is defined in this document.

Precaution for Mounting / Circuit board design

1. When a highly active halogenous (chlorine, bromine, etc.) flux is used, the residue of flux may negatively affect product performance and reliability.
2. In principle, the reflow soldering method must be used; if flow soldering method is preferred, please consult with the ROHM representative in advance.

For details, please refer to ROHM Mounting specification

Precautions Regarding Application Examples and External Circuits

1. If change is made to the constant of an external circuit, please allow a sufficient margin considering variations of the characteristics of the Products and external components, including transient characteristics, as well as static characteristics.
2. You agree that application notes, reference designs, and associated data and information contained in this document are presented only as guidance for Products use. Therefore, in case you use such information, you are solely responsible for it and you must exercise your own independent verification and judgment in the use of such information contained in this document. ROHM shall not be in any way responsible or liable for any damages, expenses or losses incurred by you or third parties arising from the use of such information.

Precaution for Electrostatic

This Product is electrostatic sensitive product, which may be damaged due to electrostatic discharge. Please take proper caution in your manufacturing process and storage so that voltage exceeding the Products maximum rating will not be applied to Products. Please take special care under dry condition (e.g. Grounding of human body / equipment / solder iron, isolation from charged objects, setting of Ionizer, friction prevention and temperature / humidity control).

Precaution for Storage / Transportation

1. Product performance and soldered connections may deteriorate if the Products are stored in the places where:
 - [a] the Products are exposed to sea winds or corrosive gases, including Cl₂, H₂S, NH₃, SO₂, and NO₂
 - [b] the temperature or humidity exceeds those recommended by ROHM
 - [c] the Products are exposed to direct sunshine or condensation
 - [d] the Products are exposed to high Electrostatic
2. Even under ROHM recommended storage condition, solderability of products out of recommended storage time period may be degraded. It is strongly recommended to confirm solderability before using Products of which storage time is exceeding the recommended storage time period.
3. Store / transport cartons in the correct direction, which is indicated on a carton with a symbol. Otherwise bent leads may occur due to excessive stress applied when dropping of a carton.
4. Use Products within the specified time after opening a humidity barrier bag. Baking is required before using Products of which storage time is exceeding the recommended storage time period.

Precaution for Product Label

QR code printed on ROHM Products label is for ROHM's internal use only.

Precaution for Disposition

When disposing Products please dispose them properly using an authorized industry waste company.

Precaution for Foreign Exchange and Foreign Trade act

Since our Products might fall under controlled goods prescribed by the applicable foreign exchange and foreign trade act, please consult with ROHM representative in case of export.

Precaution Regarding Intellectual Property Rights

1. All information and data including but not limited to application example contained in this document is for reference only. ROHM does not warrant that foregoing information or data will not infringe any intellectual property rights or any other rights of any third party regarding such information or data. ROHM shall not be in any way responsible or liable for infringement of any intellectual property rights or other damages arising from use of such information or data.:
2. No license, expressly or implied, is granted hereby under any intellectual property rights or other rights of ROHM or any third parties with respect to the information contained in this document.

Other Precaution

1. This document may not be reprinted or reproduced, in whole or in part, without prior written consent of ROHM.
2. The Products may not be disassembled, converted, modified, reproduced or otherwise changed without prior written consent of ROHM.
3. In no event shall you use in any way whatsoever the Products and the related technical information contained in the Products or this document for any military purposes, including but not limited to, the development of mass-destruction weapons.
4. The proper names of companies or products described in this document are trademarks or registered trademarks of ROHM, its affiliated companies or third parties.

General Precaution

1. Before you use our Products, you are requested to carefully read this document and fully understand its contents. ROHM shall not be in any way responsible or liable for failure, malfunction or accident arising from the use of any ROHM's Products against warning, caution or note contained in this document.
2. All information contained in this document is current as of the issuing date and subject to change without any prior notice. Before purchasing or using ROHM's Products, please confirm the latest information with a ROHM sales representative.
3. The information contained in this document is provided on an "as is" basis and ROHM does not warrant that all information contained in this document is accurate and/or error-free. ROHM shall not be in any way responsible or liable for any damages, expenses or losses incurred by you or third parties resulting from inaccuracy or errors of or concerning such information.